

PowerSurvivor[™] 40E Endurance Series 12-Volt & 24 Volt Watermakers



OWNER`S MANUAL

Thank you...

for purchasing a Katadyn *PowerSurvivor 40E* watermaker. It was built to rigorous specifications and designed to produce potable freshwater from clean seawater using minimal power. It is simple to install and operate and, with reasonable care and maintenance, can be expected to provide years of useful service.

Please...

before installing or operating your watermaker, take the short time needed to read this *User's Manual* in its entirety. That small investment of time will help assure many years of trouble-free operation from your system. We've worked hard to provide you with a reliable product that is affordable, compact, simple to operate and easy to maintain—the rest is up to you.

Contact us:

Be sure to fill in the enclosed warranty card and return it to us as soon as possible. This is required to fulfill the terms of your warranty. For Customer Service, or information about this and other products from Katadyn, please use our toll-free phone numbers or visit our website at www.katadyn.com.

Katadyn North America

9850 51st Avenue North
Minneapolis MN 55442

Phone: 800-755-6701 or 763-746-3500

Fax: 800-548-0406 or 763-746-3540

Website: www.katadyn.com

Customer Service / Technical Support:

800-755-6701 or 763-746-3500; Option 5
(International Collect Calls Accepted)

Email: marine@katadyn.com

We suggest you keep a record of your Katadyn dealer's name, contact information, and the serial number of your watermaker in the space below:

Dealer Name: _____

Address: _____

Phone/Fax/Website: _____

Serial Number: _____

Table of Contents

System Description	2
Product Specifications	3
Energy Recovery	4
Installation	5
Installation DOs.....	5
Installation DON`Ts	5
Plan Ahead for Manual Operation	6
Installation Procedures	6
Using your Watermaker	9
Powered Operation.....	9
Manual Operation.....	11
Special Conditions.....	12
Maintenance and Service.....	13
Pump Maintenance.....	13
Prefilter Maintenance	14
Membrane Storage, Biociding & Cleaning	15
Seal Replacement.....	18
Troubleshooting Flowchart.....	24
Appendix.....	25
Glossary	25
Diagrams.....	26
Kits & Accessories	30
Service Log	31
WARRANTY	33

System Description

The Katadyn *PowerSurvivor 40E* watermaker system has several components. Refer to the *System Diagram (Figure A-1)* in the *Appendix* for an overview of the components of the system and their interconnections.

Motor/Drive/Pump/Membrane Assembly: At the heart of the watermaker system is a high-pressure, positive-displacement pump. The pump is powered by a reliable 12 (or 24) VDC electric motor. An oil-bath gearbox (drive assembly) converts the rotary motion of the electric motor to a powerful, reciprocating, linear motion for driving the pump piston. The pump pressurizes input seawater to approximately 800 psi (pounds per square inch). The high pressure forces product freshwater through a semipermeable membrane located in the membrane housing. All of these main components have been integrated into a single, compact piece of equipment—with low power consumption, quiet operation and a small footprint.

Prefilter Assembly: The prefilter assembly consists of one prefilter housing and a standard 30-micron prefilter element constructed of *polyester* fibers. Two standard elements are included with each system. In some exceptional circumstances, an optional second prefilter assembly with a 5-micron prefilter element may be needed (see *Kits & Accessories*). The prefilter assembly is separate from the pump, which allows it to be installed in a convenient and accessible location.

Valves: Two high-quality plastic 3-way valves are supplied. The prefilter 3-way valve selects between two input sources for the prefilter assembly (and pump):

- Clean seawater during normal operation
- An alternate intake line for inputting biocide or a cleaning solution

The product 3-way valve allows easy selection between the two required destinations for the product freshwater:

- A freshwater collection tank for normal operation
- A convenient drain location for testing and discarding product freshwater, biocide and cleaners

Note: If you collect and discard the product freshwater at the same location, manually directing the output from the product freshwater hose may be the most practical approach. In this case, the product 3-way valve need not be installed.

Hoses and Hardware: Each *PowerSurvivor 40E* watermaker is shipped with hardware sufficient to perform a normal installation. The 3/8" I.D. reinforced plastic hose is used for seawater intake and reject brine. The smaller, 3/16" I.D. clear plastic hose is for routing product freshwater. There are also hose clamps and mounting bracket hardware for the prefilter assembly.

Customer-supplied Equipment: Every installation represents a unique challenge. You or your installer will have to provide:

- a reliable source of clean seawater for input to the prefilter 3-way valve
- plumbing to an appropriate drain location for the reject brine water
- a plumbing solution for your freshwater collection tank.

Our Promise: Every Katadyn *PowerSurvivor 40E* watermaker includes a three-year factory warranty and a long history of outstanding customer support. Our reputation for providing a quality product—along with service when and where you need it—is unequaled in the industry. Of course, you may never need us—but, if you do, we'll be there.

Product Specifications

Power Requirements:	4 amps @ 12 VDC; 3 amps @ 24 VDC*	
Construction:	316 Stainless Steel Pump Housing	
Rate of Water Production:	1.5 U.S. gal./hr.	(5.6 liters/hr.)
	±15% @ 13.8 VDC	
Feed Water Flow Rate:	15 U.S. gal./hr.	(56 liters/hr.)
Pump Weight:	25 lbs.	(11.3 kg.)
Pump Height:	6"	(15.2 cm.)
Pump Length:	17.5"	(44.5 cm.)
Pump Width:	16"	(40.5 cm.)
Pre-filter Housing Dimensions:	12" x 6"	(30 cm. x 15 cm.)

* The electric current requirement is an average figure. Instantaneous current will vary during a complete cycle of the pump. Also, upon initial installation, you may experience modestly higher current draw. Within a matter of hours, the average current draw should settle at the above specification.

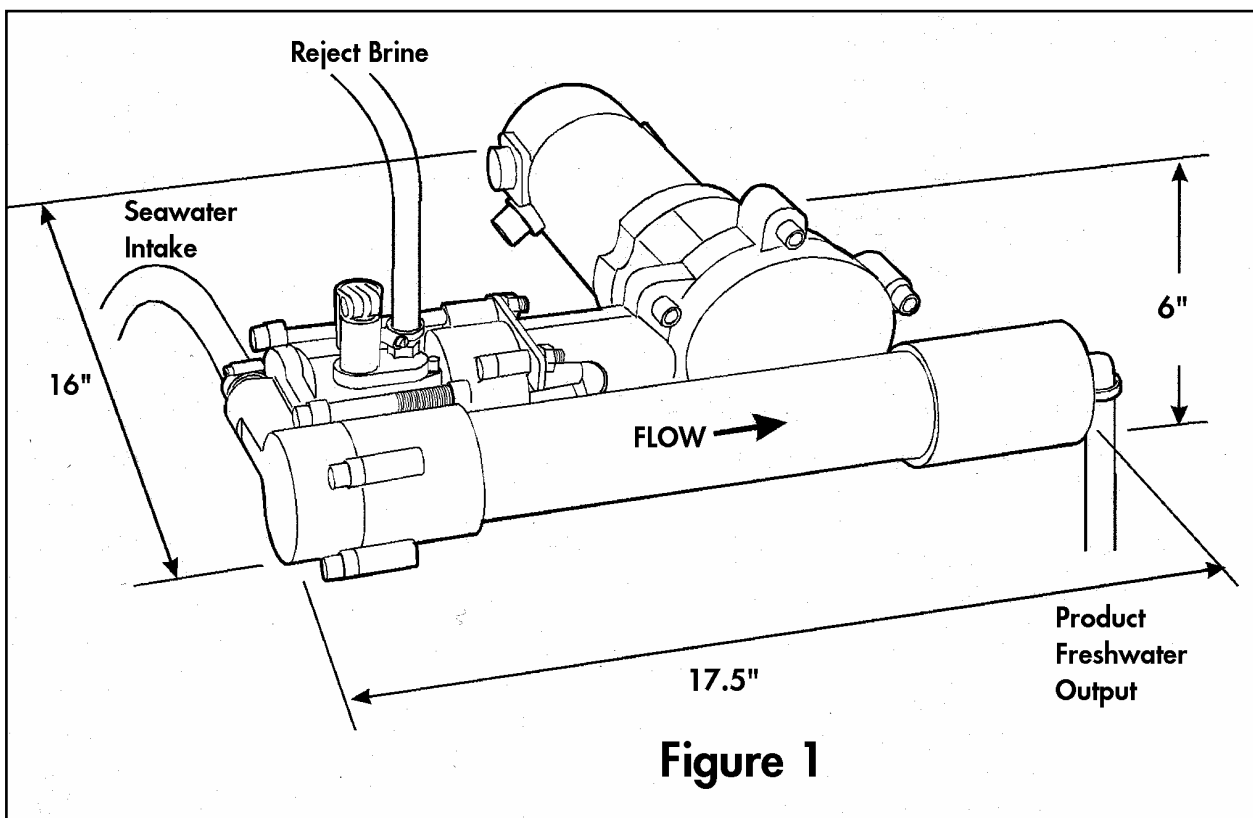

Energy Recovery

The technology behind Katadyn reverse osmosis watermakers

Reverse osmosis desalination was first developed over three decades ago. It was a major breakthrough in desalting technology, but the original process required a lot of power. By recovering 90% of the energy lost in conventional reverse osmosis systems, we've made small desalinators practical, so you can have freshwater when and where you need it.

Conventional Reverse Osmosis Desalination

The lower left portion of **Figure 2** shows the basic principle of reverse osmosis desalination. When saltwater is forced through a semipermeable membrane at high enough pressure—typically 800 psi—pure water will pass through the membrane, but salts will not. The membrane acts as a barrier to contaminants such as salts, viruses and bacteria, separating them from the pure water.

When seawater is forced against a membrane, only 10% passes through as pure water. In a conventional system, the remaining waste brine stream, still under high pressure, passes through a pressure-reducing valve and is discharged overboard.

For every gallon of pure water made, up to ten gallons of seawater must be pressurized! Therefore, 90% of the energy used in conventional reverse osmosis is lost!

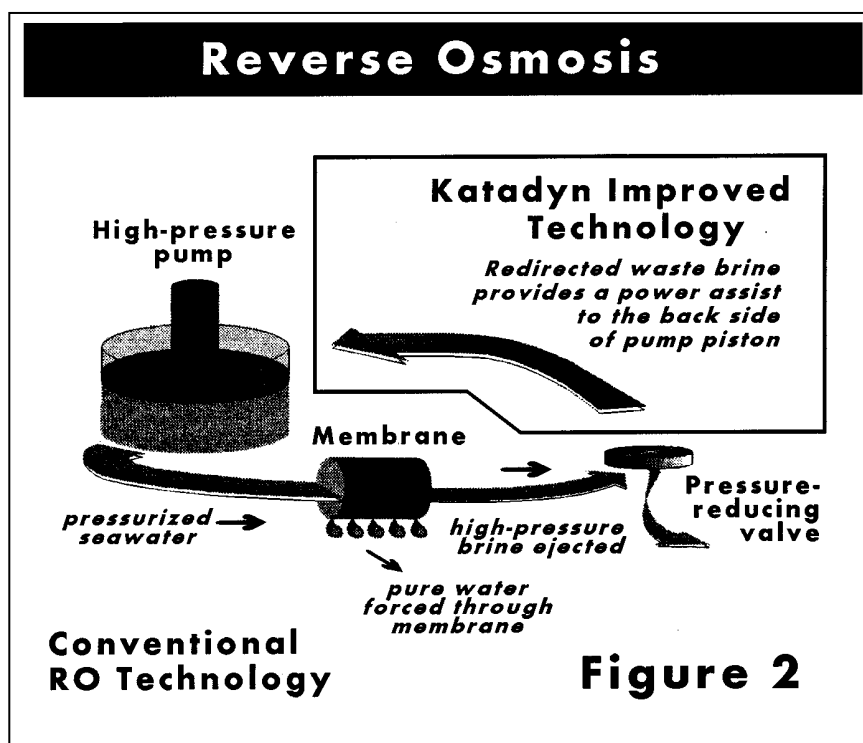

Figure 2

Energy Recovery Makes It Possible The upper right portion of **Figure 2** illustrates how Katadyn systems are configured to recover and effectively re-use the energy wasted in conventional reverse osmosis. The waste brine stream contains up to 90% of the energy expended. By recovering this energy, we are able to dramatically reduce the power needed to desalt seawater.

To do this, we developed and patented a high pressure *energy recovery* pump. It recycles the high-pressure brine by redirecting it to the backside of the pump's piston. By balancing the opposing force on the piston's front side, the brine provides a power assist to the pumping operation. Seawater can then be pressurized with much less effort.

Katadyn Watermakers Katadyn watermakers are simple, affordable, energy efficient and easy to use and maintain. The *PowerSurvivor 40E* represents the latest advancements in watermaker technology, featuring an improved oil-bath drive assembly, an all-316 stainless steel pump body, and simplified construction for easier and less frequent maintenance.

Installation

Do it right the first time and reap the rewards

The *PowerSurvivor 40E* watermaker utilizes a low-volume, high-pressure, *positive displacement* pump. Unlike the centrifugal pumps found in some systems, a positive displacement pump is self-priming. It can also draw water when mounted several feet above the waterline of a vessel. Thus, the watermaker may be installed in *almost* any location and orientation.

The most important part of a good installation is proper planning. Although the design and operating requirements of the *PowerSurvivor 40E* allow much latitude for equipment location, there are several cautions and suggestions you should consider before proceeding with an installation.

Installation DOs

When choosing a location for the watermaker drive/pump/membrane assembly:

- ☑ Avoid areas with excessive heat. Ambient temperatures *above 105° F (40° C)* exceed the ratings for the electric motor, and excessive heat can damage or destroy the membrane.
(**Note:** Most engine rooms get hotter than 105° F!)
- ☑ Choose a dry area. The motor/drive assembly is not waterproof and can corrode.
- ☑ Choose an area free of fuel vapors. The electric motor is not vapor-proof and ***should not be operated if explosive or flammable materials are present!***
- ☑ Find a location which allows comfortable access for routine inspection and servicing.

In addition, you should:

- ☑ Install the prefilter assembly in an *easily accessible* location! It needs regular (sometimes *daily*) inspection and maintenance. For ease of routine maintenance, the choice for this location is probably the single most important decision you will make—plan it carefully!
- ☑ Provide a shutoff valve or seacock in the seawater intake line.
- ☑ Install a coarse strainer in the seawater intake line.
- ☑ We recommend using properly-sized ring terminals and a terminal strip near the pump to connect electric power. This allows for easy testing, removal and servicing when required.

Installation DON'Ts

- ⊗ Don't use a thru-hull installed high on your vessel's hull for your source of seawater intake. This is especially important for sailboats. Even a normal amount of heel when under sail can cause the thru-hull to be out of the water, allowing air into the intake system. A rolling anchorage can do the same.
- ⊗ Don't locate the pump assembly above gear or materials that could be damaged if it leaked.
- ⊗ Don't locate the pump assembly near to sleeping quarters, bunks, or other areas that are normally "quiet" areas for yourself or crew members.

Plan Ahead for Manual Operation

The *PowerSurvivor 40E* watermaker was never intended to be part of a vessel's "Abandon Ship" equipment. Its capability for manual operation is useful when normal ship's power is unavailable. If you perform a typical installation, it is unlikely that you would have time to remove the watermaker when abandoning ship. Katadyn produces other desalinators that are specifically designed to be part of your survival equipment. Please visit our website for information on the *Survivor 35* and *Survivor 06* watermakers, both of which are intended for inclusion in survival kits.

Before finalizing your installation plans, consider how you would manually operate your watermaker, should the need arise. You will require a source of seawater input and a place to drain the reject brine, as well as a product freshwater collection container. Typically, the watermaker will have to be moved to a location convenient for manual pumping. There are two common approaches to implementing such an arrangement:

- During your installation, leave adequate service loops in the three hoses to allow the watermaker to be moved to a nearby location convenient for manual operation. This arrangement eliminates the need to disconnect any of the hoses.
- Prepare a separate set of hoses to be used during manual operation (recommended). This approach allows the watermaker to be moved to any location for manual operation.

More than likely, the plan you choose will be dictated by the location of the space available. In any case, consider how you would manually operate your watermaker before finalizing your installation plans.

Installation Procedures

Although every installation has custom aspects, the following general instructions should be useful to the typical installer. Refer to **Figure A-1** (in the *Appendix*) for information on parts identification and system connections.

1. Install Pump: After reading the comments on the preceding pages, decide on a location for the main pump/drive assembly. It should be mounted with the long axis of the membrane housing in a horizontal position. The purpose of this requirement is to avoid two problems:

- If the pump develops a seawater leak and is located directly above the drive assembly, the drive assembly and/or electric motor may be damaged (**Figure 3, left**).
- If the drive assembly develops an oil leak and is located directly above the pump, oil may find its way into the pumping system and damage the membrane (**Figure 3, right**).

We recommend securely thru-bolting the pump/drive assembly to a sturdy bulkhead or platform, using corrosion-resistant 1/4" fasteners with flat washers (See **Figure A-1**). Pick a location that allows ample space for routing the required hoses and electrical wires to the pump and motor.

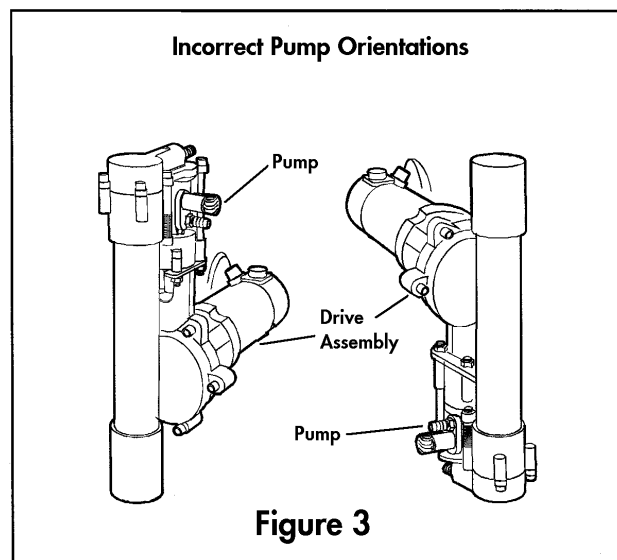

Figure 3

2. Connect Electrical Power to Pump: To provide 12 (or 24) VDC electric power to the motor, use a minimum of 16-gauge stranded copper wire. We recommend 14-gauge (or larger) wire for distances over 5-6 feet. Tinned, stranded copper wire is preferred for marine installations and is available in most marine hardware stores. **Figure 4** shows a typical electrical power configuration.

3. Mount Prefilter Assembly and 3-Way Valve: Lightly coat the male threads of the middle port of the prefilter 3-way valve with a non-hardening, paste-type thread sealant (e.g., *Permatex*®) to assure an airtight seal. (**Note:** teflon tape is *not* recommended.)

1. Carefully thread the middle port of the prefilter 3-way valve into the "IN" port of the prefilter housing. *Do not overtighten* this connection. When assembled correctly, the long axis of the 3-way valve should be vertical (See **Figure A-1**).
2. Fasten the supplied right-angled mounting bracket for the prefilter assembly to a bulkhead. Orient it so the prefilter assembly will be vertical, with the bowl underneath. We recommend that it be thru-bolted with corrosion-resistant hardware.
3. Screw the top of the prefilter housing to the bracket with the supplied screws. One port of the prefilter 3-way valve should project above the housing through the notch in the mounting bracket.

4. Install Seawater Intake Plumbing: There are two common approaches to providing the seawater intake circuit:

- Tee into an existing seawater intake (e.g., engine cooling water or manual seawater pump inlet).
- Install a dedicated thru-hull for the watermaker.

Either of these configurations should meet the following criteria:

- It should be at a low point on the vessel's hull, to minimize the chance of air intake during heeling or rough conditions.
- The thru-hull should be a minimum of 1/2" I.D., and possibly larger if it is a shared inlet. (**Note:** If there is the possibility that in the future you will want to upgrade to a higher capacity unit—or perhaps a second *PowerSurvivor 40E* to implement redundant systems—you should consider substituting 1/2" I.D. hoses and hose fittings during your initial installation).
- An easy-to-reach seacock should be installed on the thru-hull immediately inside the hull.
- A coarse seawater strainer is strongly recommended. It should be easy to reach and clean.

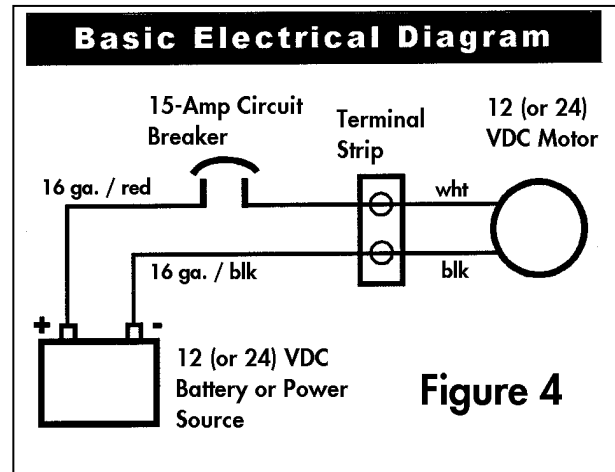

Figure 4

- The easiest and most commonly used approach is to tee into an existing seawater intake system. Because the flow rate and volume of seawater intake for the *PowerSurvivor 40E* are both extremely low, the pump can be adequately supplied by *most* pre-existing intakes—even inlets that operate at modest negative pressures, such as the cooling water inlet for an engine or generator.

When teeing into an existing seawater supply, we recommend installing a separate seacock or valve (in addition to the one at the thru-hull) to independently control the supply to the watermaker.

5. Install Reject Brine Plumbing: The reject brine water can be teed into an existing scupper or sink drain hose for draining overboard. Use the 3/8" reinforced hose and supplied hose clamps. A tee of the correct size will have to be supplied. Alternatively, a dedicated thru-hull may be installed at a convenient location. In this case, we recommend that a seacock be installed at the thru-hull.

6. Install Product Freshwater Plumbing: Your product freshwater plumbing design should allow for both saving and discarding of product freshwater. This normally requires (1) a drain location and (2) a container for collecting good product freshwater.

In no case should the product freshwater hose be permanently plumbed into the ship's potable water storage tank(s), without providing a way to reject the product freshwater when necessary. Note that product freshwater should *always* be rejected during the first few minutes after startup, and especially after biociding or chemical cleaning. For that reason alone, a means must be provided for disposing of unwanted product freshwater.

In general, we do not recommend that the output of product freshwater be routed directly into a vessel's freshwater storage tank(s). If for any reason the watermaker should fail during operation, there is a good chance that the entire supply of freshwater in the storage tank could become contaminated by unpurified seawater. This is especially important if:

- you have only a single tank for storing potable water.
- you will be making extended offshore passages and depending on your watermaker for your potable water supply.

The preferred method for collecting product freshwater is to use portable 5- or 6-gallon jerry jugs or a separate "day tank," which is isolated from the main storage tank. Some method should be devised for testing the product freshwater quality at the beginning *and at the end* of each operation. When you are certain that the quality of the collected product freshwater is acceptable, it can be transferred to the main storage tank.

Note: The important concept is to always have a minimum quantity of known-good potable water available at all times, either in your main storage tank or in the collection container(s). The length of your expected voyage and maximum distance from a source of potable water will determine the size of the adequate minimum amount. Arrange your watermaking schedule to assure that you always have the minimum of known-good potable water on board in one or both of your containers.

To route the product freshwater output of their watermakers, many users simply run a single 3/16" I.D. hose directly from the output hose barb on the membrane housing to a single location, where the water is tested and either discarded or run into a collection container.

Should you prefer to have your product freshwater output routed to two separate locations for testing/discarding and collection, the watermaker system includes a product 3-way valve for use in your output plumbing. Refer to **Figure A-1** for a routing diagram.

Using your Watermaker

Watermakers like to be run often

Just like its predecessor, the *PowerSurvivor 35*, the *PowerSurvivor 40E* watermaker can be operated in either *manual* or *powered* mode. This dual-purpose feature of the watermaker has its roots in our original products, which were designed as military-quality survival equipment. Our deep experience in this technology, combined with many years of active user feedback, allowed us to design a watermaker that is easy to operate with little or no technical knowledge. There are no complicated adjustments to make or gauges to monitor. By following the instructions below and paying attention to system maintenance, you can expect years of trouble-free operation.

Powered Operation

Pre-Run Checklist: Before running your watermaker, always check the following:

- ☑ Any valves in the seawater intake, reject brine and product freshwater lines should be open.
- ☑ Check for bad (“rotten egg”) smell from the water in the prefilter assembly. Replace the element and clean the housing, as required. Also check for foul water in any in-line coarse strainer.
- ☑ Assure that the product freshwater output is routed to a drain for testing/discarding.
- ☑ Check battery or power supply voltage. Operating your watermaker below about 11 VDC is hard on the electric motor and dramatically reduces the output of product freshwater.
- ☑ Observe the seawater around your vessel. Is it clean enough to use for your seawater intake? There are several things to avoid feeding to your watermaker:
 - petroleum products, such as oil, fuel, thinners, paints, paint removers, etc.
 - chlorine-treated water; e.g., most “dock” water
 - silty water—water contaminated by fine, hard, suspended particulates
 - putrid water, “red tides”, or any seawater that smells or looks contaminated
- ☑ Make sure the cleaning valve lever on the pump is in the “down,” or “run,” position.

It is important to remember that the watermaker is designed to process *clean, open-ocean seawater*. Any departure from that standard for your seawater intake runs the risk of causing excessive wear or damage to internal pump parts and/or the vulnerable reverse osmosis membrane, or producing contaminated product freshwater.

Note: Judging the quality of seawater input always involves a certain calculated risk. We know of watermaker systems that have been destroyed far offshore by intaking fresh whale excrement or oil contaminants from natural seepages—still, the chance of such things happening is normally small. On the other hand, regularly running a watermaker in an enclosed marina or harbor runs a much higher risk of harmful contamination. If you need to test a new installation while in a marina or harbor, monitor the water quality around your vessel carefully while testing. Most of the time you should be able to run the watermaker safely for enough time to check out the system. *Don't sail away without testing a new installation!*

Startup and Run: Turn on the electric power to the watermaker. If there is air in the seawater intake plumbing, the pump may require several minutes to draw up enough water to fill the hoses, prefilter housing, pump and membrane housing. Since the pump is self-priming, there is no need to prime the system prior to running.

Shortly after the hoses and prefilter housing have filled with seawater, reject brine water should start discharging from the pump. When all air has been forced out of the system (which may take several minutes more), product freshwater should begin to flow from the hose barb at the end of the membrane housing. Test and reject the product freshwater until the water quality is acceptable. When good quality water is flowing continuously, direct the product freshwater output to your freshwater collection tank. Continue to run until the desired quantity of water has been produced.

Shutdown and Storage: When the desired amount of water has been produced, the product freshwater quality should be checked again. If water quality is good at both the beginning and end of the run, it is likely that the collected water is good and can be safely transferred to the ship's potable water storage tank.

If you plan to run the watermaker again within a couple of days, it can simply be turned off. If you do not intend to use your watermaker again within a week, it should be treated with biocide to prevent bacterial growth on the membrane.

Note: Bacterial growth is much more rapid in warm or tropical climates. If using the watermaker in a tropical environment, we recommend a biocide treatment if the watermaker will not be run again within the *next three days!* Before doing repairs or maintenance work on a PowerSurvivor, close the seawater inlet valve after turning off the system. Otherwise, the possibility exists that hose failure, for example, could cause the boat to sink.

At the end of a watermaker run, check the condition of water in the prefilter housing. If there is evidence of trapped material, clean the prefilter housing and install a clean prefilter element.

Manual Operation

Manual operation of the *PowerSurvivor 40E* is useful if the ship's electric power supply fails. Use the following instructions to convert your watermaker to manual operation:

1. Jog run the watermaker and stop it when the piston has traveled the maximum distance away from the pump, toward the drive assembly.
2. If necessary, disconnect the seawater intake, reject brine, and product freshwater hoses (**Figure 5**) and move the watermaker to a location convenient for manual operation.
3. Slide the black rubber boot on the piston shaft toward the pump to expose the coupling pin. Pull or tap out the coupling pin which connects the pump piston shaft to the drive slider shaft (**Figure 6**). The pin is a fairly loose fit and should come out easily. Be careful not to lose it!
4. Using a 1/2" wrench, remove the four hex nuts holding the pump body to the drive assembly. Separate the drive assembly from the pump body and set the drive unit aside. Remove the black rubber boot from the piston shaft.
5. Align the holes in the handle bracket with the two pump bolts that are located above the piston shaft (**Figure 7**). Slide the bracket over the bolts and secure it with two of the hex nuts that held the drive assembly to the pump body. Do not overtighten these nuts.
6. Remove the clevis pin from the free end of the linkage attached to the handle assembly. Line up the holes in the handle linkage with the hole in the piston shaft. Insert the clevis pin through the linkage and the piston shaft and secure with a split ring (**Figure 8**).
7. Orient the hole in the handle (located above the linkages) between the holes in the handle bracket. Insert the second clevis pin through the holes and secure with the split ring (**Figure 9**).
8. If not already attached, connect the seawater intake, reject brine, and product freshwater hoses to be used for manual operation.

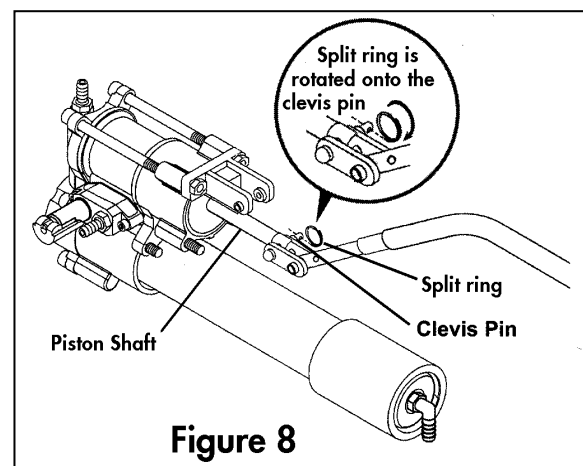
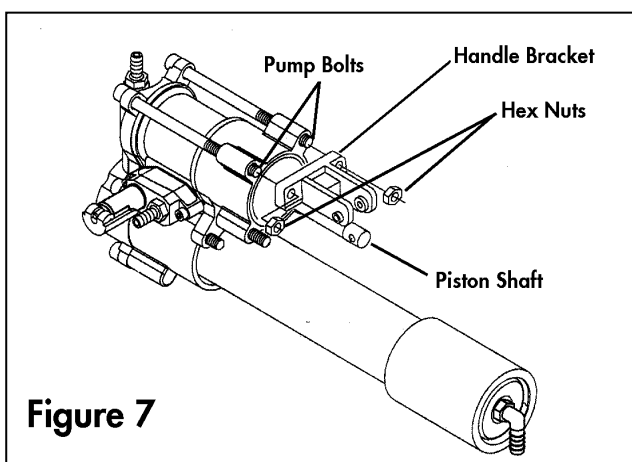
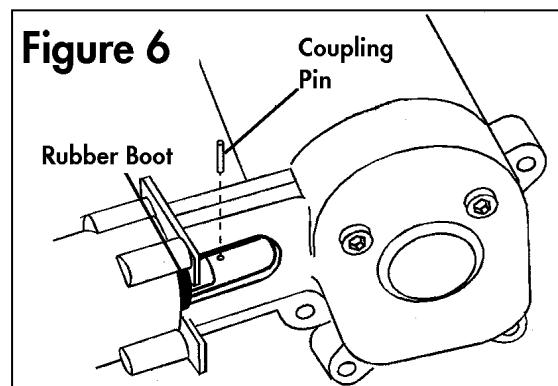
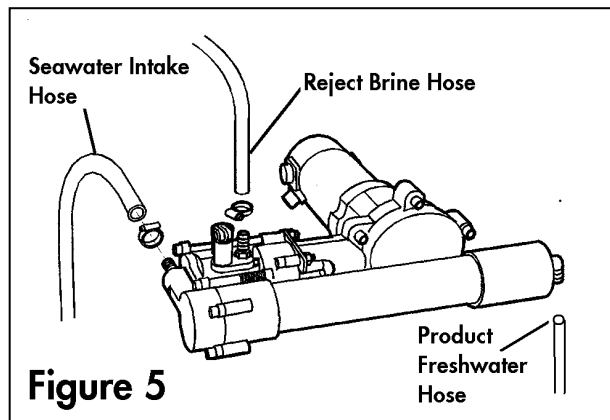

9. Operate the pump handle back and forth through its full range of travel in both directions. Pump at a rate of approximately one complete cycle every two seconds (one second in each direction). This is about the same rate at which the pump is driven by the motor during powered operation. Do not pump too fast!

10. To return the watermaker to powered operation, reverse the above procedure. When coupling the pump piston shaft to the drive shaft, align the hole in the piston shaft with the mating hole in the drive shaft, insert the coupling pin, and slide the rubber boot over the pin to hold it in place. Then secure the drive assembly to the pump with the four hex nuts. Tighten the nuts evenly. Do not overtighten.

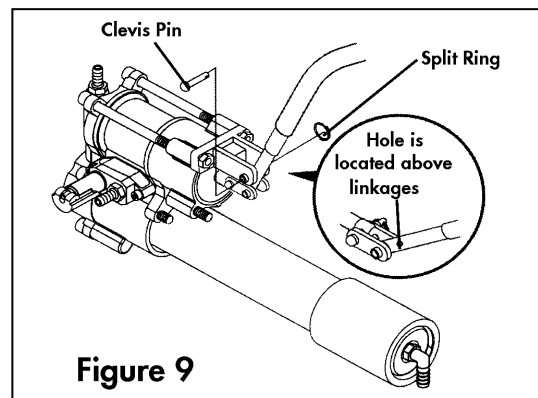

Figure 9

Special Conditions

Product freshwater output volume will vary somewhat, depending on the salinity and temperature of the seawater being processed. **Figure 10** illustrates the relationship between feed water temperature and the quantity of product water. Factors which are known to affect output or performance include:

- **High Salinity** will decrease output slightly and lead to a modest increase in current draw. Effectively, the pump must work harder to remove a larger percentage of dissolved solids from the seawater.
- **Cold Water** will have an effect similar to that of high salinity.
- **Silt or Sand** can damage the membrane and internal pump components if not removed during prefiltration. If you must regularly process such water, consider installing a Silt Reduction Kit (see Kits & Accessories).
- **Foul Intake Seawater** can seriously effect the quality of the product freshwater. The watermaker membrane is designed to remove the impurities found in clean, open ocean seawater. Processing of seawater with other kinds of impurities (1) may *not* remove those impurities and (2) may damage or destroy the membrane. See *Maintenance and Service: Prefilter Maintenance* below for more information on typical problems associated with foul water intake.
- **Low Battery Voltage** will dramatically reduce the volume of seawater throughput and product freshwater output. We recommend not operating the watermaker if battery voltage is below 11 VDC.

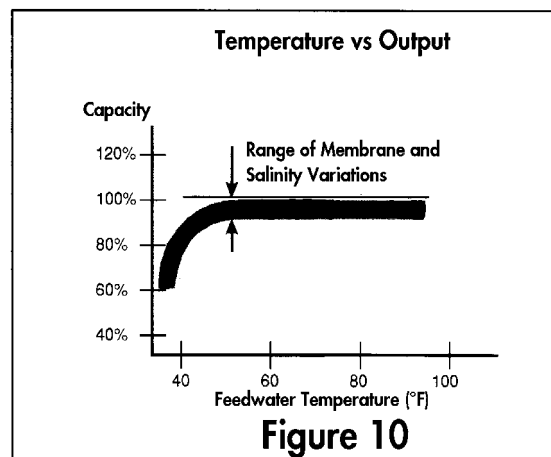

Figure 10

Note on Red Tides: In many areas of the ocean, a phenomenon generally known as a "red tide" can occur. This generic name is used to describe an invasion of local waters by huge populations of micro-organisms, which turns the seawater red. Occasionally, a red tide is accompanied by the death of local fish and other sea life, which can cause serious local pollution of the seawater. Although the watermaker membrane can remove the microorganisms that cause the red tide, it can *not* remove *all* of the chemical pollutants caused by large-scale biological decomposition. Therefore, we do not recommend using the watermaker to process seawater when a red tide is present.

Maintenance and Service

A little love goes a long way

We've worked hard to design a product that is simple to operate and maintain. However, regular attention to the few maintenance requirements of this equipment is critically important. This section of the *Owner's Manual* describes both the routine and the long-term maintenance requirements of the *PowerSurvivor 40E*.

Much of our knowledge of maintenance requirements, watermaker performance, and potential problems is a result of feedback from actual users over many years. Following these instructions will help keep your product freshwater quality good and your watermaker running trouble-free.

Pump Maintenance

Once properly installed, the main watermaker pump and drive assembly requires little attention. You should regularly inspect the equipment and check for any leakage of seawater, or oil leaks from the drive assembly. Any leakage is a sign of a problem and should be corrected.

Make certain that the watermaker remains dry. Exposure to saltwater can cause rapid corrosion of the drive assembly and/or damage to the electric motor. Keep all electrical connections clean, dry and tight.

After every 1000 hours (approximately) of use, replace the seals in the pump (See *Seal Replacement* below). After approximately 5000 hours of use, have the electric motor inspected for brush wear and commutator condition.

Pump Piston Shaft Lubrication: It is extremely important to lubricate the pump piston shaft periodically, especially after cleaning the membrane. The piston shaft is visible at the side of the drive assembly, where the pump connects to the drive (see **Figure 11**). Jog run the watermaker and stop it when the piston shaft is at its point of farthest travel away from the pump (i.e., towards the drive assembly). Assure that the watermaker is off and can not be started accidentally while you work. Clean the exposed piston shaft with a clean rag and lubricate the shaft with non-petroleum silicon lubricant.

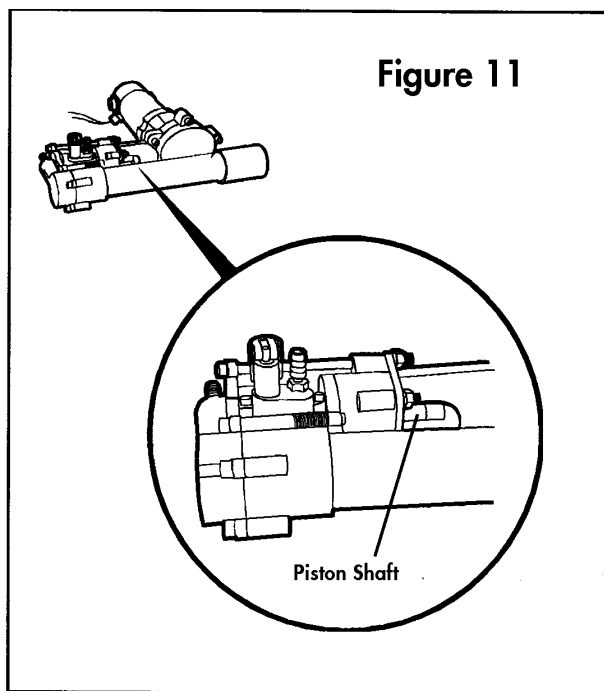

Prefilter Maintenance

Background: Maintaining a healthy watermaker largely involves taking proper care of the prefilter assembly and seawater intake plumbing. Failure to do so is the most common cause of the two most frequent types of watermaker “failure” we hear about: (1) producing diminished or no freshwater output, or (2) producing “bad-smelling” product freshwater. Here is what happens:

No Freshwater Output: The most common cause of diminished or no product freshwater output is air entering the seawater intake system at some point. The pump volume is small and the pressure required to press water through the membrane is rather high (about 800 psi). Since air is highly compressible, a very small amount of air can keep the pump from producing enough pressure to produce product freshwater. Periodically inspect and test the entire seawater intake system to assure that all joints and fittings are airtight, especially the connections at the prefilter assembly. (**Note:** Be aware that a stable air gap at the top of the prefilter housing is not uncommon, and doesn’t necessarily mean that air is getting to the pump itself.)

Bad-smelling Product Freshwater: The purpose of the prefilter assembly is to trap any particulates in the intake seawater that are larger than 30 microns. A coarse strainer (if installed) performs the same chore for contaminants of larger size. In each case, trapped material remains in the prefilter housing (or strainer bowl) until removed.

Much of the trapped material is organic: plankton, seaweeds and flotsam of all types. After a watermaker has been turned off, this material soon begins to decompose. As it does, it breaks down into a number of chemicals composed of smaller molecules. Some of these molecules are small enough to pass through the watermaker membrane along with the product freshwater. Perhaps the best-known example of such a chemical is hydrogen sulfide, a gas which (in small concentrations) smells like “rotten eggs.”

Two main factors affect the speed with which these products of organic decomposition will contaminate a watermaker system: (1) the ambient temperature and (2) the quantity of trapped material. We realize that many users of our equipment run their watermakers in near-shore situations while anchored. The amount of trapped material is usually high in such locations, and the prefilter assembly will require more frequent attention. Moreover, the high ambient temperatures in tropical locations greatly accelerate the rate of such decomposition. Users in temperate climate areas or users processing open-ocean seawater during offshore passages are less likely to require the same diligence.

Prefilter Maintenance: At the *end* of each run of your watermaker, examine the prefilter assembly (and the coarse strainer, if installed) for trapped material. If anything is visible, perform the following procedure:

1. Unscrew the prefilter housing, remove the dirty prefilter element, and discard the water in the bowl. Do not lose the large o-ring at the top of the bowl.
2. Clean the inside surface of the prefilter bowl. Inspect and clean the o-ring at the top of the bowl. Lubricate the o-ring and the threads of the prefilter housing with a light coat of silicon grease.
3. Install a clean filter element and screw the prefilter bowl back on securely.

Warning: If you purchase after-market filter elements, be certain they are made from *polyester* fibers. In particular, be wary of elements made of paper materials. They look very similar, but are designed for use with other types of water purification systems and are harmful to the membranes and high pressure pumps used in reverse osmosis watermakers. Be certain you purchase only polyester filters of 30-micron (or finer) size.

4. If the watermaker will not be used within the next three days, treat it with biocide (see *Biocide Treatment* below).
5. Tie a line through the center of the dirty filter element and, if underway, tow it behind the vessel for a few minutes. If the vessel is anchored, hang the dirty filter over the side of the boat so that it is underwater, and jerk it up and down a few times to dislodge the contaminants.
6. Dry the filter element thoroughly, preferably in the sun. Then store it for use as a clean filter the next time the prefilter assembly is serviced.

We do not recommend scrubbing filter elements with brushes or other abrasive tools or materials, as such treatment is unnecessary and greatly shortens the life of the filter element. If filter elements are cleaned regularly as directed, and not allowed to become extremely dirty, they can be expected to last for many months of service with nothing more than the gentle cleaning described above. Clean filter elements also help assure unrestricted flow of intake seawater to the pump.

Membrane Storage, Biociding & Cleaning

The reverse osmosis membrane inside the membrane housing is an expensive and delicate component of your system. When properly cared for, it can be expected to last for several thousand hours of use. Improper use, maintenance or handling can damage or destroy the membrane very quickly.

Biocide Treatment: The primary purpose of a biocide treatment is to kill biological growth and bacteria that are present inside the membrane. It also functions as a membrane wetting agent for extended storage. Over time, bacteria can multiply and adhere to the membrane surface, thus gradually decreasing its effectiveness. When the watermaker is not to be used for an extended period of time, it should be biocided. A biocide treatment is effective for approximately **one year** (storage temperature < 25°C/77°F). If longer storage is required, the biocide treatment should be **repeated every year**.

Warning: Be sure to follow the flushing procedures described below to ensure that the biocide solution does not get into the freshwater supply.

In temperate climates, the maximum period of time the watermaker should be stored without biociding is approximately one week. In hot or tropical climates, the watermaker should be biocided if it will not be used within the next three days. Follow these directions to perform a biocide treatment of your watermaker:

1. Lift the lever on the cleaning valve on the pump to place it in its "clean" or "up" position (see **Figure 12**).
2. Fill a clean plastic container or bucket with two quarts (approximately 2 liters) of clean water. Freshwater is preferable, but clean seawater may be used if freshwater is not available.

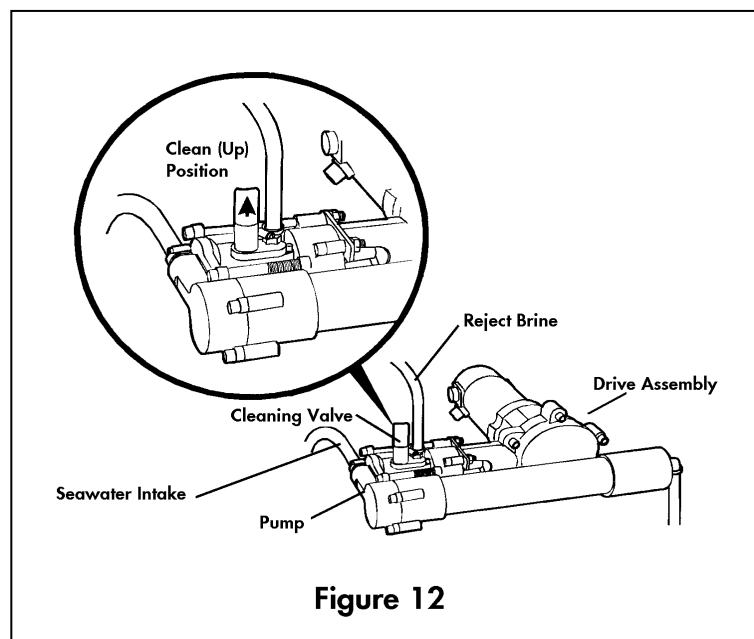

Figure 12

(Caution: Never use chlorinated freshwater. This may damage the membrane.)

3. Mix two spoonful (approximately 20 grams, or 1% by weight) of dry *Biocide* chemical with the water in the container and stir until completely dissolved.
4. Use your product 3-way valve (or move the product water output hose) to be sure that any water flowing from the product freshwater output is properly discarded.
5. Turn the lever on the prefilter 3-way valve to the alternate intake position. Run the 3/16" alternate intake hose with the strainer attached into the container of biocide solution.
6. Turn on the watermaker and run it until almost all of the biocide has been drawn from the container and foamy biocide solution is ejecting from the reject brine hose. If there is a chance that the watermaker will be subjected to freezing conditions, continue to run until air is being ejected from the reject brine hose. (**Note:** If the membrane freezes, it must be slowly and completely thawed before the watermaker may be used again.)
7. Turn off the watermaker. It is now ready for storage for up to one year.

If seawater was used instead of freshwater, repeat the biocide procedure with freshwater as soon as possible. Repeat the above procedure at least once a year if the watermaker is not being operated.

Cleaning the Membrane: We do not recommend casual or regular cleaning of the reverse osmosis membrane in the watermaker—it should only be done when needed. Under normal use conditions, when only open-ocean seawater is being processed, cleaning the membrane should rarely (or never) be necessary. Proper biocide treatments prior to extended periods of non-use will prevent biological growth on the membrane surface. Under these conditions and with proper care, a membrane can be used for years without requiring a cleaning.

Note: Buildup of deposits and reduction in product freshwater flow usually take place gradually over extended periods of time. Sudden reduction or stopping of product water output is rarely caused by a dirty membrane.

Cleaning the membrane is only necessary if contaminants are deposited on, and adhere to, the membrane surface in sufficient amounts to affect the output of product freshwater. Usually this condition also causes battery current to increase. There are two main types of such deposits and a different chemical cleaner is needed for each type:

- **Organic Growth**—usually caused by processing brackish water or failure to properly store a membrane during extended periods of non-use. Use ***Alkaline Cleaner***.
- **Mineral Scale**—caused by mineral impurities in the intake water supply. Use ***Acid Cleaner***.

The only indication that a membrane might benefit from cleaning is a substantial reduction in the quantity of product freshwater output, all other factors being normal (e.g., battery voltage, salinity, seawater temperature). The best way to detect such a problem is by keeping an accurate log of product freshwater output at known battery voltages. Such a practice is highly recommended.

If you have determined that your membrane needs cleaning and you know the type of deposits (mineral or organic), use the appropriate cleaner. If you do not know the nature of the deposits, try cleaning first with the ***Alkaline Cleaner*** and check for improvement in product freshwater output. If output remains poor, repeat the cleaning process using the ***Acid Cleaner***. Never mix the two types of cleaners! Always flush well with clean water between processes if performing both alkaline and acid cleaning. The following directions apply for both types of membrane cleaners:

1. Lift the lever on the cleaning valve on the pump to place it in its "clean" or "up" position (see **Figure 12**).
2. Discard any dirty seawater in the prefilter assembly. Clean the housing and install a clean filter.
3. Fill a clean plastic container or bucket with one gallon (approximately 4 liters) of clean water. Freshwater is preferable, but clean seawater may be used if freshwater is not available. (**Caution:** Never use chlorinated freshwater. This may damage the membrane.)
4. Mix four spoonful (approximately 40 grams) of either **Acid Cleaner** or **Alkaline Cleaner** (*not both!*) with the water in the container and stir until the cleaner is completely dissolved. The water should be warm, but not over 120° F (49° C).
5. Turn the lever on the prefilter 3-way valve to the alternate intake position. Run the 3/16" alternate intake hose with the strainer attached into the container of cleaning solution.
6. Disconnect the reject brine water hose from its drain (or use a separate length of hose) to route the reject brine water back into the container of cleaning solution during the following procedure.
7. Turn on the watermaker. Discard any solution coming from the reject brine hose for about 30 seconds. Then run the reject brine water hose back into the container of cleaning solution to allow recirculation of the cleaner.
8. Continue to run the watermaker for about 15 minutes, to assure that the cleaning solution is well circulated through the pump and membrane.
9. Turn off the watermaker and allow the membrane to soak in the cleaning solution for 5 to 10 hours, or overnight. For severe fouling, repeat steps 8 and 9 of this procedure.
10. When the soaking is finished, remove the reject brine hose from the cleaning solution container and run the watermaker again. Discard the first pulses of the reject brine water. When the reject brine flow becomes cleaner, return the reject brine hose to the cleaning solution container for recirculation.
11. Continue to run the watermaker and recirculate the cleaning solution for another 30 to 60 minutes
12. When cleaning is complete, turn off the watermaker. Reconnect the reject brine hose to its normal drain location.
13. Remove the alternate intake hose and strainer from the cleaning solution and place them into a container of clean, warm (non-chlorinated) freshwater. If freshwater is not available, clean seawater may be used if its temperature is above 68° F (20° C).
14. Turn on the watermaker and flush warm water through the system for 5 minutes.

If the watermaker will be stored for more than a week (three days in warm climates), it should now be treated with the biocide solution.

Seal Replacement

After approximately every 1000 hours of use, the watermaker should be partially disassembled, cleaned, and lubricated with non-petroleum silicon grease. At that time, the seals should be inspected and replaced, as required. The standard Repair Seal Kit (included in the Extended Cruising Kit—see Kits and Accessories) is available from Katadyn and most marine retail stores. It includes a complete set of replacement seals and other components for all user-serviceable parts of the watermaker.

It is unlikely that you will have to replace all of the seals contained in the kit at every servicing. The dynamic seals work harder and wear faster than others, and will need to be replaced more often. We recommend that you save old seals. Most of them are still useable and could be kept in a kit for emergency repairs.

Preparation: Before beginning to disassemble the watermaker, read the following instructions completely. Have a Repair Seal Kit on hand. Refer to the drawings in **Figures A-2, A-3 and A-4** in the *Appendix* to identify the major components of the pump and the parts contained in the kit to make sure none are missing. Prepare a clean flat workspace with good lighting. Have the following tools and materials available for a complete rebuild:

Tools Needed:

piston seal installation tool

1/2 " open-end wrench

5/8 " open-end wrench

1/4 " allen wrench

medium flat blade screwdriver

small standard pliers

small scissors

10x loupe or magnifier

silicone grease

included in **Repair Seal Kit**

clean rags

Disassembly:

1. Before beginning disassembly, run the watermaker and stop it when the piston shaft is at its farthest point of travel away from the pump (i.e., toward the drive assembly). This provides enough room for sliding the rubber boot toward the pump in Step 3.
2. Disconnect the pump from the drive assembly by first removing the two hex nuts and 5" sockethead capscrews from the check valve plate, using the 1/2" open-end wrench and 1/4" allen wrench. Also remove the two hex nuts securing the pump back plate to the drive assembly. See **Figure R-1**.

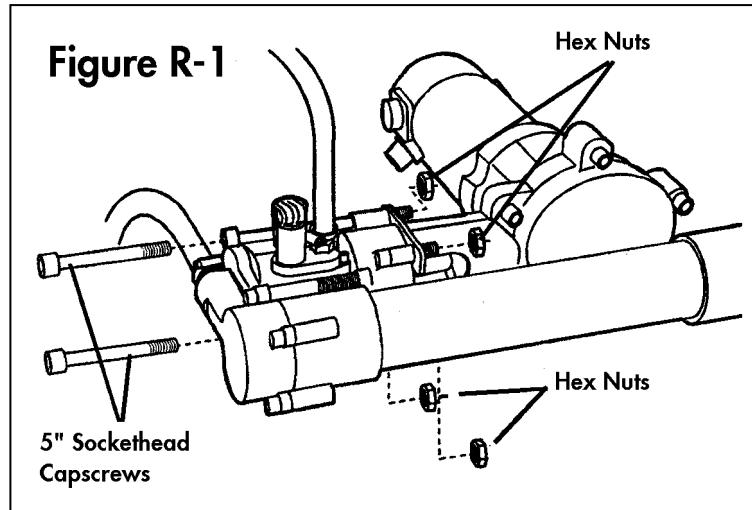

3. Slide the black rubber boot on the piston shaft toward the pump to expose the drive shaft coupling pin. Use a small allen wrench or similar tool to push the coupling pin out of the drive shaft (see **Figure 6**). Be aware that the coupling pin fits loosely in the drive shaft and may fall out when the rubber boot is removed. Be careful not to lose it. Separate the drive assembly from the pump and set the drive assembly aside.

4. Remove the two 3" socket-head capscrews using a 1/4" allen wrench. Separate the pump back plate and piston assembly from the pump body (see **Figure R-2**).

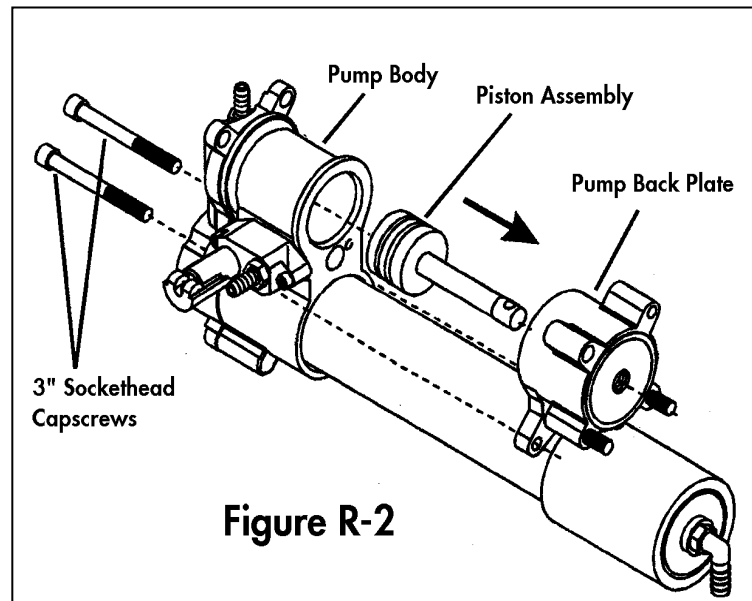

5. If the piston assembly remained with the pump back plate when it was removed, pull the piston out of the back plate and set it aside. If the piston stayed in the main pump body, pull it out of the cylinder. If the piston assembly is difficult to remove from the pump body, insert a small allen wrench or Phillips screwdriver through the coupling pin hole. This will provide a "t-handle" with a better grip for extracting the piston assembly. **Be aware not to damage the surface of the piston shaft.**

6. Remove the large o-ring (8012588) from its groove in the side of the pump back plate that faces the pump body. Remove the wiper block and spacer (if present) from the pump back plate. Use needle-nosed pliers to pull the old wiper block seal out of the wiper block. See **Figure R-3**. (Note: This seal is usually damaged during removal. Be sure you have a replacement on hand before removing it.)

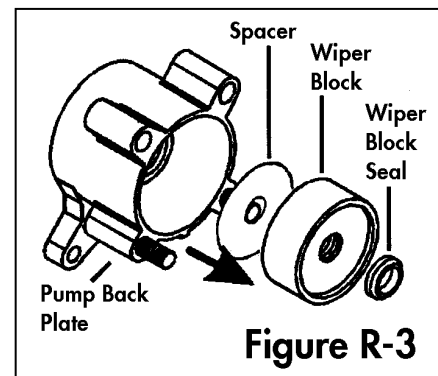

7. From the side of the pump back plate that contained the large o-ring, insert a round drift of slightly smaller diameter than the hole for the piston shaft. (Note: a small socket on an extension or a wooden dowel makes a suitable drift). Tap the drift with a mallet to drive the two backup washers, two piston shaft seals and the piston shaft bushing out of the pump back body. See **Figure R-4**.

8. Remove the remaining two 3/4" sockethead capscrews from the check valve plate using a 1/4" allen wrench. Separate the check valve plate from the pump body. If it is difficult to remove, try rotating the check valve plate 90°. This provides a better grip for pulling the check valve plate from the pump body.

9. After the check valve plate has been separated from the pump body, the membrane tube plug will remain in either the check valve plate or the pump end of the membrane housing. Use one of the following procedures to remove it:

A. If the membrane tube plug remains in the membrane housing, insert a hard, thin edge (e.g., a dull pocket knife) between the tube plug and the fiberglass molding of the membrane housing. Work the blade sideways to pry the tube plug out slightly, until there is enough of a gap between the tube plug body and the membrane housing to insert a flat blade screwdriver. Then use two screwdrivers on opposite sides of the tube plug to carefully work it out of the membrane housing. Avoid gouging or damaging the membrane housing or the tube plug.

B. If the membrane tube plug remains in the check valve plate, use a thin edge and/or flat blade screwdrivers, on opposite sides of the membrane tube plug, to carefully pry the plug out of the check valve plate. Avoid damaging the membrane tube plug.

10. Disassemble the valves in the check valve plate (see **Figure R-5**.) Use a 5/8" open end wrench to unscrew the intake valve seat. Remove the intake poppet valve and its spring. If necessary, use needle-nosed pliers to remove the poppet valve retainer. Then use the pliers to lift out the reject poppet valve and its seat. Grip the x-shaped ribs of the reject poppet valve and pull straight up. The seat will be pulled out along with the valve. After the reject poppet valve and its seat have been removed, retrieve the reject poppet valve spring from the bottom of the check valve plate cavity.

This completes the disassembly of all user-serviceable parts of the Katadyn PowerSurvivor 40E watermaker.

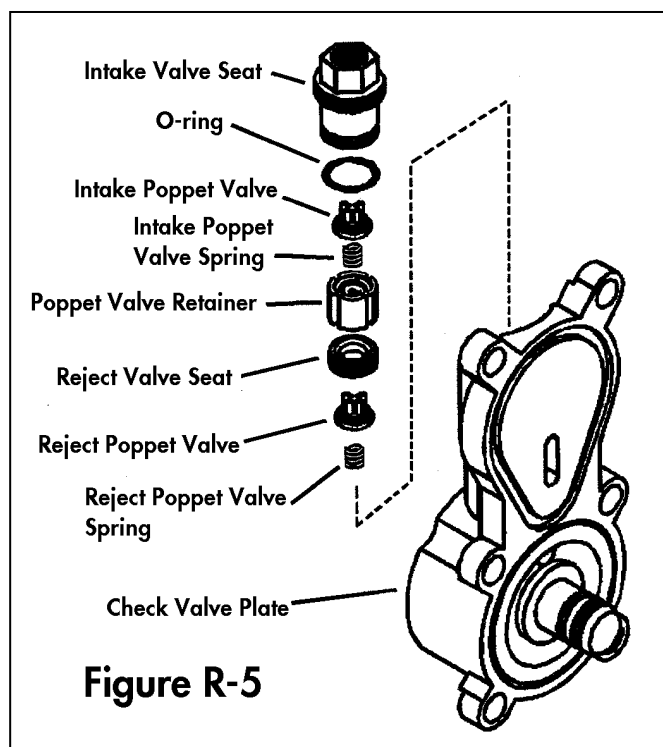
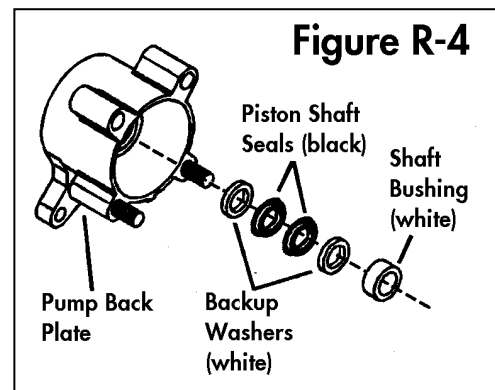

Reassembly: Before you begin reassembly of the watermaker, clean all parts using clean, lint-free rags. At this time, all parts should be carefully inspected for wear or damage. Use a 10x magnifier or loupe to examine the seals, o-rings and other small parts. Stubborn rust stains and other deposits on metal parts can be cleaned with a soft-metal wire brush (e.g., stainless steel or brass). Do not use polishes, cleaning compounds containing abrasive materials, or regular steel wire brushes. During reassembly, refer to **Figures A-3** and **A-4** in the *Appendix* for full-size drawings and identification of the components included in the Repair Seal Kit.

In the following procedure for reassembling the watermaker, it is assumed that all parts have been cleaned and that all o-rings, seals, and mating surfaces have been lightly lubricated with non-petroleum silicon grease (supplied with the Repair Seal Kit). References to the Repair Seal Kit will be abbreviated to "RSK."

Warning: Use only non-petroleum silicon grease to lubricate your watermaker. Lubricants with a petroleum base will damage several watermaker components, including the reverse osmosis membrane. Be especially cautious of lubricants that "contain" teflon, silicon, etc.—such products could also contain petroleum-based components. An ample supply of silicon grease is included with each RSK.

1. Make a note of the correct orientation of the old cup ring and PIP seal and then remove them from the piston assembly. Since these components are made of rather stiff rubber, it is usually easier to cut them off. Use a small screwdriver to wedge under the cup seal and pry it up. While holding it up, cut it with a small pair of scissors. Repeat this process for the PIP ring.

2. Refer to **Figure R-6** during the following procedure. Place the piston assembly on a flat, stable surface with the shaft pointing up. Slide the installation tool (provided in the RSK) over the piston shaft with the wide end down. Lubricate the new PIP ring, cup seal and the installation tool with silicon grease. With the grooved side facing up, slide the PIP ring down the installation tool and onto the piston. Repeat this process for the cup seal. Note that the grooved side of the cup seal should be facing down; i.e., the grooved sides of the PIP ring and the cup seal should be facing each other. When finished with the installation, remove the installation tool from the piston shaft.

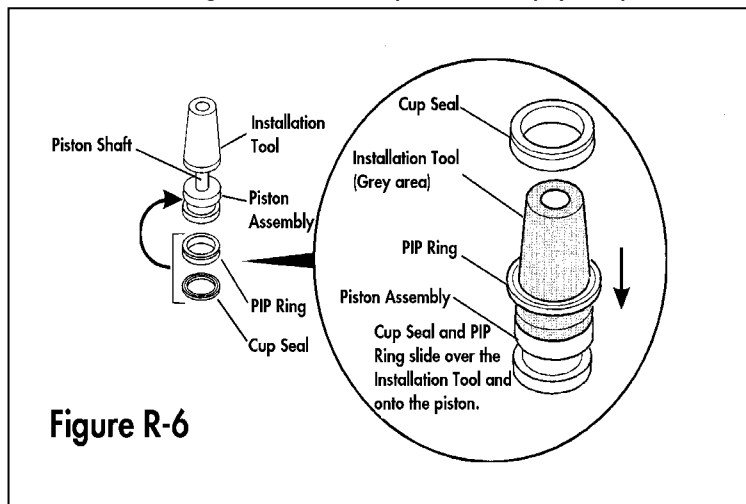

3. Lightly lubricate the cylinder in the pump body with silicon grease. Slide the finished piston assembly, shaft first, into the pump body from the side of the pump body that faces the check valve plate. Install the large o-ring (8012588) into its groove in the pump back plate and lower the pump back plate over the piston shaft. The side of the back plate with the large o-ring should be facing the pump body. See **Figure R-7**.

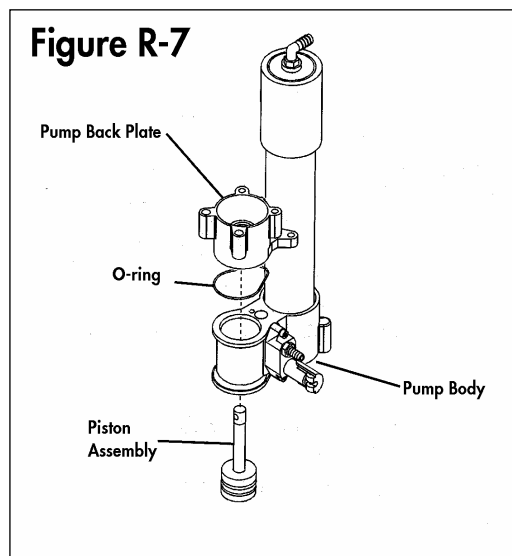

4. Refer to **Figure R-4**. Slide one of the white backup washers over the piston shaft and press it into its bore in the pump back plate. Next, slide one of the two black rubber piston shaft seals over the piston shaft and work it into the bore on top of the backup washer. Note that the shaft seals are flared out on one side. It is important that the flared (wider) side should be down, facing the shaft bore. Install the second piston shaft seal in exactly the same way. It too should be installed with its flared side facing down. Next, install the second white backup washer and, finally, the white bushing. Slide the installation tool (used in Step 2 above) over the piston shaft with the narrow end facing the white bushing. Use the installation tool to press the shaft washers, seals and bushing all the way into the bore. When finished, the outside end of the bushing should be flush with the bore opening.
5. Install a new wiper block seal into the wiper block. The seal must be pressed into a groove inside the bore in the middle of the wiper block with the narrower side of the seal facing outwards. Form the seal into an oval shape by squeezing it between your fingers and press one side of the seal into the groove in the wiper block. Once an edge of the seal is started into the groove, carefully work the rest of the seal into place. After the seal has been installed, slide the spacer (if present) and wiper block onto the piston shaft. The side of the wiper block from which the seal was installed should be facing outward. Refer to **Figure R-3**.
6. Prepare the check valve plate for reassembly by installing the new poppet valves. Note that both the intake and reject poppet valves and valve springs are identical. Refer to **Figure R-5** during the following procedure:
 - A. Lower a new poppet valve spring into the bottom of the bore in the check valve plate. Use your little finger or the eraser end of a pencil to press it into its seat. It is designed to be a light press fit and, when installed correctly, it should stay vertical in place during the next step.
 - B. Use needle-nosed pliers to carefully lower one of the new poppet valves into the bore. The poppet valve should rest on top of the spring with the poppet's cross side facing up.
 - C. Lower the new reject valve seat into the bore and use a finger to press it down as far as it will go. Note that the hole in the middle of the valve seat has a beveled edge on one side. The side with the beveled edge *must* face downward; i.e., it must face the poppet valve. When properly installed, the valve seat should fit neatly over the poppet valve. Test the poppet valve by pressing it with the eraser end of a pencil. It should move up and down slightly and seat squarely in the valve seat.
 - D. Locate the small depression in the center of one end of the poppet valve retainer and press the second valve spring into the depression. It was designed as a light press fit and should stay in place after being installed. Then lower the poppet valve retainer into the bore in the check valve plate with the spring facing upward.
 - E. Lower the second poppet valve into the bore in the check valve plate and rest it carefully on top of the valve spring.
 - F. Remove the old o-ring (8013015) from the intake valve seat and replace it with the new one from the RSK. Carefully screw the intake valve seat into the check valve plate and tighten with a 5/8" open end wrench. Use the eraser end of a pencil or a small allen wrench to test the operation of the intake poppet valve. The poppet valve should move down slightly and then spring back up against its seat.

7. Replace the two large o-rings (8012947) and the two smaller o-rings (8013006) on the membrane tube plug with new o-rings from the RSK. Insert the small end of the membrane tube plug into the exposed hole in the membrane element (which should have been left installed in the membrane housing) and press the tube plug into the membrane housing as far as it will go. The ridge on the outside of the tube plug should be flush against the end of the membrane housing.
8. Press the piston as far as it will go toward the pump back plate. Install a new o-ring (8012588) into its groove in the check valve plate.
9. Press the check valve plate over the exposed end of the membrane tube plug. If necessary, rotate the check valve plate to align it accurately with the pump body and install the 3/4" and the 3" sockethead capscrews. Check that the two large o-rings (8012588) in the check valve plate and the pump back plate are still seated in their grooves and then tighten the four capscrews evenly with a 1/4" allen wrench.

10. Slide the two 5" sockethead capscrews through the holes in the check valve plate and the back plate. Slide the rubber boot onto the piston shaft. See **Figure R-8**.

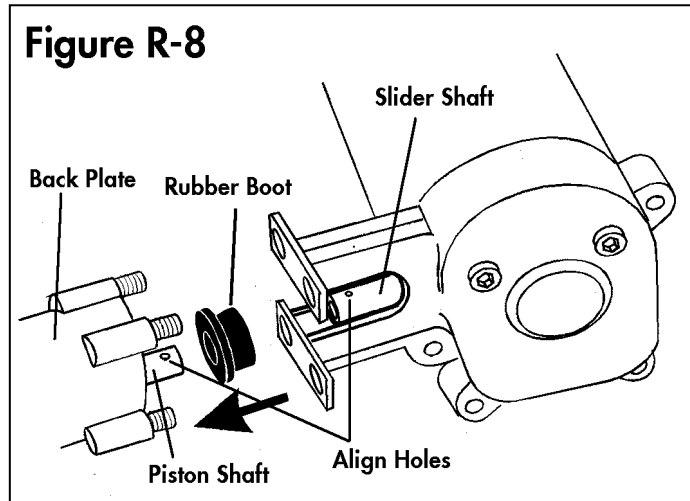

11. Insert a small screwdriver or an allen wrench through the hole in the piston shaft and rotate the shaft to align its hole with the hole in the slider shaft of the drive assembly. When they are aligned, slide the holes in the drive assembly bracket over the studs projecting from the pump back plate. Insert the coupling pin through the aligned holes in the slider shaft and piston shaft. Push the rubber boot over the coupling pin to hold it in place.

12. Install the four hex nuts on the studs projecting from the pump back plate through the drive assembly bracket and tighten evenly with a 1/2" open-end wrench and 1/4" allen wrench. *Do not overtighten these fasteners!*

13. To replace the o-rings beneath the cleaning valve assembly, refer to **Figure R-9**. Unscrew the two sockethead capscrews using a 5/32" allen wrench and remove the assembly from the pump body. Remove old o-rings (8012594) and (8012697) and replace them with new o-rings from the RSK. Replace the cleaning valve assembly on the pump body and install the two capscrews. This completes the procedure for reassembly of the watermaker. When operation is commenced again, carefully inspect the watermaker for proper operation and any leaks or other signs of incorrect assembly.

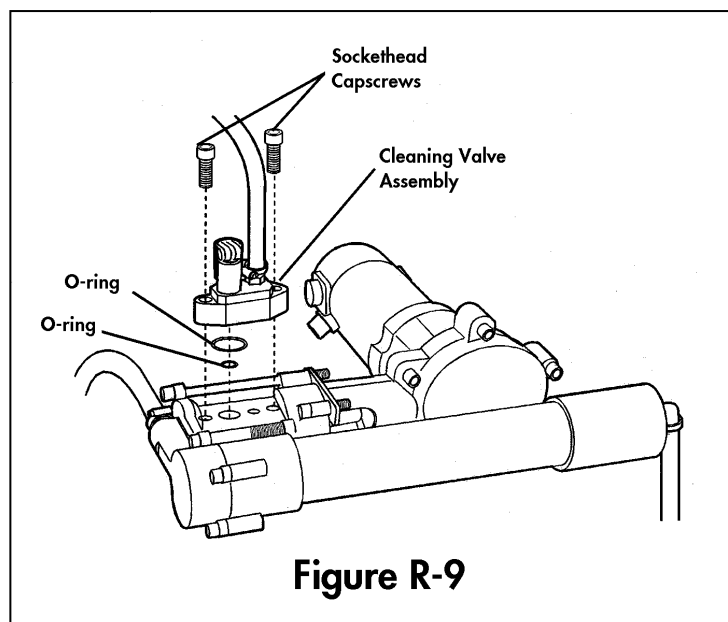

Troubleshooting Flowchart

Use the flow chart below to diagnose and solve the most common problems associated with use of the *PowerSurvivor 40E* watermaker. The information in this chart is a distillation of the experience of many users, our field representatives, and customer support staff. Use it first if you encounter a problem. If the problem persists, our Customer Support department is ready to help.

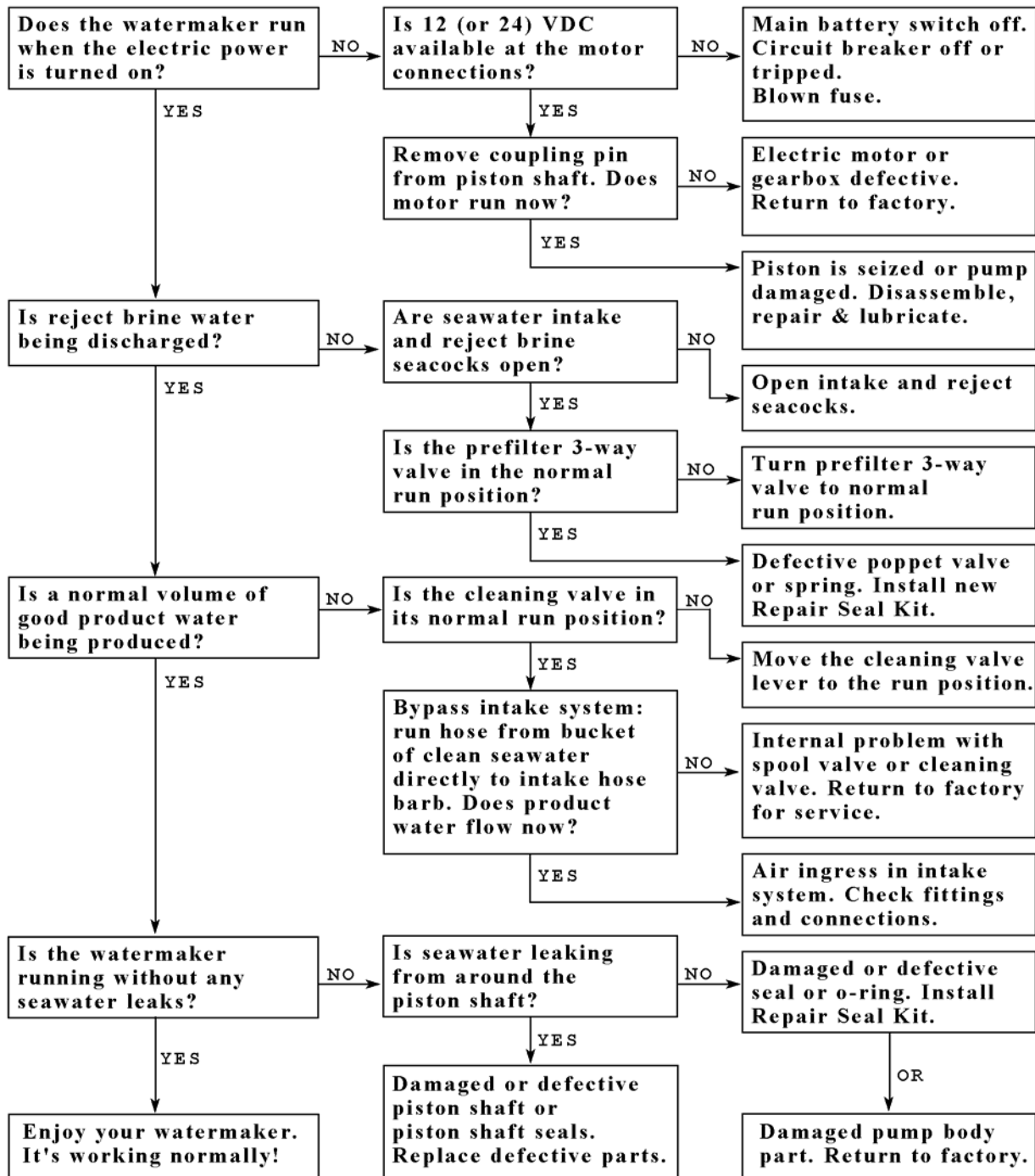

A collection of useful information for the Katadyn watermaker owner

Glossary

Biocide a chemical used to inhibit biological growth in the reverse osmosis membrane during storage or extended periods of non-use.

Filter a device which removes suspended solids from a fluid stream. A filter is *not* the same as a reverse osmosis membrane.

Micron a metric unit of measurement equal to one thousandth of a millimeter, or one millionth of a meter.

Osmosis the process of diffusion between two water sources through a semipermeable membrane, resulting in both water sources striving to reach an equilibrium in the concentrations of dissolved substances.

Pickling a slang term for the process of flushing the membrane with biocide solution (see Biocide).

Potable suitable for drinking, especially water. With regard to a desalinator, it is generally defined as water with 1500 ppm or lower of dissolved solids that is relatively free of harmful microorganisms.

PPM parts per million. Used as a measure of the quantities of substances dissolved in water.

Prefilter a filter placed in a desalinator system to remove suspended solids from the feed water before it reaches the high pressure pump and reverse osmosis membrane.

Pressure Relief Valve a valve that relieves pressure in a system to prevent damage to system components. In the *PowerSurvivor 40E*, the relief valve is set to open at 1000 psi, to prevent damage to the pump and membrane.

Product Freshwater potable water produced by the reverse osmosis process.

PSI pounds per square inch—a unit for measuring pressure.

Reverse Osmosis (RO) a reversal of the natural osmosis process between two fluids which occurs when water is forced under pressure through a semipermeable membrane. It produces potable water.

Salinity a measure of the amount of salts, minerals, and other dissolved solids contained in a water source. Salinity (see TDS) is measured in ppms.

Salt the common name for the chemical sodium chloride. Open-ocean seawater is about 3% dissolved salt, or about 33,000 ppm of sodium chloride.

Seal a device (such as an o-ring) used to prevent fluid leakage between two system components.

Semipermeable the characteristic of some materials (e.g., a reverse osmosis membrane) that makes them relatively porous to some substances while blocking the passage of others. Unlike normal filters, semipermeable membranes usually operate at the molecular or atomic level, allowing much finer “filtering” than simple mechanical filters.

TDS Total Dissolved Solids—a type of measure commonly used to indicate the purity of water, usually expressed in ppms. A standard TDS meter measures only the electrical conductivity of the water being tested. Therefore, it is only able to measure dissolved substances that are ionized in solution (e.g., sea salt). In particular, they do *not* indicate the presence of non-ionized substances, such as bacteria, viruses and many other soluble chemicals.

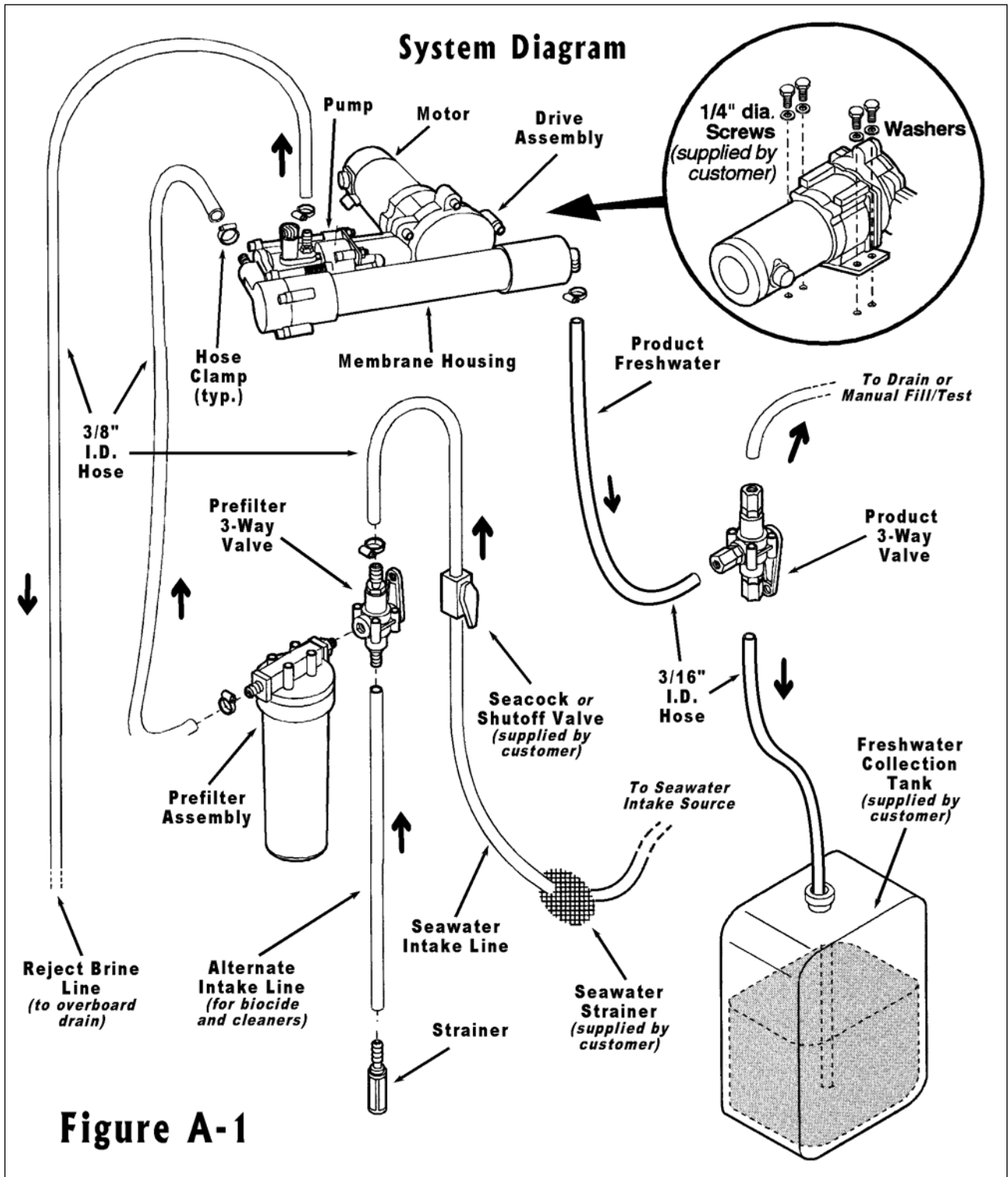

Pump Assembly Exploded Parts View

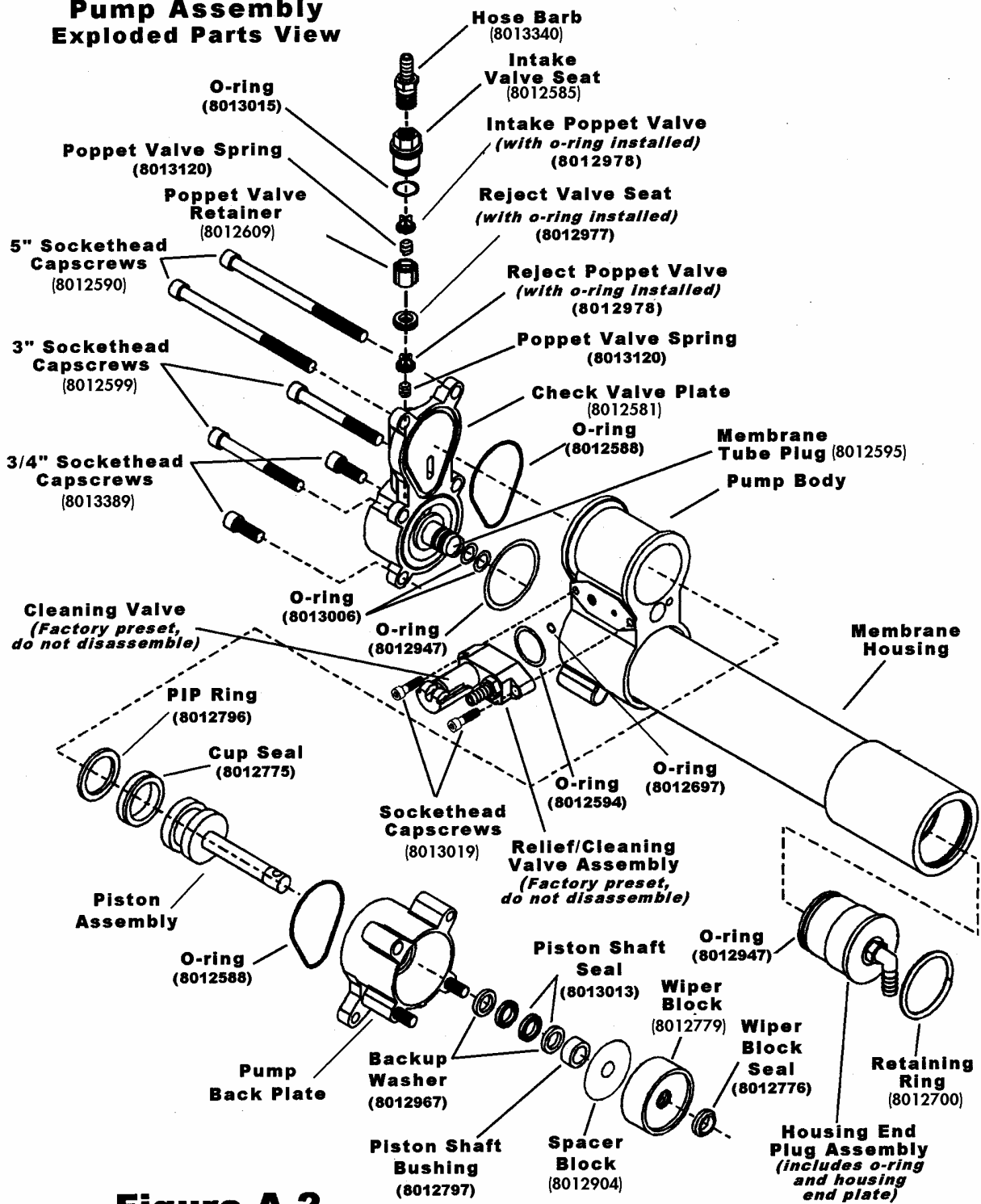
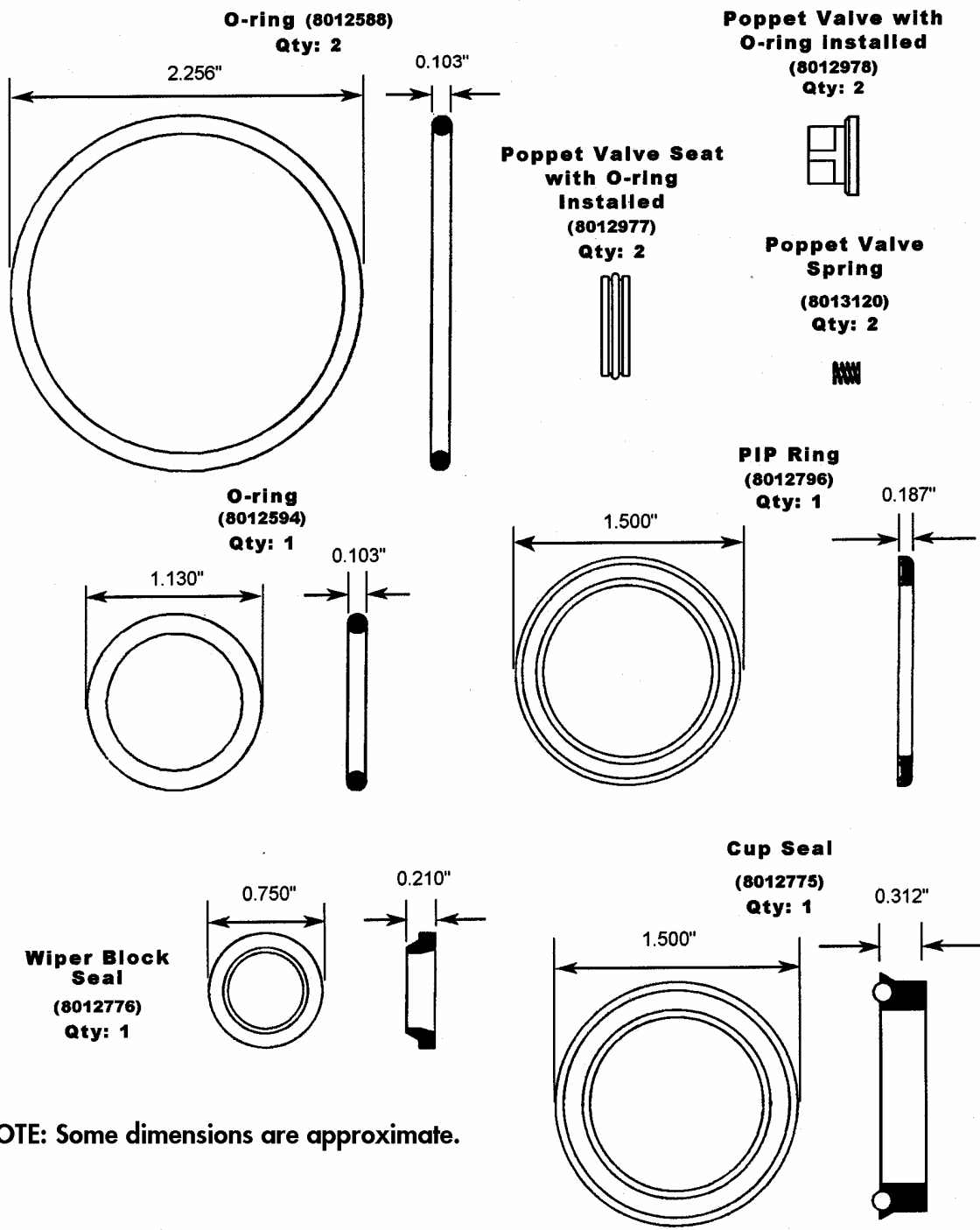
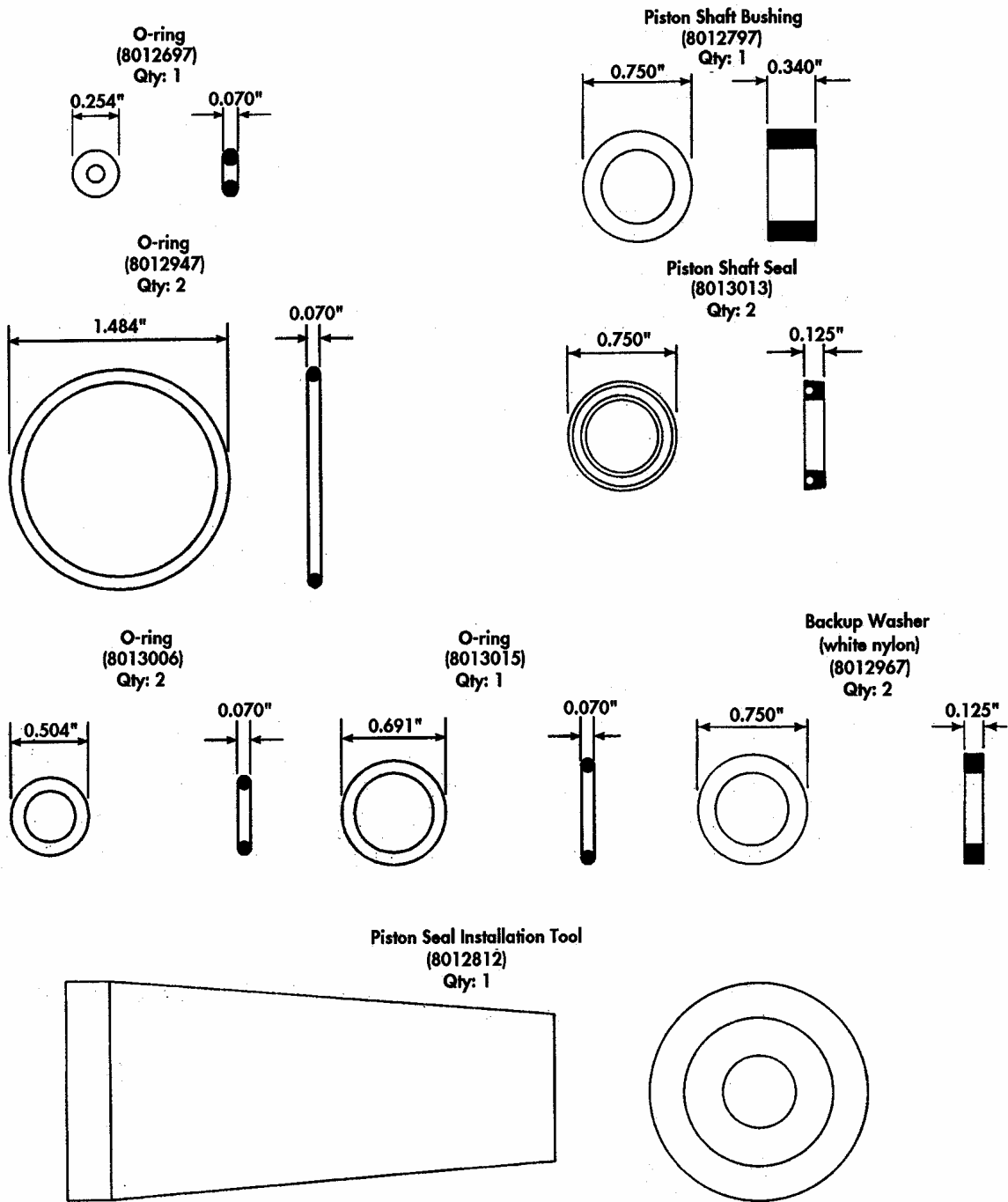

Figure A-2



NOTE: Some dimensions are approximate.

Figure A-3



NOTE: Some dimensions are approximate.

Figure A-4

Preventive Maintenance Package

Part # 8012607

An expanded cruise kit which includes all components of the **Extended Cruise Kit**, plus a **Silt Reduction Kit**. This kit is strongly recommended for extended cruising and variable water conditions.

Silt Reduction Kit

Part # 8012859

This kit is intended to protect the high pressure pump and reverse osmosis membrane from excessive exposure to silt and other suspended particulates. It should be used in brackish water, shallow water, inland waterways, areas of glacial runoff and other similar situations. The **Silt Reduction Kit** includes a 5-micron prefilter which follows the standard 30-micron filter supplied with the watermaker. Also included is a 1-amp boost pump to ensure adequate intake flow to the watermaker.

Extended Cruise Kit (Recommended)

Part # 8012606

Includes items needed for regular care and seasonal maintenance and/or storage. Contains (1) **Repair Seal Kit**, (1) container **Acid Cleaner**, (2) containers **Alkaline Cleaner**, (1) container of **Biocide** and (6) 30-micron prefilter elements.

Repair Seal Kit (Recommended)

Part # 8012610

A set of all user-serviceable seals and parts for the high pressure pump. This kit also includes replacement gear oil for the drive assembly. A **Repair Seal Kit** should be installed after each approximately 1000 hours of use.

Cleaning & Storage Chemicals

Acid Cleaner (8 oz.)	Part # 8013608	(1)
Alkaline Cleaner (8 oz.)	Part # 8013615	(1)
Biocide (8 oz.)	Part # 8013609	(1)

Note: You may order parts and kits through our retailers or from Katadyn North America directly at 800-755-6701. If ordering directly, you'll need to provide detailed shipping instructions as well as credit card information.

QUESTIONS? CALL 800-755-6701

WARRANTY

LIMITED WARRANTY FOR POWERSURVIVOR™ 40E WATERMAKER

THIS LIMITED WARRANTY AND THE REMEDY PROVIDED HEREIN ARE EXCLUSIVE AND IN LIEU OF ALL OTHER EXPRESS WARRANTIES AND, UNLESS STATED HEREIN, ANY STATEMENTS OR REPRESENTATIONS MADE BY OTHER PERSON OR FIRM ARE VOID. THE DURATION OF ANY IMPLIED WARRANTIES OF MERCHANTABILITY OR FITNESS FOR A PARTICULAR PURPOSE SHALL BE LIMITED TO THE DURATION OF THE EXPRESS LIMITED WARRANTY. NEITHER KATADYN NORTH AMERICA, INC. (KATADYN) NOR ITS AFFILIATES SHALL BE LIABLE FOR ANY INCIDENTAL, CONSEQUENTIAL OR SPECIAL LOSSES OR DAMAGES, RESULTING FROM THE USE OR INABILITY TO USE THE POWERSURVIVOR 40E WATERMAKER, WHETHER RESULTING FROM BREACH OF WARRANTY OR ANY OTHER LEGAL THEORY.

This Limited Warranty gives you specific legal rights, and you may also have other rights which vary from State to State. Some States do not allow limitations on how long an implied warranty lasts, or do not allow the exclusion or limitation of incidental or consequential damages, so the above limitations or exclusions may not apply to you.

What Is Covered: KATADYN warrants to the original purchaser that the PowerSurvivor 40E Watermaker enclosed with this Limited Warranty conforms to the manufacturer's specifications and is free from defects in workmanship and material for a period of three years from the date of original purchase. If the original purchaser transfers the PowerSurvivor 40E Watermaker to another person, this Limited Warranty will not be enforceable by the person to whom the product is transferred.

What We Will Do To Correct Problems: Should your PowerSurvivor 40E Watermaker prove defective during this period, you must notify KATADYN at 9850 51st. Avenue North, Minneapolis, MN 55442, or an authorized distributor or dealer of KATADYN. You must permit KATADYN or its representatives to make such investigation, examination and tests as KATADYN deems appropriate and, if requested to do so, you will return the product to the factory at the address set forth above. KATADYN's sole obligation under this Limited Warranty is, at its option, to repair or replace the defective unit, without charge for parts or labor. Postage, insurance or shipping costs incurred in presenting your PowerSurvivor 40E Watermaker product for warranty service are your responsibility.

What Is Not Covered: This Limited Warranty is contingent upon proper use and maintenance of the product; it does not cover products that have been improperly shipped or improperly installed, or that have been misused, abused, neglected, or improperly maintained, cleaned or stored, or that have been serviced other than by an authorized KATADYN distributor or dealer. The PowerSurvivor 40E Watermaker can be damaged by oil, grease, chlorine and certain other organic or inorganic substances. It must be cleaned carefully after use, and requires periodic maintenance. Failure to observe the precautions listed in the User's Manual may constitute improper use or maintenance of the product and causes this Limited Warranty not to apply. This Limited Warranty does not cover products from which the KATADYN label or logo or the rating label or serial number has been removed. This Warranty does not extend to normal wear or to replacement items, including but not limited to filter cartridges, pump seals and O-rings.