

NMEA Buffer with ISO-Drive NBF-2

The power to drive multiple NMEA devices, with the safety of full input and output isolation, providing networking peace of mind...

The Actisense™ NMEA Buffer is the best solution for buffering weak NMEA sources, allowing many NMEA devices to be driven, such as chart plotters, radars, and on-board laptop PCs.

The latest ISO-Drive technology has been added to the NBF-2 so that now each output is separately isolated from each other and ground, making this a world first and the safest buffer on the market.

This buffer is required wherever an NMEA source cannot provide sufficient power to drive all the equipment that requires the NMEA data it supplies. It is also ideal for safely interfacing an on board PC to all the NMEA equipment on a vessel, while providing total OPTO-Isolation.

Designed for use with all NMEA output types, including direct connection to a PC or laptop RS232 output, the NBF-2 buffer

produces an amplified copy of the input signal on each of its 6 Iso-Drive outputs.

Electrical spike protection is provided as standard on the buffer's input using full galvanic OPTO-Isolation to provide superior protection to the NMEA source device. The NBF-2 input exceeds all the requirements of the latest NMEA 0183 specification.

Tests have shown that each of the six ISO-Drive outputs can drive more than ten typical NMEA inputs, and more if they meet the full NMEA specification. They are also fully compatible with RS232 equipment, and automatically provide single-ended bipolar drive when connected to an RS232 device.

Uses

- Drive many NMEA 0183 devices
- Isolate your NMEA device for safety

- Upgrade a system by providing isolation between all listeners to solve data errors caused by ground loops

Features

- Low power
- Safe, fool-proof connections

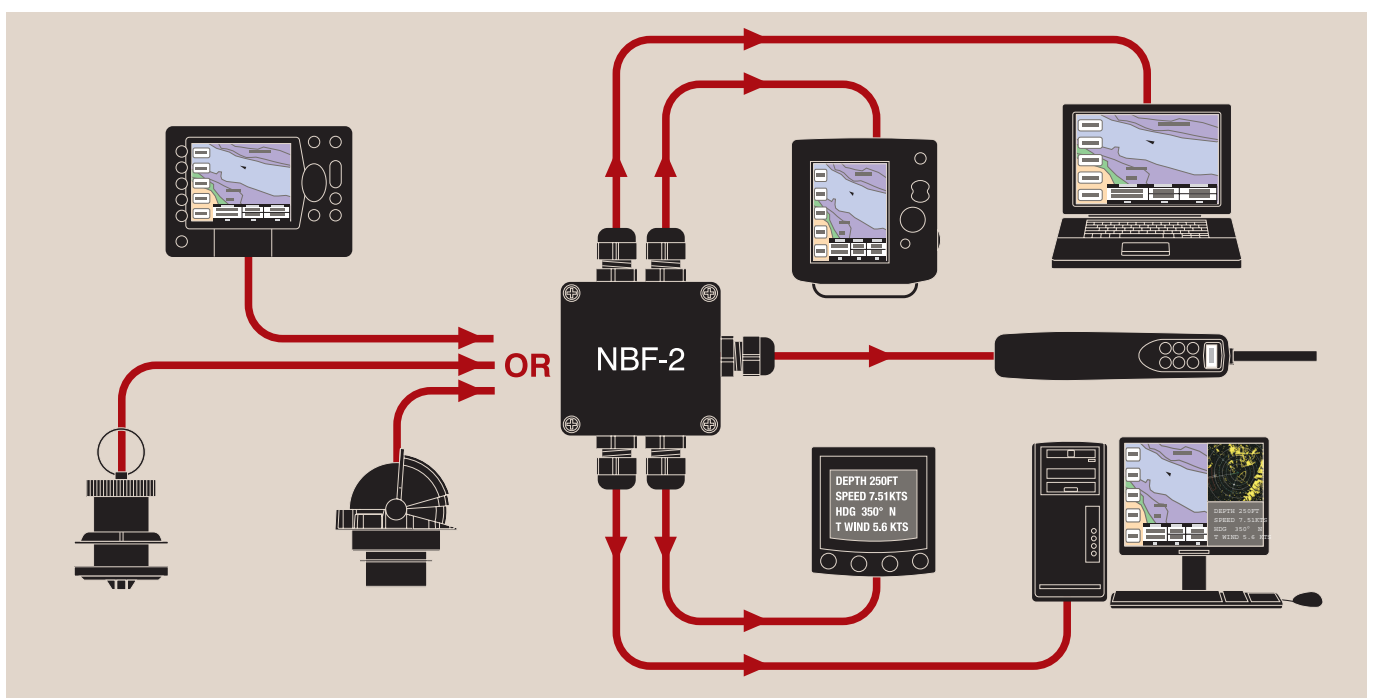
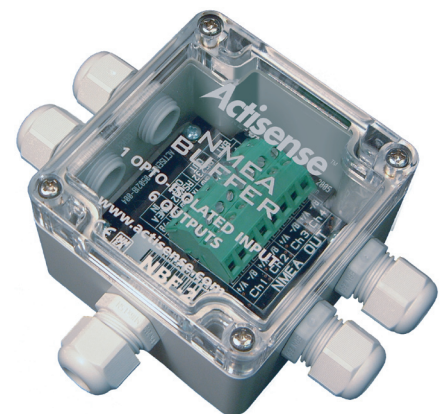

NMEA Buffer with ISO-Drive NBF-2

Specifications

OPTO Isolated Flexible Input

- Full galvanic opto-isolation offering up to 2.5kV DC protection from ground
- Compatible with PC (RS232) or Marine (NMEA 0183) data talkers
- Exceeds all NMEA 0183 input specifications - capable of receiving 1.8 volt differential signal levels while current drawn from talker is minimised
- Overdrive protection to 40 volts DC
- Baud rate selectable from 4800 to 115200

ISO-Drive Flexible Outputs (6)

- Electrically isolated from input power, OPTO input and all other outputs to 1.5kV ground potential difference
- Exceeds all NMEA 0183 output drive specifications
- Capable of driving more than 10 NMEA 0183 compliant listeners
- Can send data to PC (RS232) or Marine (NMEA 0183) listeners
- Current limited short circuit protection to NMEA 0183 specification (protects against cable short circuits)
- Static discharge protected

Baud Rates

- Baud rates up to 115200 are possible for full compatibility with NMEA 0183 version 3.0 (HS) and beyond

Built-in Firmware / Software

- No software required

Power Supply

- Supply voltage range: 10 to 35 volts DC
- Power consumption (@ 12v DC):
 - 44 mA minimum, no-load
 - 100 mA maximum, all outputs at full drive (100 ohm loads)
- Power consumption (@ 24v DC):
 - 25 mA minimum, no-load
 - 49 mA maximum, all outputs at full drive (100 ohm loads)

Environmental

- Recommended operating temperature: -20°C to +70°C
- Sealed case and grommets provide IP66 protection

General

- Weight: 200 grams
- Dimensions: see diagram
- Guarantee: 3 years

Part Number

- NBF-2

Dimensions

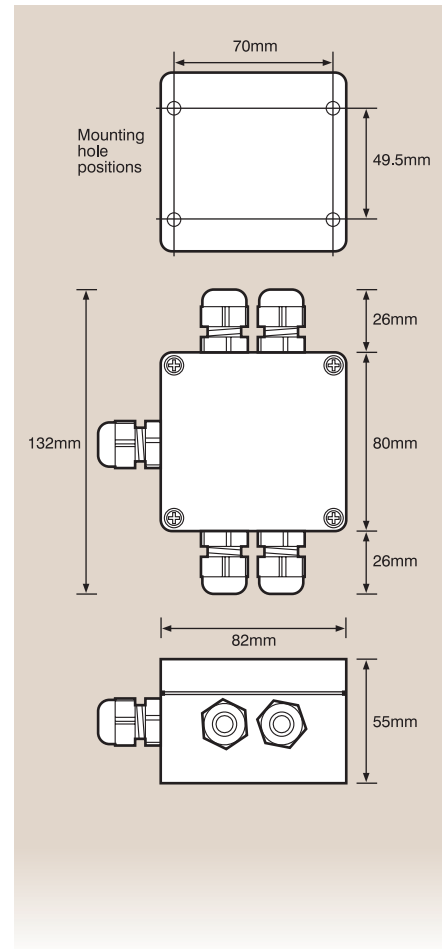

Active Research Limited
 Unit 5, Wessex Trade Centre
 Ringwood Road, Poole
 Dorset UK BH12 3PF

t: +44 (0)1202 746682
 f: +44 (0)1202 746683
 e: sales@actisense.com
www.actisense.com

