



NMEA Buffer

NBF-2-A

User Manual

Issue 1.00

- 1 Galvanically opto-isolated NMEA 0183 “Listener” data input for complete isolation of the input from ground, meeting all the specifications of the latest NMEA 0183 / IEC61162-1&2 specifications.
- 6 ISO-Drive “Talker” outputs, compatible with both NMEA 0183 (RS422 / RS485) and RS232 listeners.
- Compatible with NMEA 0183 standard and “HS” (AIS) baud rates, and speeds well in excess of this for special applications.

Contents

Important Notices	4
Notices	4
Foreword	4
Introduction	4
NMEA 0183 Introduction	5
Electrical specifications	5
Technical features	5
Connecting devices together	6
The basics	6
The NMEA signals	6
The different NMEA standards	6
Connections	7
Input Connections	8
NMEA 0183 Input	8
Connecting to the battery supply	8
Output Connections	9
NMEA 0183 / RS422 Outputs	9
Troubleshooting guide	10
Specifications	11
Company Information	12

Important Notices

The **Actisense™** NMEA Data Buffer (NBF-2) is intended for use in a marine environment, primarily for below deck use. If the unit is to be used in a more severe environment, such use may be considered misuse under the seller's warranty.

The NBF-2 has been certified to comply with the European directive for Electro-Magnetic Compatibility (EN60945), and is appropriately CE marked. Operation of the unit should be in conjunction with appropriate CE approved shielded connectors and cabling used in accordance with the CE directive EN60945. Any EMC related issues should be reported to Active Research immediately to allow the company to rectify or resolve EMC related problems in accordance with its obligations under EN60945.

If the unit is connected such that compliance failure occurs beyond the company's control, the company shall not be held responsible for compliance failure until suitable EMC guidelines for connection are seen to have been taken.

Notices

When using this document, keep the following in mind:

The products described in this manual and the specifications thereof may be changed without prior notice. To obtain up-to-date information and/or specifications, contact Active Research Limited or visit the **Actisense™ website (www.actisense.com)**.

Active Research Limited will not be liable for infringement of copyright, industrial property right, or other rights of a third party caused by the use of information or drawings described in this manual.

All rights are reserved: The contents of this manual may not be transferred or copied without the expressed written permission of Active Research Limited.

Active Research Limited will not be held responsible for any damage to the user that may result from accidents or any other reasons during operation of the user's unit according to this document.

The NBF-2 does not validate the NMEA data it receives in any way. Neither the NMEA sentence checksum, nor the data contained within the NMEA sentence is validated. Therefore, the electronic device(s) supplying the NBF-2 with NMEA data retain(s) the sole responsibility for the NMEA data's validity.

Foreword

Actisense™ recognises that instructions are often skipped, so we have aimed to write this document in an informative, yet direct manner that will aid the user. We have tried to cover all the points a typical user may need to know. Please read all sections before installing and using the **Actisense™** NMEA Buffer product and any related software programs.

Introduction

The **Actisense™** NMEA 0183 Buffer (NBF-2) product was developed to solve a common problem: wanting to share the NMEA information from an NMEA device with more than two other NMEA instruments. Most NMEA output's (e.g. GPS) can only drive 1 or 2 NMEA devices, any more and the signal becomes degraded and corruption of the NMEA data occurs.

The **Actisense™** NMEA Buffer solves all NMEA buffering problems by allowing distributed buffering of one NMEA instrument's data output to a large number of other NMEA device inputs, and if required, even a PC's RS232 port.

Utilising fourteen years of experience in the marine industry in creating market leading depth sounders and other NMEA products, **Actisense™** recognised the need to produce a full galvanic Opto-isolated, dependable NMEA buffering solution that meets, and indeed surpasses, all of the NMEA 0183 requirements.

Full information on the complete **Actisense™** product range can be found on the **Actisense™ website**.

NMEA 0183 Introduction

Designed over 20 years ago, the NMEA 0183 standard has slowly become the common method by which marine electronics devices talk to one another. The standard specifies both the electrical connections that make up an NMEA system and the format of the data sentences that carry the NMEA information.

The NMEA 0183 standard is a purely digital data transmission scheme, using '1's and '0's in a binary format, to communicate a digital representation of the required information (depth, speed etc.) to connected instruments.

Electrical specifications

The latest specifications for NMEA 0183 (version 2 onwards) are similar to the RS422 standard. They use +5v and 0v signalling, which is low voltage and can be interfaced to computer equipment (with an **Actisense™ Opto-isolated adapter cable**). In older equipment (version 1) however, voltage levels could be much greater (up to +/- 15v) as the original specification used 12-15 volt +/- signalling, which is similar to the standard RS232 computer serial communication ports.

The NMEA 0183 specification also requires that all receiving equipment must be Opto-isolated; this Opto-isolation requirement reduces the chances of interference and removes the problem of ground loop effects.

Technical features

The NMEA 0183 input is a galvanically opto-isolated differential input to fully comply with the NMEA 0183 standard specification. This allows the input to work correctly with long cable runs and in a noisy environment. Typical operating voltage is 2.0v to 15.0v. The unit can withstand +/- 35v continuously, and +/- 40v transients. The Opto-isolator can protect any upstream equipment (chart plotter, laptop PC, radar etc.) from up to 2500v of common mode voltage difference.

Removes all problematic ground loops between the NMEA device connected to the NBF-2 input port, and all the NMEA devices connected to the output ports.

The NBF-2 is equipped with 6 ISO-Drive outputs. **ISO-Drive output technology** creates a driver, unique to Actisense, that is isolated to 1500 volts. ISO-Drive creates a completely floating talker output, making safe connection to a PC an easy task.

The output automatically changes between differential and single ended drive depending upon the type of instrument it is connected to. The ISO-Drive output is fully compliant with the NMEA 0183 standard specification and is also compatible with RS232 signal levels.

Wide battery input voltage range to offer maximum compatibility, the NBF-2 can operate from a battery supply anywhere between 8 and 45 volts.

Very low power consumption that is typically 43mA with no load and 100mA with all 6 outputs maximally loaded (on a 12 volt system). This will reduce to 25mA and 50mA respectively on 24 volt systems.

Very tough Polycarbonate case is certified to IP66 (classified as "totally protected against dust and protection against low pressure jets of water from all directions"). Being Polycarbonate, it is also incredibly strong, offering a wide temperature range and superior protection to the electronics inside.

The IP66 rating of the case is only limited by the sealing gasket strip, which can be enhanced by applying a suitable non-acid based marine sealant to the gasket after wiring and testing. This will allow use of the unit in areas where salt spray could enter, accidental immersion may occur, or in environments where maximum long-term reliability is paramount.

Robust Nylon grommets are certified to IP68 (classified as immersible for long periods without water ingress). Note that to achieve this level of water integrity all grommets must be occupied by round-section cables.

Large range of possible cable diameters of between 4.5 mm and 10 mm, single or multi-pair wire types can be easily accepted.

Connecting devices together

The basics

NMEA data is transmitted from an information source such as GPS, depth sounder, gyro compass etc. These data sending devices are called “**Talkers**”.

Equipment receiving this information such as a chart-plotter, radar or NMEA display is called a “**Listener**”.

Unfortunately, only one Talker can be connected on to a single NMEA 0183 system at any one time. Two or more Talkers are simply not possible because they are not synchronised to each other, and will attempt to ‘talk’ at the same time (over each other), resulting in corruption of the NMEA data, and potentially in disaster if valuable data such as navigation information is lost or corrupted so that it is incorrect and/or misleading.

This fundamental problem with the NMEA system can be easily overcome, and multiple Talkers connected together, using the **Actisense™** NMEA Data Multiplexer “NDC” series of instruments. If the required system has multiple NMEA Talker device of the **same** type (e.g. two GPS units), the highest priority device can be automatically switched using the **Actisense™** Autoswitch (NSW-1).

Please visit the [Actisense™ website](#) for full details on these and other **Actisense™** products.

The output drive capability of many instruments means that often their NMEA outputs can only drive one or two Listeners. In this case, the output of the Talker can be boosted to ‘talk’ to six listeners simultaneously using the **Actisense™** NMEA Buffer.

The NMEA signals

The NMEA 0183 system v2.0 and later uses a “differential” signalling scheme, whereby two wires are used to transmit the NMEA data. These connections will be labelled as either NMEA “**A**” and “**B**” or NMEA “**+**” and “**-**” respectively, depending on the instrument and manufacturer.

When connecting between different manufacturers, there can be some confusion, but it is simple and easy to remember: NMEA “**A**” connects to NMEA “**+**” and NMEA “**B**” connects to NMEA “**-**”.

The different NMEA standards

The NMEA 0183 specification has slowly evolved over the years, so connecting one device to another is not always a straight forward matter. The earlier versions of NMEA 0183 (before v2.0, as detailed above), used slightly different connection methods and signal levels: the instruments had just one “NMEA” data line (‘**Tx**’ or ‘**Out**’), and used the ground as the other line - similar to the way a computer serial port works.

This connection method is referred to as “single ended” instead of the “differential” method used by NMEA 0183 v2.0 devices.

The data format is largely the same between both systems, with v2.0 adding some extra sentence strings, and removing older (redundant) sentence strings from the specification. The situation is further complicated, as many manufacturers still use the old (“single ended”) method of connection because it is cheaper to implement.

So how can an older type NMEA device be connected to a newer type device?

Care is needed – it is possible to damage or overload the output of a newer differential device if it is incorrectly connected to an older device. This is because the older devices used ground as the return, whereas the newer devices actually drive the NMEA “**-/B**” line between 5v and 0v. Thus, connecting this output to ground will result in high currents being drawn by the driver instrument, resulting in potential overheating and damage to the driver circuits.

To connect a new type differential device to an old type single-ended system, connect the NMEA “**+/A**” output from the differential driver to the single-ended NMEA “**Rx**” or “**In**” input of the device. Leave the NMEA “**-/B**” output floating. Connect the ground line of the differential output device to the ground of the single-ended device. This provides the required data signal return current path.

To connect an old type single-ended device to a new type differential device, connect the NMEA “**Tx**” or “**Out**” output from the single-ended driver to the differential NMEA “**+/A**” input of the device. Connect the ground line of the single-ended output device to the NMEA “**-/B**” input of the differential device. This provides the data signal return current path. If the NMEA “**-/B**” input is left floating, then data corruption / errors may occur.

The Actisense NBF-2 is equipped with ISO-Drive outputs which removes all of these problems. Because the ISO-Drive output “floats”, this means that it will automatically adjust to the voltage of the line it is connected to. Thus, it simplifies installation work, as you no longer need to check on the type of input used on the equipment that the NBF-2 is connected to. You can connect the “**B/-**” connection of the NBF-2 to ground or to a differential “**B/-**” input without worry - the voltage levels will simply adjust themselves to be correct.

Please refer to the [Output Connections](#) section for example of these connection methods.

Connections

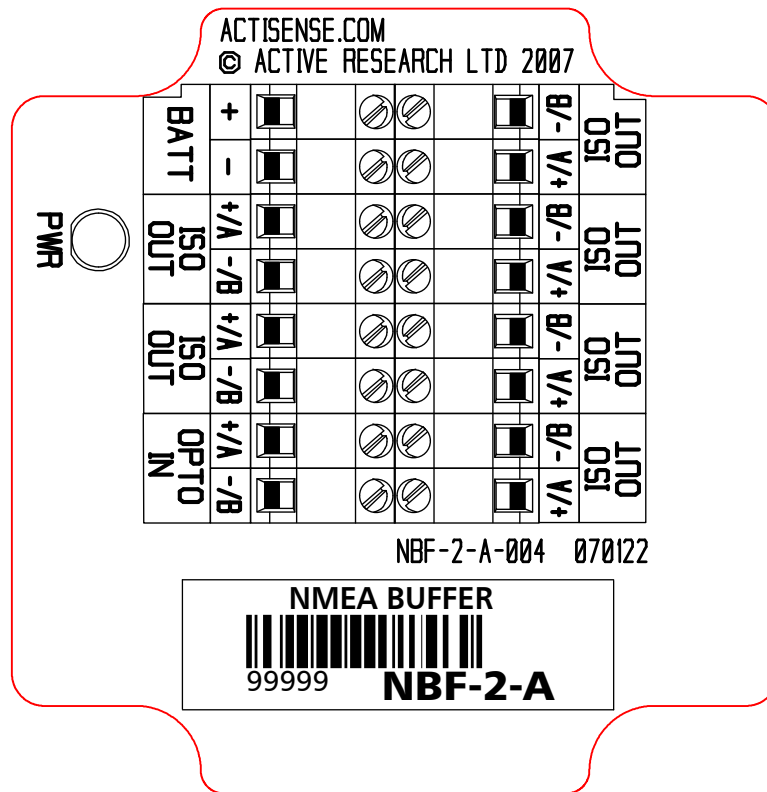

Figure 1 – All external connections

The NMEA Buffer (NBF-2) has screw-terminal “Phoenix” type external connections for: -

1. An NMEA 0183 “Listener” port
The NMEA 0183 input is of the differential opto-isolated type and uses the unique **Actisense™** low current drain circuitry (2mA @ 2.0v) to conform in full with the NMEA 0183 marine electronic device network communication standard, and is flexible enough to interface to most full and partially compliant devices.
2. Six ISO-Drive “Talker” ports
Each output comprises of two connections: ‘+/A’ and ‘-/B’, and conforms in full to the NMEA 0183 standard, and can be connected safely to NMEA 0183 v1,2,3,HS RS-232, RS-422 and RS-485 type listeners.
3. Battery supply input.

Note:

1. To complete the NMEA 0183 standard all device interconnection NMEA cables used should meet the two-conductor, shielded, twisted pair configuration specification. The shield connection of these wires should be connected at the instrument end only to prevent ground loops.
2. Refer to the **Specifications** section for the full details on input/output specifications.
3. If the laptop / PC to be used with the NBF-2 does not have an RS232 serial port available, the **Actisense™ USG-1** USB to Serial Gateway and the **USB-1** USB to RS232 adapter cable have been tried and tested to provide a compatible communications port. Please visit the **Actisense™ website** for full details on this, and other **Actisense™** products.
4. Higher quality cable will naturally yield higher performance / higher Signal-to-Noise Ratio (SNR).

Input Connections

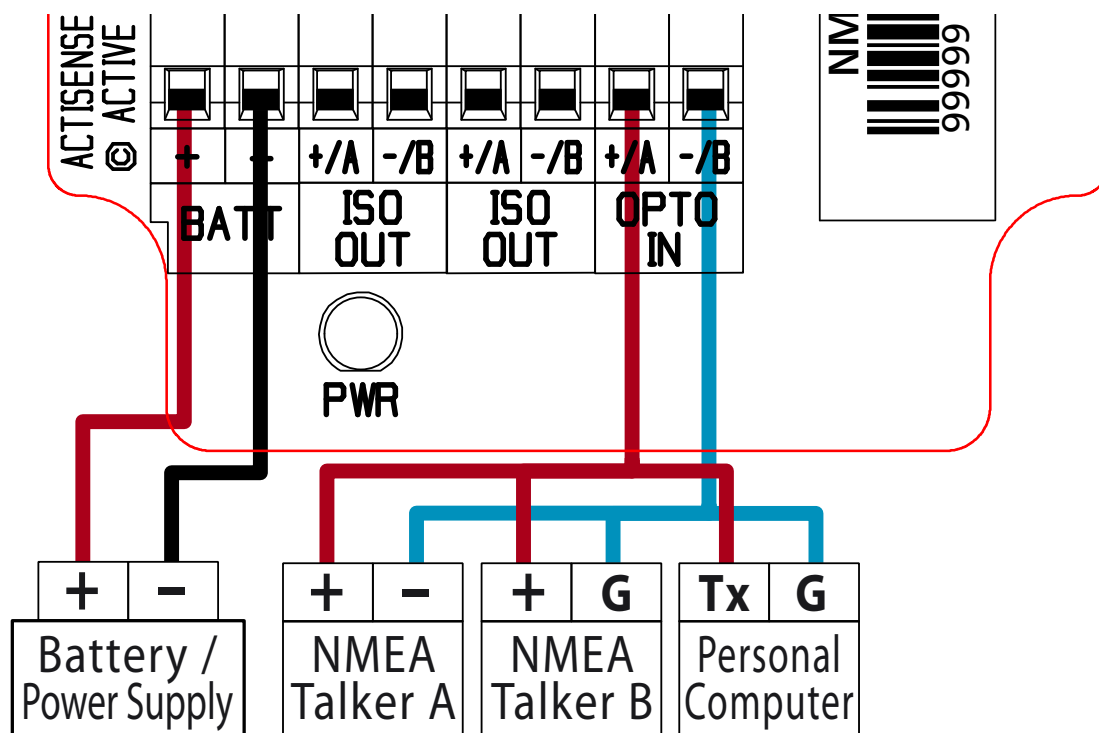

Figure 2 – Input connections

NMEA 0183 Input

The NMEA 0183 differential opto-isolated input is designed to handle a variety of NMEA 0183 talker specifications. Please determine (from device manufacturer's information) if the device required to be connected to the **Actisense™** NBF-2 conforms in full to the NMEA 0183 network communication standard. If it does not, the flexible **Actisense™** NBF-2 inputs should still be capable of interfacing with the device, though this is not guaranteed.

The diagram (figure 2) above shows a typical installation with both fully compliant NMEA devices with differential outputs, and non-differential devices that output NMEA using the ground line as the "NMEA -" line.

Please note that **only one NMEA device** can be connected to "NMEA IN" at any one time.

NMEA Talker device A: This device conforms in full to the NMEA 0183 standard and shares the same connection ID's as the **Actisense™** NBF, so connection is a simple matter of matching ID's (refer to figure 2).

NMEA Talker device B: This is a single ended (non-differential) device and does not conform completely to the NMEA 0183 standard. However, by connecting '+' to '+/A' and its 'G/Ground' to the NBF "-/B", the NBF should be able to receive the NMEA data correctly.

Personal Computer: A PC's RS232 output may be directly connected to the NBF-2. This allows a PC to drive many NMEA instruments from its RS232 port without risk of damage or overload, and creates isolation from the PC ground. Simply connect the PC's "Tx" pin (Pin 3 on 9-pin D-type connector) to the NBF's "+/A" and its "Ground" (Pin 5 on D-type) to the "-/B".

Connecting to the battery supply

The **Actisense™** NBF-2 should be wired to the vessel's battery supply in the most direct manner possible, to minimize interference from other electronic devices. The cable used should be of sufficient gauge to handle the power requirements of the **Actisense™** NBF-2 (refer to the **Specifications** sections).

Note:

1. Wire colours are for guidance only.

Output Connections

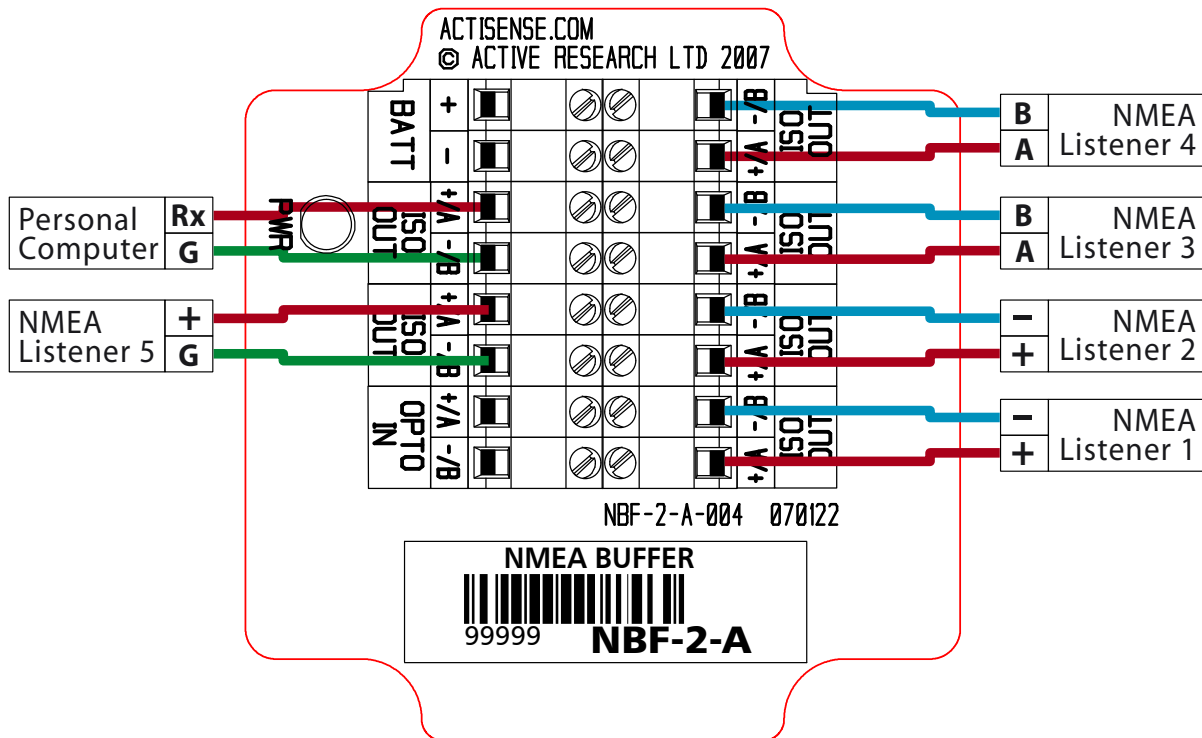

Figure 3 – Output connections

NMEA 0183 / RS422 Outputs

The NMEA 0183 / RS422 buffered outputs are capable of driving more than 10 fully NMEA 0183 compliant listening devices each. In practice, however, it is better to connect just one NMEA listener per output to maintain the isolation between each output. **Figure 3 shows one possible configuration of this preferred connection, using a range of typical listeners that may be encountered.**

NMEA Listener devices 1, 2, 3 and 4: These devices conform in full to the NMEA 0183 standard and their connection ID's match that of the NBF-2. Simply connect like for like (“+” to “+”, “A” to “A” etc.). Examples of both listener labelling types are shown.

NMEA Listener device 5: This device does not conform in full to the NMEA 0183 standard and is a “single-ended device”. **Connection of single-ended devices to a differential output used to be done with caution, but the NBF-2 now makes this risk free.**

Simply connect devices input, (which may be labelled ‘+’ or ‘Rx’) to the NBF ‘+/A’, and its ‘G/Ground’ to the the NBF ‘-/B’.

The listener device should now be able to receive the NMEA data correctly. This is not guaranteed, though, as the instrument may have been designed to require more than the 5v signal of the NBF-2 drive output.

In practice, this is rare, as most equipment is designed to work well below this voltage level.

Personal Computer: The NBF-2 ISO-Drive outputs are compatible with most personal computer RS232 port inputs. Connect PCs ‘Rx’ (Pin 2 on a standard 9-Pin D-type) to NBFs ‘+/A’ and its ‘G/Ground’ (Pin 5 on D-type) to the NBFs ‘-/B’.

Note: The PC will “see” a single-ended signal swinging between plus and minus 5v. This is more than enough for most PC receiver chips, which will normally operate successfully down to +/-2v.

Note:

1. Wire colours are for guidance only.

Troubleshooting guide

This guide will concentrate on all relevant troubleshooting issues above simple cable connection faults. Therefore, the cables between the NBF-2 hardware and any other devices should be checked as a matter of course, before continuing with this guide.

Problem / Error condition	Required user response
<p>No data seen on NMEA instrument display</p>	<p>Ensure that correct polarity of the NMEA connections have been observed - NMEA connections are polarity sensitive.</p> <p>“+” and “A” connections should be wired to the NBF’s “+/A”.</p> <p>“-” and “B” connections should be wired to the NBF’s “-/B”.</p> <p>No damage should be caused if the polarity is reversed, but no NMEA data will be seen on the receiving instrument.</p>
<p>No data seen on PC display</p>	<p>Ensure that the PC software is selecting the correct PC Comms port number and baud rate.</p> <p>As a diagnostic, you can use the standard Windows “HyperTerminal” utility to receive NMEA data. By setting the input comms port to the one the NMEA NBF-2 is connected to, the baud rate to that required (4800 normally), no parity, 1 stop bit, 8 data bits and no flow control, the received NMEA text data from the NBF-2 will be shown on the PC screen.</p>

Table 1 – Troubleshooting guide

Specifications

Parameter	Conditions / Note	Min.	Max.	Unit
Supply				
Supply voltage (note 1)		8	45	V
Supply current no-load / full load (note 2,3)	Supply voltage = 12v	43	100	mA
	Supply voltage = 24v	25	50	mA
OPTO Isolated Flexible Input				
Input voltage between +/-	Logical '1' / stop bit	-15.0	0.5	V
	Logical '0' / start bit	4.0	15.0	V
Input current	Maximum is under +35v overload condition, min @2.0v input level	1.6	9.0	mA
Differential input voltage	Minimum level for data detection	1.8	2.0	V
Galvanic isolation	Between input and ground		2500	V
ISO-Drive Flexible Output (RS-422, RS-485 and RS-232 compatible)				
Output voltage between ISO Out +/-A and ISO Out +/-B (under no load)	Logical '1' / stop bit	-4.8	-5.2	V
	Logical '0' / start bit	4.8	5.2	V
Output current (note 2,3)	At maximum load, drive voltage reduces to approx 2.7v	-	27	mA
Output short circuit current (note 4)		50	55	mA
Galvanic isolation	Between output and ground		1500	V
Other parameters				
Baud rate			115.2	Kbit/sec
Data propagation delay (typical)		1.7	2.1	us

General				
Ambient temperature		-20	+70	°C

Table 2 – NBF-2 specifications

All specifications are taken with reference to an ambient temperature (T_A) of +25°C.

Note:

1. Continuous supply voltage. The PSU used on the NBF-2 is a high specification switch-mode regulator, which can operate for short periods at up to 80v, allowing the unit to easily pass the "SAE J1113" transient test, where a transient impulse peaking at 80v is applied.
2. Current consumption measured under no-load and full-load conditions
3. "Full Load" is defined on a 100 ohm loads on each of the six ISO-Drive outputs, resulting in a net output current of approximately to 162mA to all outputs.
4. Short circuit may be applied indefinitely. The ISO-Drive output may be short-circuited directly to a 30 volt battery supply without damage. A maximum current of 50mA will flow due to "polyfuse" auto-resetting fuse technology being used in each output.

Company Information

Active Research Limited
5, Wessex Trade Centre
Ringwood Road
Poole
Dorset
UK
BH12 3PF

Telephone: 01202 746682 (International : +44 1202 746682)
Fax: 01202 746683 (International : +44 1202 746683)

Actisense™ on the Web: For advice, support and product details

E-mail: support@actisense.com
Website: www.actisense.com

Active Research on the Web: For specialist consultancy and customisation

E-mail: support@activer.com
Website: www.activer.com

