

ComNav[®]

marine ltd

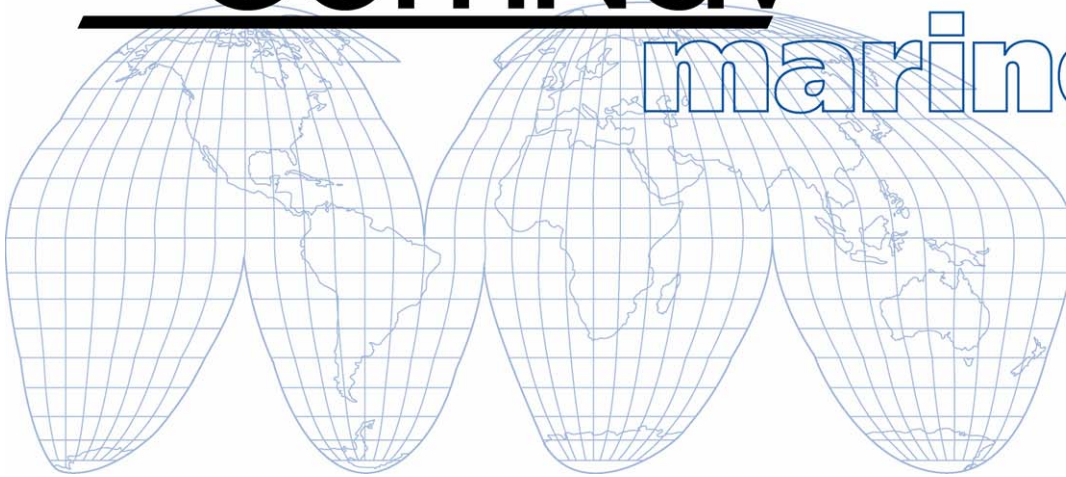

Navigator G2 *GPS Compass Display*

Installation & Operation Manual



ISO 9001



PN 29010081

www.busse-yachtshop.de | info@busse-yachtshop.de

Welcome

Congratulations on your purchase of ComNav Marine's Navigator G2 GPS Compass Display! At ComNav, we are proud of our prominence as a leader in the design and manufacture of marine autopilot systems. Our dedication to performance and reliability will ensure your satisfaction with the Navigator G2.

ComNav Marine Ltd.

Warranty Notice

Prior to the installation and/or operation of the equipment, ensure that you read, understand, and accept the conditions of the warranties as detailed in the **Warranty Information** section of this manual.

General Notice

This document, ComNav part number 29010081 Version 1 Revision 1, is the approved Installation and Operation Manual for use with Navigator G2 GPS Compass Display. Where versions of this manual exist in other languages, the English version shall be considered authoritative.

Document History

Revision	Date	By	Description
0R9	7-3-2008	G	Initial release from eMotion
1R0	7-3-2008	J	First release
1R1	31-3-2008	J	The system only works on 12 VDC system

Table of Contents

Welcome	1
Document History	2
Table of Contents	3
List of Figures	5
List of Tables	5
Overview of the Navigator G2	9
Vector Series GPS Compass	10
Display Head	10
Distribution Unit	11
About this Manual	12
Typefaces, Common Phrases & Terms	12
Manual Format	12
Installation	15
Technical Requirements	15
<i>Caution</i>	15
<i>Power Supply</i>	15
<i>Special Tools</i>	15
Electrical Connections	16
<i>Connector Termination</i>	16
<i>Terminal Strip Labels</i>	18
<i>Vector G2 Terminals</i>	19
<i>Display Head Terminals (#1 and #2)</i>	21
<i>NMEA Output Terminal</i>	22
<i>Ship Power Bus Terminal</i>	23
Post Check	23
Power Up Test	23
Basic Operation	27
Power On/Off	27
Display Controls	28
<i>Color Display Backlight and Day/Night Adjustment</i>	28
<i>Monochrome Display Contrast and Backlight Adjustment</i>	29
Normal Usage	30
<i>Display Pages</i>	31
<i>Information Pages</i>	33
<i>Parameter Setup Pages</i>	37
Care & Maintenance	43
Cleaning and Appearance	43
Protection of Wires and Cabling	43
Periodic Checks	43
Fuse Replacement	43
Appendix 1	47
Troubleshooting	47

Appendix 248
Wiring Reference for ComNav Standard Cables _____ 48

Appendix 351
Wiring Termination in the Distribution Unit _____ 51

Appendix 453
General Specifications _____ 53

Warranty Information57

User Notes62

List of Figures

Figure 1 – Vector G2 System Connections	9
Figure 2 – Vector G2 GPS Compass	10
Figure 3 - Navigator G2 Display Head	10
Figure 4 - Distribution Unit	11
Figure 5 – Distribution Unit Connector Blocks.....	16
Figure 6 - Terminal Connection - Step 1	17
Figure 7 - Terminal Connection - Step 2	17
Figure 8 - Terminal Connection Silk Screen Labels.....	18
Figure 9 – Vector G2 Power Connection - Always On or Switched.....	20
Figure 10 - Ship Power Connection	23
Figure 11 – Introductory Screen.....	27
Figure 12 - Color Control Head Backlight and Day/Night Adjust	28
Figure 13 - Monochrome Display Head Contrast and Backlight Adjust.....	29
Figure 14 - Navigator G2 Display Head Displays and Buttons.....	30
Figure 15 - Graphical Navigation Page Description	31
Figure 16 - Text Navigation Page Description.....	32
Figure 17 - Position Navigation Page Description.....	32
Figure 18 - Heading Information Page Description	34
Figure 19 - GPS Status Information Page Description.....	35
Figure 20 - GPS Satellite Information Page Description	36
Figure 21 - Parameter Setup Page - Button Descriptions	37
Figure 22 - NMEA Message Rate Page	38
Figure 23 - Binary/Differential Message Rate Page.....	38
Figure 24 - Smoothing Filters and Aids Page.....	39
Figure 25 - Pitch/Roll Page	39
Figure 26 - Cable Jacket Removal.....	51
Figure 27 - Cable Shield Removal	52
Figure 28 - Wire Insulation Removal.....	52
Figure 29 - Distribution Unit Dimensions.....	53

List of Tables

Table 1 – Vector G2 Wiring and Connections	19
Table 2 – Display Head Wiring and Connection.....	21
Table 3 – External NMEA, 1-pps, and Alarm Wiring	22
Table 4 – Navigation Page Fields Descriptions.....	33
Table 5 – Heading Information Page Fields Descriptions	34
Table 6 – GPS Status Fields Descriptions	35
Table 7 – Display Head General Specification.....	53
Table 8 – Distribution Unit General Specification.....	53
Table 9 – User Notes	62

Introduction

Overview of the Navigator G2

The Navigator G2 is designed to work with ComNav's Vector GPS compasses, and other NMEA devices.

Features included in the Navigator G2:

- Backlit graphical grey-scale LCD display shows navigation information
- Direct switch selection from various information pages
- Splash proof distribution box, with easy-to-install clamp terminal blocks for wiring
- Standard cable lengths: 25 feet cable to Display Head and 16 or 30 meters cable to Vector G2

The block diagram below shows how the Navigator G2 connects the Vector G2, G2 Display Head and Distribution Unit to other NMEA devices:

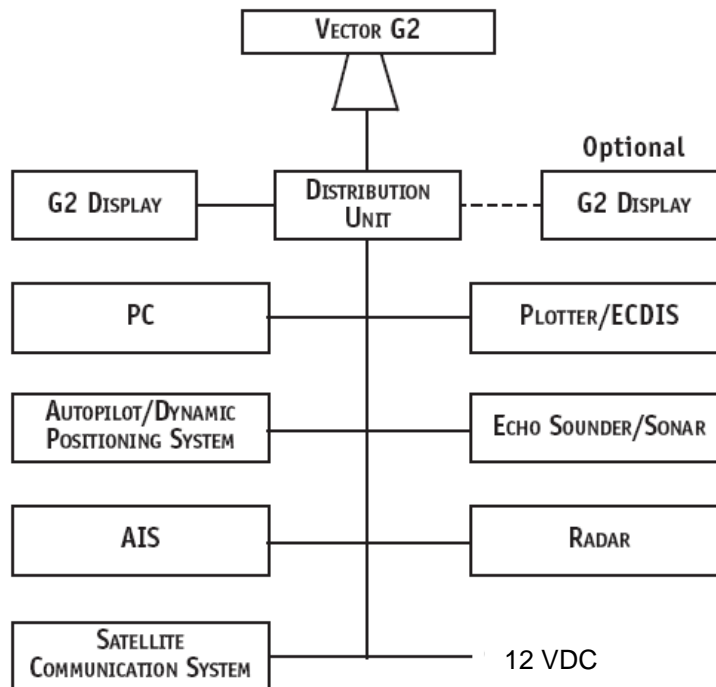

Figure 1 – Vector G2 System Connections

Vector Series GPS Compass

A Vector Series GPS Compass uses multiple GPS antennas and sensors to accurately sense vessel position, heading, pitch, and roll. A Vector Series compass communicates NMEA 0183 information out two data ports. Both RS232 and RS422 signal level outputs are supported.



Figure 2 – Vector G2 GPS Compass

Display Head

The Navigator G2 Display Head provides graphical and text information about the vessel position and attitude (speed, heading, turn rate). Two (2) G2 Display Heads can be driven from a single Distribution Unit.



Figure 3 - Navigator G2 Display Head

Distribution Unit

The G2 Distribution Unit provides a convenient location to terminate and distribute signals from the Vector Series GPS Compass. Using microprocessor based signal processing, the Distribution Unit receives NMEA data from the Vector Series GPS Compass, and communicates this information to multiple Control Heads and external NMEA devices

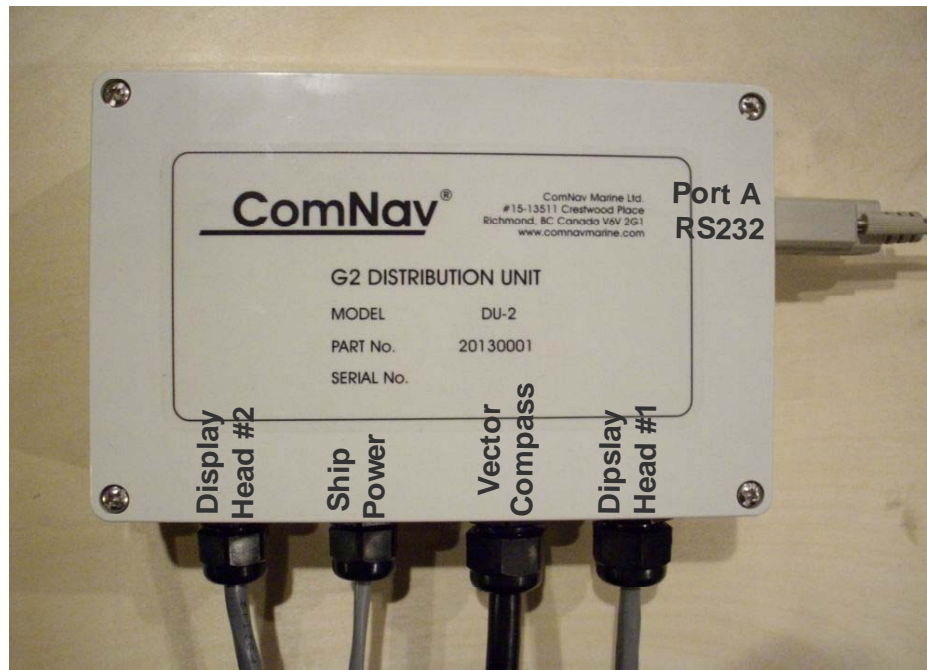

Figure 4 - Distribution Unit

About this Manual

This manual provides essential information for the safe and reliable operation of the ComNav Navigator G2 GPS Compass Display. You are urged to read this manual in its entirety before you use your Navigator G2 the first time, and to keep it handy until you become thoroughly familiar with the operation.

Typefaces, Common Phrases & Terms

Throughout this manual, you will see a number of different typefaces used, and several commonly-used words & phrases with very specific meanings, to describe concepts & actions that are fundamental to the operation of the autopilot. Please take a moment to become familiar with the following items:

Modes of Operation

Specific “modes of operation” are placed in bold uppercase lettering.

Example: **DISP** mode.

Button

Navigator G2 buttons and controls are placed in uppercase lettering.

Example: the FN button.

System Component

Specific System Components are capitalized.

Example: The Display Head.

LCD Display

Text that appears in the LCD display is in quotation marks.

press or momentary press

Press and release the indicated button.

press and hold

Press and hold the indicated button for a minimum of specified time interval.

This time delay is purposely programmed into the system’s response to some buttons, to prevent casual or accidental activation of the button function. For example, pressing the ON/OFF switch can turn off the G2 Series GPS Compass and Control Head. Depending on system configuration, other devices using the information will be no longer receive the information.

Manual Format

This manual has been formatted to be printed on both sides of the pages of the manual, and on standard Letter-sized paper (8.5” x 11”). If you have obtained this manual as a soft-copy, please note that it is in Adobe® Portable Document Format (“pdf”), and so may be viewed & printed with Adobe Reader®, or compatible pdf-format viewers.

When printing this manual with Reader, you should select “duplex printing” (or the equivalent term used by your printer’s software driver), in order to print it double-sided on the paper. If your printer does not have built-in duplexing capability, you can still print this manual double-sided by following the instructions that came with your printer for doing “hand duplexing”.

Installation

Installation

Technical Requirements

The following are the basic technical requirements that should be met before installation of the Navigator G2 on your vessel.

Caution

*Please refer to the **Warranty Information** this manual before proceeding with installation of the Navigator G2.*

Hazard warning!

CAUTION!

*Extreme caution is advised when using tools powered by alternating current (AC) from main AC supply circuits, regardless of whether the supply circuits are “indoor”, “outdoor”, “marine” or “industrial” rated. Water, especially sea water, is an **EXCELLENT** conductor of electricity, and can complete a path to AC Ground through a person’s body, causing injury or death, if a tool malfunctions or short-circuits.*

⇒ Battery powered tools are STRONGLY recommended ⇐

*If AC tools are used, they **MUST** be plugged into a circuit that is adequately protected against Ground Faults and other safety hazards, in accordance with local electrical codes.*

Power Supply

For reliable operation of your Navigator G2, your vessel’s power supply system must have an adequately-breakered, or fused, DC (direct current) power supply at a nominal voltage of either 12 volts. If the circuits are fused, a switch should also be provided. Ensure that adequate wire sizes are used to handle the expected maximum currents.

Special Tools

A slot screwdriver with a tip size of ~2.5 mm (0.1”) is required, for opening the spring loaded termination connectors inside the Distribution Unit.

Other general-purpose tools such as a portable drill, pliers, wire cutters, screwdrivers, wire, mounting bolts and wrenches will also be required.

Electrical Connections

The G2 Distribution Unit contains five (5) terminal blocks to connect signals from:

- Ship Power,
- Vector G2,
- Display Heads, and
- external NMEA devices.

Figure 5 shows the location of each block in a distribution unit.

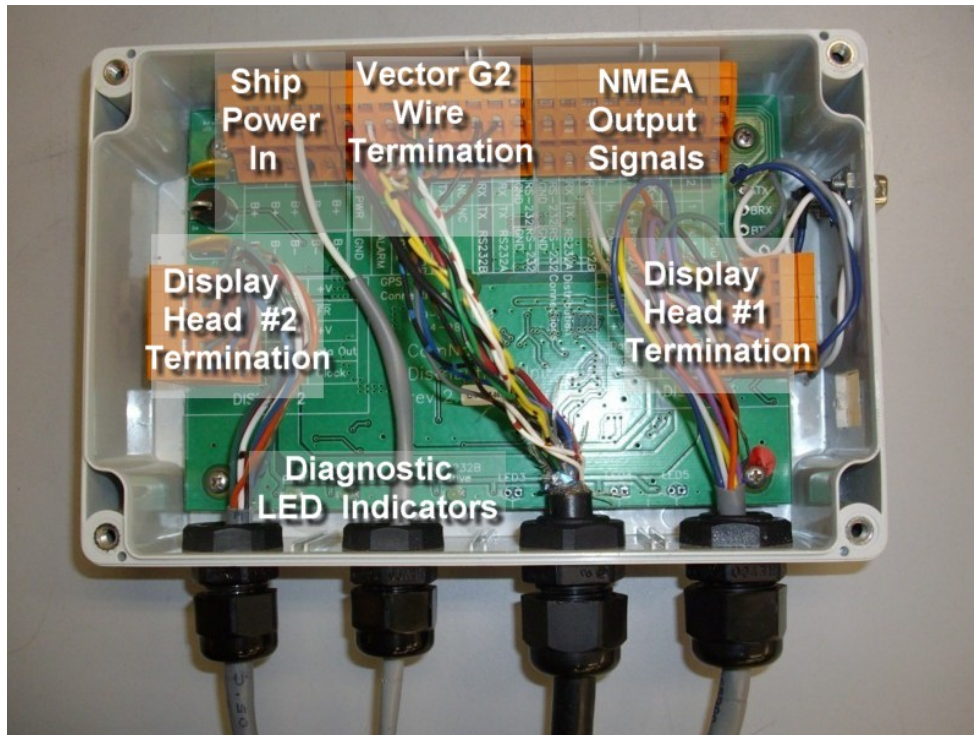

Figure 5 – Distribution Unit Connector Blocks

Connector Termination

The terminal blocks in the Distribution Unit allow all wiring from the GPS Compass, Display Head(s) and external devices to be conveniently and reliably terminated. Figure 6 and Figure 7 illustrate the proper termination procedure. To properly terminate a wire in the terminal blocks:

- Insert a narrow slotted screw driver into the opening above the terminal clamp
- Twist the screwdriver Up to open the terminal clamp
- Insert the wire all the way into the terminal clamp
- Release and remove the screwdriver
- Pull the wire to ensure the terminal clamp has securely gripped the wire.

It is easiest to connect wires on the lower tier before wires on the upper tier. This way the upper tier wires will not obstruct the terminal clamp for the lower tier.

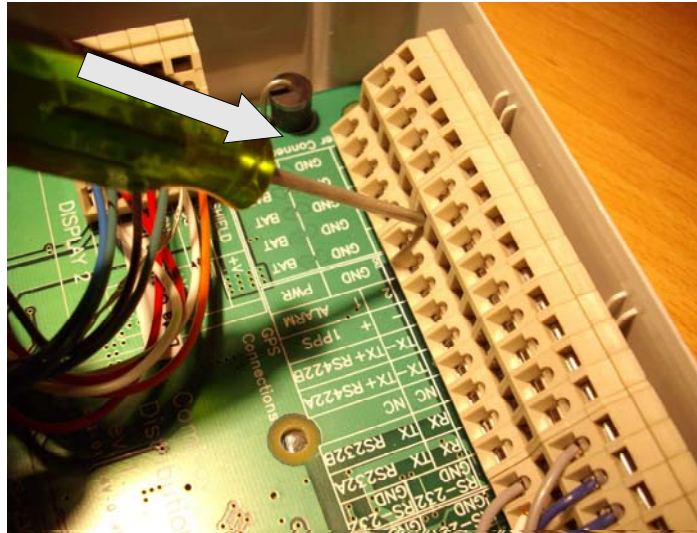

Figure 6 - Terminal Connection - Step 1

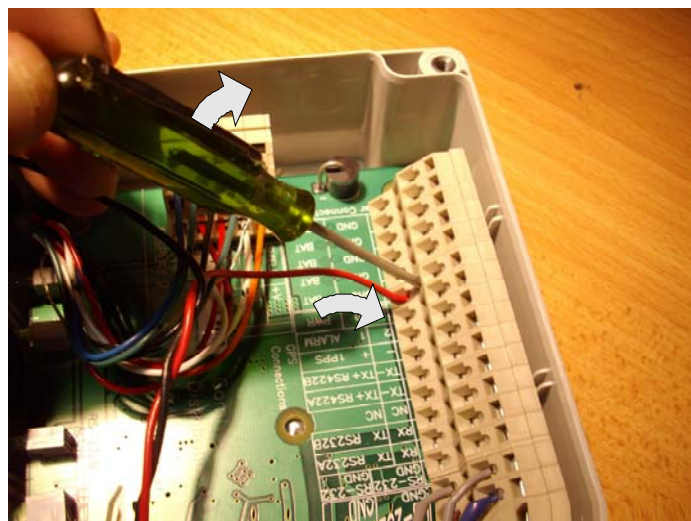

Figure 7 - Terminal Connection - Step 2

Terminal Strip Labels

The Distribution Unit uses two-tier, spring loaded terminal strips. The silk screen labels on the Printed Circuit board (PCB) identify terminal functions. Figure 8 below shows how the labels on the PCB map to the terminals on the connector blocks.

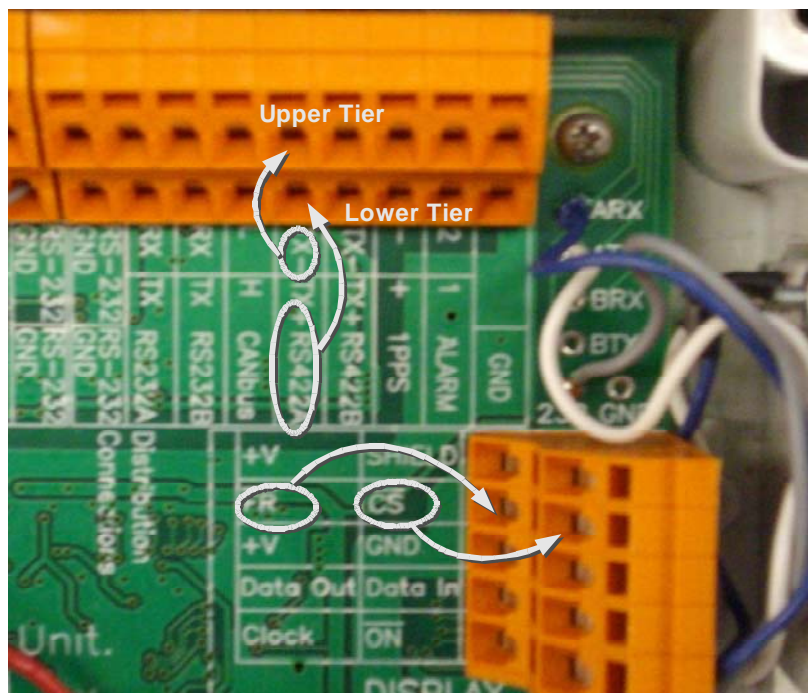

Figure 8 - Terminal Connection Silk Screen Labels

Vector G2 Terminals

Table 1 below lists the different signals and wire codes in the cable coming from a Vector G2 GPS Compass.

Table 1 – Vector G2 Wiring and Connections

Silkscreen Label	Color Codes 051-0063-004 051-0098-001	Color Codes 051-0157-002 051-0158-001	Description
	Bare Wire	Bare Wire	Drain for RF Shielding – Do Not Connect – Cut and Remove the exposed Bare Wire
	White	n/a	Do Not Connect
PWR	Red (18 AWG)	Red (18 AWG)	Power Input to Vector. Switched On and Off by the Display Head and Distribution Unit
GND	Black (18 AWG)	Black (18 AWG)	Power Ground
ALARM 1	n/a	White	Alarm 1
ALARM 2	n/a	White w/Red Stripe	Alarm 2
1PPS +	Orange	n/a	1 Pulse Per Second timing output (+ve signal)
1PPS -	Orange w/White Stripe	n/a	1 Pulse Per Second timing output (-ve signal)
RS422B TX+	Yellow	Yellow	GPS Port B Transmit (+ve signal)
RS422B TX-	Yellow w/White Stripe	Yellow w/Black Stripe	GPS Port B Transmit (-ve signal)
RS422A TX+	Green	Green	GPS Port A Transmit (+ve signal)
RS422A TX-	Green w/White Stripe	Black w/Green Stripe	GPS Port A Transmit (-ve signal)
NC			No signal connection
NC			No signal connection
RS232B TX	White	Brown	GPS Port B Transmit RS232
RS232B RX	Brown w/White Stripe	Black w/Brown Stripe	GPS Port B Receive RS232
RS232A TX	Blue	Blue	GPS Port A Transmit RS232
RS232A RX	Blue w/White Stripe	Black w/Blue Stripe	GPS Port A Receive RS232
RS232 GND	White w/Black Stripe	Grey	RS232 Signal Ground – NOTE: Isolated From Power Ground
RS232 GND			RS232 Signal Ground – Additional Connection Point - NOTE: Isolated From Power Ground

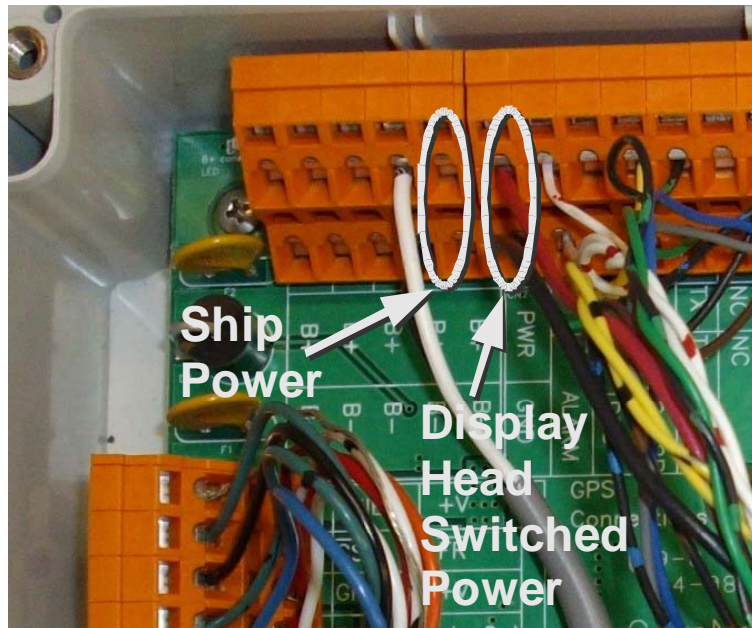

Figure 9 – Vector G2 Power Connection - Always On or Switched

The Vector G2 Power wires can be connected to two (2) different sets of terminals, depending on your vessel, and what other NMEA devices are receiving data from the Vector, as shown in figure 9.

- Always On – Connecting the Vector G2 power to the Ships power will mean the Vector will receive power as long as the Ship Power in to the Distribution Unit is On.
- Switched Power – Switched Power is turned On and Off by the Control Head Power button. If the Display Head is On, the Vector G2 will be powered as well. If the Display Head is Off, the Vector G2 will not be powered or transmitting data.

Display Head Terminals (#1 and #2)

Table 2 below lists the different signals in the Display Head cable which goes out to each Display Head.

Table 2 – Display Head Wiring and Connection

Silkscreen Label	Type 1 Wire Color Codes	Type 2 Wire Color Codes	Description
+V	Orange	Orange	Power to Display Head – Point 1
Shield	Bare Wire	Bare Wire	Drain for RF Shielding
FR	Brown	White w/Black Stripe	Data Communications Frame signal
CS	Green	Green	Data Communications Select Signal
+V	Red	Red	Power to Display Head – Point 2
GND	Black	Black	Power Ground
Data Out	Yellow	Red w/Black Stripe	Data Communications To the Display Head
Data In	Violet	Green w/Black Stripe	Data Communications From the Display Head
Clock	White	White	Data Communications Clock Signal
ON	Blue	Blue	Display Head Power On Button

NMEA Output Terminal

Table 3 below lists all of the NMEA and status signals located on the NMEA Terminal Strip. All external device connections must be made on this terminal strip.

Table 3 – External NMEA, 1-pps, and Alarm Wiring

Silkscreen Label	Description	Direction
RS232 GND	RS232 Signal Ground – Point 1 – NOTE: Isolated From Power Ground	
RS232 GND	RS232 Signal Ground – Point 2 – NOTE: Isolated From Power Ground	
RS232A TX	GPS Port A Transmit RS232	Output from Distribution Unit
RS232A RX	GPS Port A Receive RS232	Input to Distribution Unit
RS232B TX	GPS Port B Transmit RS232	Output from Distribution Unit
RS232B RX	GPS Port B Receive RS232	Input to Distribution Unit
CANBus L	NMEA2000 CAN bus port (Low signal)	
CANBus H	NMEA2000 CAN bus port (High signal)	
RS422A TX+	GPS Port A Transmit (+ve signal)	Output from Distribution Unit
RS422A TX-	GPS Port A Transmit (-ve signal)	Output from Distribution Unit
RS422B TX+	GPS Port B Transmit (+ve signal)	Output from Distribution Unit
RS422B TX-	GPS Port B Transmit (-ve signal)	Output from Distribution Unit
1PPS +	1 Pulse Per Second timing output (+ve signal)	Output from Distribution Unit
1PPS -	1 Pulse Per Second timing output (-ve signal)	Output from Distribution Unit
ALARM 1	GPS Alarm 1	Output from Distribution Unit
ALARM 2	GPS Alarm 2	Output from Distribution Unit
GND	Power Ground	
NC	No signal connection	

Ship Power Bus Terminal

Ship Power into the Distribution Unit must connect to the Power Bus block. The Distribution Unit protects the Vector and Display Head power from Ship Power over voltage and reverse voltage faults. It is important that the Vector and Display Heads receive their power input from the protected power connections on their connector block.

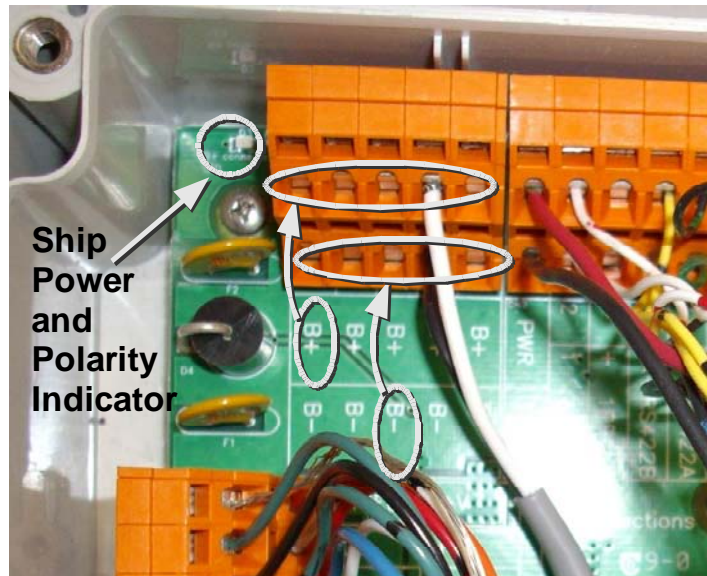

Figure 10 - Ship Power Connection

In figure 10, the top tier of terminals, on the Power Bus block, are electrically connected together on the Distribution Unit and be connected to the positive (B+) Ship Power wire.

The bottom tier of terminals, on the Power Bus block, are electrically connected together on the Distribution Unit and be connected to the negative (B-) Ship Power wire

The indicator LED will be GREEN if:

- Ship Power is applied, AND
- polarity (B+, B-) are correct.

If an over voltage or reverse voltage condition occurs on the Ship Power terminal, a thermally-resetting fuse will break. Once the Ship Power fault condition is corrected, it may take several minutes for the thermal fuse to reset.

Post Check

Before applying ship power, check the following:

- All wires are secure
- No frayed wire strands come out of the terminal blocks
- Cord grips are tight

Power Up Test

To power up the Distribution Unit and verify that it is functioning:

- Turn on Ship Power (B+ and B-).
- Verify GREEN Power

Operation

Basic Operation

This section describes the basic modes of operation of the G2 Display Head.

Power On/Off

To turn on ...

- Press Control Head On/Off Switch .
- Verify that the Distribution Unit Switched Power LED is ON.
- Verify that the Control Head LCD powers up.
- Verify that the Distribution RS232A and RS232 B Active LEDs begin to pulse.
- Verify that values begin to display on the Control Head as the GPS acquires satellites.



Figure 11 – Introductory Screen

To turn off ...

- Press and Hold Control Head ON/OFF Switch .
- The Control Head Power Down screen will appear and count until the Control Head and GPS Unit turns off.
- Releasing the ON/OFF before the Control Head has turned off will return to the last display page and continue normal operation.

Display Controls

Color Display Backlight and Day/Night Adjustment

The Color Display Head is able to change both the backlight level, and active color scheme. Colors can switch between:

- Day (Black on Blue background), and
- Night (Red on Black background).

The UP/DOWN Arrows buttons are used to increase the backlight level and change between Day and Night color schemes. Upon power up, the Display defaults to Day color scheme and a mid level backlight. Pressing the DOWN Arrow button will reduce the backlight level. Pressing the UP Arrow button will increase the backlight level. Once the lowest Day backlight level has been reached, pressing the DOWN Arrow button will switch to the brightest backlight level in the Night color scheme. Continuing to press the DOWN Arrow button will reduce the backlight level of the Night color scheme.

There are four (4) backlight levels for the Day color scheme and four (4) backlight levels for Night color scheme.

Figure 12 illustrates the how the backlight and Day/Night colors are adjusted.

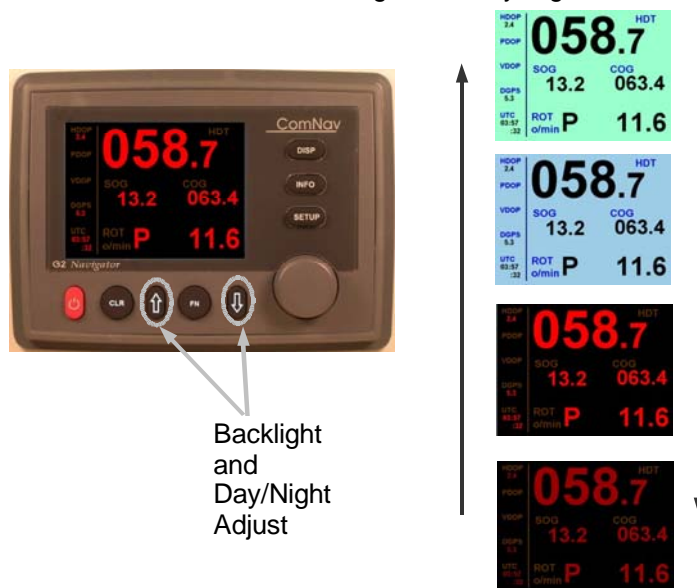

Figure 12 - Color Control Head Backlight and Day/Night Adjust

Monochrome Display Contrast and Backlight Adjustment

The Monochrome Display Head is able to change both the LCD contrast, and the backlight for the buttons. Contrast and backlight must be adjusted separately. See figure 13.

The UP/DOWN Arrows buttons are used to change the LCD Contrast level. The CLR/FN buttons are used to adjust the button backlight levels. There are eight (8) levels of Contrast adjustment and eight (8) levels of backlight adjustment.

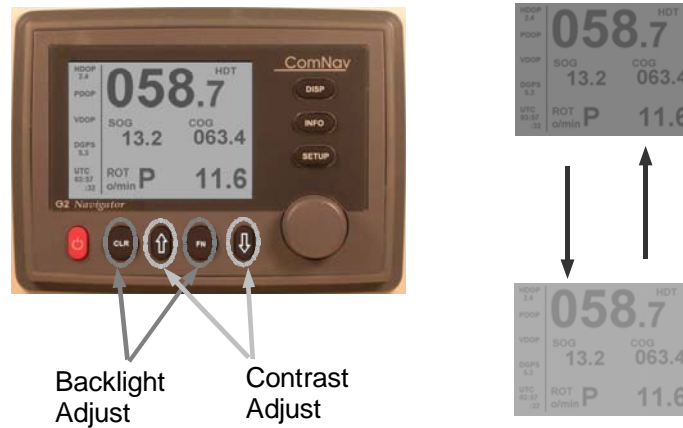

Figure 13 - Monochrome Display Head Contrast and Backlight Adjust

Normal Usage

The G2 Display Head provides graphical and text information about the vessel position and attitude (speed, heading, turn rate). Two (2) Display Heads can be driven from a single Distribution Unit.

The G2 display provides three different levels of display pages. The first level pages (DISP mode) shows information typically used during vessel operation including graphical and text displays of vessel operation. Pressing the DISP button repeatedly will cycle through the Display pages.

The second level pages (INFO mode) show more detailed operational parameters such as sensor smoothing constants, and GPS operational information (number of satellites, type of fix, etc). Pressing the INFO button repeatedly will cycle through the Display pages.

The third level pages (SETUP mode) allows you to change operating parameters in the Vector Series GPS compass. Operating parameters include:

- message rates for NMEA messages,
- message rates for binary message,
- sensor smoothing constants,
- sensor bias adjustments, and
- sensor filter aids.

Pressing the SETUP button repeatedly will cycle through a series of setup pages.

Figure 14 is the summary of buttons and their associated pages and functions.

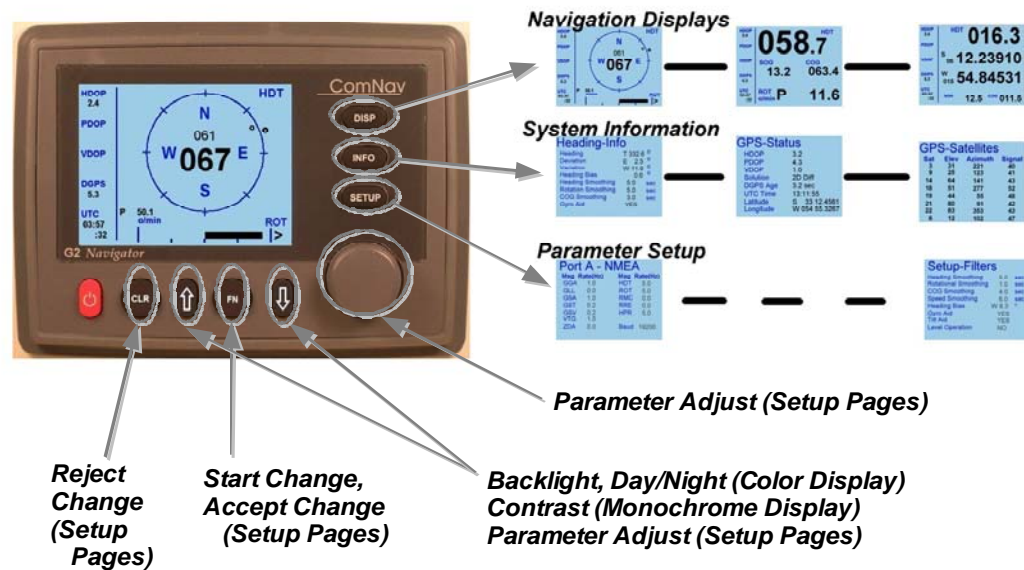

Figure 14 - Navigator G2 Display Head Displays and Buttons

A data value may not be available because a message containing the value is not transmitting, or GPS compass is not able to determine a value based on the satellites in view.

The following NMEA messages are recommended to display most value fields on the Control Head:

- Position – GGA or RMC
- Heading – HDT, HDM, or HDG
- Speed and Course – VTG or RMC
- Rate of Turn - ROT
- Satellite Information – GSA or GSV

Display Pages

There are three pages which can be selected by toggling the DISP button – Graphical, Text and Position pages. All pages show status information on the Left side of the screen.

The status information indicates the quality of the GPS data display. For example, the lower the DOP (Dilution of Precision), the better the GPS positional accuracy.

The Graphical Display page shows navigation information including a graphical Compass Ring display of vessel heading and course over ground.

The heading ball and COG ball are indicators of current heading and COG on the north-up compass ring. If the vessel is stopped, the COG ball will disappear as there is no course over ground for a still vessel. If current heading is not available, the heading will also disappear.

The Rate of Turn is displayed in degrees per minutes and shows in the bar at the bottom of the screen.

An example of Graphical display is given in Figure 15.

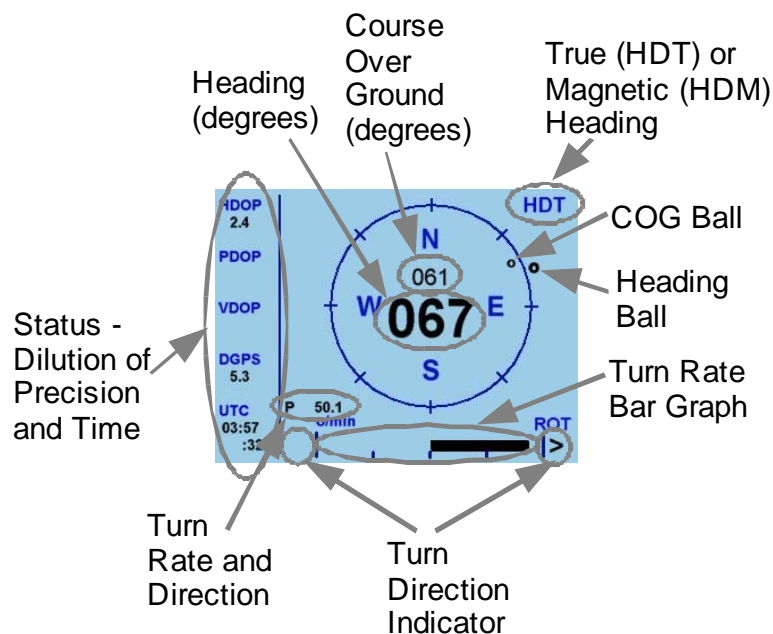

Figure 15 - Graphical Navigation Page Description

The Text Display shows general navigation information as text numbers. Heading and course over ground are both displayed in a large font text format. An example of Text display is given in Figure 16.

The Position Page shows navigation information including the GPS position fix. See Figure 17 for an example.

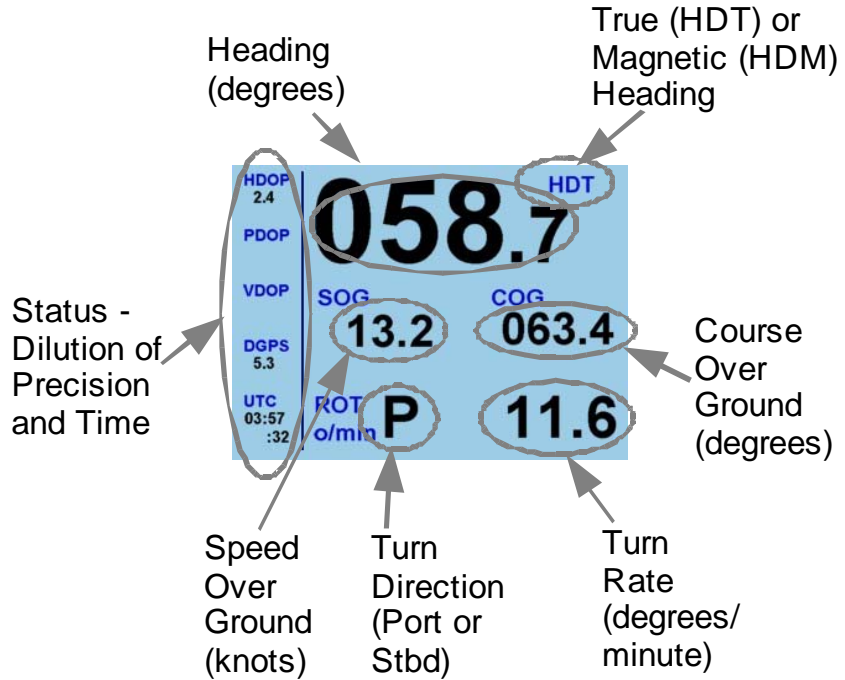

Figure 16 - Text Navigation Page Description

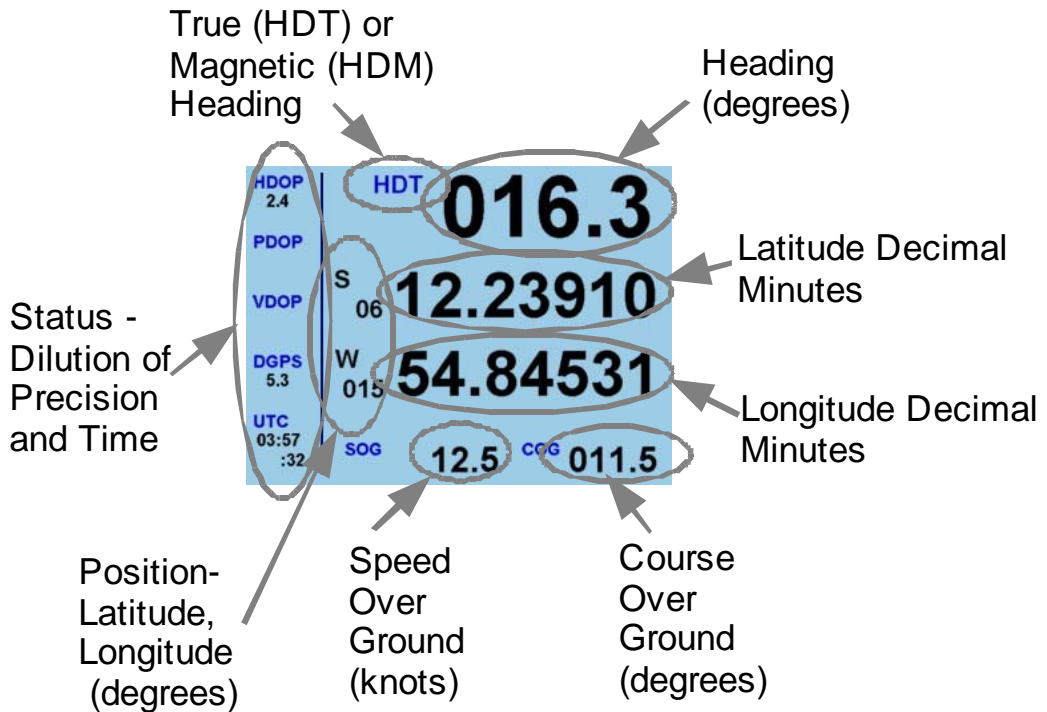

Figure 17 - Position Navigation Page Description

Table 4 gives a summary of information displayed on the Navigation pages and the NMEA sentences the information extracted from.

Table 4 – Navigation Page Fields Descriptions

Field	Description	NMEA Message Source
Heading	Heading in units of degrees. True (HDT) or Magnetic (HDM) depending on the NMEA sentences being received.	HDT, HDM, HDG
COG	Course Over Ground. Displayed in Units of degrees.	VTG, RMC
SOG	Speed Over Ground. Displayed in Units of knots.	VTG, RMC
ROT	Rate of Turn of the vessel. Displayed in Units degrees per minute.	ROT
Position	Latitude and Longitude of the vessel. Displayed as Degrees and Minutes.	GGA, GLL, RMC
PDOP	Position Dilution of Precision. A measure of the overall position accuracy.	GSA
HDOP	Horizontal Dilution of Precision. A measure of the horizontal position accuracy.	GGA, GSA
VDOP	Vertical Dilution of Precision. A measure of the vertical position accuracy.	GSA
DGPS	Indicate whether Differential Position sensing is Active, and the age of the DGPS information being used.	GGA
UTC Time	Universal Coordinated Time. Displayed as hours, minutes and seconds.	GGA, GLL, RMC, ZDA

Information Pages

There are three Information pages which can be selected by toggling the INFO button.

The Heading Information page shows detailed heading information including Magnetic Variation, Bias adjustment and Filter Smoothing.

Figure 18 shows an example of the Heading Information page. Table 5 summarizes the meaning of each field and where it comes from.

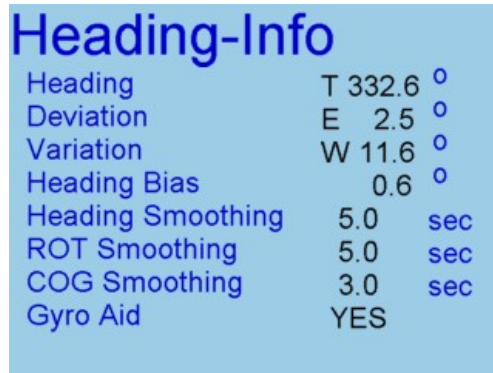

Figure 18 - Heading Information Page Description

Table 5 – Heading Information Page Fields Descriptions

Field	Description	NMEA Message Source
Heading	Heading angle in units of degrees. ‘T’ if True Heading. ‘M’ if Magnetic Heading.	HDT, HDM, HDG
Deviation	Heading Deviation in units of degrees. ‘E’ for East adjustment. ‘W’ for West adjustment.	HDG
Variation	Heading Variation in units of degrees. ‘E’ for East adjustment. ‘W’ for West adjustment.	RMC, HDG
Heading Bias	Heading Bias which is added, by the GPS compass, to the sensed heading. Typically used to adjust for mounting offset.	Property sentence
Heading Smoothing	Heading Smoothing Filter time constant in units of seconds.	Property sentence
ROT Smoothing	Rate of Turn Smoothing Filter time constant in units of seconds.	Property sentence
COG Smoothing	Course Over Ground Smoothing Filter time constant in units of seconds.	Property sentence
Gyro Aid	Status of whether the Gyro Aid filter is Active (YES) in the G2 Series Compass. Gyro Aid allows the compass to improve the sensed accuracy above what is possible with only GPS signals.	Property sentence

The GPS Status page displays detailed GPS information including:

- Dilution of Precision Values
- Number of Satellites in the solution and in view
- Type of Solution Fix
- Differential GPS Station and Age
- UTC Date and Time
- Latitude and Longitude

Figure 19 shows an example of the GPS Status page. Table 6 gives which NMEA sentences these information comes from.

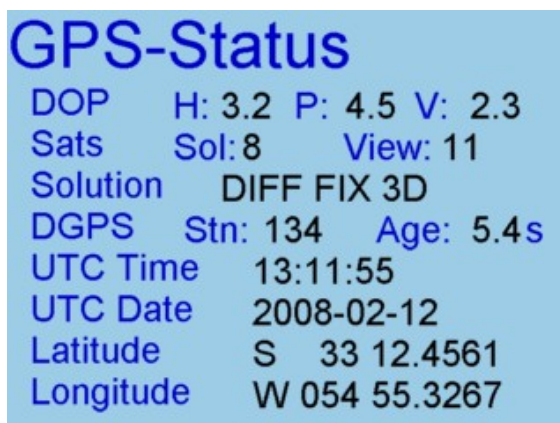

Figure 19 - GPS Status Information Page Description

Table 6 – GPS Status Page Fields Descriptions

Field	Description	NMEA Sentence Source
DOP	Dilution of precision. This line is a combination of PDOP, HDOP and VDOP. Sentences for each dilution can be found in Table 4 of the manual V1.0	GGA and GSA
Sats	2 sub-fields show the number of 1) satellites in solution; 2) satellites in view	1) GGA, GSA 2) GSV
Solution	Type of solution. It can be one of "no fix", "GPS fix" or "differential GPS fix". For GPS fix, dimension of the fix is also provided from GSA	GGA and GSA
DGPS	If differential fix is used, the DGPS station ID and data age.	GGA
UTC Time	Universal Coordinated Time in hh:mm:ss	GGA, GLL, RMC, ZDA
UTC Date	UTC date in year, month, and day	RMC, ZDA
Latitude	Latitude of the vessel	GGA, GLL, RMC
Longitude	Longitude of the vessel	GGA, GLL, RMC

The GPS Satellite page displays satellite position information for up to eight (8) satellites with strong signal levels. Satellites are displayed in ascending order using the Satellite ID number. Information includes:

- Satellite elevation above the horizon
- Azimuth angle relative to True North
- Signal strength

The information in this page comes from NMEA sentence GVS.

Figure 20 shows an example of the GPS Satellite Information page.

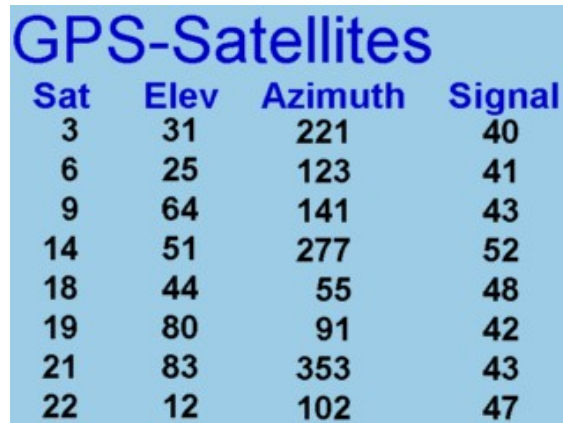

Sat	Elev	Azimuth	Signal
3	31	221	40
6	25	123	41
9	64	141	43
14	51	277	52
18	44	55	48
19	80	91	42
21	83	353	43
22	12	102	47

Figure 20 - GPS Satellite Information Page Description

Parameter Setup Pages

The SETUP pages allow you to change parameters within the G2 Vector GPS Compass. Parameters which can be changed include:

- Message Rates
- Smoothing Filter Time Constants
- Sensor Bias values
- Sensor Aid filters

To change a parameter:

- Select the correct SETUP page by toggling the SETUP button until the desired parameter appears,
- Select the parameter using the UP Arrow and DOWN Arrow buttons
- Start changing the parameter by pressing the FN button
- Change the parameter value by turning the DIAL knob Clockwise or Counter Clockwise
- Reject the change by pressing the CLR button, or
- Accept the parameter change by pressing the FN button

Figure 21 illustrates the above procedure.

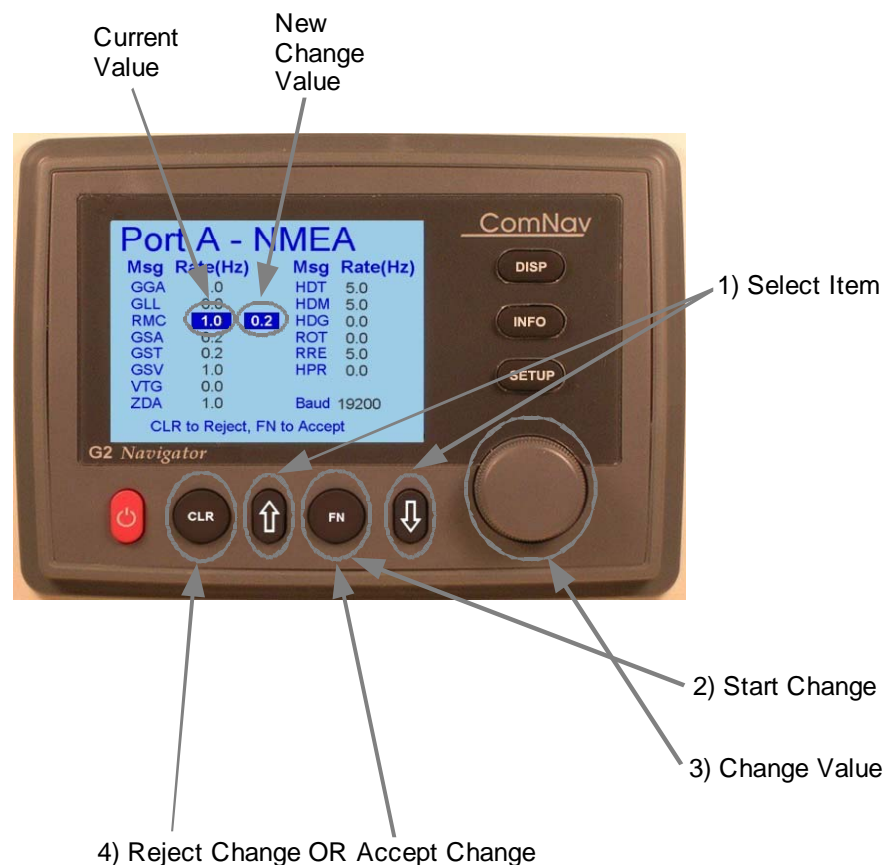

Figure 21 - Parameter Setup Page - Button Descriptions

The NMEA sentences and messages rates can be changed using the Port A or Port B NMEA message rate pages. This page lists each NMEA sentence which can be changed, as well as the current message rate.

You can only select a message rate permitted by the G2 Series compass for message you have selected.

- All messages can be sent at 1.0 Hz or one (1) message per second.
- All messages can be sent at 0.2 Hz or one (1) message every five (5) seconds.
- Certain messages can be transmitted at 5.0 Hz or five (5) messages per second.
- Certain messages can be sent at 10.0 Hz or ten (10) messages per second.
- A message rate of 0.0 Hz for any message means that the message is not being transmitted.

Figure 22 shows an example of the NMEA message rate page for Port A.

Port A - NMEA			
Msg	Rate(Hz)	Msg	Rate(Hz)
GGA	1.0	HDT	5.0
GLL	0.0	HDM	5.0
RMC	1.0	HDG	0.0
GSA	0.2	ROT	0.0
GST	0.2	RRE	5.0
GSV	1.0	HPR	0.0
VTG	0.0		
ZDA	1.0	Baud	19200

Arrows to Select, FN to Edit

Figure 22 - NMEA Message Rate Page

The Binary sentences and messages rates can be changed using the Port A or Port B Binary message rate pages. This page lists each Binary or Differential sentence which can be changed, as well as the current message rate.

Figure 23 shows an example of the Binary/Differential message rate page for Port A.

Port A -Bin/Diff			
Msg	Rate(Hz)	Msg	Rate(Hz)
1-Pos	1.0	97-Status	5.0
2-DOP	0.0	98-Alman	5.0
80-SBAS	1.0	99-Diag	0.0
93-WAAS	0.2		
94-UTC	0.2	INTLT	5.0
95-Ephm	1.0	RDI	0.0
96-Carrier	0.0	RTCM	OFF

Arrows to Select, FN to Edit

Figure 23 - Binary/Differential Message Rate Page

The Filter Smoothing and Sensor Aids page allows the GPS sensor filtering to be adjusted to match your vessel dynamics.

Figure 24 shows an example of the Filter and Aids page.



Figure 24 - Smoothing Filters and Aids Page

The Pitch/Roll page allows specific performance of the G2 Vector Pitch/Roll sensor to be configured. It also displays Firmware information about the Control Head and the Distribution Unit.

Figure 25 shows an example of the Pitch/Roll page.



Figure 25 - Pitch/Roll Page

Care & Maintenance

Care & Maintenance

The Navigator G2 GPS Compass Display has been designed to provide many years of reliable service. The following periodic care and maintenance tips will help to ensure the longevity of your GPS Compass Display.

Cleaning and Appearance

The Control Head should be carefully cleaned on a regular basis with a damp cloth and mild soap.

Do not use abrasive cleaners or chemicals.

The Control Head and Distribution Unit are designed to be weatherproof and splash resistant, but they should not be immersed in water for a prolonged period of time.

Environments exceeding a maximum temperature of 175° F (80° C) or below a minimum temperature of -20° F (-30° C) MUST BE AVOIDED.

Exposure to prolonged direct sunlight should be avoided in order to prevent damage to the electronics and housing, and UV-induced fading of the LCD.

Protection of Wires and Cabling

After installation, ensure that the system components are securely mounted and will not shake loose due to the vibrations that can be expected in a marine vessel.

Ensure that the cabling and wiring to all system components are well secured with clamps or alternative fasteners.

Many potential problems can be avoided by ensuring that cabling and wiring do not cause strain on the connectors.

Periodic Checks

There are no user-serviceable parts or adjustments inside the Navigator G2 enclosure. Should the unit become damaged in any way, return it to an authorized ComNav Dealer.

A few precautions will keep the unit in prime condition and result in years of trouble-free service:

- The Navigator G2 housing does not require any special maintenance other than an occasional cleaning.
- Avoid exposing the housing to solvents, acids, and bases as some of these may weaken the casing.
- Although the Display Head is watertight, it is not designed for submersion under water.
- The DU-2 is not designed water proof; please avoid direct exposure to water.

Fuse Replacement

There are no replaceable fuses used in the Navigator G2. The Distribution Unit is manufactured with two thermal-reset fuses. Should a fuse blow, turn off the ship power to the Distribution Unit and determine the cause. After a period of time, up to several minutes, the thermal fuse will reset and the Distribution Unit will function normally. The Ship Power LED DOES NOT indicate when a thermal fuse has blown. The Power LED is connected directly to the B+,B- terminals, before the thermal-reset fuse. If the thermal fuse had blown, switched power to the display will not turn on.

Appendices

Appendix 1

Troubleshooting

This section lists many of the common problems which you may encounter while installing and operating your Vector Series Navigator system. It also identifies potential causes and how to use the diagnostic indicators to narrow down the source of the problem.

Symptom	Possible Cause
Power LED Off	<ul style="list-style-type: none"> • Ship Power not connected • Ship Power Breaker OFF • Ship Power polarity (B+,B-) are reversed.
No Display Head Power	<ul style="list-style-type: none"> • GPS Switched Power is Off. Press the Display Head On/Off switch. Switch Power LED will light and Display Head will become active. • V+ or GND not wired correctly to Display Head Terminal
Blank LCD after power on	<ul style="list-style-type: none"> • Voltage is too low
No NMEA Messages Transmitted to External device	<ul style="list-style-type: none"> • GPS Switched Power is Off. Press the Display Head On/Off switch. Switch Power LED will light and Display Head will become active. • RS232 communications LEDs (Port A or Port B) DO NOT flash. No Vector data is being received. Check wiring from GPS Compass to Distribution Unit. Verify that Vector is configured to send messages on the desired Port. • RS232 communications LEDs (Port A or Port B) flash. Data is being received from the Vector. Check wiring from Distribution Unit to the external NMEA device.
No Values are being displayed.	<ul style="list-style-type: none"> • The GPS has not acquired enough satellites for a solution. It may take one minute or longer for the GPS to acquire enough satellites. • No NMEA messages are configured to transmit from the GPS on Port A. Check the Setup Page "Port A-NMEA". A message rate of "0.0" means that the message is not being transmitted. • RS232A TX connection from the GPS compass is not connected. Check the Indicator Light on the Distribution Unit.
Not all data Values are Displayed.	<ul style="list-style-type: none"> • The GPS has not acquired enough satellites for all Values. It may take one minute or longer for the GPS to acquire enough satellites to display all data Values. Normally, UTC Time is the first Value to be acquired and transmitted once the GPS is receiving satellite signals. • No NMEA message, containing this data value, is being transmitted from the GPS on Port A.
COG (Course Over Ground) ball is not displayed on the Navigation Graphics page	<ul style="list-style-type: none"> • SOG (Speed Over Ground) is too slow. When the vessel begins to move, the COG ball will be displayed. • No NMEA message being transmitted on Port A, which contains COG (also called Track Made Good). • RS232A TX connection from the GPS compass is not connected.

Appendix 2

Wiring Reference for ComNav Standard Cables

The drawing in the next page is a wiring reference with color code for ComNav standard cables for Vector and Display Head

**NAVIGATOR G2 DISTRIBUTION UNIT
PN20130001**

Navigator G2 Display
PN20130002 or PN20130003

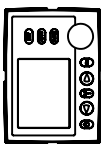

G2 Display cable PN31110048

5	SHIELD	+V:ORANGE
4	/FR:BROWN or WHITE/BLACK	/CS:GREEN
3	GND:BLACK	+V:RED
2	DI:VIOLET or GREEN/BLACK	DO:YELLOW or RED/BLACK
1	ON:BLUE	CL:WHITE

Power Supply In
12V DC

CN6	1-4	5		
1	2	3	4	5
1	2	3	4	5
1	2	3	4	5
1	2	3	4	5

Navigator G2 Display
PN20130002 or PN20130003

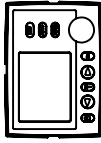

G2 Display cable PN31110048

5	SHIELD	+V:ORANGE
4	/FR:BROWN or WHITE/BLACK	/CS:GREEN
3	GND:BLACK	+V:RED
2	DI:VIOLET or GREEN/BLACK	DO:YELLOW or RED/BLACK
1	ON:BLUE	CL:WHITE

***NOTE: ALL COMPUTER SIGNAL OUTPUTS FROM *SENDER'S POINT OF VIEW*
Connect to Computer or NMEA listening devices

CN3	1	2	3	5	6	9
1	2	3	5	6	9	
1	2	3	5	6	9	
1	2	3	5	6	9	
1	2	3	5	6	9	

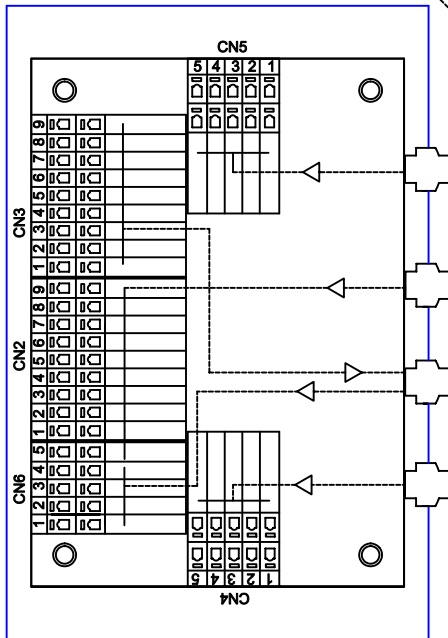

△ Recommended: Connect GPS Compass Power wires (RED & BLACK) to CN6 if Compass is to be ON at all times
by Navigator G2 Display

★ Optional: Connect GPS Compass Power wires (RED & BLACK) to CN2 if Compass is to be powered up & down
by Navigator G2 Display

Vector G2/G2B Compass cable

CN2	1	2	3	4	5	7	8	9
1	2	3	4	5	7	8	9	
1	2	3	4	5	7	8	9	
1	2	3	4	5	7	8	9	
1	2	3	4	5	7	8	9	

OR

Vector G2/G2B Compass cable

CN2	1	2	3	4	5	7	8	9
1	2	3	4	5	7	8	9	
1	2	3	4	5	7	8	9	
1	2	3	4	5	7	8	9	
1	2	3	4	5	7	8	9	

Vector G2/G2B GPS Compass (PN11210001, PN11210002, PN11210004 & PN11210005)
Typical ComNav Navigator G2 wiring diagram



PROJECTION	PROJECT TITLE	SHEET TITLE	DOCUMENT ID. NO.
	MATERIAL SPECIFICATION	FINISH	
	TOLERANCES UNLESS OTHERWISE SPECIFIED	DRAWN BY	
	FRACTIONAL DECIMALS ±1/16"		
	DECIMAL DIMENSIONS 0.0 ±0.020"	DATE	PART NO.
	0.00 ±0.010"	MAR 31, 08	
	BREAK SHARP EDGES 0.02"		SHEET NO.
	M/C SURFACES 125		REV. NO.
			1-1

ComNav® Marine Ltd.
 #15-13511 Crestwood Place
 Richmond, BC Canada V6V 2G1
 Tel: 604.207.1600 Fax: 604.207.8008
 www.comnavmarine.com

Appendix 3

Wiring Termination in the Distribution Unit

This section describes the best practices to terminate and connect the wiring harnesses into the Navigator Distribution Unit Two-Tier Terminal Strips. You may choose to do this if you shorten a wire harness to the length required on your vessel. Tools you will need include:

- Jacket Insulation Strippers,
- Wire Strippers for 22, 20, and 18 Gauge Wires,
- Small slotted screwdriver, and
- Wrenches to tighten Cord Grips

Wires and wire harnesses into the Distribution Unit should be prepared with approximately 12cm (5 inches) of wire pig tails, and between 5mm (1/4 inch) to 9mm (3/8 inch) of bare wire exposed. Figure 26 to Figure 28 illustrates the recommended cable and wire preparation.



Figure 26 - Cable Jacket Removal

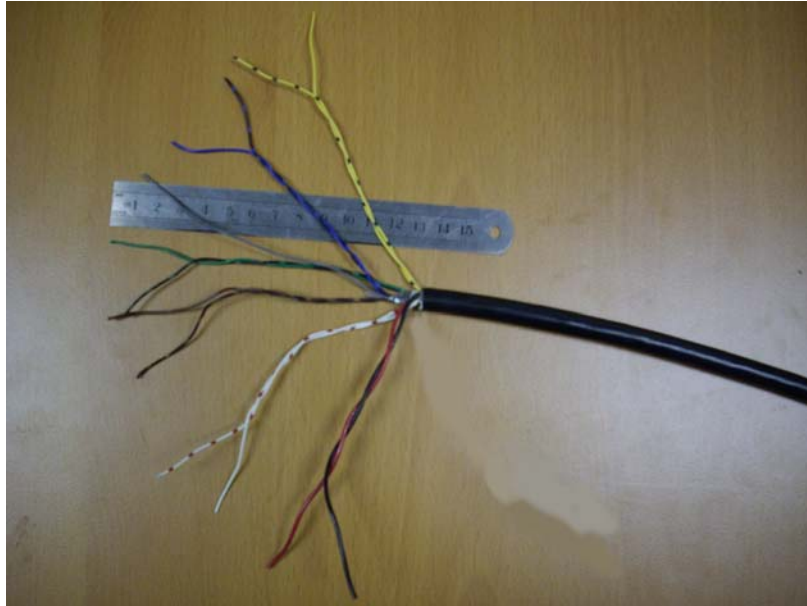

Figure 27 - Cable Shield Removal



Figure 28 - Wire Insulation Removal

Appendix 4

General Specifications

Table 7 – Display Head General Specification

Parameter	Specification
Dimensions	155 x 113 x 29 mm, without knob (6.1 x 4.4 x 1.1")
Color	Gray
Operating Temperature Range	-30° to +80° C (-20° to 175° F)
Cable Length (Max)	7.6 m (25') To Distribution Unit

Table 8 – Distribution Unit General Specification

Parameter	Specification
Dimensions	180 x 160 x 60 mm (7.1 x 6.2 x 2.3")
Color	Gray or White
Power Voltage	12 VDC
Power Consumption	0.6 mADC average with one Control Head
Operating Temperature Range	-30° to +80° C (-20° to 175° F)
Ports Distributed from GPS	Two (2) RS232 full duplex. Two (2) RS422 output only.

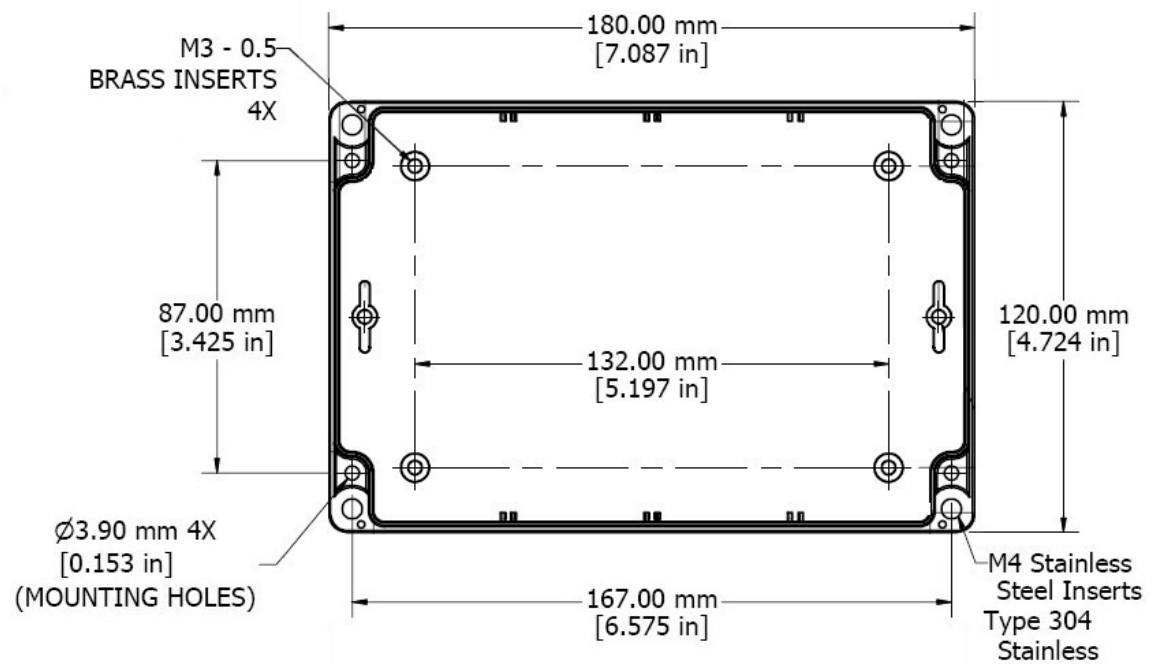

Figure 29 - Distribution Unit Dimensions

Warranty

Warranty Information

Limited Warranty

This Limited Warranty (the "Warranty") covers all Vector and Navigator GPS Compass products & accessories (the "Equipment") sold by ComNav Marine Ltd. ("ComNav").

LIMITED ONE YEAR WARRANTY

ComNav warrants to the Purchaser, provided that the recommended installation and maintenance procedures set forth in the manual (the "Manual") that has been provided with the Equipment have been followed, and subject always to the other provisions of this Warranty, that the Equipment is free from defects in workmanship and materials under normal use and service for a period of one (1) year from the date of purchase of the Equipment by the Purchaser.

EXCLUSIONS

This Limited Warranty is null and void if:

1. The serial number of the Equipment has been removed, altered or mutilated;
2. Any of the anti-tamper seals covering case-screw holes, or other mechanisms for opening the Equipment's case, have been removed, broken or otherwise tampered with;
3. There are any defects in it, or damages to it, caused by:
 - a. Faulty installation or hook-up of the Equipment;
 - b. Abuse, misuse, or any use of the Equipment in violation of the instructions set forth in the Manual;
 - c. Shipping, alterations, or incorrect and/or unauthorized service;
 - d. Accident, exposure of the Equipment to excessive heat, fire, lightning or other electrical discharge, or water immersion;
 - e. Water damage due to failure to fully fasten the plug connected into the Equipment's power/signal receptacle;
 - f. Improper or inadequate ancillary or connected equipment.

OTHER LIMITATIONS AND EXCLUSIONS

1. ComNav does not warrant or guarantee the precision or accuracy of positions, heading, or other GPS-based navigation data obtained when using the Equipment. The potential accuracy of the Equipment, as stated in the Manual, associated ComNav literature and/or Product specifications, provides only an estimate of the highest achievable accuracy based on:
 - a. Specifications provided by the US Department of Defence for GPS Positioning;
 - b. GPS Receiver specifications provided by the OEM manufacturer;
 - c. DGPS service provider performance specifications.
2. The Equipment is not intended for primary navigation or for use in safety of life applications; ComNav does not warrant or guarantee that the Equipment will perform in accordance with the requirements of such usage;

3. ComNav reserves the right to modify the Equipment without any obligation to notify, supply or install any improvements or alterations to existing Equipment.

NO OTHER WARRANTIES

THE FOREGOING WARRANTY IS EXCLUSIVE OF ALL OTHER WARRANTIES AND CONDITIONS, WHETHER WRITTEN, ORAL OR IMPLIED, ARISING BY STATUTE OR OTHERWISE, WITH RESPECT TO THE DESIGN, SALE, INSTALLATION OR USE OF THE EQUIPMENT, INCLUDING BUT NOT LIMITED TO IMPLIED WARRANTIES OR CONDITIONS OF MERCHANTABILITY AND FITNESS FOR THE ORDINARY PURPOSES FOR WHICH THE EQUIPMENT IS USED OR FITNESS FOR A PARTICULAR PURPOSE, AND ANY OTHER OBLIGATIONS ON THE PART OF COMNAV, ITS EMPLOYEES, SUPPLIERS, AGENTS, OR REPRESENTATIVES.

LIMITATION OF LIABILITY

THE EXTENT OF COMNAV'S LIABILITY FOR DAMAGES OF ANY NATURE TO THE END PURCHASER OR ANY OTHER PERSON OR ENTITY WHETHER IN CONTRACT OR TORT, AND WHETHER TO PERSONS OR PROPERTY, SHALL IN NO CASE EXCEED, IN THE AGGREGATE, THE COST OF CORRECTING THE DEFECT IN THE EQUIPMENT OR, AT COMNAV'S OPTION, THE COST OF REPLACING THE DEFECTIVE ITEM. IN NO EVENT WILL COMNAV BE LIABLE FOR ANY LOSS OF PRODUCTION, LOSS OF PROFITS, LOSS OF USE OR FOR ANY SPECIAL, INDIRECT, INCIDENTAL, CONSEQUENTIAL OR CONTINGENT DAMAGES, EVEN IF COMNAV HAS BEEN ADVISED OF THE POSSIBILITY OF SUCH DAMAGES. WITHOUT LIMITING THE FOREGOING, COMNAV SHALL NOT BE LIABLE FOR ANY DAMAGES OF ANY KIND RESULTING FROM INSTALLATION, USE, QUALITY, PERFORMANCE OR ACCURACY OF THE EQUIPMENT.

NOTICE OF DEFECT

The Limited Warranty will not apply with respect to any defective Equipment unless written notice of such defect is given to ComNav, by mail to the address for ComNav set forth below, or by facsimile to ComNav at 604-207-8008, and unless that written notice is received by ComNav within ten (10) days of the date upon which the defect first became known to the Purchaser.

Notices sent by mail from within North America will be deemed to be received by ComNav on the seventh (7th) day first following the date of posting. Notices sent by mail from anywhere else in the world will be deemed to be received by ComNav on the tenth (10th) day next following the date of posting. Notices sent by facsimile will be deemed to be received by ComNav on the date of transmission with appropriate answerback confirmation.

REMEDIES NOT TRANSFERABLE

The Purchaser's remedies under this Warranty apply only to the original end-user of the ComNav Equipment, being the Purchaser, and apply only to the original installation of the Equipment. The Purchaser's remedies under this Warranty are not transferable or assignable by the Purchaser to others in whole or in part.

CUSTOMER REMEDIES

1. If the Equipment, or any part thereof, proves to be defective within the warranty period, the Purchaser shall do the following:
 - a. contact ComNav, by phoning 604-207-1600, to discuss the nature of the problem and to obtain return shipping instructions for the defective Equipment;
 - and,
 - b. prepare a detailed written statement of the nature and circumstances of the defect, to the best of the Purchaser's knowledge, and including the date of purchase of the Equipment, the place of purchase, the name and address of the installer, and the Purchaser's name, address and telephone number, all to be sent, along with proof of purchase, to ComNav at the address set out below, and within the time limits set out above for Notice of Defect.
2. If, upon examination by ComNav, the defect is determined to result from defective workmanship or material and if the defect has occurred within the warranty period set forth above, the Equipment or the defective parts thereof shall be repaired or replaced, at ComNav's sole option, without charge, and shall be returned to the Purchaser at ComNav's expense. Return delivery will be by the most economical means. Should the Purchaser require that the Equipment be returned by a faster method, the costs incurred by the faster delivery will be pre-paid by the Purchaser.
3. No refund of the purchase price for the Equipment will be made to the Purchaser unless ComNav is unable to remedy the defect after having a reasonable number of opportunities to do so.
4. Warranty service shall be performed only by ComNav. Any attempts to remedy the defect by anyone else shall render the warranties set forth in this Warranty null and void.

CHOICE OF LAW AND JURISDICTION

This Warranty is governed by the laws of the Province of British Columbia, Canada. If the Purchaser acquired the Equipment outside of Canada, each of the parties hereto irrevocably attorn to the jurisdiction of the courts of the Province of British Columbia, Canada, and further agree to settle any dispute, controversy or claim arising out of or relating to this Limited Warranty, or the breach, termination, or invalidity of it, by arbitration under the rules of the British Columbia International Commercial Arbitration Centre ("BCICAC"). The appointing authority shall be BCICAC [or, if the BCICAC shall cease to exist, the Chief Justice of the Supreme Court of British Columbia]. BCICAC shall administer the case in accordance with BCICAC Rules. There shall be one arbitrator and the place of arbitration shall be Vancouver, British Columbia, Canada.

The United Nations Convention on Contracts for the International Sale of Goods Act, S.B.C 1990, c. 20, and any other statutory enactments of the United Nations Convention on Contracts for the International Sale of Goods do not apply to this Warranty.

ComNav Maine Ltd.
#15 - 13511 Crestwood Place
Richmond, British Columbia
Canada, V6V 2G1

WARNING

The Equipment is an aid to navigation only. It is not intended or designed to replace the person on watch. A qualified person should always be in a position to monitor the vessel's heading, and to watch for navigational hazards, and should be prepared to revert to manual steering immediately if an undesired change of heading occurs, if the heading is not maintained within reasonable limits, or when navigating in a hazardous situation.

ALWAYS REMEMBER:

***WHENEVER UNDER WAY, A QUALIFIED PERSON ON
WATCH IS REQUIRED BY LAW.***

User Notes

