

Operator Manual

GMDSS Marine Radio Decoder

FMD55P

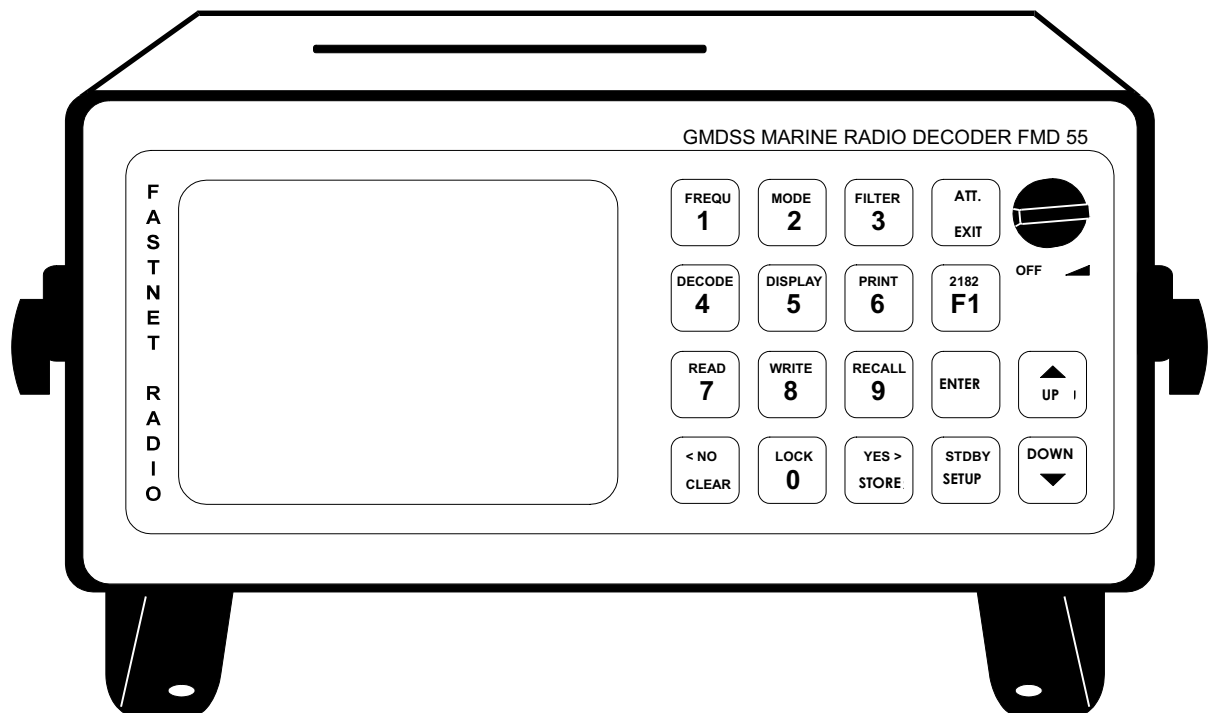

CAUTION!

When installing the system for the first time, or if the unit has not been operating for two to three months, the data stored in memory may be lost due to self-discharge of the integrated rechargeable back-up battery.

The FMD55 will signal data loss acoustically as follows:

Beep: Short - Short - Long - Long - Short

To correct the problem please proceed as follows:

Press the key  to activate the set-up menu

Press 2. **<Set-up_2>**

Press 1 **< Time / Date>**

Enter correct date and time. In case the values displayed were correct, then enter a different value first before reverting to the correct values.

Press  key to return to Stand By mode.

The acoustic alarm should now stop and the FMD55 is returned to normal operating status.

After loss of power e.g. switching off, it is possible that the alarm may sound. Switch off for 5 seconds, if still beeping, press **<EXIT>**.

CONTENTS

1.	Introduction	6
1.1.	Short description of the functions	6
1.2.	Operation	7
1.3.	Keypad functions	7
2.	Receiver (Operation)	10
2.1.	Entering frequencies	11
2.2.	Selecting reception mode	11
2.3.	Adjusting filter	12
2.4.	Reception of field strength	12
2.5.	Storing receiver parameters	13
2.6.	Recalling stored parameters	13
3.	Decoding of Messages	14
3.1.	Selecting mode and decoding types	16
3.2.	Decoding MORSE code signals	18
3.3.	Decoding RTTY signals	18
3.4.	Decoding SITOR signals	18
3.5.	Weather chart reception	19
3.6.	Storing receiver and decoder parameters	21
3.7.	Recalling stored parameters	21
3.8.	Message storage	22
4.	Automatic Reception and Decoding	23
4.1.	Programming the timer	23
4.2.	Interrupting and resetting timer	24
4.3.	Reading stored messages	25
4.4.	Printing out stored messages	25
4.5.	RS232 interface output	26
5.	NAVTEX Reception and Decoding	27
5.1.	Selection of frequency	27
5.2.	Selection of filter for NAVTEX reception	28
5.3.	Selection of transmitting station	28
5.4.	Selecting type of message	29
5.5.	Printer function	30
5.6.	Suppressing repeated messages	30
5.7.	Alarm by A, B and D-type messages	30

5.8.	Printing out NAVTEX parameter status	31
5.9.	Returning to basic Standby mode	31
5.10	Displaying and dealing with errors	31
5.11.	Termination by high error rate	31
5.12.	List of NAVTEX transmission stations	32
6.	Barograph and storm alarm	35
6.1.	Description	35
6.2.	Calibrating barograph	35
6.3.	Activate storm alarm	36
7.	NMEA Printer and Navigation Log	37
7.1.	Printing out NMEA data	37
7.2.	Activating log	38
8.	System SETUP	41
8.1.	Setting time and date	41
8.2.	Setting of owner's and vessel's name	41
8.3.	Switching on and setting timer	42
8.3.1	Switching timer on and off.	42
8.3.2	Automatic return to Standby mode	42
8.3.3	Controlling the display lighting	43
8.4.	Printing out system data	43
8.5.	Deletion of Memory Store and RESET	44
9.	Installation	45
9.1.	Delivery contents	45
9.2.	Installation of unit	45
	Desktop, ceiling and wall installation	47
9.3.	Diagram of unit – reverse side	48
9.4.	Power supply connection	49
9.5.	Record out – tape deck, PC	50
9.6.	Connecting external loudspeaker	50
9.7.	Antenna connection and earthing	51
9.8.	Connecting an active antenna	52
9.9.	Installation suggestion back-stay antenna	53
9.10.	Installation suggestion active antenna MD-AA	54
9.11.	Installation suggestion active antenna R+R	55
9.12.	Printer paper change	56
9.13	Connection for external printer	57
9.14	Connection for RS232 interface	57

9.15	Remote control output (optional)	58
9.16.	Adjusting contrast of LCD display	58
10.	Accessories	59
10.1.	24V DC/DC converter	59
10.2.	DC936-12 Converter for DC 9V – 36V to 12V DC	60
10.3.	Installation of M5X-DC converter	61
10.4.	MD-AA active antenna for FMD55, 50, 56	62
10.5.	MLB long-wire balun transformer for back-stay	63
10.6.	F6A – suppression filter	64
10.7.	Connection cable for NMEA interface	65
11.	Technical Data	66
11.1.	General	66
11.2.	Receiver general	66
11.3.	Receiver features	67
11.4.	Micro controller – signal processor	68
11.5.	LCD display	68
11.6.	Thermal printer	68
11.7	Barograph	69
11.8.	Interfaces (ext. Printer, RS232, NMEA)	69
11.9.	Approvals	71
12.	Information (Stations, Reception Conditions)	
12.1.	Chart W3 – Atlantic forecast areas	
12.2.	W4 – British Isles forecast areas	
12.3.	W5 – Baltic forecast areas	
12.4.	W6 – West Europe forecast areas	
12.5.	W8 – Denmark forecast areas	
12.6.	W12 – France forecast areas	
12.7.	W18 – East Mediterranean forecast areas	
12.8.	W19 – Mediterranean fleet forecast areas	
12.9.	Explanation of wind-forces	
12.11.	Short-wave coverage conditions	71
12.12.	Antenna reception on vessels	
12.13.	Morse code table	73
13.	Examples	75
13.1.	Status information – timer parameters - Baltic	75
13.2.	Status information – Mediterranean	76
13.3.	Print out NAVTEX and MSI	77

13.4.	Print out weather report	78
13.5.	Print out weather chart	79
13.6.	Print out navigation log	80
13.7.	Print out NAVTEX status information	80
14.	Appendix	81
14.1.	Service and maintenance	81
14.2.	Service depots	81
14.3.	Warranties	
14.4.	Software update	82
14.5.	Order form for update	83
14.6.	Error alarm	84
14.6.1..	“PRINTER ERROR” alarm	84
14.6.2..	Further acoustic error alarms	85

1. Introduction

1.1. Short Description of Functions

The FMD55 possesses the following functions:

a) receiver

a highly reliable digitally tuned marine receiver with the following features:

€frequency range	:	30kHz to 30MHz
€receiving modes	:	AM, USB, FSK(LSB), CW.
€Memory storage	:	30 frequencies and modes

b) NAVTEX receiver and decoder

€Frequencies	:	490kHz, 518kHz, 4209.5kHz
--------------	---	---------------------------

c) Decoder

by means of a highly sophisticated signal processor and microcomputer, the following codes are automatically deciphered:

€Morse code	:	40 to 100 bpm
€RTTY	:	50, 75, 100 Bd.
€SITOR-FEC	:	100 Bd.

d) Weather chart receiver

€Reception, decoding and printing out weather chart transmissions according to IOC288 and 576CCIR	
€-RPM	: 60, 90, 120, 240 and auto

e) Barograph and storm alarm

The actual atmospheric pressure is continually measured and displayed. The display shows in stand-by mode a graphic of the previous 24 hrs. By means of data processing, it is possible to evaluate a local storm warning.

f) NMEA printer and position log

Printing of data via the NMEA interface. In combination with a GPS, a navigation log can be stored and printed.

1.2. Operation

With its integrated high-contrast, back-lit display and an easy to use keypad, the FMD55 can be operated simply with its user-friendly dialogue. The printing out of system information and decoded messages is carried out by an integrated or external thermal printer using an 80mm wide thermal paper roll.

1.3. Keypad Functions

FREQU 1	- select frequency input mode - input numeral – 1 -
MODE 2	- select reception mode USB, AM, CW, FSK - input numeral – 2 -
FILTER 3	- select filter band (only in certain modes) - input numeral – 3 -
ATT EXIT	- select/deselect 20db attenuation - return to higher level menu
DECODE 4	- select decoding mode, rotating from USB, AM, CW, FSK and back to USB. - input numeral – 4 -
DISPLAY 5	-select display decoded message -deselect printer - input numeral – 5 -
PRINT 6	- select printing of decoded message - select and activate printer - input numeral – 6 -

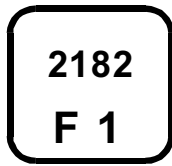

select emergency frequency 2182 kHz
select frequency input mode



stored messages - select
- input



- select storing of received
- input numeral - 8 -



stored frequency - select
- input numeral - 9 -



- confirm stored frequency
- reserved function
- answer
- move cursor left
- clear current input



- reserved function
- input numeral - 0 -



toggle - answer
- move cursor right
- confirm data input





- return to basic standby mode
- activates SETUP menu

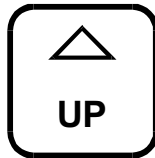

- fine tuning (+)
- move cursor up

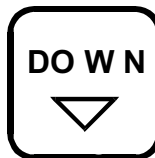

- fine tuning (-)
- move cursor down

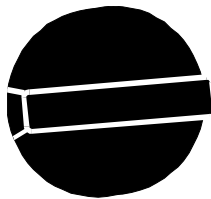

- turn to switch unit ON or OFF
- turn to control the volume

OFF 

1. Receiver (Operation)

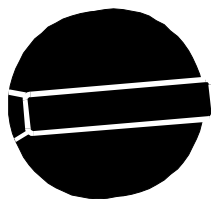

OFF



Switching on for the first time:

Control that the unit is properly connected. Switch on by turning the knob clockwise.

The display will now show the barograph graphic, date, the time in UTC and NAVTEX STBY on.

The unit is now functioning as a NAVTEX decoder on the 518kHz frequency. All incoming messages will be printed out and, an alarm will sound by type A, B and D messages. Changes to the NAVTEX menu can be made as in chapter 5.

ATTENTION !

Frequencies for weather and nautical warnings can be found in official manuals such as

The Admiralty List of Radio Signals volume 3.

Please note that the publishers and the distributors of these manuals cannot be held responsible for the correctness of the frequencies and transmission times. One must take into account that there is a possibility that the printed facts are incorrect. Wherever the contents of different publications contradict, the master's decision must be to withhold from unfavourable statements.

2.1. Entering Frequencies

- € To activate the receiver press the **F1<2182>** key
(should no other input be made, the receiver is tuned to the international emergency frequency 2182 kHz).
- € Press the **<FREQ>** key
- € Enter the frequency in kHz with the numeral keys (correct errors with **<CLEAR>** key).
- € Control that the input is correct and **<ENTER>**.
- € For fine-tuning of the frequency and input of decimal point, use the cursors **<UP>** and **<DOWN>**.

The frequency entered will now be displayed.

2.2. Selecting Reception Mode

The receiver is provided with the following modes:

- € **AM** for the reception of amplitude modulated radio stations (e.g. BBC 4, Valentia, Athens etc.).
- € **CW** for the reception of A1 signals (Morse code from IAR, Roma etc.).
- € **FSK** (frequency shifting key) for RTTY (teletype) and SITOR-NEC transmissions.
- € **USB** (upper side band) for the reception of single side band (SSB) modulated signals.

See also chapter 3 – Page 3-1

For the reception of LSB (lower side band) use the FSK mode.

While in Standby mode, or before the frequency input, the basic mode is USB.

By pressing the **<MODE>** key the mode rotates (toggles) from USB to AM then CW and finally FSK before returning to USB.

The display will show the selected mode.

2.3. Adjusting the Filter

The receiver has several filter band widths to optimise the best possible reception.

The filter band widths are:

10 kHz, 7 kHz, 4 kHz, 2.2 kHz and 500 Hz

Permitted are only those band widths, which cooperate together with the according modes, automatically pre-selected in the decoding mode.

Repeated pressing of the **<FILTER>** key display the following filter band widths for selection:

for AM	:	4, 7 and 10 kHz
		basic setting: 7 kHz
for CW	:	2.2 kHz and 500 Hz
		basic setting: 2.2 kHz
for FSK	:	2.2 kHz and 500 Hz
		basic setting: 2.2 kHz

The basic setting for **USB** is 2.2 kHz and cannot be adjusted. Other filter band widths for SSB are unsuitable.

2.4. Reception of Field Strength

The field strength is displayed as:

>>> |>>>

The first five arrows from the left depict the automatic adjustment control for the signal processor. For reasonable reception, there should be two to three arrows. The arrows appearing to the right of the vertical line depict the field strength reception. Whether four or five arrows are displayed,

a good decoding quality is guaranteed. Interference signals can also lead to a high field strength in display, however the decoding can be strongly influenced by this disturbance.

2.5. Storing Receiver Parameters

The FMD55 is equipped with 30 memory stores, so called channels, in which a station frequency can be stored for later retrieval. Retrieval is possible either by using the **<RECALL>** key or in the timer mode.

The following parameters can be stored:

- € frequency in 10 Hz steps
- € receiving mode (AM, CW, FSK, USB)
- € filter adjustment (500 Hz, 2.2, 4, 7, 10 kHz)

Having checked that all the above parameters for the selected station have been correctly entered then press the **<STORE>** key. Now allot a free channel number from 01 to 30 and **<ENTER>**. The display will now show the parameters stored on this memory store and with the selected slot i.e. **CHxx**.

By pressing the key **<YES>** you can store the currently entered parameters and/or overwrite previous entries stored on this channel

2.6. Recalling Stored Parameters

To retrieve stored receiver parameters press **<RECALL>**.

e.g. using the numeral keys, enter the desired channel number (e.g. 01 for the first entry), and press the **<ENTRY>** key. The contents of storage will be automatically transferred to the receiver.

The storage (channel) numbers and the parameters can also be printed if desired.

Enter SETUP / Menu 2, place cursor on **<7 INFO>** (see chapter 8.1.)

3. Decoding of Messages

The FMD can receive, decode and reproduce messages in legible characters, when transmitted in Morse, RTTY and SITOR-NEC codes. Apart from these codes there are many other code types used in radio communication which are ciphered. These types of messages are not for the general public and can therefore not be decoded by the FMD55.

Weather, SAR and navigational warnings for shipping are transmitted in codes, which the FMD55 can decipher.

The reception signal (LF) is fed to the signal processor where the usable signal tone is filtered out and converted into digital information.

The mode of the type of code transmitted by a station, can be found in corresponding maritime radio manuals. Various abbreviations are used:

for MORSE : CW, A1, A1A, telegraphy
for RTTY : F1B, radio teletype,
for SITOR : FEC, ARQ, F1B

Before a signal can be decoded, it must be reasonably free of interference, (i.e. with the least possible noise ratio, no clicking or crackling, no other disturbing stations in the receiving range). In the top two lines of the LCD display, a signal spectrum is depicted to assist in the adjustment.

Morse signals consist of only one tone. By reception of an undisturbed MORSE signal, the following picture appears on the display

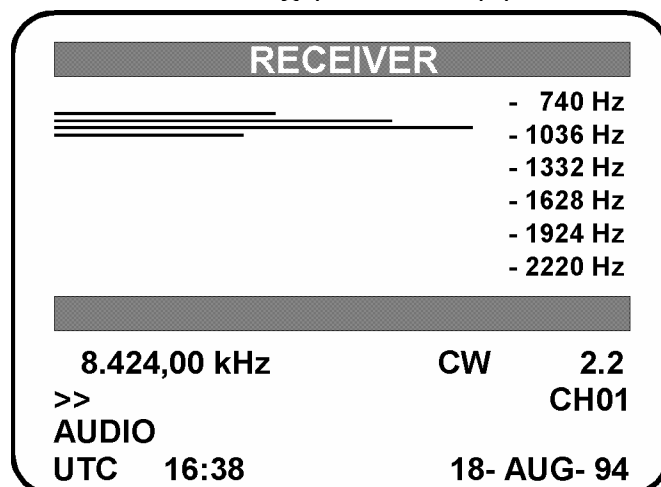

RTTY and SITOR-FEC signals consist of two tones, which alternate uninterruptedly in the rhythm of the information. The two tones can be so close together that the depiction in the display merges. This gives the following picture:

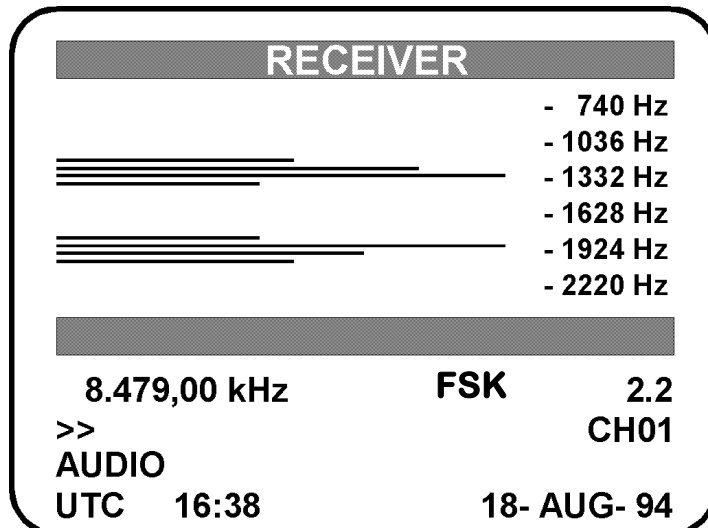

An interference is possible. This is why disturbing signals as well as the required signals are visible on the display.

* The basic FAX set-up menu appears as follows:

PRINT: NORMAL (BLACK on a WHITE background)
SYNC: +0 (picture will be printed vertically)
RPM: 120 (95% transmissions are at 120rpm)
LEVEL: 1500 (level value for black/white)
STATUS: WAIT (adjusts itself automatically to SYNC on receiving the start impulse from the station and through synchronisation signal to PRINT).

In all decoding modes, in the top left and right hand corners of the display header, there are numbers visible. These are the utility frequencies of the signal processor, as it is active even in the stand-by mode for decoding of NAVTEX signals. The number on the left is the lower frequency and right higher. In the MORSE and FAX modes, both values are equal. Morse uses only one tone signals and FAX uses the white picture level value. In RTTY and SITOR (NAVTEX), two signal tones are displayed. The distance between corresponds to the frequency shift of the station.

From the number displayed, the frequency can be calculated as follows:

Frequency = $735 + 7.5 \times n$ (Hz). N = number displayed

The CF of 1500Hz should correspond to the channel number 102. This means that during MORSE decoding, the number appearing should be between 85 to 120. Should the number differ greatly, then it is possible that the frequency is not properly tuned. The white level for FAX in the SW range should lie between 40 and 60. The two frequencies in RTTY and SITOR should be roughly symmetrical around 102. Likewise in NAVTEX they should be symmetrical around 102 but with an additional distance of about 20 to 26.

3.1. Selecting Mode and Decoding Types

In most manuals, the station mode is depicted as A1A, F1B etc. The following table is an overlook of the practised abbreviations for transmission modes in marine radio.

The settings matching for the receiver and decoder can also be taken from the table.

Message Transmission Types

Transmission Mode	receiver set up	decoder set up
A1A - Morse telegraphy with non-damped carrier e.g. Roma, IAR etc.	CW	Morse
A2A - Morse telegraphy in double side band method	CW	Morse
A3E - audio radio in double side band e.g. BBC, 4.	AM	(audio)
F1B - FM telex signal from Pinneberg	FSK	RTTY
F1B - FM telex signal specially for NAVTEX	FSK	SITOR-NEC
F1B - FM telex (MSI frequencies e.g. Portishead: 4211 kHz (402))	FSK	SITOR-FEC
F1C - FM tele-facsimile from Bracknell, Pinneberg etc.	FSK	FAX
F3E - VHF Audio radio from 88 to 108 MHz	*	*
H3E - AM audio radio, SSB with carrier e.g. Murmansk	USB	(audio)
J3E - SSB audio radio	USB	(audio)
R3R - as H3E however with reduced carrier e.g. Niton	USB	(audio)

* - cannot be set by FMD50/55

3.2. Decoding Morse Code Signals

Having chosen a station broadcasting in Morse code, enter the frequency as in Ch. 2.1. Select the CW mode to receive audible signal, (pitch of tone can be fine tuned with keys **<UP>** and **<DOWN>**). Press key **<DECODE>**. The signal processor will now analyse the Morse signal and convert it into a digital signal. The bottom line of the display will now show CARRIER then SIGNAL and. MORSE, After a short period the message will appear in legible characters in the first line of the display. The number in the top corner is the speed of characters per minute. By pressing **<PRINT>** the message can be printed out and "P" appears on the display. Should the message be stored for later display and/ or printing, press **<WRITE>**.and "W" appears in the display and **<ENTER>**. Using the **<DISPLAY>** key you can interrupt printing as well as storing.

3.3. Decoding RTTY Signals

Using the same procedure as in MORSE decoding, enter the frequency chosen and select the mode **<FSK>**. Press the **<DECODE>** key until RTTY appears in display. After a short period, the signal processor will analyse and the decoded message will appear on the display along with CARRIER then SIGNAL. In the case of RTTY the speed of transmission is shown in Baud e.g. 58 Bd. Printing and storing of messages is analogue to that of MORSE.

3.4. Decoding SITOR-FEC Signals

Decoding of SITOR signals is analogue to RTTY via **<FSK>** mode. The safety of the transmission of SITOR signals is far superior to that of RTTY and NAVTEX is also transmitted in SITOR.

Printing and storing of messages, as by MORSE

3.5 Weather Chart Reception

The FMD55 can receive and print out weather charts, (facsimile transmissions in F1C) if they are transmitted according to normal standards.

Before printing out a chart, make sure that that you have a reasonably disturbance free reception. For your assistance, apart of the LCD display is reserved to project the incoming signal. The signal is visible within the 855 to 1920 Hz band. Weather transmissions consist of a signal spectrum in shades of white, grey and black. With a reasonably clear reception, you should the following picture on the display:

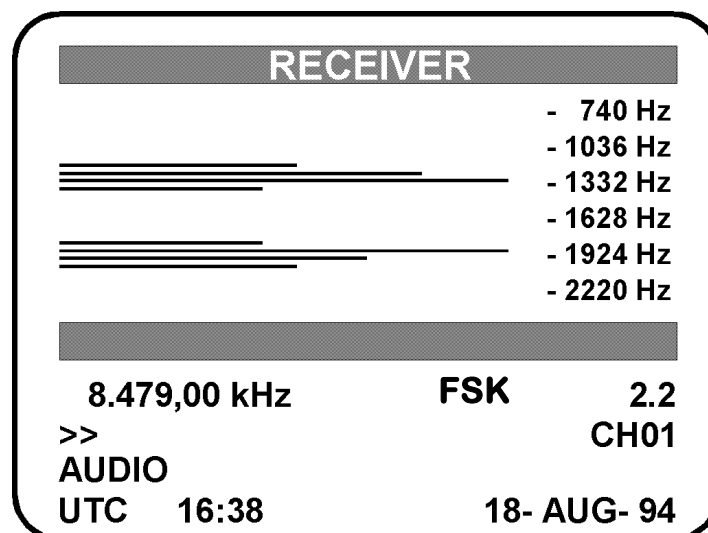

As a rule it is seldom that you have a perfectly clear reception, therefore interference will be visible on the screen as well as the incoming signal. Adjust the receiver that you hear the best possible reception of a chart signal. To do this select the FSK mode. The signal can be found somewhere in a frequency tone range of 1000 to 2000 Hz. Press the **<DECODE>** key until **FAX** appears on the display. A small menu will now appear on the display allowing you to adapt the method of decoding to the signal.

-PRINT: NORMAL/ INVERS allocates correctly, the transmitted signals into BLACK and WHITE

Basic set-up is **NORMAL**.

The integrated printer cannot pick out the grey values, but this is unimportant as weather charts consist mainly of black and white information.

-SYNC: Correction factor for synchronisation.
Basic set-up is **+0**

-RPM: Choose **60, 90, 120, 240** revs per minute
or **AUTO** (automatic recognition)
Generally used: **120 rpm**

A variance is only necessary when the programme is not exactly synchronised.

The projection of a facsimile signal occurs in that the pattern is scanned at a certain speed from the chart lay-out.

This speed must coincide with the evaluation of the decoder, so that the signal is printed out correctly. At the start of a transmission impulses are beamed out, enabling the receiver to synchronise. The FMD is capable of synchronising automatically when on AUTO. However since the transmitting station scans the weather charts at a set speed, by entering the same speed instead of AUTO, the picture quality can be improved.

-LEVEL: Choose between **833 – 1875 Hz** or **AUTO**
basic set-up: **1500** or **AUTO**

In this way the level is set, that a tone will be evaluated either as WHITE or BLACK. The level frequency is set basically at 1500Hz.

Units with software version 4.0 onwards have by selecting <AUTO>, an automatic standard set-up of 1500Hz. Manual adjustment is still possible and after testing the quality of cloud projections, can be stored in the timer.

The STATUS of synchronisation of the decoder is shown in the last line of the display.

-WAIT: means that no synchronisation has been perceived nor any evaluable signal. After receipt of the start impulse, <SYNC> will be displayed for a short time and the printer will be adjusted automatically.

At this moment <PRINT> will appear on the display.

By pressing <PRINT>, possibly more than once, the print out can be initialised manually. Initialising after the synchronisation signal is not possible as the start of the line will not be recognised. When the decoder is activated before the beginning of a weather chart transmission and the synchronisation has been correctly recognised, the print out will commence automatically.

The parameters for the reception of a weather chart transmission can also be stored and can be **RECALLED** into activation. It is simpler to store the parameters in the **TIMER** function.

3.6. Storing Receiver and Decoder Parameters

The FMD55 has 30 memory stores called channels and as already described in Ch. 2.5. via the **<RECALL>** key the following stored parameters can be recalled:

- € Frequency in 10 Hz steps
- € Receiving mode (AM, CW, FSK, USB)
- € Filter adjustments (500 Hz, 2.2, 4, 7, 10 kHz)
- € Decoding mode (MORSE, RTTY, SITOR)
- € Printer selection (P – PRINT)
- € Store message selection (W – WRITE)

To allot a memory store number, proceed as in Ch 2.5.

3.7. Recalling Stored Parameters

To retrieve stored receiver parameters press **<RECALL>**.

Using the numeral keys, enter the desired channel number (e.g. 01 for the first entry), and press the **<ENTRY>** key. The contents of storage will be automatically transferred to the receiver.

The storage (channel) numbers and the parameters can also be printed if desired.

Enter SETUP / Menu 2, place cursor on **<7 INFO>**

3.8. Memory Storage

The FMD55 has two separate and independent memory stores for decoded messages. One is for NAVTEX messages (see Chapter 5.) and the other is for MORSE; RTTY and SITOR. The latter has a total capacity of 14000 characters. A message of maximum 3600 characters can be stored in one data record. Should the message be longer, then additional records will be opened. Altogether 100 record with a total capacity of 14000 characters can be set up. When the memory storage is full while storing, the oldest record will be deleted to make space for the new one. This means that the latest or most up to date message will be stored independent of the type of code (MORSE, RTTY, SITOR). It can happen that a message containing only a few characters deletes a complete record of 3600 characters thus reducing the capacity to 10400 characters. Each data record is filed under date and time when the message ended plus one minute, in the formation: DDMMhhmm. Further, the data record contains the channel source and arranges itself under this channel for recalling. Should the FMD55 be switched off, deliberately or not (e.g. interruption of supply), then the data record being currently stored will be deleted because of the incomplete closure. It can happen that because of heavy disturbance in the power supply (e.g. engine start with low batteries), the recognition of the data records has been destroyed or partly destroyed so that the stored message can only be partly read out or eventually not at all. When switched on again the unit may not recognise the record and delete it. Newly decoded messages will in any case be correctly stored.

3. Automatic Reception and Decoding

The FMD55 has 9 timer stores each containing an ON and OFF time and a store number similar to a video recorder. When programming, for safety reasons, it is advisable to add a minute to the ON time and to the OFF time. From experience, a weather forecast can take approximately:

- € MORSE transmissions : 30 minutes
- € RTTY transmissions : 15 minutes
- € SITOR transmissions : 10 minutes

The FMD55 switches on automatically to the stored frequency at the selected ON time and decodes according to the stored parameters. The message will be stored when "W" – WRITE has been selected or printed out directly when "P" – PRINT has been selected.

On reaching the OFF time, the FMD55 automatically returns to the basic STANDBY mode and is in the NAVTEX reception mode.

Before programming the timer, all parameters must have been pre-stored as in Chapter 2.5.

4.1. Programming the Timer

Startina from the standby mode:



ss to call up MENU 1

€ Press key <!> or <ENTER> to select timer

€ Press <ENTER>

Now you can insert the times and channel with the cursors:



Keys <YES> and <NO> set the cursor on the position and the keys <UP> and <DOWN> adjust the figure value. Keys <UP> and <DOWN> have an auto-repeat function, which means that the figure rotates as long as the key is depressed.

Unless you press <ENTER> it is possible to change the values until they are correct. Having controlled that all data is correct then <ENTER>. By pressing <ENTER> once more you come to a new insertion line and can programme additional times. It is also possible to delete insertions as follows:

€ Press



- € Select by means of the numerals <1> to <9> the line to be deleted
- € Press <ENTER> to delete.

By pressing the <EXIT> key twice, the unit returns to the basic standby mode.

One timer slot has a maximum of 60 minutes, however it is possible to commence a new slot with the same ON time as the previous OFF time. Should the programmed times overlap, the new time is dominant. When interrupting by manual operation e.g. calling up a new frequency, the unit returns to the standby mode. Should this not be wished, the timer must be turned off completely via the menu.

4.2. Interrupting and Resetting Timer

By pressing <STDBY> or <F1/2182> you can interrupt an incoming message. At the end of each OFF time, the unit will return to the standby mode automatically. To continue in the current incoming message, switch off for 3-5 seconds.

4.3. Reading Stored Messages

Stored messages can be read out at discretion. However NAVTEX messages are automatically deleted after 72 hours. The memory store has a total capacity of over 16000 characters of which approx. 4500 are reserved for NAVTEX and the rest for MORSE, RTTY and SITOR. When the store is full, the oldest message will be deleted. However this applies to the two different stores separately e.g. a new RTTY message will not replace a NAVTEX message and vice versa. Each message is filed under date and time as: DD MM HH MM (day, month, hour and minute)

- € Press the **<READ>** key call up **READ MEMORY** menu
- € Select type of message to be read with keys **<1>** to **<4>** or **<UP>** and **<DOWN>**

The display will now show an overall view of the stored messages.

By using the cursor keys:



Select the message required.

- € Press the **<DISPLAY>** key and the selected message will appear on the LCD
- € With the use of the keys **<UP>** and **<DOWN>** you can turn the pages. Either by pressing **<EXIT>** or on reaching the end of the message you can leave the **<READ>** mode.
- € To return to the basic standby mode, press **<EXIT>** once more.

4.4. Printing Out Stored Messages

Stored messages can be printed out as often as required. The selection of the message is carried out as by reading out above.

- € Press the **<READ>** key call up **READ MEMORY** menu
- € Select type of message to be read with keys **<1>** to **<4>** or **<UP>** and **<DOWN>**

The display will now show an overall view of the stored messages.
By using the cursor keys:

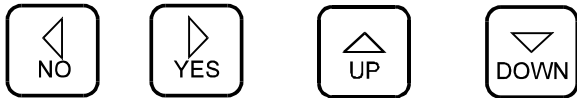

Select the message required.

- € Press the **<DISPLAY>** key and the selected message will appear on the LCD

- € Press **<PRINT>** and the message can be printed out from the beginning to the end or when stopped by pressing **<EXIT>**. However it is possible to print out only part of a message e.g. the segment relating to your particular sailing area. When in **<DISPLAY>** read the pages with the keys **<UP>** and **<DOWN>** until you have the forecast area you require
- € Now press **<PRINT>** and the printer commences from the page displayed.
- € To stop press **<EXIT>** as above to interrupt the printing mode
- € Press **<EXIT>** once more to return to the basic standby mode.

4.5. RS232 Interface Output

The FMD55 has an RS232 interface through which stored message data can be extracted to an external printer or a pc system.

Message out-put:

- € Press read to enter **<READ MEMORY>** menu
- € Select type of message for out-put by means of the keys **<!>** to **<4>** or cursors **<UP>** and **<DOWN>** and **<ENTER>**.
The display now shows an overall view of the stored messages. Again select the message required with the cursors **<YES>** and **<NO>** and **<UP>** and **<DOWN>**.

- € Press **<WRITE>** and the selected message will be transferred at a speed of 9600 Baud via the RS232 interface.

5. NAVTEX Reception and Decoding

When the unit is in the basic standby mode it will receive NAVTEX messages **automatically** when in reach of a NAVTEX transmission station. However it is important to know that:

during reception of other stations or when a stored frequency is being received in the timer function, NAVTEX cannot be received.

In order to obtain the best reception of NAVTEX information, it is advisable to set certain system parameters.

The input of the system parameters is carried out as follows:

- € Pre  key to enter **SETUP 1** menu
- € Press key No. **<2>** to enter **SETUP 2** menu
- € Press key No. **<3>** to enter **NAVTEX** menu

5.1. Selection of the frequency

The FMD55 can receive all three international NAVTEX frequencies at present available for NAVTEX:

- 518** kHz for coastal areas – messages in English
- 490** kHz for coastal areas – messages in local language
- 4209.5**kHz for tropical areas – messages in English

- € Press key **<1>** to enter **<FREQUENCY>** mode
- € By using the cursors **<UP>** and **<DOWN>** you can select one of the frequencies (490, 518, 4209.5 kHz). The basic setting is 518 kHz. Fine tuning is not necessary since the signal processor compensates minor frequency deviation.
- € To return to NAVTEX menu press **<EXIT>**.

The last frequency appearing on the display is now stored

5.2. Selection of Filter for NAVTEX Reception

From version 3. onwards, the FMD55 has a filter with a centre frequency of 1500 kHz and a band width of approx. 500 Hz in place of the 800 Hz filter. Since NAVTEX is broadcast world-wide with a shift of +/- 85 Hz, this filter can be used for NAVTEX transmission. This is recommendable when in the NAVTEX frequency is disturbed by other stations in your sailing area.

Basically for NAVTEX transmissions, the 2.2 kHz has been selected. The 500 Hz filter can be switched on or off as follows:

As in 5.1. enter the **<FREQUENCY>** menu and by pressing:

- € the **<YES>** key you can switch on the filter
- € the **<NO>** key you can switch the filter off.

Which ever filter is selected, it will be shown as a footnote on the print out of a NAVTEX message or on the print out of the NAVTEX status.

5.3. Selection of Transmitting Station

In the **<NAVTEX>** menu

- € press No. **<2>** to enter **<STATION>** mode

The stations are pre-fixed with the letters **A** to **Z**. Station messages desired are given capitol letters and stations to be suppressed with small letters. To do this use the following cursors:

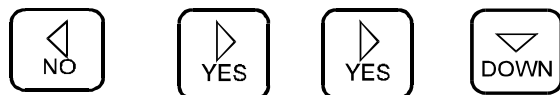

To select the stations required.

By using the keys **<YES>** and **<NO>** you can select the letter required, with the cursor **<UP>** you can change the letter to a capital and with **<DOWN>** to a small letter (this means suppressed).

An up-to-date (as of Spring 1995) overall view of NAVTEX stations can be found in 5.12.

€ press the **<EXIT>** key to return to **<NAVTEX>** menu.

5.4. Selecting Type of Message

In the **<NAVTEX>** menu

€ press No. **<3>** to enter **<MESSAGE>** mode

The type of message is also labelled with the letters **A** to **Z**. The selection of the message type similar to the selection of the station

The following message types were laid down by the international authorities:

A = Navigational warnings

B = Meteorological warnings

C = Ice reports

D = SAR information

E = Meteorological forecasts

F = Pilot service messages

G = DECCA messages

H = LORAN messages

I = OMEGA messages

J = SATNAV messages

K = other navigational assistance messages

L = other navigational warnings

V - Y = special messages, tests, trials

Z = no messages pending.

Messages of types **A, B,** and **D** cannot be suppressed

€ Press **<EXIT>** to return to **<NAVTEX>** menu

4.5. Printer Function

If desired, but in general this is not the case, NAVTEX messages can be printed out on receipt.

- € From the **<NAVTEX>** menu press No. **<4>** to enter **<PRINT>** mode
- € Answer with **<YES>** if the message should be printed on receipt or
- € answer with **<NO>** if the message should be stored for reading later or printing if desired.
- € Press **<EXIT>** to return to **<NAVTEX>** mode.

4.6. Suppressing Repeated Messages

Current NAVTEX messages are repeated every 4 to 6 hours. To suppress the repetition of a message already stored:

- € from the **<NAVTEX>** mode press No. **<5>** to enter **<REPEAT>** mode
- € answer with **<NO>** to hinder repetition
- € return to **<NAVTEX>** mode by pressing **<EXIT>**

4.7. Alarm by A, B and D Type Messages

Messages of the type **A** (navigational warnings), **B** (meteorological warnings) and **D** (SAR information), cannot be suppressed and in fact can be foreseen with an acoustic alarm. To do this:

- € from the **<NAVTEX>** mode press No. **<6>** to enter **<ALARM>** mode
- € should you desire an alarm signal on receipt of an A, B or D type message answer with **<YES>** and
- € return to **<NAVTEX>** mode by pressing **<EXIT>**.

5.8. Printing Out of NAVTEX Parameter Status

For control purposes all selected parameters can be printed out. This print out will show the frequency, filter, selected messages and stations as well as a list of stored NAVTEX messages.

∄ From the <NAVTEX> mode press No. <7>

∄ To return to <NAVTEX> mode press <EXIT>

5.9. Returning to Basic Standby Mode

This can be done by pressing the <EXIT> key three times or the keys <8>, <8> and <3> in this sequence.

5.10. Displaying and Dealing with Errors

The SITOR code used by NAVTEX can recognise errors. Every data field, to which a character has been assigned, will be repeated and have a relationship of 4:3 bit. Only when both data fields match and are valid does the corresponding character appear as a capital letter. Should it be recognised as valid only once, then it will appear as a small letter. If both assigned data field characters be non-valid, then it will appear as an * (asterisk). It is not common form of expression. We are of the opinion that a small letter holds more information than an asterisk *.

5.11 Termination of High Error Rate

When deciphering NAVTEX, the error rate of the decoded signal will be examined. Should the acceptance rate be exceeded, then the print out, if activated, will be interrupted and the message will be automatically deleted from the memory store.

5.12 Current List of NAVTEX Transmission Stations

North Sea, Gulf of Bothnia, Finnish Gulf :

Bodoe R, NOR	LGP	B	0018, 0418, 0900, 1218, 1618, 2100
Cullercoast R, G	GCC	G	0048, 0448, 0848, 1248, 1648, 2048
Oostende R, BEL	OST	T	0248, 0648, 1048, 1448, 1848, 2248
Oostende R, BEL	OSU	M	0200, 0600, 1000, 1400, 1800, 2200
Rogaland R, NOR	LGQ	L	0148, 0548, 0948, 1348, 1748, 2148
Stockholm Radio (64 28N, 2126E)	SDJ	H	0000, 0400, 0800, 1200, 1600, 2000
Stockholm Radio (55 29N, 14 19E)	SDJ	J	0330, 0730, 1130, 1530, 1930, 2330
Stockholm Radio (59 16N, 18 43E)	SDJ	U	0030, 0430, 0830, 1230, 1630, 2030
Vardoe R, NOR	LGV	V	0300, 0700, 1100, 1500, 1900, 2300

South Atlantic

Bahia Blanca R, ARG	L2N	D	0210, 0810, 1410, 2010
Buenos Aires R, ARG	L2B	F	0510, 1110, 1710, 2310
Comodoro Rivadavia	L2W	C	0040, 0640, 1240, 1840
Rio Gallegos R, ARG	L3I	B	0410, 1010, 1610, 2210

West Pacific, Sea of Japan

Adak, USA	NOJ	X	0340, 0740, 1140, 1540, 1940, 2340
Antofagasta, CHL	CBA	A	0400, 1200, 2000
Astoria, USA	NMW	W	0130, 0530, 0930, 1330, 1730, 2130
Bangkok, THA		F	0050, 0450, 0850, 1250, 1650, 2050
Beringovskiy R, FE, CIS		UCT2	E 0040, 0440, 0840, 1240, 1640, 2040
Callao, Peru	OBC3	U	0320, 0720, 1120, 0520, 1920, 2320
Dalian, CHI	XSZ	R	0250, 0650, 1050, 1450, 2250
Gangzhou, CHI	XSQ	N	0210, 0610, 1010, 1410, 2210
Guam, USA	NRV	V	0100, 0500, 0900, 1300, 1700, 2100
Honolulu, USA	NMO	O	0040, 0440, 0840, 1240, 1640, 2040
Isle de Pascua		F	0450, 1250, 2050
Kholmsky R, FE, CIS, UFO		B	0010, 0410, 0810, 1210, 1610, 2010
Kushiro R, J	JNX	K	0140, 0540, 0940, 1340, 1740, 2140
Magadan R, FE, CIS		UVD	D 0030, 0430, 0830, 1230, 1630, 2030
Moji R, J	JNR	H	0110, 0510, 0910, 1310, 1710, 2120
Mollendo, Peru	OBF4	W	0340, 0740, 1140, 1540, 1940, 2340
Naha R, J	JNB	G	0100, 0500, 0900, 1300, 1700, 2100
Otaru R, J	JNL	J	0130, 0530, 0930, 1330, 1730, 2130
Paita, Peru	OBY	S	0300, 0700, 1100, 1500, 1900, 2300
Petropavlovsk-K R, FE, UBE4		C	0020, 0420, 0820, 1220, 1620, 2020
Prince Rupert, Can	VAJ	D	0030, 0430, 0930, 1230, 1630, 2030

Provideniya R, FE, CIS	UPB	F	0050, 0450, 0850, 1250, 1650, 2050
Puerto Montt, CHL	CBP	D	0430, 1230, 2030
Punta Arenas, CHL	CBM	E	0440, 1240, 2040
San Francisco, USA	NMC	C	0400, 0800, 1200, 1600, 2000, 2400
Singapore, Jurong	9VG	C	0020, 0420, 0820, 1220, 1420, 2020
Shanghai, CHI	XSG	Q	0240, 0640, 1040, 1440, 2240
Talcahuano, CHL	CBT	C	0420, 1220, 2020
Tofino, CAN	VAE	H	0110, 0510, 0910, 1310, 1710, 2110
Vladivostok R, SE, CIS	UIK	A	0000, 0400, 0800, 1200, 1600, 2000
Yokohama R, J	JGC	I	0120, 0520, 0920, 1320, 1720, 2120
Kodiak, ALS, USA	NOJ	J	0300, 0700, 1100, 1500, 1900, 2300
Long Beach, Camb.	NMQ9	Q	0045, 0445, 0845, 1245, 1645, 2045
Valparaiso R, CHL	CBV	B	0410, 1210, 2010

Indian Ocean, Gulf of Arabia, Red Sea

Ambon, IN		B	0010, 0410, 0810, 1210, 1610, 2010
Bombay R, IND	VWB	G	0100, 0500, 0900, 1300, 1700, 2100
Damman R, ARS	HZG	G	0005, 0605, 1205, 1805
Hong Kong	VRX	L	0150, 0550, 0950, 1350, 1750, 2150
Jakarta, IN	PKX	E	0040, 0440, 0840, 1240, 1640, 2040
Jayapura, IN	PNK	A	0000, 0400, 0800, 1200, 1600, 2000
Madras R, IND	VWM	P	0230, 0630, 1030, 1430, 1830, 2230
Makkasar, IN		D	0030, 0430, 0830, 1230, 1630, 2030
Muscat, Oman	A4M	M	0200, 0600, 1000, 1400, 1800, 1905
Hamala R, BHR	A9M	B	0010, 0410, 1810, 1210, 1610, 2010
Serapeum R, EGY	SUZ	N	0750, 1150, 1550, 1950

Mediterranean, Black Sea

Alexandria	SUH	N	0610, 1010, 1410, 1810
Antalya R, TUR	TAL	F	0050, 0450, 0850, 1250, 1650, 2050
Augusta	IQA	S	0300, 0700, 1100, 1500, 1900, 2300
Bari	IPB	U	0320, 0720, 1120, 1520, 1920, 2320
Cagliari	IDC	T	0310, 0710, 1110, 1510, 1910, 2310
Cape Town	ZSC	C	0020, 0420, 0820, 1220, 1620, 2020
Cross Corsen, F		A	0000, 0400, 0800, 1200, 1600, 2000
Cross La Garde (Toulon)		W	0340, 0740, 1140, 1540, 1940, 2340
Durban	ZSD	O	0220, 0620, 1020, 1420, 1820, 2220
Iraklion R, GRC	SVH	H	0110, 0510, 1910, 1310, 1710, 2110
Ismailia (Serapeum)		X	0750, 1150, 1550, 1950
Israel, Haifa		P	0230, 0630, 1030, 1430, 1830, 2230
Istanbul R, TUR	TAH	D	0030, 0430, 0830, 1230, 1630, 2030
Izmir R, TUR	TAN	I	0120, 0520, 0920, 1320, 1720, 2120
Kerkyra R, GRC	SVK	K	0140, 0540, 0940, 1340, 1740, 2140
Limnos R, GRC	SVL	L	0150, 0550, 0950, 1350, 1750, 2150
Malta,	9HD	O	0220, 0620, 1020, 1420, 1820, 2220
Mariupol R, UK, CIS	USU	B	0100, 0500, 0900, 1300, 1700, 2300
Novorossiysk R, RU, CIS	UFN	A	0300, 0700, 1100, 1500, 1900, 2300
Odessa R, UK, CIS	UTW	C	0230, 0630, 1030, 1430, 1830, 2230

Port Elizabeth	ZSQ	I	0120, 0620, 1020, 1420, 1820, 2220
Roma, I,	IAR	R	0250, 0650, 1050, 1450, 1850, 2250
Samsun R, TUR	TAF	E	0040, 0440, 0840, 1240, 1640, 2040
Split R, CRT	9AS	Q	0250, 0650, 1050, 1450, 1850, 2250
Tarifa, ESP	EAC	G	0100, 0500, 0900, 1300, 1700, 2100
Troodos R, CYP	5BA	M	0200, 0600, 1000, 1400, 1800, 2200
Varna R, BUL	LZW	J	0130, 0530, 0930, 1330, 1730, 2130

Atlantic, Bering Sea, Engl. Channel, Sea of Norway

Arkhangelsk Rus.	UGE	F	0200, 0600, 1000, 1400, 1800, 2200
Bermuda	ZBM	B	0010, 0410, 0810, 1210, 1610, 2010
Boston, USA.	NMF	F	0445, 0845, 1245, 1645, 2045, 0045
Horta, AZR	CTH	F	0050, 0450, 0850, 1250, 1650, 2050
Ijmuiden CGd, NL	PBK	P	0348, 0748, 1148, 1548, 1948, 2348
Labrador, CAN	VOK	X	0350, 0750, 1150, 1550, 1950, 2350
La Coruna (Sp.).	EAF	D	0030, 0430, 0830, 1230, 1630, 2030
Las Palmas (CI)	EAL	I	0120, 0520, 0920, 1320, 1720, 2120
Lisbon, POR	CTV	R	0250, 0650, 1050, 1450, 1850, 2250
Miami, USA	NCF	A	0000, 0400, 0800, 1200, 1600, 2000
Montreal, CAN	VFN	X	0340, 0740, 1140, 1540, 1940, 2340
Murmansk R, RU, CIS.	UMN	C	0120, 0520, 0920, 1220, 1720, 2120
New Orleans, USA	NMG	G	0300, 0700, 1100, 1500, 1900, 2300
Niton R, GB	GNI	S	0018, 1418, 0818, 1218, 1618, 2018
Portpatrick R, GB	GPK	O	0130, 0530, 0930, 1330, 1730, 2130
Portsmouth, USA	NMN	N	0130, 0530, 0930, 1330, 1730, 2130
Reykjavik R, ISL	TFA	R	0318, 0718, 1118, 1518, 1918, 2318
San Juan, Pto Rico	NMR	R	0200, 0600, 1000, 1400, 1800, 2200
Sept Isles, CAN	VCK	C	0020, 0420, 0820, 1220, 1620, 2020
St. Johns, CAN	VON	O	0220, 0620, 1020, 1420, 1820, 2220
Sydney, NS, CAN	VCO	Q	0240, 0640, 1040, 1440, 1840, 2240
Tarifa (Gibraltar)	EAC	G	0100, 0500, 0900, 1300, 1700, 2100
Thunder Bay, CAN	VBA	P	0230, 0630, 1030, 1430, 1830, 2230
Wiaraton, CAN	VBC	H	0110, 0510, 0910, 1310, 1710, 2110
Yarmouth, CAN	VAU	U	0320, 0720, 1120, 1520, 1920, 2320

6. Barograph and Storm Alarm

6.1 Description

The FMD55 has an integrated precision atmospheric pressure sensor with an amplifier and scoring logic. The graphic range is 950 to 1080 hPa (mbar). The pressure is continually measured and the average evaluation is stored for 24 hours. The current value is displayed numerically in the top right hand corner of the LCD. The average evaluation of the past 21 to 24 hours is shown graphically on the display. The time axis is horizontal. The difference between two lines is one hour. The line is intensified every three hours. The hour numerals are at the foot of the graphic. The atmospheric pressure is depicted vertically. The distance between two horizontal lines is equivalent to 2 hPa. The page moves to the left every three hours.

6.2. Calibrating the Barograph

The sensor feeder is absolutely correct and to a great extent, temperature compensated. The barograph should be calibrated after the initial installation and, subsequently after every considerable change of climate caused by positional movement. Before calibration, the FMD55 should be operating for 10 hours in a fixed position. For calibration you require the absolute true atmospheric pressure reading at your fixed position. This reading can be obtained from the local weather station, marina or airport. Please make sure, that there is the least possible difference in altitude between the point where measurements were taken and the FMD55. The calibration is very simple:

- € press the <STDBY> key to set-up menu 1
- € press key <2> to set-up menu 2
- € press key <4> to select **BAROSCOPE** (barograph)
- € press key <2> to enter calibration

You can now enter the indicated value by means of the numeral keys. In case of a mistake in input delete with **<CLEAR>** key.

After checking that all values are correct

- € Press **<ENTER>** to accept the new values and
- € Press **<EXIT>** to return to the basic stand-by mode.

The newly input values appear now in the display as the current measurement. The correction throughout the complete measuring range will be carried out automatically by the micro processor.

6.3. Activating the Storm Alarm

Should there be a sudden drop or rise of atmospheric pressure within the time axis, one can reckon locally with a change in the speed of the wind within very short notice. Using a corresponding formula, the FMD55 observes these changes. In order that the alarm does not sound at the lightest change, it can be adjusted to the required response level. By pressing **<EXIT>**, the alarm can be switched off. Similar to the calibration set-up the barograph menu.

- € Press key <1> to enter <GALE WARNING> menu.

Use keys <YES> and <NO> to switch the warning alarm ON or OFF and keys <UP> and <DOWN> to adjust the response level.

The following values can be used as a guide:

- € at sea : 1.5 to 3.0 hPa in 3 hours
- € level surroundings : 1.5 to 6.0 hPa in 3 hours
- € mountainous surroundings: 3.0 to 9.9 hPa in 3 hours

After checking that the input is correct return to the basic stand-by mode by pressing the <EXIT> key. The values have now been accepted and stored.

In case of over-sensitive release of alarm, increase the response level value.

7. NMEA Printer and Navigation Log

7.1. Printing of NMEA data

The FMD55 can be used as an NMEA printer. In this mode NMEA signals are fed via the NMEA 0183 interface **unaltered** to the integrated or external printer.

Please note, that only data, which are defined as NMEA data, can be processed.

The unit, which is destined to supply NMEA data (GPS, compass, log etc.), should be connected to the NMEA input of the FMD55.

- € Press **<SETUP/STDBY>** to enter **<SETUP 1>** menu
- € Press No. **<2>** to enter **<SETUP 2>** menu
- € Press No. **<2>** to enter **<NMEA>** menu
- € Press No. **<1>** to enter **<NMEA-PRINTER>**.

The FMD55 is now operating as an NMEA 0183 printer. When data comes from the connected device it will be printed out unaltered. Since NMEA data is transmitted in a one second rhythm, it is advisable not to leave the unit in this mode for a longer period, in order to save paper. This function of the FMD55 is suitable for checking and documenting NMEA signals.

The mode can be interrupted as follows:

- € Press **<EXIT>** three times to return to standby mode.

ATTENTION:

During the function <NMEA PRINT> the FMD55 cannot operate other functions. This means that cannot receive NAVTEX messages nor do the timer functions operate!!

7.2. Activating log

When connected via NMEA 0183 interface to an external GPS, it is possible with the FMD55 to receive, store and print out the NMEA data record "GPS transit specific \$ GPRMC", which is practically a complete record of the route.

The formula for this data record must read as follows:

```
$GPRMC,111111,A,2222.222,N,33333.333,W,44.555.,  
666666,77.,E*CS
```

All variants of this \$GPRMC data record with the different periods and commas will be recognised and processed. Other data records other than RMC type will not be recognised!!

The RMC data record has been defined however as the standard data record for GPS equipment, so that all well known models can be easily connected.

The contents of the data record are:

111111	-time in hhmmss
A	-identity if data valid (A) or invalid (V)
2222.222	-latitude in degrees, minutes, 1/1000mins
N	-direction - (N) north, (S) south
33333.333	-longitude in degrees, minutes, 1/1000mns
W	-direction - (W) west, (E) east
44.44	-speed over ground (SOG in Kns)
555	-heading over ground (degrees)
666666	-date as DDMMYY
77	-deviation value
E*	-check value

This data record will be memorised and stored by the FMD55. The storage can hold 50 data records. When the storage is full, the data will be automatically printed out.

To control the continual amount of data, two parameters can be selected to define the information according to your personal wish.

Parameter 1: time from 1 to 99 minutes

You can select, in which time intervals the position should be stored, even when there has been no movement (e.g. at anchor, in berth).

If <00> is entered as time parameter, there will be no time-defined entry. This saves data records being stored and printed out, when the vessel is stationary for a longer period of time.

Parameter 2 positional movement in minutes (1 to 9n.m.)

You can also select, independent from the time interval, a distance after which the position of your vessel should be documented. For easy calculation, the values north/south and east/west are separated.

To activate the log:

- > press **<SET UP>** button
- > press no. **2** to enter **GPS LOG**
- > to activate the log function press **<YES>**. (press **<NO>** to switch off)
- > use cursor **<DOWN>** to spring to position **TIME**
- > select the TIME interval with **<YES>/<NO>** keys
- > use cursor **<DOWN>** to spring to position **WAY**
- > select the WAY interval with **<YES>/<NO>** keys
- > press **<EXIT>** 4 times to return to stand-by

The FMD55 navigation log function will work even when other functions e.g. reception, decoding are in process. Only when an incoming NAVTEX message or a longer decoding is taking place, will the position log be interrupted, however it will commence immediately at the end of the message. At any given time, 50 position data will be stored. After every 50th value, the storage will be printed out automatically. This does not take place during message decoding or when the FMD55 is being operated manually, but as soon as the FMD55 returns to the stand-by mode.

However, you can print out the actual stored data at any time. To do this:

- € call up the **GPS LOG**
- € press **<PRINT>**

When the print out has ended, the display will ask:

<DELETE ALL?>

Press **<YES>** to delete all position data in the storage or press **<NO>** to save the data. On receipt of new data, the oldest will be automatically deleted.

Using the above function, it is manually possible to print out the log daily. An automatic deletion after print out was deliberately waived to make it possible to repeat the print out should there be a printer error.

8. System Set-up

8.1. Setting Time and Date

- € Press the **<SETUP>** key to enter the **SETUP 1** menu
- € Press key No. **<2>** to enter **SETUP 2** menu
- € Press key No. **<1>** to enter **<TIME>** mode

Use the cursors



to enter the correct time (preferably **UTC**) and the date
The keys **<UP>** and **<DOWN>** have an “auto-repeat” function so that you can alter the figures as often as required by continual depressing.

Having checked that all data has been correctly input, press the **<EXIT>** key 3 times to return to the basic standby mode.

8.2. Setting of Owner's and Vessel's Name

You can enter the name of the owner and the vessel in the FMD55, so that it will appear as a footnote on every print out.

- € Press **<SETUP>** to enter **SETUP 1** menu
- € Press key No. **<2>** to enter **SETUP 2** menu
- € Press key No. **<5>** to enter **<VESSEL>** menu
- € Press key No. **<1>** to enter **<OWNER>** for name of owner.

By using the cursors **<UP>** and **<DOWN>** you can select the letter required from A to Z and hyphens as well as spaces. When the correct letter has been chosen confirm with **<ENTER>**. Mistakes can be deleted with the **<CLEAR>** key. When all the letters of the owner's name are correctly input they entered into the memory store by pressing **<EXIT>**. You are now back in the **<VESSEL** menu, now

- € Press key No. **<1>** to enter **<SHIP>** mode in order to enter the name of the vessel in the same way as the owner's name has been entered.

8.3. Switching On and Setting Timer

The timer functions and the automatic return to the basic standby mode as well as the regulation of the back-lit display can be selected.

8.3.1. Switching Timer ON and OFF

Sometimes it is necessary to switch the timer off for a short time without losing the stored data.

€ Press **<SETUP>** to enter SETUP 1 menu

€ Press key No. **<2>** to enter SETUP 2 menu

€ Press key No. **<6>** to enter **<TIMER>** menu

The cursor can now be switched either On or OFF by pressing **<YES>** or **<NO>**.

€ Press the **<EXIT>** key thrice (3 x) to return to the basic standby mode.

8.3.2. Automatic Return to Standby Mode

The FMD55 can only receive NAVTEX automatically while in the standby mode. In order to prevent that through inadvertent pressing of a key the FMD55 cannot return automatically to standby for NAVTEX reception, the FMD55 has a function, which switches itself back after 60 minutes, if no further key has been pressed.

However, should for some reason, e.g. NATEX reception is carried out by another unit, it is possible to switch this function off.

€ Press **<SETUP>** to enter SETUP 1 menu

€ Press key No. **<2>** to enter **<SETUP 2>** menu

€ Press key No. **<6>** to enter **<TIMER>** menu

€ Press **<DOWN>** to move the cursor onto **<TIMEOUT>** and by using the cursors **<YES>** and **<NO>** switch ON or OFF the automatic return to standby.

€ Press **<EXIT>** 3 x to return to the basic standby mode,

8.3.3. Controlling The LCD Display Lighting

The back-lit display normally switches on when the timer mode is automatically activated. This can, in some cases, be distracting at night. For this reason we have installed a function, which can be switched on or off by the user.

- € Press **<SETUP>** to enter menu SETUP 1
- € Press key No. **<2>** to enter **<SETUP 2>** menu
- € Press key No. **<6>** to enter **<TIMER>** menu
- € Press **<DOWN>** twice to enter **<LIGHT-ON>** menu
You can now choose whether to have the display back lit by pressing **<YES>** or not by pressing **<NO>**
- € Press **<EXIT>** three times to return to the basic standby mode.

You can however switch the lighting on during a timer function by pressing the **<DISPLAY>** key

8.4. Printing Out System Data

The following system data can be printed out:

- € Navigation log ON/OFF and by ON the trigger parameters
- € Automatic return to standby mode (timeout) ON/OFF.
- € Display back-lighting in timer mode ON/OFF.
- € Memory storage 01 to 30 (receiver and decoder settings)
- € Timer function ON/OFF
- € Timer programmes 1 to 9
- € Footnote:- Name of vessel, owner, and software version.

To activate the print out:

- € Press **<SETUP>** to enter the SETUP 1 menu
- € Press key No. **<2>** to enter SETUP 2 menu
- € Press key No. **<7>** to enter **<INFO>**.

All the system parameters will now be printed out in an orderly list.

The NAVTEX parameters must be printed out separately in the NAVTEX menu (see Ch. 5.8.)

Storing of data:

All stored data, such as system parameters, receiver parameters, timer status, stored messages etc. remain stored for at least 3 months, and under optimal conditions up to 12 months. This is possible because of the integrated NiCd battery, which is continually charged when the unit is in operation.

It is recommended that in a case, where the unit should be out of operation for a longer period, that you print out the system data and the NAVTEX parameters and file them. Should there be a loss of data, you can re-enter the old data from the print out.

8.5. Deletion of Memory Store and RESET

All programmed system parameter data can be deleted i.e. can be reset to the standard parameters. Equally, all stored messages can be deleted. In this case the programmed timer status, navigation log status and NAVTEX parameters will also be deleted. It is therefore recommended, that you print out the system and NAVTEX status, **before** you commence this function (see chapters 8.4. and 5.8.)

To activate the deletion function:

1. switch off the unit by turning **<OFF>**
2. press and hold key **<CLEAR>** and
3. switch unit back on
4. release the **<CLEAR>** key briefly and
5. repress **<CLEAR>**

9. Installation

9.1. Delivery Contents

As well as the FMD55 the following material necessary for the mounting are supplies in the packing:

€ 1 pc	pre-assembled power connection cable
€ 2 pcs	universal mounting brackets
€ 4 pcs	self holding spacers
€ 4 pcs	lock washers M5
€ 4 pcs	thumb screws M5
€ 4 pcs	caps for unused screw-holes
€ 1 pc	spare fuse 2A slow-blow 5 x 20mm
€ 1 pc	fuse, 500mA slow-blow 5 x 20mm (active antenna)
€ 1 pc	mounting hole template
€ 1 pc	instruction manual
€ 1 pc	screwdriver 2mm for contrast adjustment

9.2. Installation of the Unit

The two universal mounting brackets allow:

- € Desk top fitting
- € wall fitting
- € ceiling fitting

Additionally the FMD55 can be fitted at 4 different angles. Screw the brackets with the 4 screws to the wall or ceiling, using the adhesive template in order to bore the holes in the correct positions.

On each side of the FMD55, there are four M5 threaded holes for fitting at the required angle with the thumbscrews. Beforehand, press the self-holding spacers into the selected holes. These keep the brackets at a defined distance from the casing and has been accounted for in the template.

Before boring the holes, we recommend you to attach the brackets, power supply and antenna cables, and select the final mounting position.

Using the template bore the holes in the exact positions and screw on the brackets. Hold the FMD55 at the selected angle and attach with the thumbscrews into the holes with the spacers.

Place the black plastic caps supplied in the spare screw-holes.

Various mounting positions

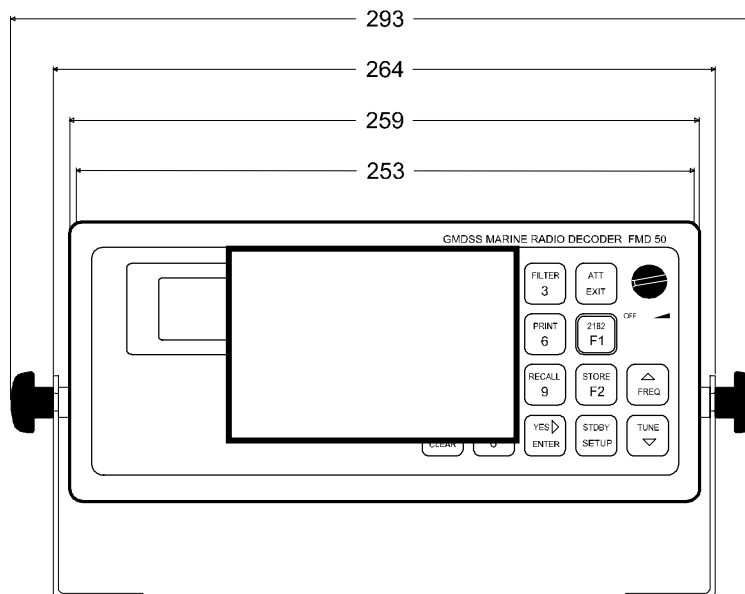
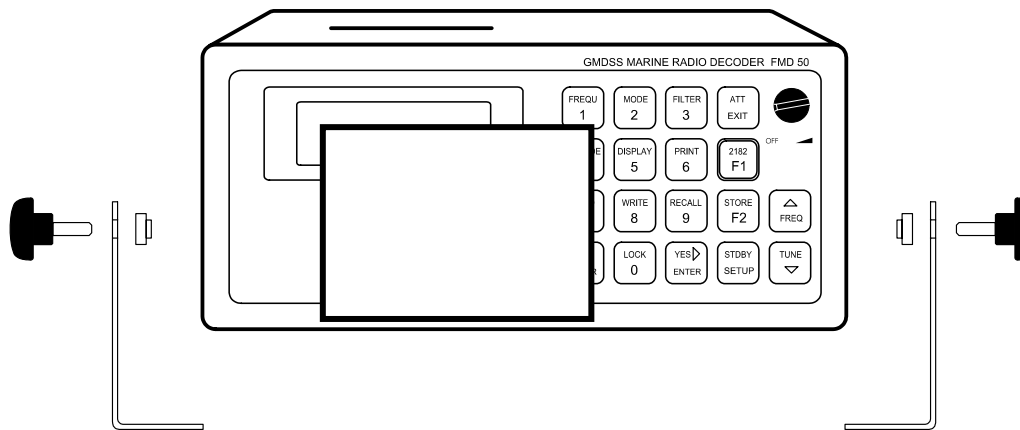

Desk top fitting

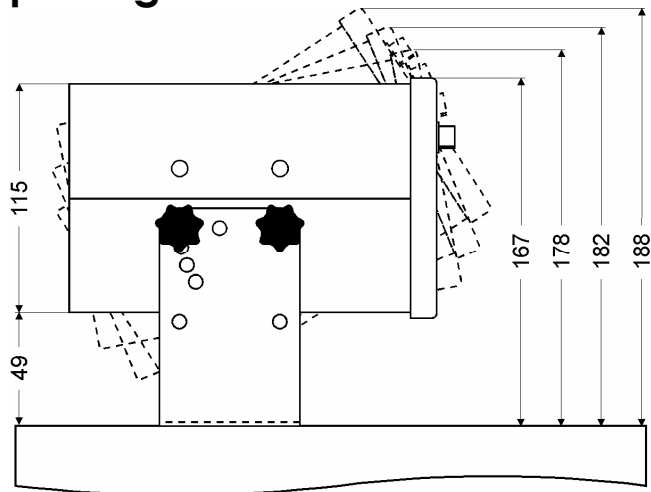

Ceiling fitting

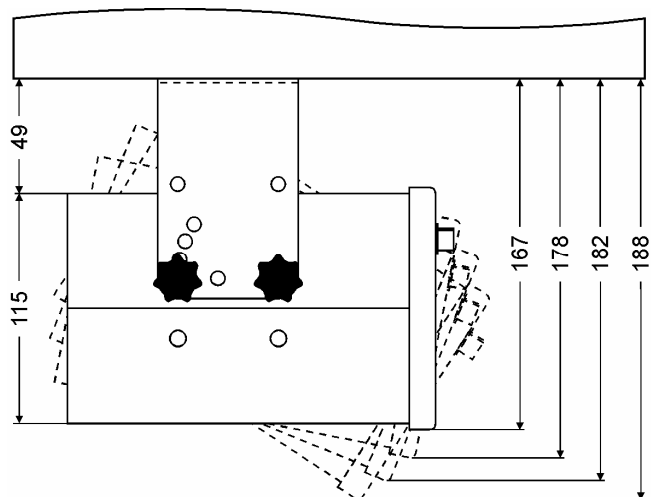

Wall fitting

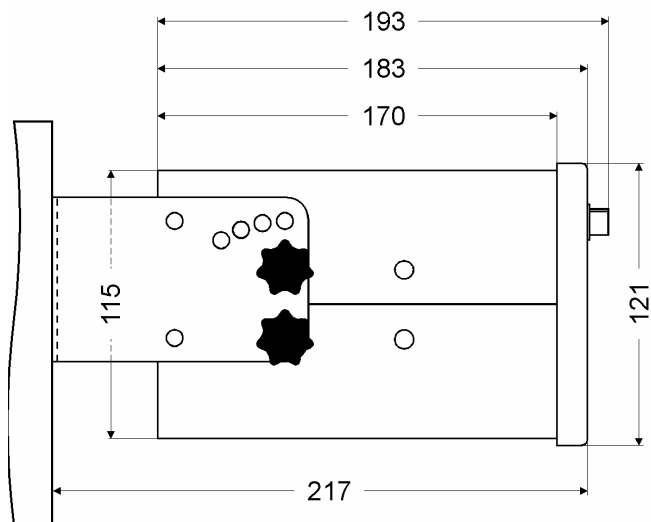

9.3. Reverse Side View

Connection for optional printer
or RS232 printer M50-ETP

Connection for NMEA input e.g. GPS

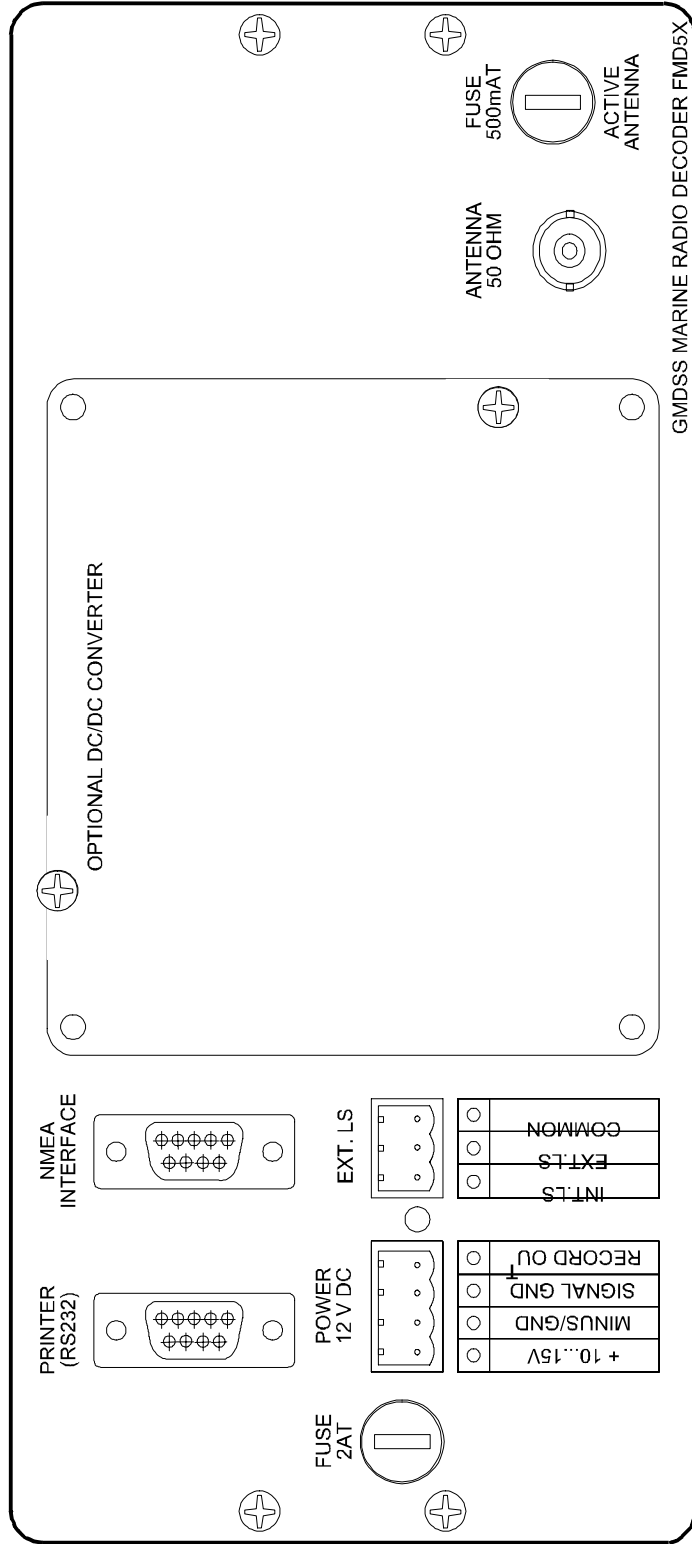

External loudspeaker (optional)

Power, audio signal output

Fuse 2A slow-blow

50 antenna connection

9.4. Power Supply Connection

Plug the pre-assembled cable supplied into the socket at the rear. The clip on connection is self-locking, however for safety reasons it is advisable to secure with the pre-set screws. The earth wire (yellow/green) must be screwed to the GROUND connection.

The unit was manufactured to operate on a supply voltage of 11V to 15V DC (12V battery). The FMD55 has reverse battery and over voltage protection. Should an incorrect connection take place, check the fuse and if necessary, replace.

The power cable is shielded to suppress disturbances. The open end is ready for connection and is fitted with a terminal strip. The connection should be as near as possible to the distribution panel or the battery. It is most important, that the current is completely free of interference. Should there be any doubt, we recommend, that you fit a suppression filter.

Fit the cable as follows:

€ brown :(-) minus pole 12volt battery
€ white :(+) plus pole 12 volt battery
€ yellow/green : earth (ground plate)

Before switching on, we recommend you to test the polarity and the voltage at the terminals on the unit.

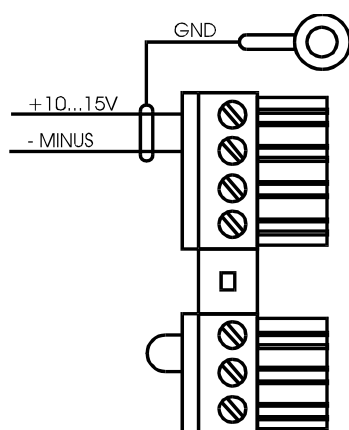

9.5. Record Out- Tape Deck, PC etc.

The receiver has a LF output with a drive level for a tape deck (approx. 200mVss) coming out of the REC OUT connection on the reverse of the unit. It is possible here to connect an external tape deck or amplifier.

Let the necessary connections be done by an expert. The input of incorrect voltages, or if the signal level is too high, could lead to the destruction of the FMD55.

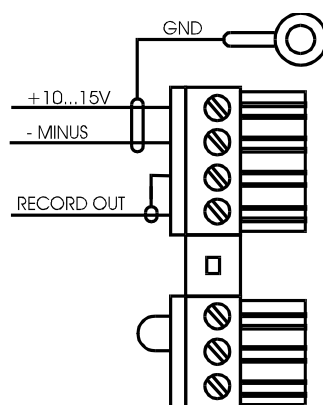

9.6. Connecting External Loudspeaker

An external speaker can be connected to the three-point connection. In this case remove the factory produced bridge and connect as follows:

a) internal speaker only

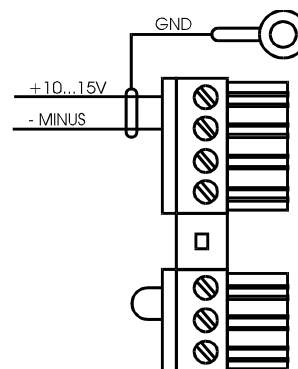

b) internal and external speakers

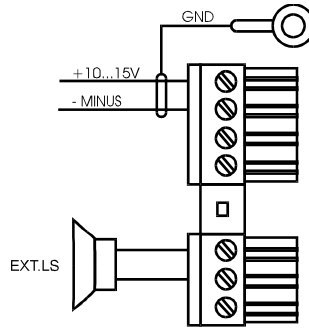

c) external speakers only

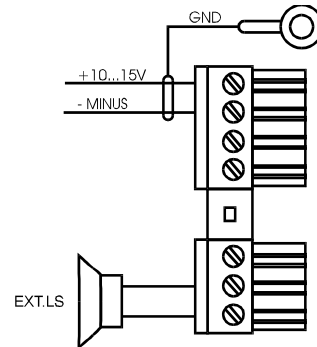

9.7. Antenna Connection and Earthing

The antenna socket is designed to be fitted to a coaxial cable connection with a BNC plug and impedance of 50Ω. No provision has been made for the connection of high impedance, unshielded antennæ.

The reception quality depends, to a high degree, on the quality of the antenna used. A good antenna guarantees good reception.

We recommend the use of a well-tuned passive antenna or a high performance active antenna. Cheap active antennæ do not provide the desired results due to bad cross-modulation characteristics.

Long wire antenna (e.g. on the back-stay) should be used in connection with an impedance matching balun transformer.

Important for good reception is of course good earthing of the ship's power supply and the FMD55. An adequately dimensioned grounding sponge and properly matched antenna will result in optimum performance.

For installation recommendations, see the following pages:

9.8. Connecting An Active Antenna

The FMD55 is prepared for the supply of an active antenna with 12V DC max. and approx. 300mA. This however not activated on delivery. On the output of the antenna there would be a constant 12 V and on connecting a balun transformer, the power would be short circuited.

In order to activate the power supply you must insert the glass fuse supplied (500 map slow-blow).

For this you must unscrew the four screws on the side, and remove the half-casing containing the loudspeaker. To do this, pull out the casing about 5mm and lift carefully. Pull out the connection for the speaker. Insert the fuse in holder found next to the antenna connection. Place the half-casing back in its original position and reconnect the antenna socket. Now replace the casing under the front frame as withdrawn so that the screw-holes are exactly conforming and screw together.

From now on there is a voltage of 12 V on the internal conductor of the antenna socket.

For antenna installation suggestions please see the next three pages

Long-wire Antenna (MLB) and Whip Antenna

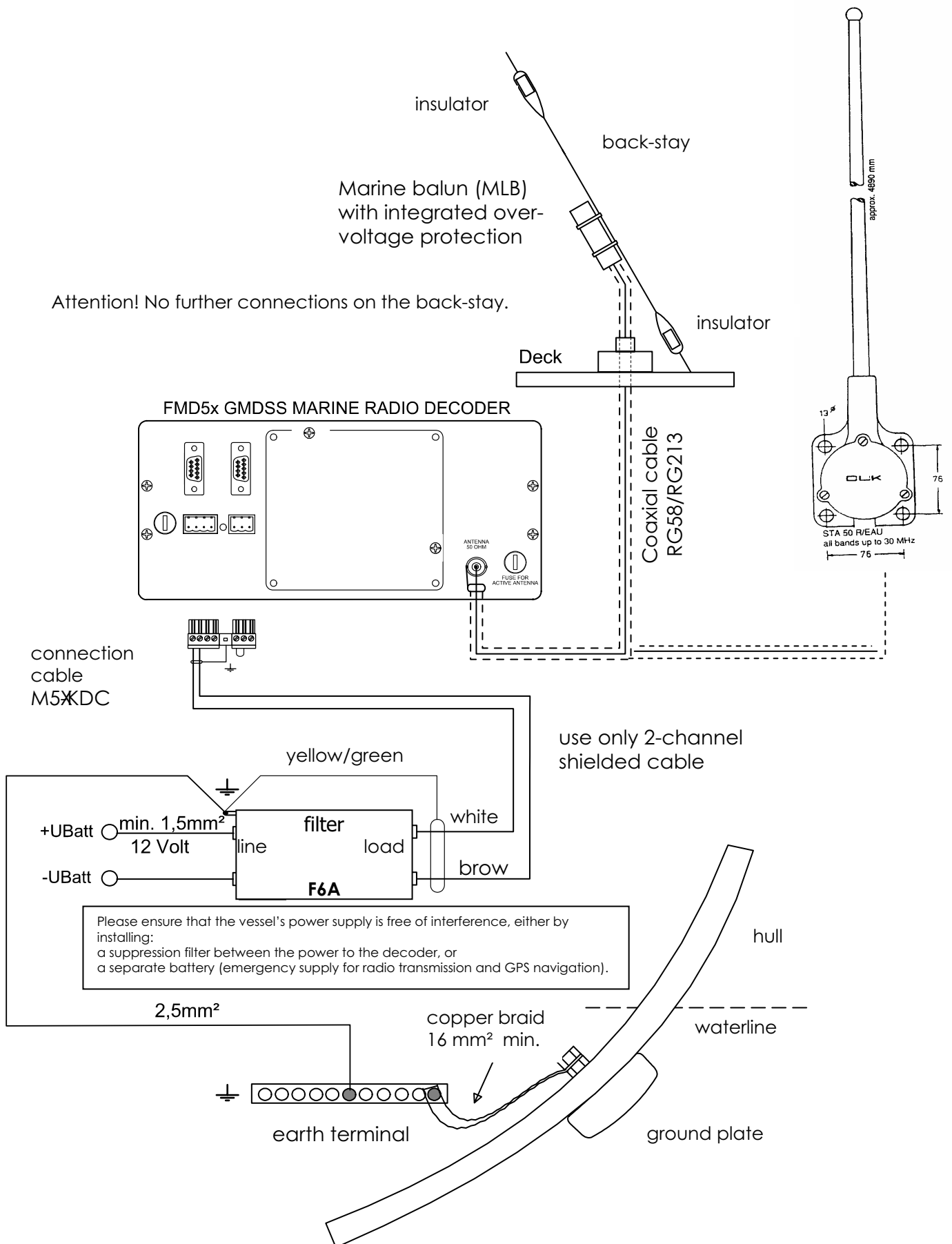

Active Antenna MD-AA

active antenna **MD-AA**

Antenna **must be earthed**. Mounting tube **must be connected** to the vessel's ground plate.

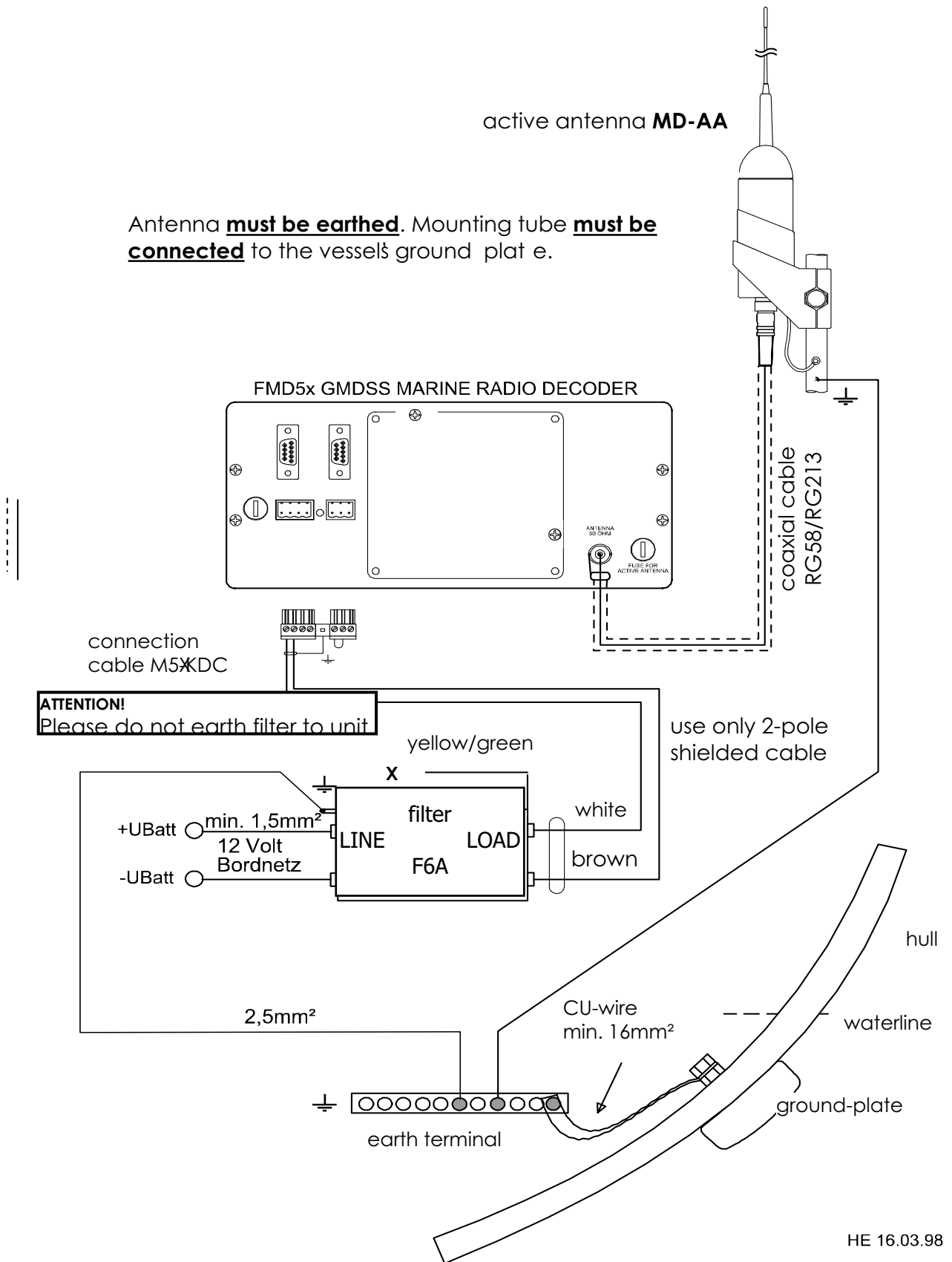

Active Antenna – R + R

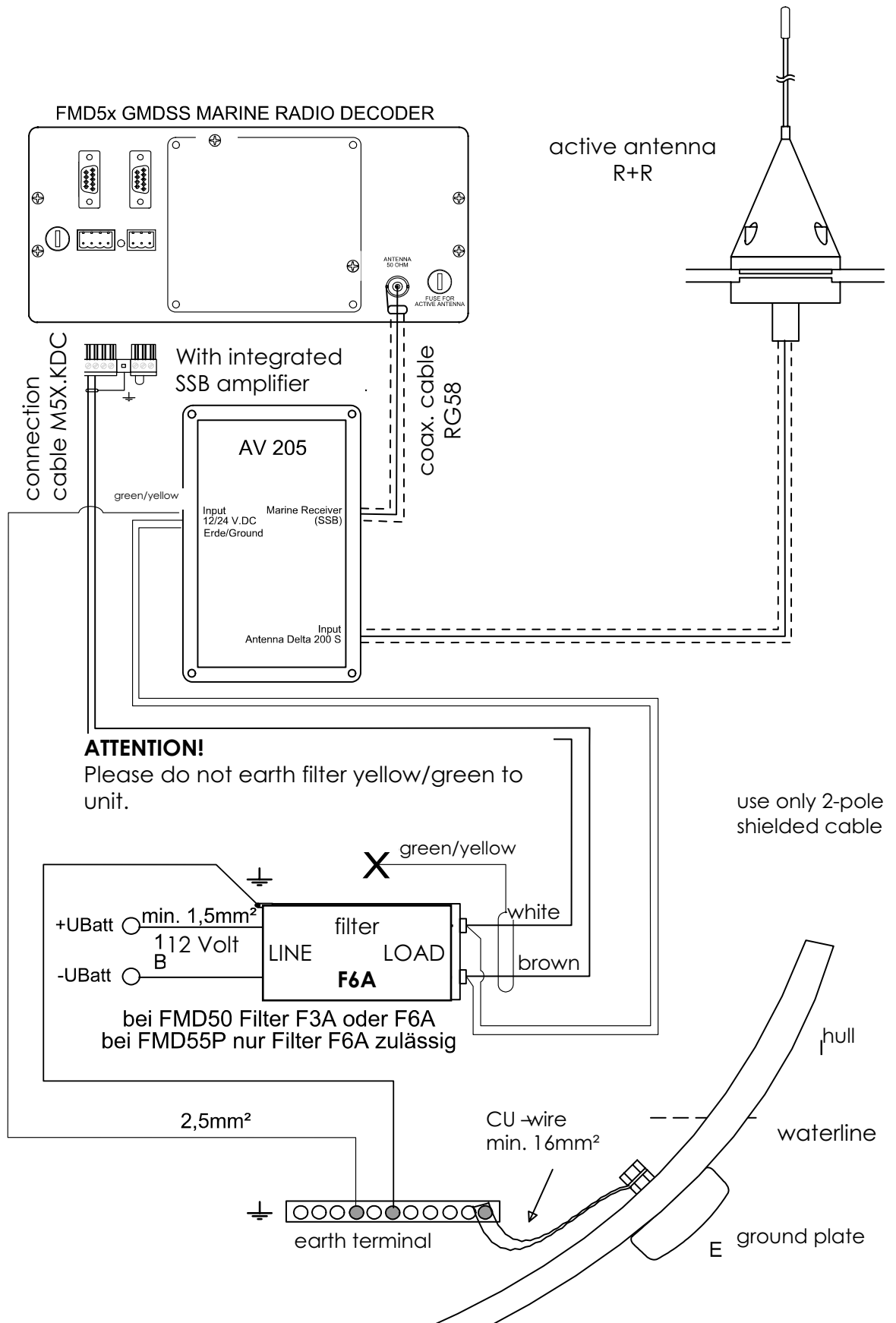

9.12. Printer paper change

The FMD55 has a thermal printer, paper width: 112mm. The diameter of the paper roll must not exceed 45mm and the diameter of the core, no more than 12.5mm. The standard supplied roll has an approximate length of 25 metres and prior to reaching the end, a colour indication will appear, reminding you to change the roll.

Changing the roll:

1. Switch the unit off
2. Remove paper roll lid (2 thumb screws).
3. Lift the pressure lever (90° to the casing)
4. Pull the old roll and core rod upwards to remove, making sure that there are no paper remains left in the mechanism!
5. Stick the core rod through the new roll and replace in the holder.
6. Cut the end of the paper roll as in sketch

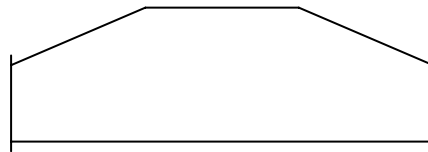

7. Feed the paper through the guide until the paper appears at the tear-off blade.
Straighten the paper by pulling parallel.
8. Pull the paper at both ends so that it is parallel.
9. Replace pressure lever.
10. Replace the lid.
11. Switch unit on and make a print out (stored message) to see if the printer is working properly.

9.13. Connection for RS232 Interface

The FMD55 has also an RS232 interface, on which a serial external printer or a p.c. system can be connected for printing out or processing stored data respectively. (See also Ch. 4.5.)

Decode or stored data can be transported to a PC for further processing. The output happens analogue to the internal printer print out. Should the print out of the internal printer not function simultaneously then connect pins 5 and 8 together

The following programmes are suited for data processing:

- ∄ Windows Terminal programme
- ∄ Norton Commander
- ∄ XTalk for Microstuff

The Baud rate at the interface is 9600 Bd. This means that any printer with a serial interface with 9600 Bd and F~~8~~0 emulation can be connected. Character length 8 bit, zero parity bit, one stop bit. Plug assignment - see the next diagram.

9.14 Connection for NMEA Interface

When the FMD55 is to be used as a navigation log or an NMEA printer, an NMEA unit e.g. GPS, must be connected. The connections T~~X~~/- of the NMEA external unit must be connected with the R~~X~~/- of the FMD55. The T~~X~~/- of the FMD55 are not active and are only for factory tests.

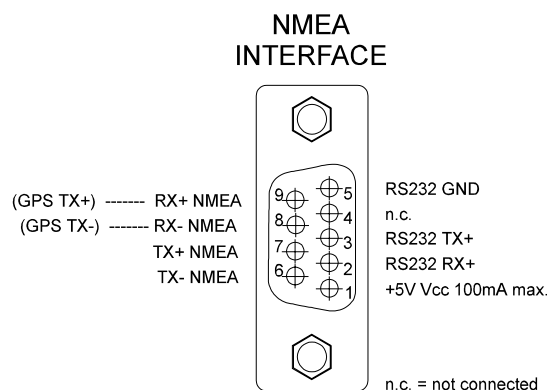

9.15. Remote Control Output (Optional)

The FMD55 can be supplied with an output for control from an external relay. The control output works parallel to the backlighting of the display. This switches off automatically in the stand-by mode and, depending on the setting, switches on automatically in the timer mode.

9.16. Adjusting Contrast of LCD Display

The contrast of LCDs is generally dependant on temperature fluctuation. The FMD55 has an integrated compensator, which, through a wide range in temperature, enables a rich in contrast display. However during a greater fluctuation it is sometimes necessary to adjust slightly. Before adjusting, the unit should have completed the warming up phase i.e. working for about one or two hours. Adjust, using the screwdriver supplied, the small screw to the right and above the volume control knob.

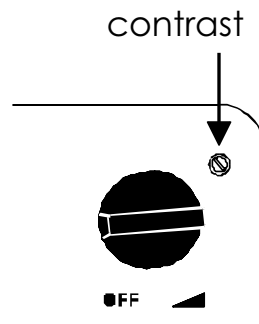

10. Accessories

10.1. 24 V DC/DC Converter

The FMD55 can be operated with a DC/DC converter. This offers the following advantages:

- € input voltage range 9V to 36V
- € constant output voltage 12.5V

This means that the FMD55 can be operated by 12V and 24V batteries. The DC/DC converter has an integrated filter, which suppresses interference from the ship's voltage supply and offers additionally, a galvanic separation between the power supply and the unit. (An advantage for aluminium hulls).

Two versions can be supplied:

- a) **M5X-DC** DC/DC converter for FMD55 and FMD55P, which is fitted directly on the reverse side of the unit
- b) **DC936-12** DC/DC converter in a separate casing. This unit can be installed near the unit

Both converters have integrated IN/OUT filters to suppress noise and ray interference.

10.2. DC936-12 DC/DC Converter for 9V – 36V DC to 12V DC

With the DC/DC converter, DC936-12, it is possible to operate electronic 12V nominal voltage devices with a 24V on board network. Vice versa, with the 936-24, a 24V a unit can be operated with a 12V network. The maximum power consumption of the unit connected can be as high as 30 Watt.

By an input voltage from 9V to 36V, the output voltage will be constant. The input and output voltages are galvanically separated. The efficiency is between 75 and 82%, depending on the fluctuation of load. Special filters have been integrated at input and output, to suppress noise voltage and radiation interference and which guarantee interference free operation of connected devices and from the onboard network. We recommend that you use shielded cables for input and output. For this reason, an earth connection has been provided for at both terminals.

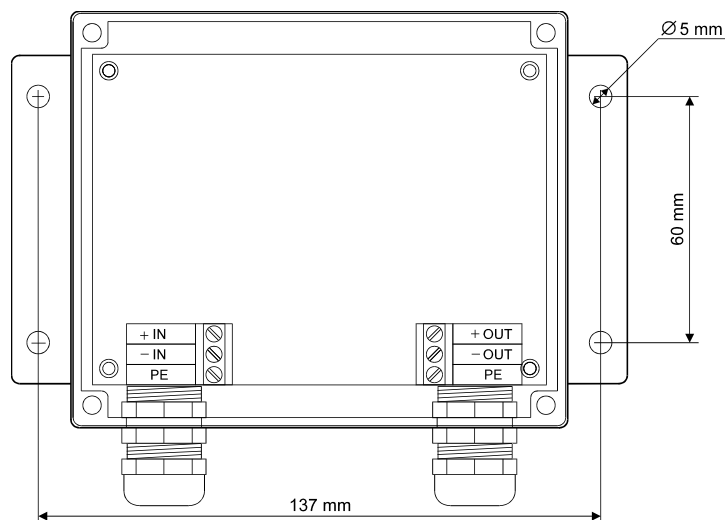

Technical Information:

Dimensions: (L150 x W102 x H36) mm

Connections: terminal screws / PG 11

Input voltage: 9 to 36 volt DC

Type: DC936-12: 12 volt output voltage

Max. output current 2.5 amp.

Type: DC936-24: 24 volt output voltage

Max. output current 1.25 amp.

10.3. Installation of M5X-DC Converter

All material for the installation will be supplied.

1. Screw the M3 x 5 mm distance bolts using the spacers into the pre-prepared screw-holes on the reverse of the FMD55.

ATTENTION: Do not turn with too much momentum otherwise the threaded stems may break-off

2. Screw on the DC/DC converter with the M3 x 35 mm screws and spacers on to the distance bolts.
3. Attach the connection cable of the converter to the power supply of the FMD55 and screw tight.
4. Plug the original FMD connection cable into the converter and screw tight.
5. Connect the connection cable to the power supply and the FMD55 is ready to work.

10.5. MLB Long-wire Balun Transformer for Back-stay

The function of the MLB is to match impedance of the high Ohm long-wire stay antenna with the 50 Ω antenna input. The balun is connected to the antenna input with a shielded 50 Ω coaxial cable. This leads the antenna signal to the receiver input but not the noise voltage interference. This results in a vital improvement in the quality of reception.

With its special matching transformer, it enables you to use an insulated stay, with a length between 6 and 25 metres, as an antenna for a reception range from 100kHz to 30MHz.

An over-voltage protection against electrostatic charging during lightning storms has been built in.

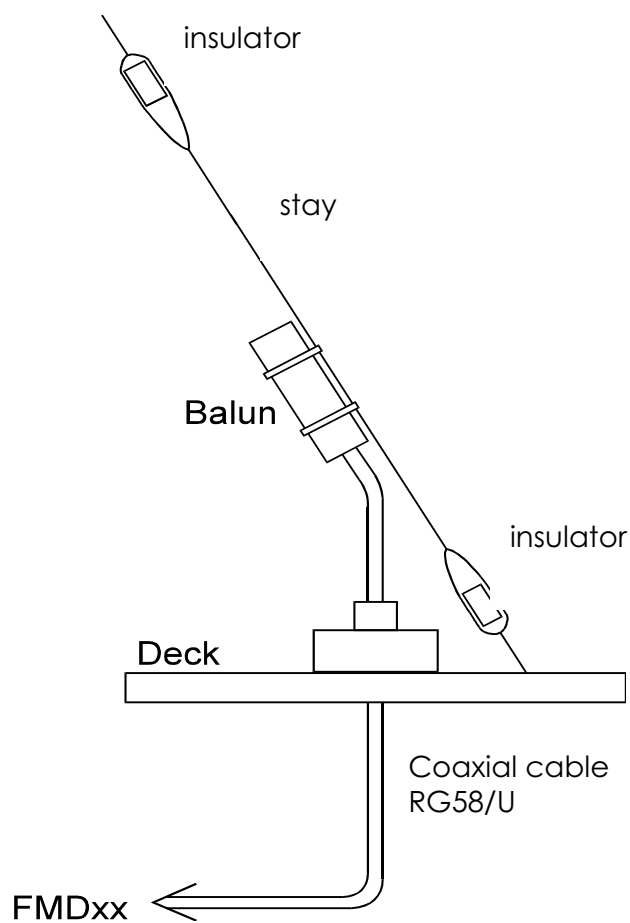

Order information: MLB marine long-wire balun transformer

10.6. F6A Suppression Filter

Practically every piece of electrical or electronic equipment on board, which is connected to the vessel's power supply, such as the generator, the battery charger, pumps, refrigerator etc., cause disturbances within the power supply. This could interfere with the function of sensitive electronic equipment, such as a receiver.

This filter suppresses a great deal of such disturbance, which may reach the decoder via the power supply. It can be simply fitted between the power supply and the unit.

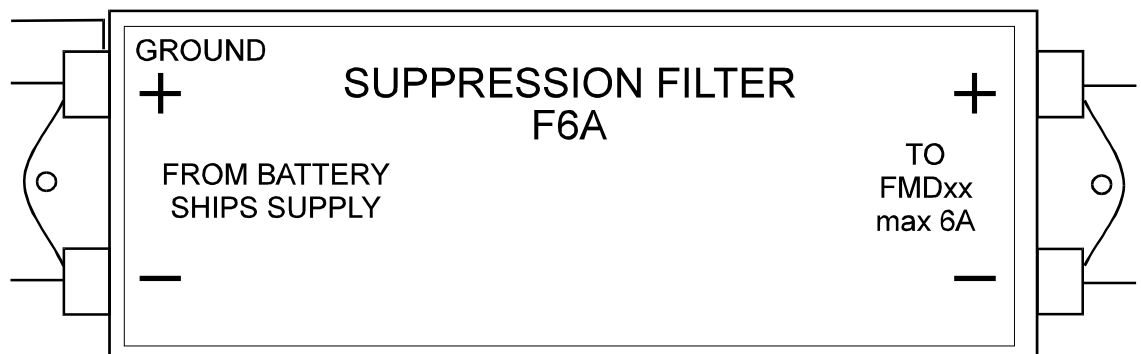

Order information: F6A suppression filter 6A

10.7. Connection Cable for NMEA Interface

For FMD55 NMEA-printer and navigation log functions.

For the connection of external units such as GPS with NMEA output, Mark4 Inmarsat-E EPIRB or DAS30 Inmarsat-E EPIRB.

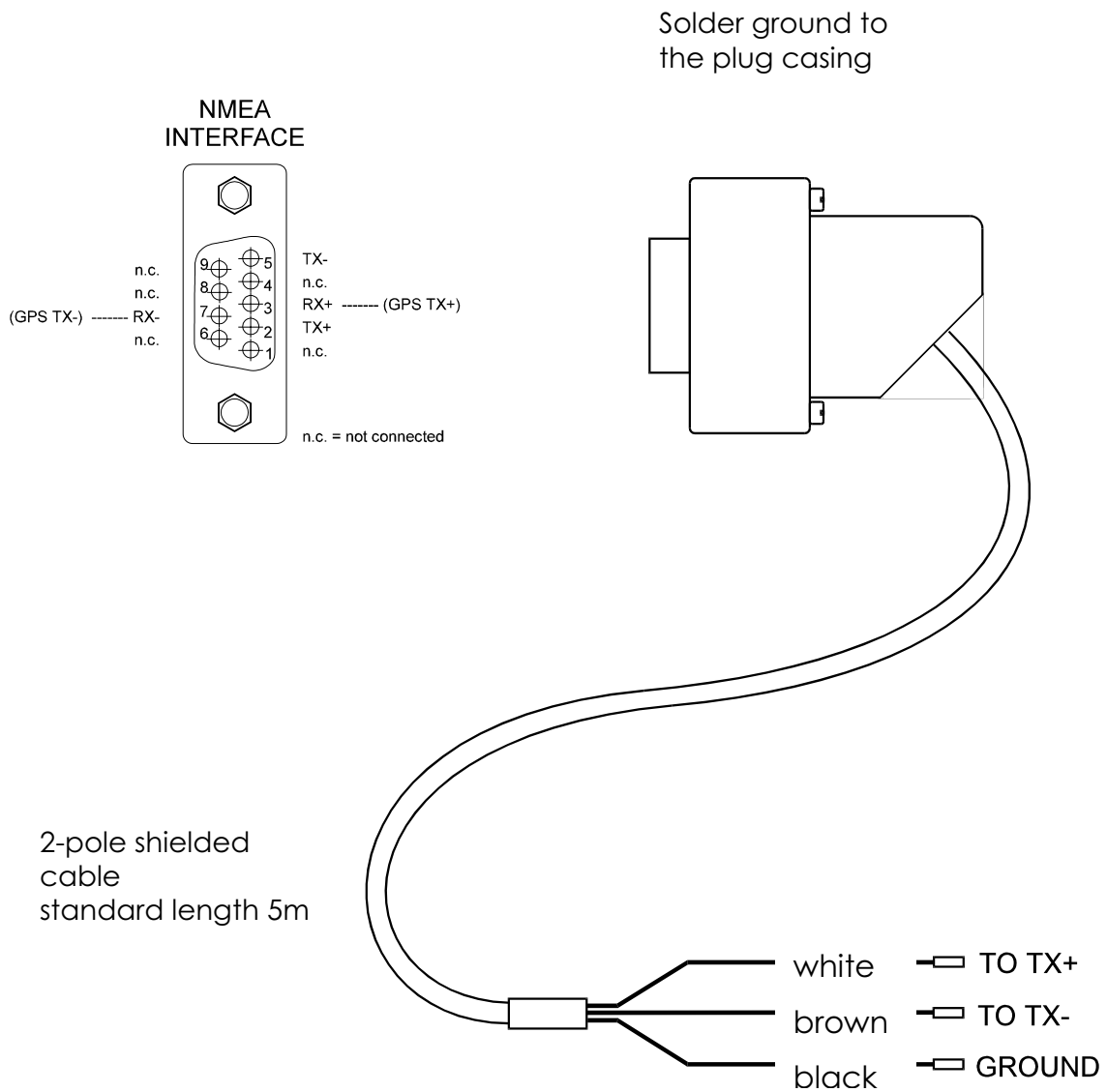

Order information: M50-KGL NMEA connection cable for FMD55

11. Technical Data

11.1. General

Dimensions:	253(Width) x 115(Height) x 180(Depth) mm
Overall	: 300(Width) x 120(Height) x 230(Depth) mm
Weight	: without printer : approx. 2.3 kg
	: with printer : approx. 2.8 kg
Power supply	: nom. 12 volt (11 to 15 volt) DC
With DC/DC converter	: 9 to 36 volt DC
Consumption (12volt)	: approx. 300mA in standby
	: approx. 450mA operating
	: approx. 1.2A when printing
Consumption (12 volt)	: approx. 350mA in standby
(with DC/DC conv.)	: approx. 500mA operating
	: approx. 1.3A when printing
Consumption (24 volt)	: approx. 200mA in standby
(with DC/DC conv.)	: approx. 300mA operating
	: approx. 700mA when printing

11.2. Receiver General

Frequency range	: 30 kHz to 30 MHz VF variable
Modulation	: AM, CW, FSK(LSB), USB
Tuning	: micro-processor controlled PLL synthesiser
Receiver	: double super heterodyne receiver with PLL synthesiser tuning
Interval Frequency 1	: 44.999 to 45.000 MHz
	IF 2 :455 kHz
Pre-selection	: modulation in 6 ranges
1.	500 kHz
2.	500 kHz to 1.7 MHz
3.	1.7 MHz to 4.2 MHz
4.	4.2 MHz to 10 MHz
5.	10 MHz to 19 MHz
6.	19 MHz to 30 MHz
Display	: integrated LCD panel displaying
	- frequency in 7 digits resolution 10Hz
	- modes AM, CW, FSK, USB
	- field strength (bar graph) ▶
	- memory location
	- band-width 0.5,2.2,4,7 and 10 kHz
	- attenuation-20dB ON/OFF

Tuning	: keypad input - 1 kHz resolution
Fine tuning	: UP/DOWN keys approx. 10kHz steps
Memory storage	: 30 frequencies incl., all parameters, and modes can be stored and recalled for read out and print out.
IF filter	: AM -4 kHz, 7 kHz, 10 kHz : FSK, USB -2. 2 kHz : CW -2 .2 kHz
Audio filter	: LF filter 500Hz width with 1500 Hz Centre frequency for CW and FSK
Antenna impedance	: 50 Ω asym., BNC connector
Outputs	: record output approx. 350 mV External speaker

11.3. Receiver Features

Sensitivity measurements in σ V PD across the antenna input at 50 Ω impedance. AM and SSB sensitivity determined at signal to noise ratio of 10 dB at receiver output:

AM signal : carrier modulated 70% and 1 kHz

SSB signal : carrier de-modulated, resolved

	at 1 kHz
60 kHz to 2 MHz	: AM - 1.2 σ V, typical 0.8 σ V : SSB - 0.6 σ V, typical 0.4 σ V
2 MHz to 30 MHz	: AM - 0.9 σ V, typical 0.6 σ V : SSB - 0.5 σ V, typical 0.3 σ V

Selectivity	IF filter	band-width kHz			shape factor
	KHz	-6 dB	-60 dB	-80 dB	SF6:60dB
	2.2	2.3	3.4	5.5	1:1.5
	4.0	5.9	9.8	10.7	1:1.7
	7.0	8.8	12.9	14.6	1:1.5
	10.0	10.5	21.5		1:2.0

SSB carrier de-modulation (2.2kHz CF) 20 dB

CW filter position : (to carrier frequency)

-6 dB point at -0.8 kHz and +1.35 kHz

LF frequency 1500 Hz to carrier frequency

500 Hz filter : centre by 1500 Hz

Band-width : 500 Hz at 3 dB

: 1000 Hz at -10 dB

Dynamic range reciprocal switcher effect: (2.2 kHz IF filter)

↳ 80dB by signal distance 5kHz

↳ 90dB by signal distance 10kHz

↳ 105dB by signal distance 100kHz

Frequency drift (typical values -not guaranteed)

At 20°C constant : drift +/- 30 Hz/hour

: frequency error +/- 50 Hz

by +15°C to +50°C : frequency error +/- 200Hz

LF audio output: : 1.6 W on 8T by 5%HD by 12V.

: 2 W on 4T by 5%HD by 12 volt

: external speaker impedance 4 T

RECORD OUT : 350 to 400 mV out of 5 kT

11.4. Micro-controller – Signal processor

processor : SAB80C517A Siemens

programme memory : 128K x 8 EPROM

memory store : 128K x 8 SRAM

system clock : 15.360 MHz

signal processor : ADSP-2105KP analogue device

filter : PEB2060P Siemens

memory store : 15000 NAVTEX + 32000 others

11.5. LCD Display

type : DMF5001NYL-EB Optrex

display field : 101 x 82 mm

resolution : 160 x 128 dots

characters / line : 20

lines : 16

lighting : luminescent foil

11.6. Thermal Printer

type : LTP5446B-C382 Seiko

mechanism : thermal

resolution : 8 dots per mm

max. dots/line : 832

speed : 25 mm per second

paper width : 112 mm

print width : 104 mm

head life : 5 x 10⁷ characters
approx. 30 km text

11.7. Barograph

sensor	: KPY43A Siemens
range	: 0...1.6 bar
display range	: 950...1080 hPa (mbar)
exactitude	: +/- 3 hPa (after calibration)
resolution	: 0.1 hPa

11.8. Interfaces (ext. Printer, RS232, NMEA)

a) external printer (optional)

connector	: sub min D 15 -pin
assignment	: pin-out system specific for M55-ETP only

b) NMEA interface

connector	: sub min D 9-pin
specification	: NMEA 0183
Baud rate	:4800 Bd.
Assignment	pin 2 : TX+
	pin 3 : RX +
	pin 5 : TX -
	pin 7 : RX -

c) RS232 interface

An RS232 interface, with a Baud rate of 9600 Bd., is integrated (on the same connector as the NMEA) for special purposes.

connector	: sub min D 9-pin
specification	: RS232
baud rate	: 9600 Bd
bit length	: 8 bit
bit parity	: none
stop bit	: 1 bit
data control	: busy
character sets	: IBM compatible
assignment	pin 1 : minus (ext. Printer).
	pin 2 : TX signal
	pin 3 : RX signal

pin 4 : busy
pin 5 : signal ground (RS232)
pin 7 : reset
pin 8 : internal signal
pin 9 : Ubatt 12V (ext. printer)

If there is no integrated printer connected the voltage supply for the external thermal printer M55-ETP (12V nom. 11-15V) can be placed on pins 1 + 9.

Pin 7: reset is only for M55-ETP

Pin 8: internal signal (identification of M55-ETP)

Assignment usable for customised printers only:

pin 2 : TX signal
pin 3 : RX signal
pin 4 : busy (if necessary)
pin 5 : earth (ground)

11.9. Approvals

The FMD55 has been tested by the BZT (The German Federal Institute for Telecommunication in Saarbrücken) according to the following technical requirements:

FTZ 171 R 41













FTZ 171 R 45

FTZ 171 R 46

FTZ 171 R 47

and was awarded the type approval No. A115198E -BV permitting installation on board all vessels flying under the German flag. This also meets the regulations of ISO 9000 as laid down in the Conformity Declaration. The corresponding CE is attached.

12.9 Beaufort Scale of Wind Forces

Beau- fort- Scale	Description	Average Wind Force in m/s	Average Wind Force in kn	Description in the Weather Chart
0	calm	< 0,2	< 1	
1	light air	0,3 - 1,5	1 - 3	
2	slight breeze	1,6 - 3,3	4 - 6	
3	gentle breeze	3,4 - 5,4	7 - 10	
4	moderate breeze	5,5 - 7,9	11 - 15	
5	fresh breeze	8,0 - 10,7	16 - 21	
6	strong breeze	10,8 - 13,8	22 - 27	
7	moderate gale	13,9 - 17,1	28 - 33	
8	fresh gale	17,2 - 20,7	34 - 40	
9	strong gale	20,8 - 24,4	41 - 47	
10	whole gale	24,5 - 28,4	48 - 55	
11	storm	28,5 - 32,6	56 - 63	
12	hurricane	> 32,6	> 63	

12.11. Propagation of SW Signals

One of the questions raised frequently is to determine which transmissions can be received at what distance from the transmitter. There is a number of factors that affect Short Wave reception and distance vary greatly depending on time of day and year, sun activity and amount of traffic in a particular band. Each band has its own characteristics and as a rule of thumb one could say the higher the frequency, the higher the distance, at least during day time. At night there is also a considerable increase in the distance for low frequency bands. For instance, a typical transmitter in the 4 MHz band would cover a distance of 250 n.m. around noon time which would increase to as much as 2,500 n.m. at night. The following comparison looks at the various bands their respective propagation characteristics.

2 MHz Band: Maximum distance during day time is about 60 n.m. which increases at night to 200 n.m. under good conditions. Thunder storms and lightning severely affect reception quality.

4 MHz Band: Reception in this band works best in the early morning hours with a gradual decline towards noon time. Towards the evening propagation may exceed 2000 n.m.. Reception of transmitters in closer proximity may not be possible.

8 MHz Band: Best propagation during the early morning hours. Distances up to 800 n.m. should be possible during the entire day. Reception of transmitters in closer proximity may not be possible.

12 MHz Band: Until late afternoon no long distance coverage. Thereafter propagation increases gradually but transmitters located within 600 n.m. may not be received.

16 MHz Band: This band is similar to the 12 MHz band. Reception of stations within 800 n.m. is not normally possible. In the late evening hours propagation increases to 6000 n.m..

22 MHz Band: This band is not normally usable for stations located within 1000 n.m.. under good atmospheric conditions distances of up to 8000 n.m. may be covered. Best connections are obtained in North / South direction. Right after sunset this band is not usable.

12.12 Antenna Reception onboard Vessels

Radio receivers are today, standard equipment on board sea-going vessels.

In most cases it is seldom taken into account, that every receiver, no matter how expensive it is, can only function as good as its antenna.

What should one take into consideration when choosing an antenna?

- € The frequency range of the antenna must have the same range as the receiver, at least have the same range that is going to be used.
- € The output impedance of the antenna must match the input impedance of the receiver. In other words, the antenna and the receiver must conform.
- € The antenna and the cables leading to the receiver should transmit the least possible interference to the receiver. This entails proper grounding of the receiver and the antenna.

Receivers used in the maritime sector are usually 100 kHz to 30 MHz, i.e. are designed for use in the lowest LW ranges to the highest SW range. This corresponds to a wave range of approx. 3000 to 10 metres, an extremely vast range. Since the ratio of the length of an adapted antenna is always in fixed proportion to the wave-length, it is understandable that a long-wire antenna of a certain length can only be correctly adapted to one single frequency. Therefore, when using a long-wire antenna such as an insulated back-stay, it is necessary to fit between the antenna and the receiver cable, a suitable adapter. Such adapters exist (e.g. MLB marine long-wire balun), which solve the problem as adapter with a large frequency range between the long-wire and the shielded lead cable quite satisfactorily.

The antenna itself should be as high as possible and installed as far away as possible from local disturbances.

Practically every electric and electronic piece of equipment transmit interference signals which should not reach the unit via the antenna. New equipment with corresponding approvals or CE seals have been designed and constructed, free of disturbance as far as is possible. Measurements must be taken to make older units free of interference.

The lead from the antenna to the receiver must be a non-dissipative well shielded coaxial cable with the same impedance as the receiver input. These are usually laid parallel to other (disturbing) cables and near other electrical devices. A badly shielded cable picks up local interference and transmits them to the receiver.

The receiver itself should be connected at the shortest possible distance to a grounding sponge.

Alternatively an active antenna can be used. The input resistor in the amplifier of an active antenna is very high, therefore it requires a very short whip. The output resistor of the amplifier is 50Ω throughout the whole of the specified frequency range, so that a corresponding coaxial cable also with 50Ω which transmits the signal from the antenna without further loss of adaptation. The difficulty in the realisation of a good active antenna is that the integrated amplifier and the impedance transformer are as linear as possible and not over-modulated by strong signals from nearby transmitting stations creating self generated interference to the receiver. This is normally only possible with powerful amplifiers with equally high voltage use demands finding a good solution between highest possible linearity and the least amount of draw of current.

Because of the small dimensions, it is easier to find a place for mounting an active antenna away from disturbing influences. The lead to the receiver through the shielded coaxial cable is uncritical. The use of a high quality active antenna will give an optimum reception.

12.13. MORSE Code Table

The FMD50 will recognise the following code and translate accordingly:

MORSE Code	Character	Remarks
·-	A	
-···	B	
-·-·	C	
-··	D	
·	E	
··-·	F	
-·-·	G	
····	H	
··	I	
·- - -	J	
-·-	K	
····	L	
- -	M	
-·	N	
- - -	O	
·- - ·	P	
- - - ·	Q	
·- ·	R	
···	S	
-	T	
··-	U	
···-	V	
·- -	W	
- · · -	X	
- · - -	Y	
- - · ·	Z	

MORSE Code	Character	Remarks
·- - - -	1	
··- - -	2	
···- -	3	
····-	4	
·····	5	
-····	6	
- - - ···	7	
- - - ···	8	
- - - ···	9	
- - - - -	0	
·····	!	Exclamation mark
- · - - - · -)	Closing Parenthesis
- - - - · - -	(Opening Parenthesis
- · · · - ·	/	Slash
- · · · · - ·	+	Plus symbol
- - - - · · ·	:	Colon
· - · - · - ·	.	Period
- · · · - -	=	Equal symbol / new line
··- - - · ·	?	Question mark
- · · · - ·	#	Number symbol
- - - · - - -	`	Accent
· - · · · · ·	"	Quote symbol
- · · · · ·	;	Semicolon
- · · · · -	-	Minus symbol, hyphen
· - - - - · ·	'	Apostrophe

The German characters **Ä** and **Ö** are recognised as well. Other national characters or characters that cannot be identified will be shown and printed as ***or h'**

13. Examples

13.1. Station and Timer Programming - North Sea / Baltic Sea

STATUS INFORMATION

GPS-LOG : on TIME: 99min Distance: 9sm

AUTO RETURN TO NAVTEX: ON

BACKLIGHT I TIMER MODE: OFF

STORED FREQUENCY CHANNELS

CH	FREQUENCY	MODE	FILT/ATT	DEC	ME	PR	STATION
01	147.30 kHz	FSK	0.5	RTTY	W	P	Pinneberg
02	4583.00 kHz	FSK	2.2	RTTY	W		Pinneberg
03	7646.00 kHz	FSK	2.2	RTTY	W		Pinneberg
04	10100.80 kHz	FSK	2.2	RTTY	W		Pinneberg
05	14467.00 kHz	FSK	2.2	RTTY	W		Pinneberg
07	100.00 kHz	AM	7.0	AUDIO			
08	100.00 kHz	AM	7.0	AUDIO			
09	100.00 kHz	AM	7.0	AUDIO			
10	100.00 kHz	AM	7.0	AUDIO			
11	100.00 kHz	AM	7.0	AUDIO			
12	100.00 kHz	AM	7.0	AUDIO			
13	100.00 kHz	AM	7.0	AUDIO			
14	540.00 kHz	CW	0.5	MORSE	W		Tallinn
15	100.00 kHz	AM	7.0	AUDIO			
16	100.00 kHz	AM	7.0	AUDIO			
17	8417.00 kHz	FSK	2.2	SITOR	W		Portishead
18	8420.00 kHz	FSK	2.2	SITOR	W		Staint Lys
19	100.00 kHz	AM	7.0	AUDIO			
20	100.00 kHz	AM	7.0	AUDIO			
21	1269.00 kHz	AM	7.0	AUDIO			DLF
22	972.00 kHz	AM	7.0	AUDIO			NDR
23	100.00 kHz	AM	7.0	AUDIO			
24	100.00 kHz	AM	7.0	AUDIO			
25	100.00 kHz	AM	7.0	AUDIO			
26	100.00 kHz	AM	7.0	AUDIO			
27	100.00 kHz	AM	7.0	AUDIO			
28	6075.00 kHz	AM	7.0	AUDIO			Deut. Welle
29	6085.00 kHz	AM	7.0	AUDIO			DLF
30	6155.00 kHz	AM	7.0	AUDIO			R. Austria

STORED TIMER FUNCTIONS: ON

GMDSS MARINE RADIO DECODER
3.17

FMD50

Call or fax us for up to date suggestions!

13.2 Station and Timer Programming for the Med.

STATUS INFORMATION

GPS-LOG : on TIME: 99min Distance: 9sm

AUTO RETURN TO NAVTEX: ON

BACKLIGHT I TIMER MODE: ON

STORED FREQUENCY CHANNELS

CH	FREQUENCY	MODE	FILT/ATT	DEC	ME	PR	STATION
01	4583.00 kHz	FSK	2.2	RTTY	W	P	Pinneberg
02	7646.00 kHz	FSK	2.2	RTTY	W		Pinneberg
03	10100.80 kHz	FSK	2.2	RTTY	W		Pinneberg
04	4292.00 kHz	CW	0.5	MORSE	W		Roma IAR
05	100.00 kHz	AM	7.0	AUDIO			
06	6320.00 kHz	FSK	2.2	SITOR	W		Saint Lys
07	8530.00 kHz	AM	0.5	MORSE	W		Roma IAR
08	8420.00 kHz	FSK	2.2	SITOR	W		Saint Lys
09	100.00 kHz	AM	7.0	AUDIO			
10	4777.50 kHz	FSK	2.2	FAX		P	Roma
11	8146.60 kHz	FSK	2.2	FAX		P	Roma
12	100.00 kHz	AM	7.0	AUDIO			
13	4280.00 kHz	CW	0.5	MORSE	W		IDQ Roma
14	4343.00 kHz	CW	0.5	MORSE	W		Athens
15	8681.00	CW	0.5	MORSE	W		Athens
16	100.00 kHz	AM	7.0	AUDIO			
17	3650.00 kHz	FSK	2.2	FAX		P	Madrid
18	6918.50 kHz	FSK	2.2	FAX		P	Madrid
19	100.00 kHz	AM	7.0	AUDIO			
20	8331.50 kHz	FSK	2.2	FAX		P	Northwood
21	100.00 kHz	AM	7.0	AUDIO			
22	198.00 kHz	AM	7.0	AUDIO			BBC 4
23	1269.00 kHz	AM	7.0	AUDIO			DLF
24	4363.00 kHz	AM	7.0	AUDIO			Monaco
25	8728.00 kHz	AM	7.0	AUDIO			Monaco
26	2691.00 kHz	AM	7.0	AUDIO			Livorno
27	100.00 kHz	AM	7.0	AUDIO			
28	6075.00 kHz	AM	7.0	AUDIO			Deutsche Welle
29	6085.00 kHz	AM	7.0	AUDIO			DLF
30	6155.00 kHz	AM	7.0	AUDIO			Radiio Austria

STORED TIMER FUNCTIONS: ON

GMDSS MARINE RADIO DECODER

FMD50 3.17

Call or fax us for up to date suggestions!

13.3 Examples of NAVTEX and MSI Print Out

NAVTEX message - Station Wales, South Coast

WZ 899
WALES SOUTH COAST - BARRY
WELSH WATER BARRY WEST BUOY 51-22N
03-17W UNLIT
NNN
NAVTEX 518kHz SA33 12-03-94 0:53UTC

NAVTEX message - Station Split Radio

SPLITRADIO NAV WNG 243/92

SINCE DEC 16TH 1992 N OF CLIFF MULD (43
31 06 N-15 55 30 E)

ANCHORED WAVEGRAPHIC STATION MARKED
WITH W-FLASHLIGHT.

500 MTRS BERTH REQUESTED.
NNN
NAVTEX 518 kHz QA08 11-03-94 22:58UTC

MSI message - Station Meteo, France

DE METEO FRANCE
BMS ATLANTIQUE EST DU DIMANCHE
23 MAI 1993 A 1000 UTC
AVIS DE COUP DE VENT NR 588 EN COURS=
DEPRESSION 987 HPA PAR 46 NORD ET
18 OUEST LE 23 A 06 UTC
NORD OUEST VENT DE SECTEUR NORD EST
DE FORCE 8 LOCALEMENT 9

13.4 Example of Weather Report

Extract Mediterranean Sea - Station IAR Rome

06.00 GMT C.N.M.C.A-METEOMAR WEATHER FOR
ECAST OVER MEDITERRANEAN OF 06 12/07/199
3 AND VALID UP TO 18 UTC OF TODAY
1.WARNINGS: THUNDERSTORMS UNDER COURSE:
NIL. THUNDERSTORM FORECAST:OVER CENTRAL
ADRIATIC SEA-NORTHERN ADRIATIC SEA-EASTE
RN MEDITERRANEAN SEA. AEGEAN AND SOUTH
OF CRETE NECTORS GALES TYET COURSE:NIL.
GALES FORECAST:NORTHWESTERLY FORCE 7
OVER NORTHERN IONIAN SEA- SOUTHERN ADRIATIC SEA
2.WEATHER SITUATION: A COLD AND UNSTABLE
AIR STREAM OVER ADRIATIC SEA PRESSURE
FIELD OVER SEAS WEST ITALIAN PENINSULA
IS RISING A MOIST AND UNSTABLE AIR CIRCU
LATION OVER ALBORAN SEA A FRONTAL SYSTEM
OVER BALKANS IS MOVING TOWARDS THE EAST
A SEASONAL LOW PRESSURE OVER EASTERN ME
DITERRANEAN SEA.
3. FORECAST TO 18 UTC OF TODAY AND 12 HO
URS OUTLOOK. -CORSIKAN SEA-SARDINIAN SEA
NORTHWESTERLY WIND FORCE 5 ...
CH02 4292kHz MORSE + 12-07-93 7:47 UTC

Weather Report, Atlantic - Station GKA

DE GKA GKA V ATLANTIC WEATHER
STORMGENERAL SYNOPSIS=
AT 270000 UTC LOW 46 NORTH 17 WEST 996
EXPECTED. 45 NORTH 12 WEST 999 BY 240000
UTC. LOW 68 NORTH 33 WEST 1003 EX....

AREA FORECASTS FOR NEXT 24 HOURS=
BISCAY=
VARIABLE THUNDERY SHOWERS. MODERATE OR
GOOD=
TRAFALGAR=
SOUTHWESTERLY 4 OR 5. OCCASIONALLY 6 AT
FIRST NORTH

13.5 Example – Weather Chart

This chart is from Northwood but Pinneberg, Athens, Rome etc. also transmit charts several times a day.
See Admiralty List of Radio Signals NP 283 (1) and (2).

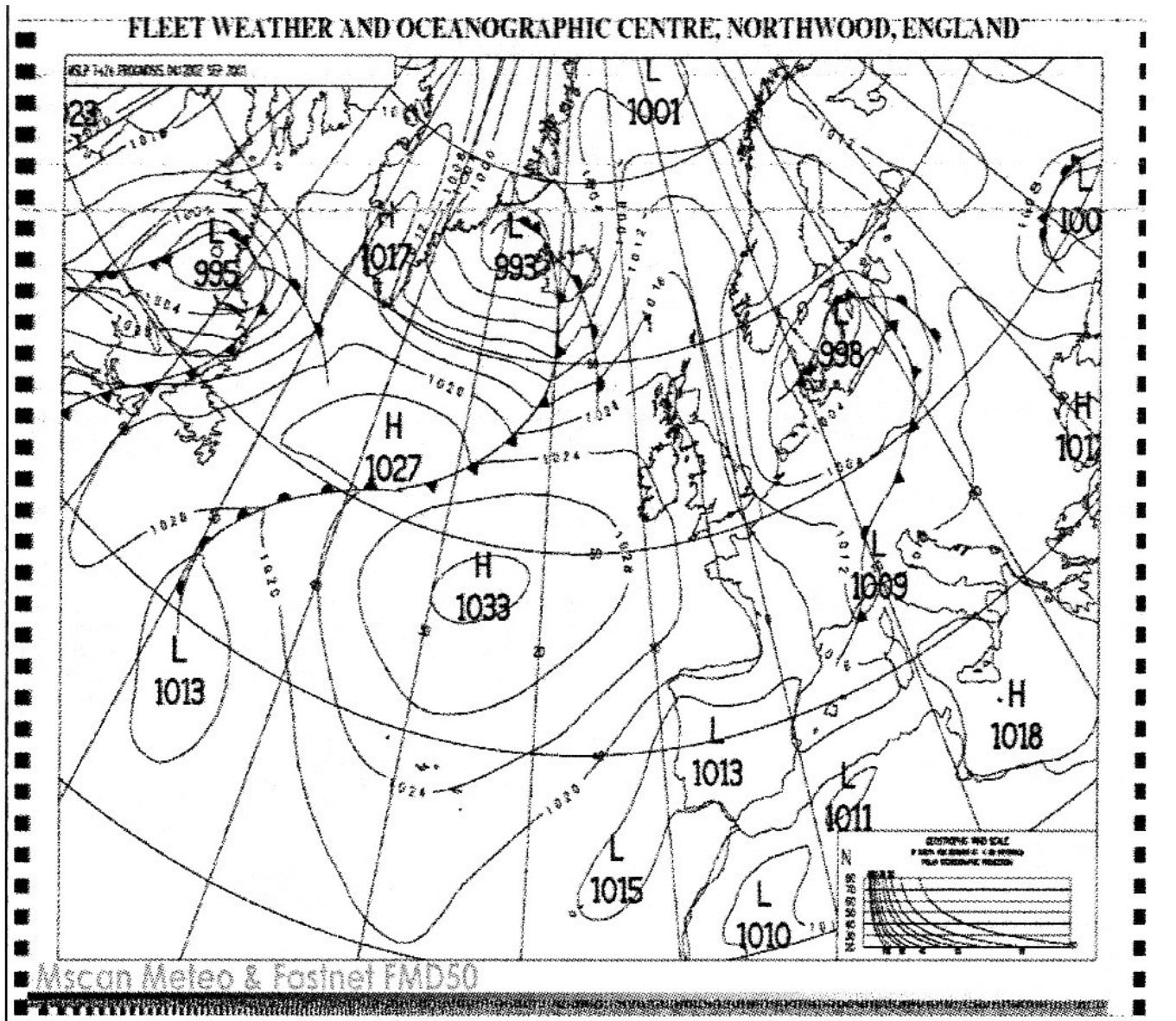

13.6. Example of Navigation Log

Navigation Log, partial print out

NAVIGATIONS LOG:131293

TIME	LAT	LONG	SPEED	COU	DATE	VAR
063046	5454.507 N	00947.122 E	00.4	137	060999	01 W
063743	5454.534 N	00946.945 E	01.0	198	060999	01 W
063945	5454.468 N	00947.084 E	00.6	113	060999	01 W
064044	5454.439 N	00947.325 E	01.7	037	060999	01 W
064544	5454.557 N	00946.951 E	00.3	051	060999	01 W
064646	5454.528 N	00947.110 E	00.4	161	060999	01 W
065243	5454.490 N	00947.107 E	00.6	183	060999	01 W
070247	5454.521 N	00947.096 E	01.3	284	060999	01 W
071238	5454.533 N	00946.976 E	00.5	346	060999	01 W
071442	5454.530 N	00947.018 E	00.5	348	060999	01 W
073118	5454.513 N	00947.082 E	00.4	290	060999	01 W
074324	5454.460 N	00946.900 E	01.0	336	060999	01 W

13.7. Example of NAVTEX Status Information

NAVTEX - STATUS - INFORMATION:

FREQUENCY: 518kHz

STATIONS: abcdefGhiJklmnOpqrSTuvwXyz

MESSAGES: ABcDEfghilkLmnopqrstuvwxyz

DIRECT PRINT: YES

REPEAT: YES

ALARM: NO

STORED MESSAGES:

GB59 GA78 GL01 GA72 GA70 GL21 GL19 GA53

GA50 TA61 TA53 TA31 TA03 TA23 SA28 SA27

SL07 SA19 SA17 SA05 SA72 SA68 SA60 SA08

SA95 GA53 SB24 OB86 SB24 SA28 SL07 SA19

SA05 SA72 SA68

GMDSS MARINE RADIO DECODER

FASTNET LADY

FMD50 2.72E

FASTNET RADIO

14. Appendix

14.1. Service and Maintenance

The FMD50 has been designed to require only a minimum of maintenance. When changing paper rolls it is advisable to check for any paper dust accumulation and remove it. There are no user serviceable parts inside the case and service should be left to qualified personnel.

14.2. Service Depots

This product has been designed and manufactured to the highest standards and has undergone rigorous testing in extreme environments. In the unlikely event that service may be required the unit should be returned to the dealer from which it was purchased. If that presents a problem then service is available from any of the following organisations:

FASTNET RADIO AG

Deelböge 5-7

22297 Hamburg

Tel.: + 49 40 369898-0

Fax: + 49 40 369898-10

e-mail: info@fastnet.de

<http://www.fastnet.de>

Kreiger GmbH

Feschnigstraße 72

A-9020 Klagenfurt

Tel.: +43 463 43390

Fax: +43 463 433904

Attention: Please return this unit to the dealer from whom it was purchased, for guarantee repairs. Whenever a unit is returned for servicing please include a complete fault description, a copy of your warranty card and / or proof of purchase.

14.4. Software Maintenance

A great number of features of this product are controlled by software which is secured in 2 EPROM firmware chips. Changes in particular requirements as well as general product improvements can therefore be updated by simply exchanging new EPROM chips against those installed. This can normally be done by a skilled technician and your dealer will gladly assist you. This manual contains a coupon for one free update. Further updates are chargeable and should be ordered through your dealer or directly from Fastnet Radio at the address mentioned above.

Up-date Enquiry :

should you have an enquiry, please fill out the attached form completely, and return it to Fastnet Radio

ENQUIRY

To
Fastnet Radio AG
Deelböge 5-7
22297 Hamburg

Subject: Software Up-date FMD55

Please send me information concerning a software up-date for the FMD50 to the following address:

Name : _____

Street : _____

Zip code/City : _____ / _____

Country : _____

Telephone : _____ - _____ - _____

Tele-fax : _____ - _____ - _____

FMD55 :Serial Number : _____

:Version Number: _____

:Date of purchase: _____

A copy of the invoice is attached :YES/NO

City,

Date

Signature

14.5. Error Alarm

The FMD20 has an integrated control function . In case of an error, an acoustic alarm will sound. This is a combination of short and long beep tones.

14.5.1. „PRINTER-ERROR“ Alarm

Should there be a fault in the printer (e.g. paper jam or end of the paper roll), the display will show “PRINTER ERROR”, at the same time an alarm will sound in the form of two short beeps. This will occur every 15 minutes.

Should the fault occur during the decoding of a message, the message will be stored automatically and after the fault has been rectified, the message can be printed out.

14.5.2 Further Acoustic Error Alarms

Nr.	Sequence Function	Explanation
01	• LCD driver	err_wait_01
12	44•• LCD driver	err_wait_2
02	4• LCD driver	err_wait_3
04	44•. LCD driver	err_wait_016
03	•• printer Function	err_prn
05	• 4 • barograph function	err_sence
14	4••• barograph function	err_baro
06	4•• receiver driver	err_init_rec
07	••• receiver driver	err_init_freq
08	444• receiver driver	err_init_dfreq
09	•44• receiver driver	err_init_mode
10	4•4• receiver driver	err_init_filter
11	••4• receiver driver	err_init_db
13	•4•• signal processor	err_fft_clr
15	•••••time, date	err_RTC
16	44444 time, date	err_RTC_set

These error alarms can happen sporadically, caused by external or internal influence such as power fluctuation, interference in the power supply, static discharge etc. They can generally be reset by pressing the <**EXIT**> key. If this does not work, switch the unit off for approx. 5 seconds.

Should this error alarm continue to occur, then most likely there is a fault in the unit and should be brought to one of the authorised service centres to be examined.