

FURUNO®

THE WORLDS OF COMPUTER
TECHNOLOGY AND
MARINE ELECTRONICS
HAVE FINALLY MERGED...
NOW IT'S TIME TO GET
PLUGGED IN!

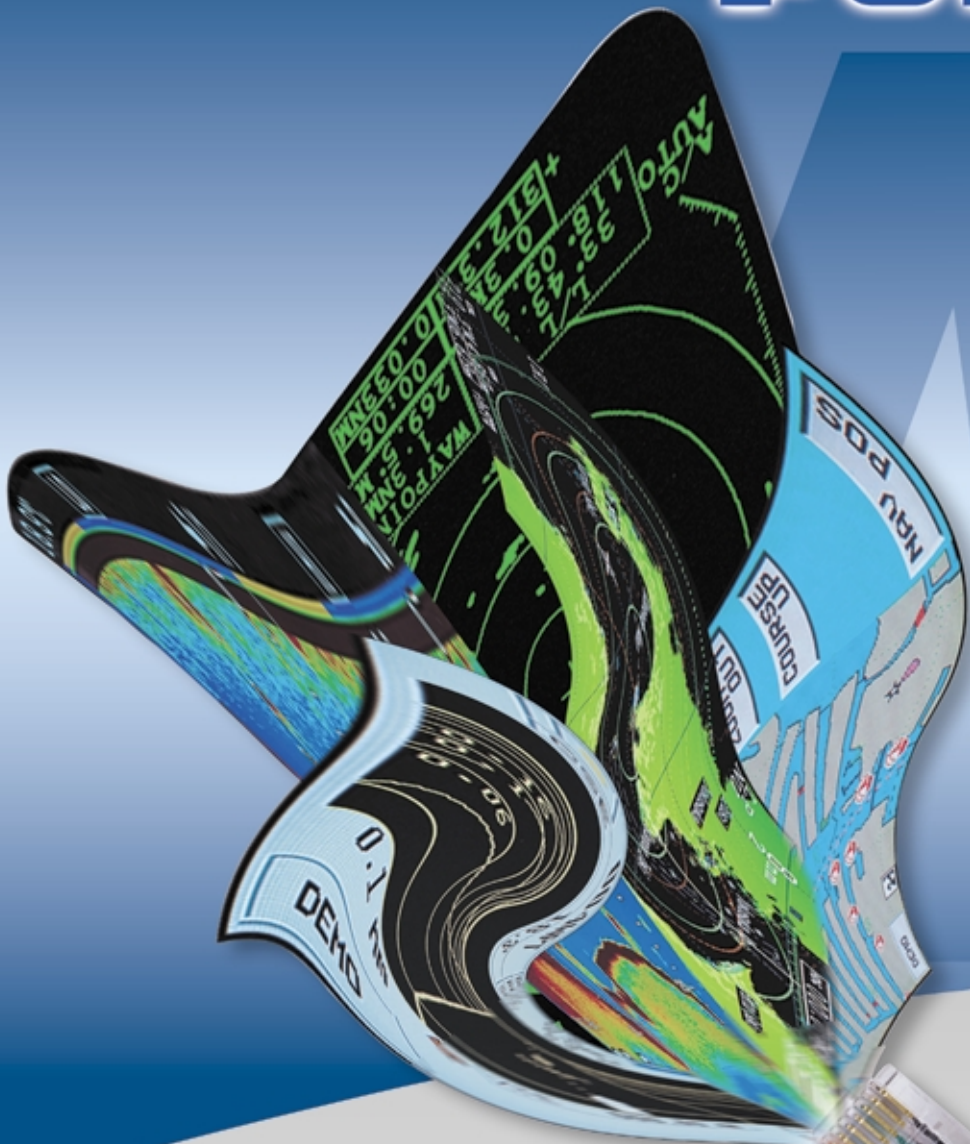

NAVnet



The future today with FURUNO's electronics technology.

FURUNO ELECTRIC CO., LTD.

9-52 Ashihara-cho, Nishinomiya City, Japan Phone: +81 (0)798 65-2111

Fax: +81 (0)798 65-4200, 66-4622 URL: www.furuno.co.jp

offered by Busse-Yachtshop.com

Catalogue No. R-180d

TRADE MARK REGISTERED
MARCA REGISTRADA



THE FUTURE OF MARINE ELECTRONICS IS HERE!

Welcome to the future of marine electronics! Introducing NavNet, Furuno's new line of Ethernet networked products. NavNet gives you the capability to communicate from one display to another over Furuno's High Speed Network.

THE **NAVnet** NETWORK

The heart of Furuno's NavNet is its Ethernet based network. Using today's technology, NavNet runs on a 10-BaseT network, which means fast data transfer between your equipment. And because Ethernet offers the option to increase speeds from 10 Megabits per second all the way to 1 Gigabit per second, NavNet's future expansion is limitless!

WHAT WILL **NAVnet** DO FOR ME?

NavNet products will allow you to customize your marine electronics according to what you need. From a standard Radar & VideoPlotter unit, you can add on a GPS, Fish Finder and even multiple displays. When multiple displays are connected, you can operate each one as an individual product or as part of the network. With more than 50 different display modes, NavNet can display the information you care the most about, the way you want to see it.

- Perfect for single or multiple display installations
- All display units are capable of controlling any component connected to the NavNet network
- Common interface on all four models of the NavNet products shortens training time
- Over 50 display modes to choose from when all components are active
- Simplified cabling requirements

THE **NAVnet** INTERFACE

Furuno's Research & Development engineers have spent countless hours making the NavNet products extremely easy and intuitive to use. The straightforward menu structure is easily selected through the softkeys and the track control ensures simple operation of the Radar, GPS VideoPlotter and Fish Finder. The controls are exactly the same from one unit to the other, so once you know one, you'll know them all.

THE **NAVnet** EXPANDABILITY FACTOR

Furuno's NavNet keeps future expansion in mind by allowing you to add on multiple units. You can turn a single display system into a multiple display system by simply adding an Ethernet Hub. The Hub will allow the products to talk to each other and share information through a simple cable. You can even connect your PC to a NavNet Display, allowing you to download or upload waypoints and routes.

NAVnet SUPPORT AND SERVICE

With Furuno sales and service centers on six continents – plus continental service centers in the United States, Denmark and Japan – the Furuno NavNet product's support and service spans the globe.

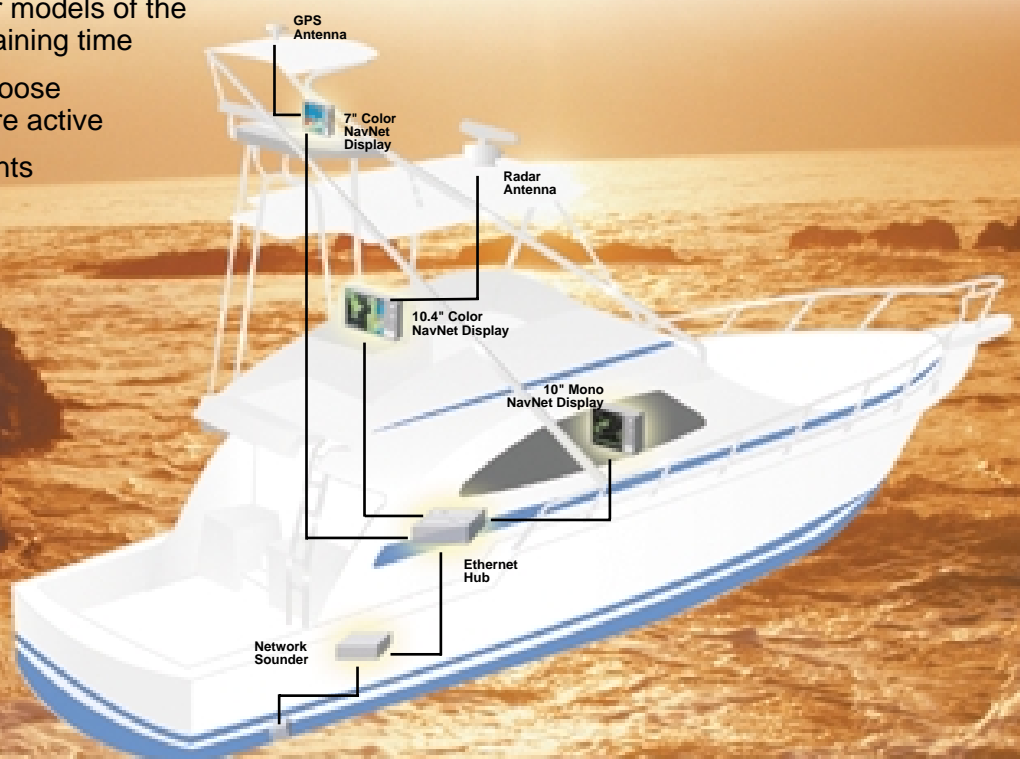

HIGH-SPEED LAN NETWORK MAKING COMPLEX INSTALLATIONS SIMPLE

A multiple of Furuno's NavNet equipment can be configured in a high-speed LAN using Ethernet. Each unit becomes a universal display, allowing you to access any component that is connected.

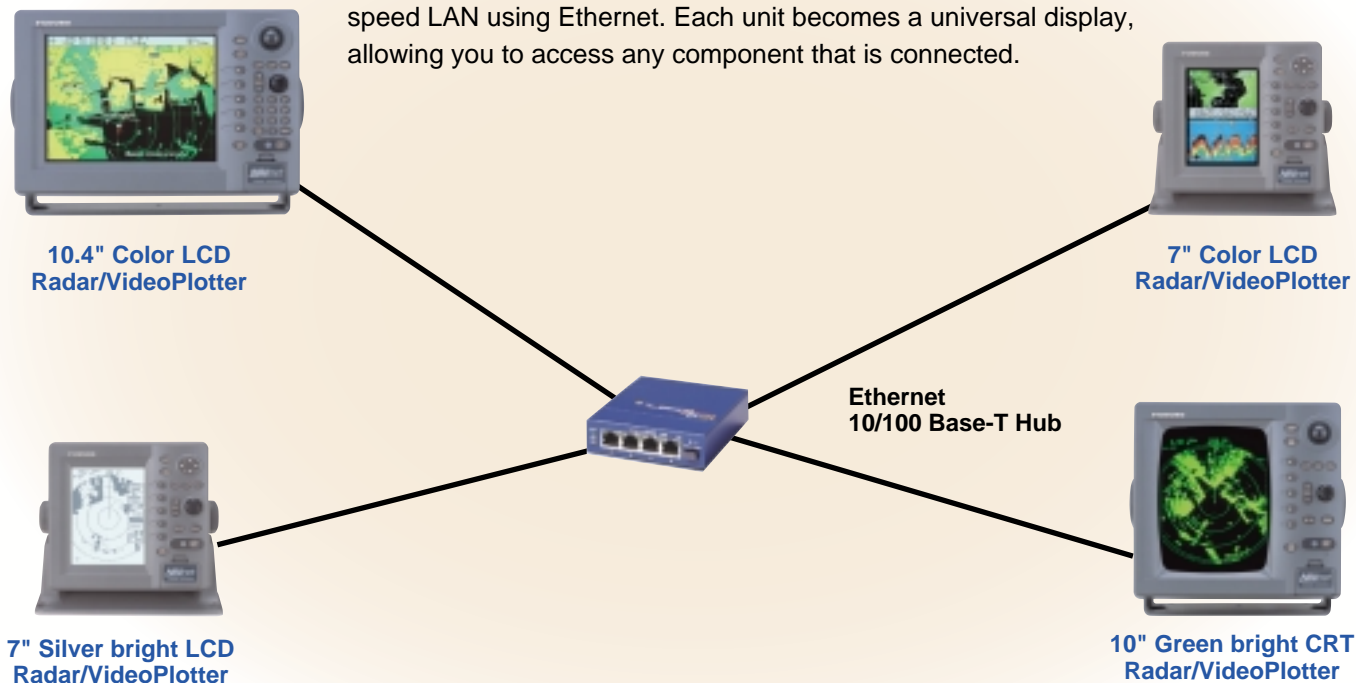

Furuno's NavNet products give you the flexibility to use them as a single, stand-alone system or as part of an integrated network bridge. Using the same network technology seen in most professional office environments, the NavNet network utilizes an Ethernet Hub, giving virtually limitless expandability.

The current network allows you to have up to four NavNet displays connected simultaneously. Add a GPS receiver antenna and a Network Sounder and you will have a complete electronics package.

But integration doesn't stop there! You can connect multiple radar and GPS antennas if needed. The NavNet network will allow you to view any component on any of the NavNet displays. So if you want to have multiple displays on one bridge or single displays throughout the vessel, you will be able to fully operate every component connected to the NavNet network.

Navigational Data Organizer Remote Display RD-30



- Optional Smart Sensor™ embodying a 235 kHz depth transducer, paddlewheel and thermosensor (0.02°F or 0.01°C resolution) is available in a variety of housings
- Excellent performance at high speed and shallow water. High frequency transducer is free from surface clutter and wakes.
- Own ship position, speed, course, water temperature, depth, speed and direction of current and wind are displayed on any display units on the network.
- No interference with most 200 kHz sounders

Color Radar / VideoPlotter

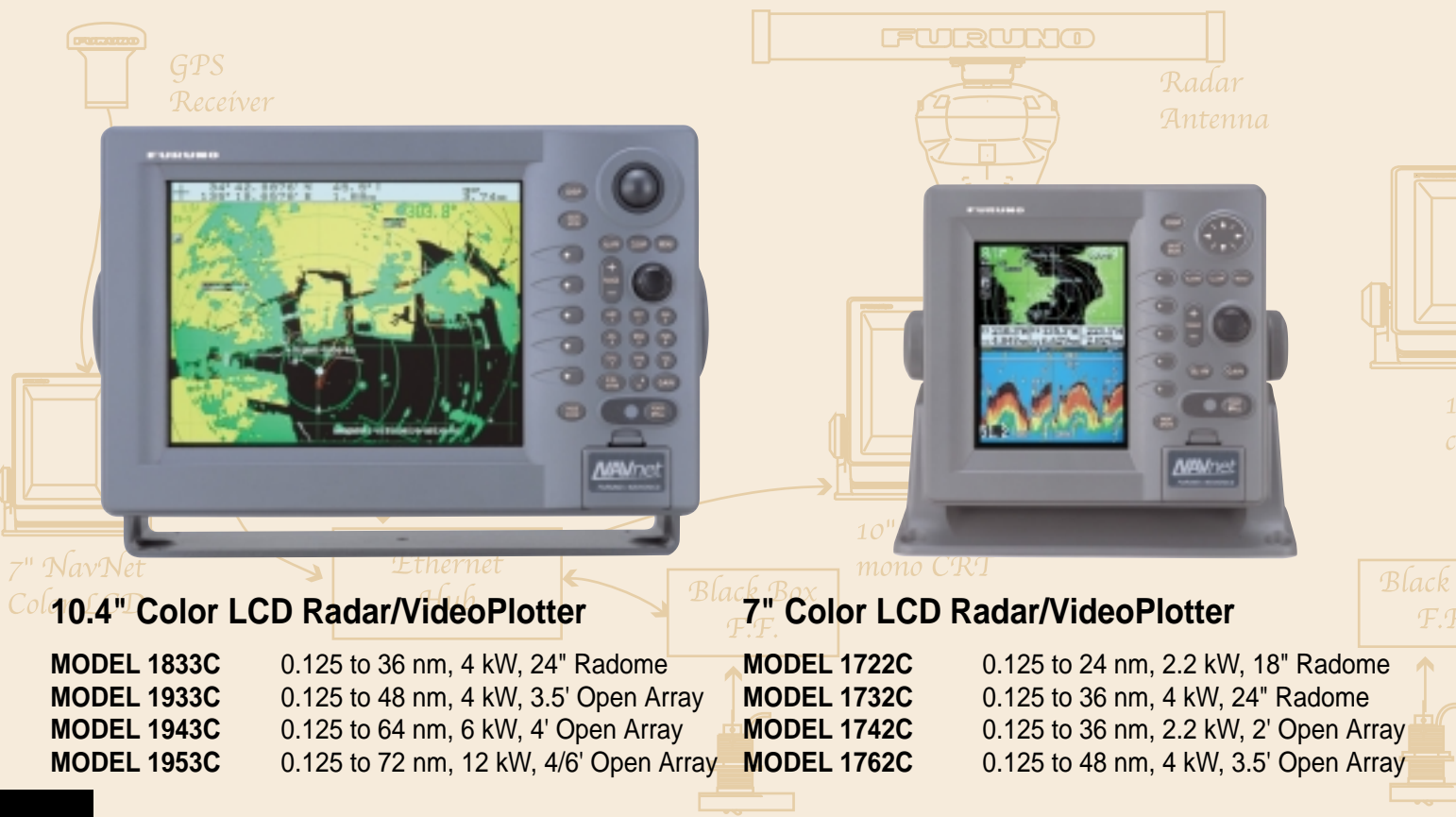

10.4" Color LCD Radar/VideoPlotter

- MODEL 1833C** 0.125 to 36 nm, 4 kW, 24" Radome
- MODEL 1933C** 0.125 to 48 nm, 4 kW, 3.5' Open Array
- MODEL 1943C** 0.125 to 64 nm, 6 kW, 4' Open Array
- MODEL 1953C** 0.125 to 72 nm, 12 kW, 4/6' Open Array

7" Color LCD Radar/VideoPlotter

- MODEL 1722C** 0.125 to 24 nm, 2.2 kW, 18" Radome
- MODEL 1732C** 0.125 to 36 nm, 4 kW, 24" Radome
- MODEL 1742C** 0.125 to 36 nm, 2.2 kW, 2' Open Array
- MODEL 1762C** 0.125 to 48 nm, 4 kW, 3.5' Open Array

When it comes to desirable features, user interface and screen definition, the 10.4" Color LCD NavNet Radar/VideoPlotter is the cream of the crop. This rugged, waterproof and compact unit offers professional features that meet the needs of serious mariners.

Furuno's 10.4" NavNet Radars were engineered around powerful X-Band transmitters that cut through all types of weather. They are packed with high-speed processors that help you identify what's out there.

As with its big brother, the 7" NavNet Displays are capable of showing a variety of displays to suit your needs. Each display comes standard as a Radar and VideoPlotter, optionally you can add a Network Sounder and GPS.

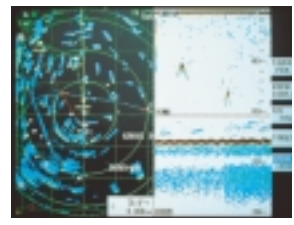

Radar/Fish Finder

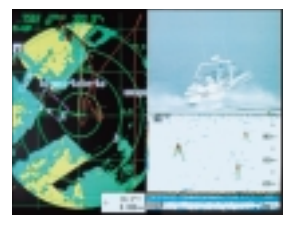

Radar Overlay/Video/Fish Finder

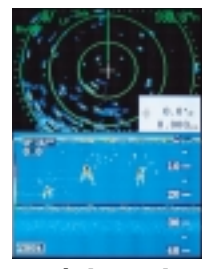

Radar/Fish Finder

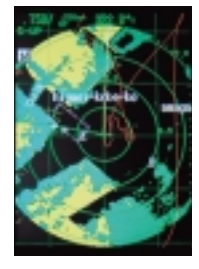

Radar Overlay*

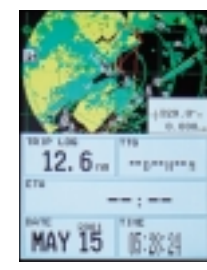

Radar Overlay*/Nav Data

*Radar overlay requires appropriate heading sensor.

NavNet Displays offer more flexibility than any other product on the market. With more than 50 possible display combinations selected through Furuno's exclusive NavNet menus, you are sure to find a display mode to suit your needs. If that weren't enough, there are five user programmable modes (six for 10.4" LCD) to allow you to customize your favorite displays with just a few key strokes.



Six User Programmable Modes (10.4" LCD model)

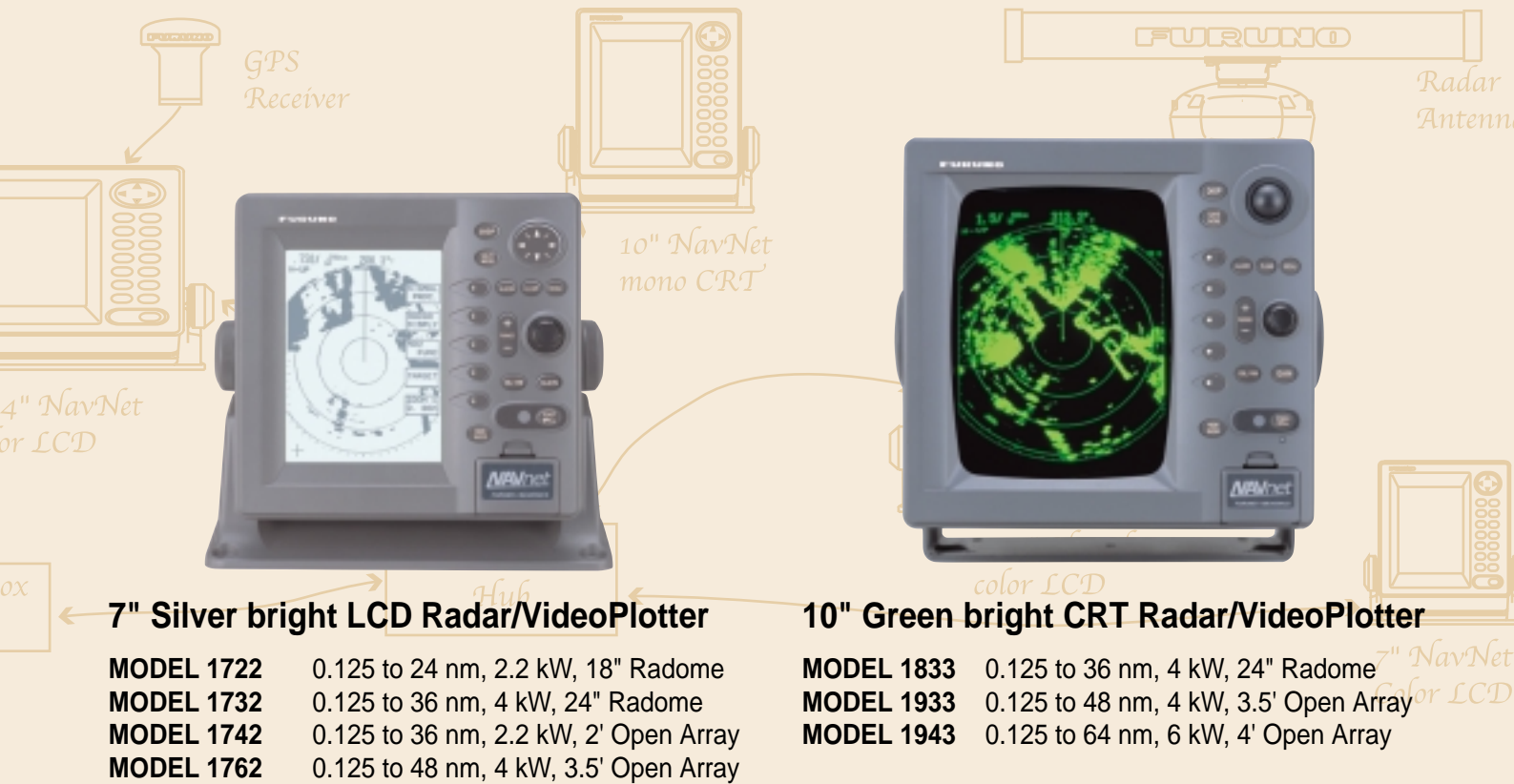

7" Silver bright LCD Radar/VideoPlotter

- MODEL 1722** 0.125 to 24 nm, 2.2 kW, 18" Radome
- MODEL 1732** 0.125 to 36 nm, 4 kW, 24" Radome
- MODEL 1742** 0.125 to 36 nm, 2.2 kW, 2' Open Array
- MODEL 1762** 0.125 to 48 nm, 4 kW, 3.5' Open Array

10" Green bright CRT Radar/VideoPlotter

- MODEL 1833** 0.125 to 36 nm, 4 kW, 24" Radome
- MODEL 1933** 0.125 to 48 nm, 4 kW, 3.5' Open Array
- MODEL 1943** 0.125 to 64 nm, 6 kW, 4' Open Array

If you want powerful, vivid performance, but don't have a lot of space, the 7" NavNet series is for you. These waterproof units are some of the most compact LCD displays we've ever offered with these features. Smaller in size, but similar in features, the 7" NavNet series has followed in its big brother's footsteps.

For those who prefer the look and feel of CRT displays, we also offer a 10" CRT NavNet display. Packed with powerful features, the 10" NavNet CRT will make an excellent choice for an enclosed bridge.



7" Mono Radar/Fish Finder



10" Mono Radar/Plotter



Each NavNet comes standard with an infrared remote control. This fully functional remote allows you to operate every mode of the NavNet unit without having to access the main display.

- Special Anti-Reflective coating on display (7" and 10.4" color LCDs only)
- Over 50 different display modes to choose from when connected with optional GPS and Network Sounder
- Choose from two units that accept either Furuno and Navionics® or C-Map^{NT} mini chart cards
- Store up to 8,000 points for ship's track and marks, 999 waypoints and 200 planned routes
- Vertical split screen allows for two display modes to be displayed simultaneously (7" LCD and 10" CRT only)
- Display VideoPlotter and Radar side by side (all units), or overlay Radar image on chart (color units only)
- Dual EBLs (Electronic Bearing Lines) and dual EVRMs (Electronic Variable Range Markers) give distance and bearing to targets
- Optional NTSC/PAL interface allows for TV/VCR/DVD video input (10.4" LCD only)
- RGB video output available on 10.4" LCD only
- Radar Guard Zone and Watchman features help to alert you to potential danger
- Four radar display modes: Head-up, North-up, Course-up and True motion

Mono Radar / VideoPlotter



**10.4" Color LCD GPS Chart/VideoPlotter
GP-1900C**

Ultra-bright picture displayed on a 10.4" color TFT LCD with wide viewing angle. Works as a Remote Radar Display like FMD-811 and FMD-8010 for an existing radar, the NavNet expansion.

**7" Color LCD GPS Chart/VideoPlotter
GP-1700C**

Vivid picture provided on a 7" color TFT LCD with wide viewing angle

- Special Anti-Reflective coating on display (7" and 10.4" color LCDs only)
- Over 50 different display modes to choose from when connected with optional Radar and Network Sounder
- Display modes in various configurations, including dual or tri-split screens
- Versatile display modes including: Course Plot, Alphanumerical Nav Data, Steering and 3-D Highway modes
- Choose from two units that accept either Furuno and Navionics® or C-MapNT mini chart cards
- Store up to 8,000 points for ship's track and marks, 1,000 waypoints and 200 planned routes
- Selectable background colors, including high-contrast white (on color displays only)
- Optional Dual-Frequency, 50 and 200 kHz, Network Sounder with selectable 600 and 1000 watts rms of output power for detailed, accurate reading of fish, bottom and structure
- Optional NTSC/PAL interface allows for TV/VCR/DVD video input (10.4" LCD only)
- RGB Video output available on 10.4" LCD only

If a GPS/VideoPlotter is what you need to complete your bridge, Furuno's NavNet GPS/VideoPlotter has all the features you are searching for in a 10.4" color or 7" color and monochrome LCD display.

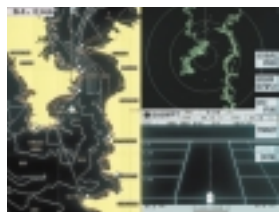

Plotter/Radar/ Highway



Nav Data/Radar/ Plotter

CARTOGRAPHY OPTIONS



Furuno's NavNet products give you the power to choose what type of charts you want to use for the plotter. You can choose from two units that accept either FURUNO CDC and Navionics® or C-MapNT mini-chart cards. Simply specify

which charting system you prefer to use when you place your order. All cards can be front loaded to allow for flush mounting of the units.

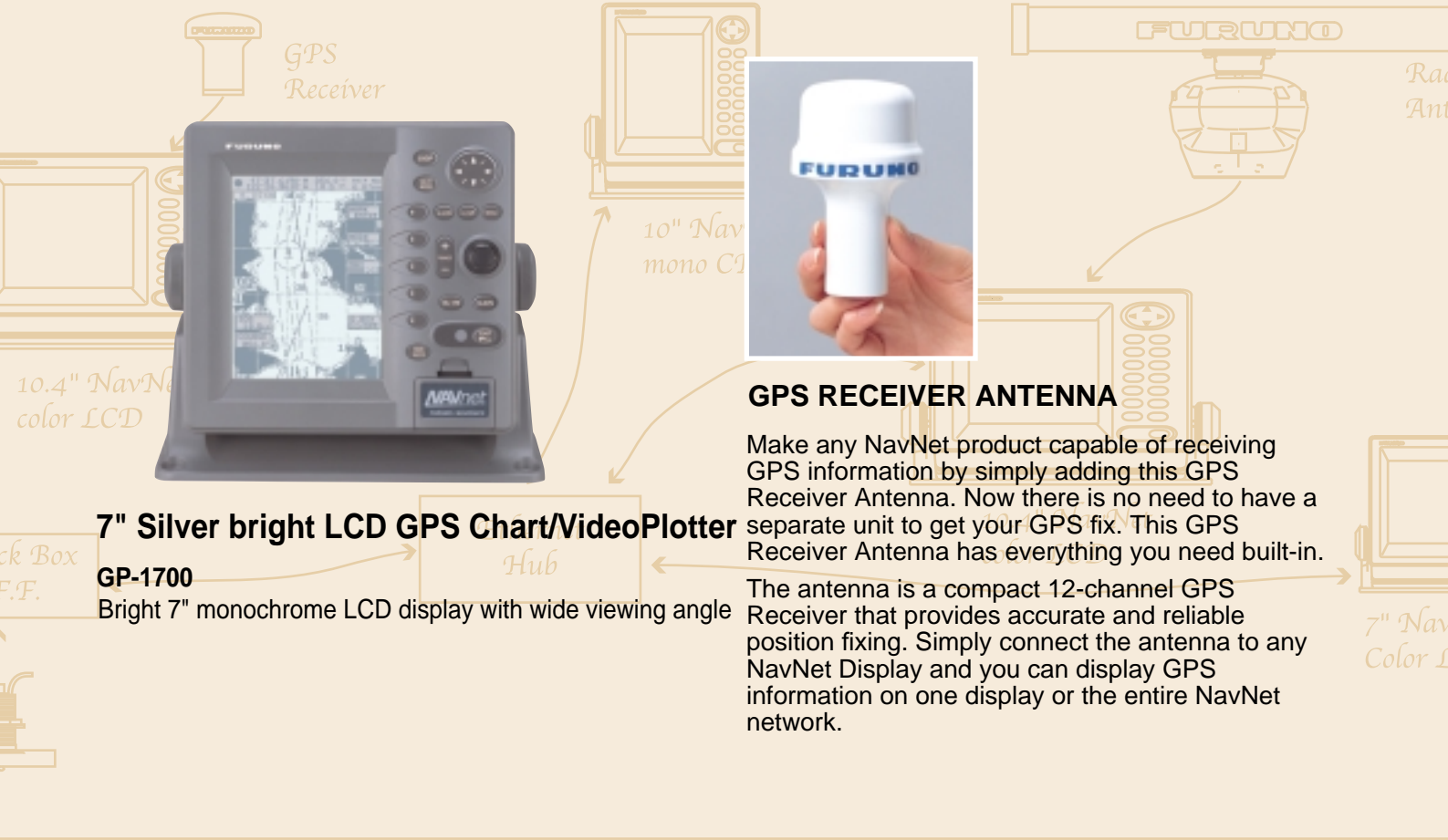

GPS RECEIVER ANTENNA

Make any NavNet product capable of receiving GPS information by simply adding this GPS Receiver Antenna. Now there is no need to have a separate unit to get your GPS fix. This GPS Receiver Antenna has everything you need built-in.

The antenna is a compact 12-channel GPS Receiver that provides accurate and reliable position fixing. Simply connect the antenna to any NavNet Display and you can display GPS information on one display or the entire NavNet network.

7" Silver bright LCD GPS Chart/VideoPlotter

GP-1700
Bright 7" monochrome LCD display with wide viewing angle

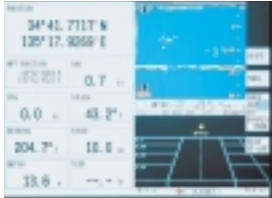

Nav Data/Fish Finder/Highway

Like the Radars, the GPS Chart/VideoPlotters are also available in the compact, waterproof 7" color or monochrome LCD displays. These units are perfect for smaller boats that are tight on space requirements, or as a second or third display.

All of the NavNet products are capable of being networked through a standard Ethernet Hub. Simply plug all of the various NavNet components into the Hub, then you can share information from one display to another.

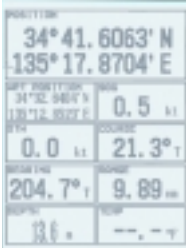

7" Mono Nav Data

USER-FRIENDLY INTERFACE

A common user interface and control panel is used on all of the NavNet products. This ensures that no matter which model you are using, when you connect another display, it will work exactly the same. The 10.4" Color LCD also comes with a bonus ten-key keypad to make entering waypoints, routes and other information even easier.

NavNet Displays offer more flexibility than any other product on the market. With more than fifty possible display combinations selected through Furuno's exclusive NavNet menus, you are sure to find a display mode to suit your needs. If that weren't enough, there are five user programmable modes to allow you to customize your favorite displays with just a few key strokes.



FURUNO MINI CHART CARD

NETWORK SOUNDER

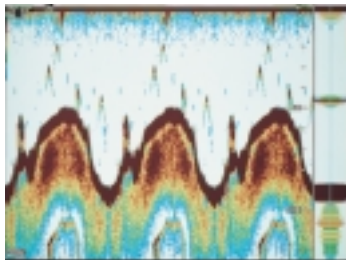

The Network Sounder is a sensor that plugs into any NavNet Display or into a Hub for multi-display installations. The sensor turns any NavNet Display into a dual-frequency 50/200 kHz, 600 W or 1 kW Sounder. It incorporates all of the award winning Furuno Sounder features you've grown to depend on, including:

- Variety of presentation modes, including marker zoom, bottom discrimination, bottom lock expansion, A-Scope and more
- Audible and adjustable depth and fish alarms
- Eight range scales to 4,000 feet
- Choice of feet, fathoms or meters
- Selectable screen background colors, including white (on color NavNet displays)
- Automatic Cruising & Fishing modes to meet your style of boating.



RADAR ANTENNA SELECTIONS

Each NavNet Radar comes with a durable Furuno antenna. The power output ranges from the sleek 2.2 kW radome, to the 12 kW open array. There is a radar and antenna type for any situation. Please reference the specifications on the back page for a complete listing of beam width, TX output power and range scales.

Network Sensors

SINGLE DISPLAY SYSTEM

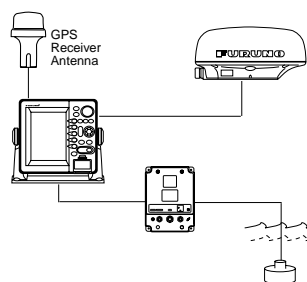

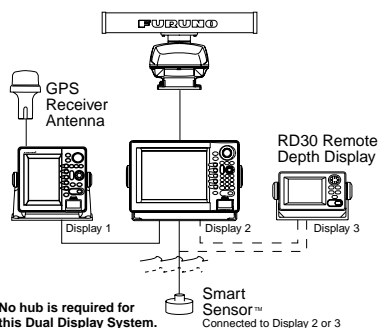

DUAL DISPLAY SYSTEM

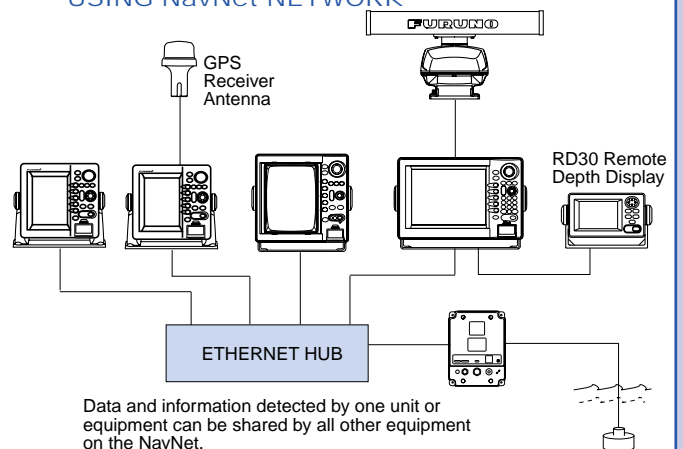

MULTIPLE DISPLAY SYSTEM USING NavNet NETWORK



SPECIFICATIONS OF NavNet SERIES

	7" Monochrome Radar / VideoPlotter				7" Color Radar / VideoPlotter			
	MODEL 1722	MODEL 1732	MODEL 1742	MODEL 1762	MODEL 1722C	MODEL 1732C	MODEL 1742C	MODEL 1762C
								
DISPLAY UNIT								
1. Type	7" Monochrome STN LCD 240 x 320 pixels				7" Color TFT LCD 232 x 320 pixels			
2. NavNet Interface	Ethernet 10-BaseT							
3. Interface (NMEA 0183 format) --: any talker (menu selection)	Input: BWC, BWR, DBK, DBS, DBT, DPT, GGA, GLL, GSV, HDT, HDM, HDG, MSS, MTW, MWV, RMA, RMB, RMC, TTM, VHW, VTG, VYW, VWT, VWR, ZDA Output: AAM, APB, BOD, BWC, BWR, DBT, DPT, GGA, GLL, GTD, MSK, MTW, RMA, RMB, RMC, TLL, VHW, VTG, WPL, XTE, ZDA							
RADAR CHARACTERISTICS								
1. Display Modes	Head-up, Course-up*, North-up*, True Motion** (* Heading input required ** Heading and speed input required)							
2. Range Scales (nm)	0.125 to 24 nm 14 steps	0.125 to 36 nm 15 steps	0.125 to 36 nm 15 steps	0.125 to 48 nm 16 steps	0.125 to 24 nm 14 steps	0.125 to 36 nm 15 steps	0.125 to 36 nm 15 steps	0.125 to 48 nm 16 steps
3. Echo Trail	Interval: 15 s, 30 s, 1 min, 3 min, 6 min, 15 min, 30 min or Continuous							
PLOTTER CHARACTERISTICS								
1. Map Scale	0.125 to 1,024 nm							
2. Latitude Limits	Between 85°N and 85°S							
3. Plot Interval	1 s to 59 min 59 s or 0.01 to 9.99 nm							
4. Display Modes	Course plot, Nav data, Steering display, Highway							
5. Presentation Modes	TM/RM North-up, Course-up, Auto Course-up							
6. Memory Capacity	Up to 8,000 points for ship's track and marks 1,000 waypoints 200 planned routes (max. 35 waypoints/route)							
7. Alarms	Arrival/anchor watch, XTE, proximity alert, ship speed, depth*, water temperature*, fish* (*Network sounder required, temperature sensor required for water temperature alarm)							
8. Electronic Charts*	Loaded from a FURUNO MiniChart, Navionics® Nav-Chart, C-MapNT chart cards * Chart must be determined upon ordering. Choice of two units: Furuno & Navionics® or C-Map							
ANTENNA RADIATOR								
1. Type	∅ 460 mm (18") Radome	∅ 602 mm (24") Radome	665 mm (2 ft) Open	1035 mm (3.5 ft) Open	∅ 460 mm (18") Radome	∅ 602 mm (24") Radome	665 mm (2 ft) Open	1035 mm (3.5 ft) Open
2. Rotation Speed	24 rpm	24 rpm	24 rpm	24 rpm	24 rpm	24 rpm	24 rpm	24 rpm
3. Wind Load	Relative 100 kt				Relative 100 kt			
4. Beamwidth	Hor: 5.2° Vert: 25°	Hor: 3.9° Vert: 20°	Hor: 3.5° Vert: 30°	Hor: 2.2° Vert: 22°	Hor: 5.2° Vert: 25°	Hor: 3.9° Vert: 20°	Hor: 3.5° Vert: 30°	Hor: 2.2° Vert: 22°
RF TRANSCEIVER								
1. Peak Output Power	2.2 kW	4 kW	2.2 kW	4 kW	2.2 kW	4 kW	2.2 kW	4 kW
2. Frequency	9410 ± 30 MHz (X-Band)							
3. Pulse length & PRR	0.08 ms/2100 Hz (0.125 to 1 nm) 0.3 ms/1200 Hz (1.5 to 3 nm) 0.8 ms/600 Hz (3 to 48 nm)							
ENVIRONMENT (IEC 60945 test method)								
Temperature	-15°C to +55°C (Display unit) -25°C to +70°C (Antenna unit)							
Waterproofing	IEC 60529 IPX5, USCG CFR-46 (Display unit) IEC 60529 IPX6 (Antenna unit)							
POWER SUPPLY								
	12-24 VDC Max. 44 W	12-24 VDC Max. 46 W	12-24 VDC Max. 47 W	12-24 VDC Max. 50 W	12-24 VDC Max. 52 W	12-24 VDC Max. 54 W	12-24 VDC Max. 55 W	12-24 VDC Max. 58 W
	115/230 VAC with optional rectifier PR-62 /RU-3423							
Optional unit								
Antenna Bracket	OP03-93	OP03-92	Not Available		OP03-93	OP03-92	Not Available	
10-Target Autoplotter	Full control when networked with 10.4" LCD or 10" CRT and ARP-11							
External Buzzer	OP03-136 or Relay/Contact Closure							
NTSC/PAL Interface kit	Not Available							

7-inch LCD (Bracket Mount)

3.5 kg 7.7 lb

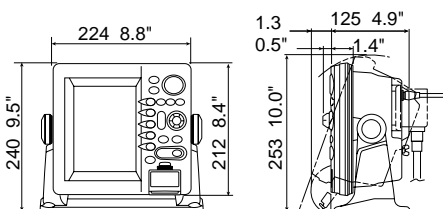

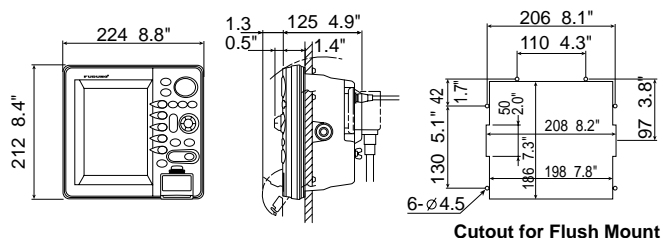

7-inch LCD (Flush Mount)

3.2 kg 7.1 lb



Cutout for Flush Mount

SPECIFICATIONS OF NavNet SERIES

	10" Monochrome CRT Radar / VideoPlotter			10.4" Color LCD Radar / VideoPlotter			
	MODEL 1833	MODEL 1933	MODEL 1943	MODEL 1833C	MODEL 1933C	MODEL 1943C	MODEL 1953C
							
DISPLAY UNIT							
1. Type	10" Green phosphor CRT 481 x 640 pixels			10.4" Color TFT LCD 640 x 480 pixels			
2. NavNet Interface	Ethernet 10-BaseT						
3. Interface (NMEA 0183 format) --: any talker (menu selection)	Input: BWC, BWR, DBT, DPT, GGA, GLL, GSV, HDT, HDM, HDG, MTW, MWV, RMA, RMB, RMC, TTM, VHW, VTG, VYW, VWT, VWR, ZDA Output: AAM, APB, BOD, BWC, BWR, DBT, DPT, GGA, GLL, GTD, HDG, HDT, MHW, MSK, MTW, RMA, RMB, RMC, TLL, TTM, VHW, VTG, WPL, XTE, ZDA						
RADAR CHARACTERISTICS							
1. Display Modes	Head-up, Course-up*, North-up*, True Motion** (* Heading input required ** Heading and speed input required)						
2. Range Scales (nm)	0.125 to 36 nm 15 steps	0.125 to 48 nm 16 steps	0.125 to 64 nm 17 steps	0.125 to 36 nm 15 steps	0.125 to 48 nm 16 steps	0.125 to 64 nm 17 steps	0.125 to 76 nm 18 steps
3. Echo Trail	Interval: 15 s, 30 s, 1 min, 3 min, 6 min, 15 min, 30 min or Continuous						
PLOTTER CHARACTERISTICS							
1. Map Scale	0.125 to 1,024 nm			0.125 to 2,048 nm			
2. Latitude Limits	Between 85°N and 85°S						
3. Plot Interval	1 s to 59 min 59 s or 0.01 to 9.99 nm						
4. Display Modes	Course plot, Nav data, Steering display, Highway						
5. Presentation Modes	TM/RM North-up, Course-up, Auto Course-up						
6. Memory Capacity	Up to 8,000 points for ship's track and marks 1,000 waypoints 200 planned routes (max. 35 waypoints/route)						
7. Alarms	Arrival/anchor watch, XTE, proximity alert, ship speed, depth*, water temperature*, fish* (*Network Sounder required, temperature sensor required for water temperature alarm)						
8. Electronic Charts*	Loaded from a FURUNO MiniChart, Navionics® Nav-Chart, C-MapNT chart cards *Chart must be determined when ordering. Choice of two units: Furuno & Navionics® or C-Map						
ANTENNA RADIATOR							
1. Type	ø 602 mm (24") Radome	1035 mm (3.5 ft) Open	1255 mm (4 ft) Open	ø 602 mm (24") Radome	1035 mm (3.5 ft) Open	1255 mm (4 ft) Open	1795 mm (4/6 ft) Open
2. Rotation Speed * 48 rpm is option.	24 rpm	24/48* rpm	24/48* rpm	24 rpm	24/48 rpm	24/48 rpm	24/48 rpm
3. Wind Load	Relative 100 kt	Relative wind 100 kt (24 rpm) Relative wind 70 kt (48 rpm)		Relative 100 kt	Relative wind 100 kt (24 rpm) Relative wind 70 kt (48 rpm)		Relative 100 kt
4. Beamwidth	Hor: 3.9° Vert: 20°	Hor: 2.2° Vert: 22°	Hor: 1.85° Vert: 22°	Hor: 3.9° Vert: 20°	Hor: 2.2° Vert: 22°	Hor: 1.9° Vert: 22°	Hor: 2.2° Vert: 22°
RF TRANSCEIVER							
1. Peak Output Power	4 kW	4 kW	6 kW	4 kW	4 kW	6 kW	12 kW
2. Frequency	9410 ± 30 MHz (X-Band)						
3. Pulselength & PRR	0.08 µs/2100 Hz (0.125 to 1.5 nm) 0.3 µs/1200 Hz (1.5 to 3 nm) 0.8 µs/600 Hz (3 to 64 nm)					0.08 µs/2100 Hz (0.125 to 1.5 nm) 0.3 µs/1200 Hz (1.5 to 3 nm) 0.8 µs/500 Hz (3 to 64 nm)	
ENVIRONMENT (IEC 60945 test method)							
Temperature	-15°C to +55°C (Display unit) -25°C to +70°C (Antenna unit)						
Waterproofing	IEC 60529 IPX5, USCG CFR-46 (Display unit) IEC 60529 IPX6 (Antenna unit)						
POWER SUPPLY							
	12-24 VDC Max. 55 W	12-24 VDC Max. 73/88 W	12-24 VDC Max. 73/88 W	12-24 VDC Max. 71 W	12-24 VDC Max. 74/82 W	12-24 VDC Max. 84/91 W	12-24 VDC Max. 103/123 W
	115/230 VAC with optional rectifier PR-62/RU-3423						
Optional unit							
Antenna Bracket	OP03-92	Not Available		OP03-92	Not Available		
10-Target Autoplotter	ARP-11* (* Requires appropriate heading sensor)						
External Buzzer	OP03-136 or Relay/Contact Closure						
NTSC/PAL Interface kit	Not Available			OP03-175			
Power Amp Unit	Not Available						PSU-005

10-inch CRT (Bracket Mount)

8.0 kg 17.6 lb

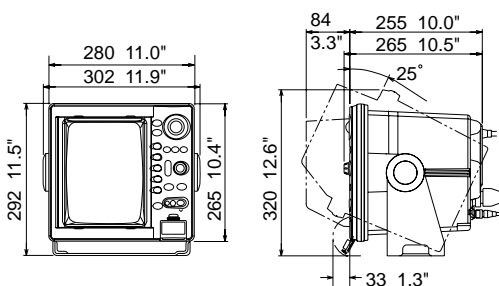

10-inch CRT (Flush Mount)

7.5 kg 16.5 lb

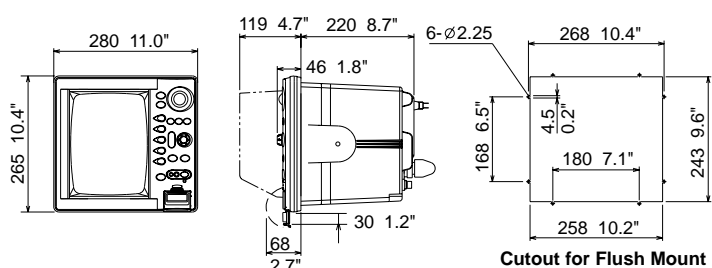

	VideoPlotter		
	GP-1700	GP-1700C	GP-1900C
DISPLAY UNIT			
1. Type	7" Monochrome STN LCD 240 x 320 pixels	7" Color TFT LCD 232 x 320 pixels	10.4" Color TFT LCD 640 x 480 pixels
2. NavNet Interface	Ethernet 10-BaseT		
3. Interface (NMEA 0183 format) --: any talker (menu selection)	Input: BWC, BWR, DBK, DBS, DBT, DPT, GGA, GLL, GSV, HDT*, HDM*, HDG*, MSS, MTW, MWV, RMA, RMB, RMC, TTM, VHW*, VTG, VYW, VWT, VWR, ZDA (* For GP-1900C only) Output: AAM, APB, BOD, BWC, BWR, DBT, DPT, GGA, GLL, GTD, MSK, MTW, RMA, RMB, RMC, TLL, VHW, VTG, WPL, XTE, ZDA		
PLOTTER CHARACTERISTICS			
1. Map Scale	0.125 to 1,024 nm	0.125 to 2,048 nm	
2. Latitude Limits	Between 85°N and 85°S		
3. Plot Interval	1 s to 59 min 59 s or 0.01 to 9.99 nm		
4. Display Modes	Course plot, Nav data, Steering display, Highway		
5. Presentation Modes	TM/RM North-up, Course-up, Auto Course-up		TM/RM North-up, Course-up
6. Memory Capacity	Up to 8,000 points for ship's track and marks 1,000 waypoints 200 planned routes (max. 35 waypoints/route)		
7. Alarms	Arrival/anchor watch, XTE, proximity alert, ship speed, depth*, water temperature*, fish* (*Network Sounder required, temperature sensor required for water temperature alarm)		
8. Electronic Charts*	Loaded from a FURUNO MiniChart, Navionics® Nav-Chart, C-Map ^{NT} chart cards * Chart must be determined upon ordering. Choice of two units: Furuno & Navionics® or C-Map		
ENVIRONMENT (IEC 60945 test method)			
Temperature	-15°C to +55°C		
Waterproofing	IEC 60529 IPX5, USCG CFR-46		
POWER SUPPLY			
	12-24 VDC Max. 18 W	12-24 VDC Max. 28 W	12-24 VDC Max. 40 W
	115/230 VAC with optional rectifier PR-62/RU-3423		
Optional unit			
Autoplotter	Full control when networked with 10.4" LCD or 10" CRT and ARP-11		
External Buzzer	OP03-136 or Relay/Contact Closure		
NTSC/PAL Interface kit	Not Available		OP03-175

	GPS RECEIVER ANTENNA
	GP-310B
RECEIVER CHARACTERISTICS	
Receiver type	Twelve discrete channels, C/A code, all-in-view
Receiver Frequency	L1 (1575.42 MHz)
Time to First Fix	90 seconds typical (Cold start)
Tracking Velocity	999 knots
Geodetic Systems	WGS-84, NAD-27 and others
Accuracy	10 m approx (95% of the time)
ENVIRONMENT (IEC 60945 test method)	
Temperature	-25°C to +70°C
Waterproofing	IEC 60529 IPX6
POWER SUPPLY	
	12 VDC

	NETWORK SOUNDER
	ETR-6/10N
TRANSCIVER CHARACTERISTICS	
Display modes	Single (50 or 200 kHz), Dual (50 and 200 kHz), Bottom-lock, Bottom Zoom, Bottom Discrimination, Marker Zoom, A-Scope
Frequency	Dual frequency 50 and 200 kHz
Output Power	600 W / 1 kW rms
Range Scale	8 basic ranges customized to max 1,200 m (4,000 ft, 650 fa)
Range Phasing	Up to 2,400 m (8,000 ft, 1,300 fa)
ENVIRONMENT (IEC 60945 test method)	
Temperature	-15°C to +55°C
Waterproofing	IEC 60529 IPX2
POWER SUPPLY	
	12-24 VDC Max. 11.0 W
TRANSDUCERS (Specify when ordering)	
50/200 kHz transducers 520-5PSD (Plastic thru-hull), 520-5MSD (Bronze thru-hull), 520-5PWD (Plastic transom), 525ST-MSD (Bronze thru-hull w/speed/temp sensor) 525ST-PWD (Plastic transom w/speed/temp sensor) Single frequency transducers (Optional Matching box MB-1000 required) 50 kHz: 50B-6, 50B-6G, 50B-6B, 50B-62M, 50B-9B, 50B-92M 200 kHz: 200B-5, 200B-5S 50/200-1T, 50/200-12M	

10.4-inch LCD (Bracket Mount) 6.0 kg 13.2 lb

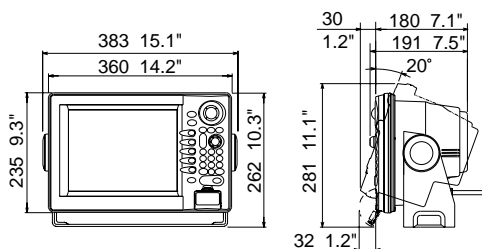

10.4-inch LCD (Flush Mount) 5.2 kg 11.5 lb

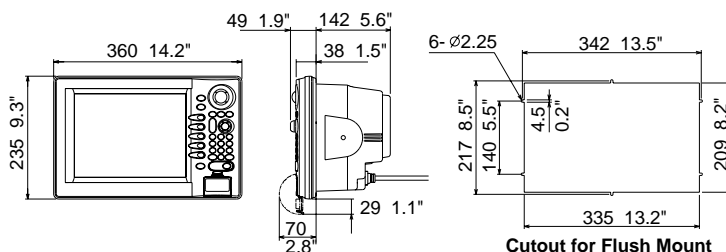

SPECIFICATIONS OF NavNet SERIES

18" Radome Antenna

4.9 kg 10.8 lb

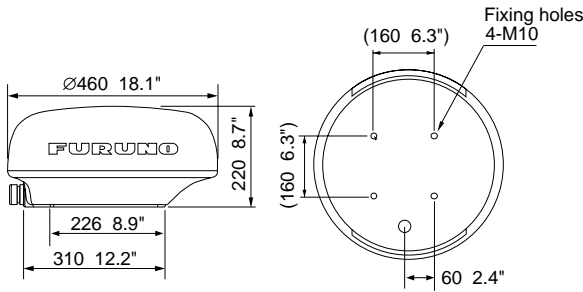

24" Radome Antenna

8 kg 17.6 lb

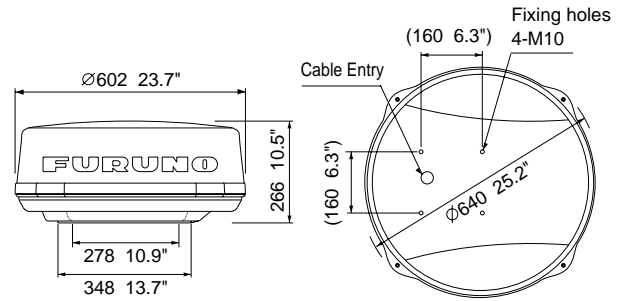

2 ft Open Antenna

11 kg 24.2 lb

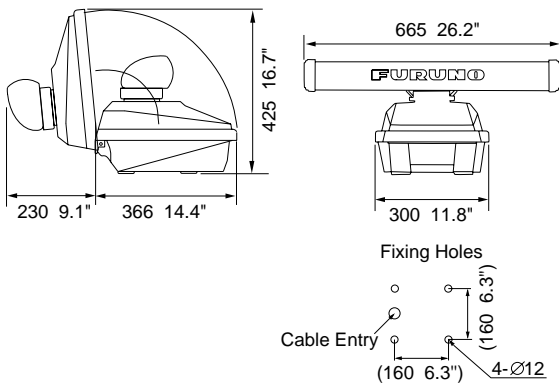

3.5 ft Open Antenna

22 kg 48.5 lb

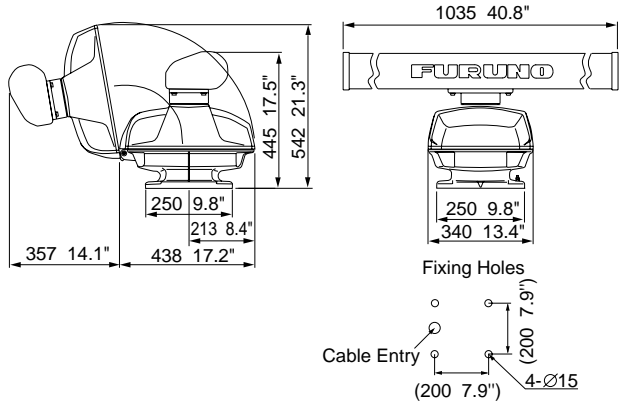

4 ft Open Antenna

23 kg 50.7 lb

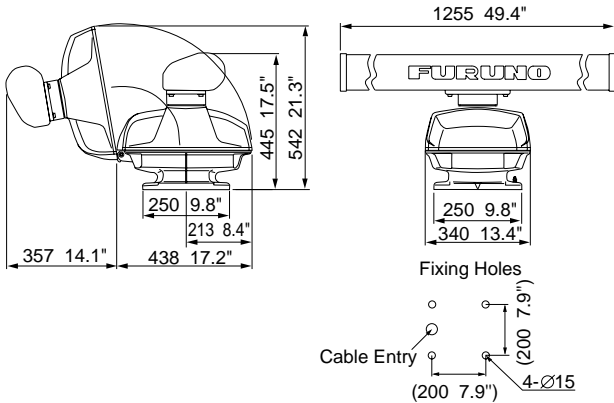

GPS Antenna GP-310B

0.6 kg 1.3 lb

10 m cable attached

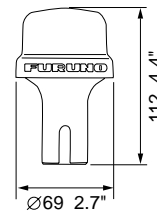

Remote Controller

0.06 kg 0.1 lb

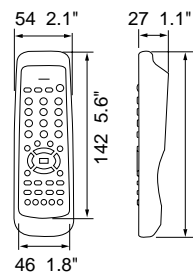

Network Sounder ETR-6/10N

1.5 kg 3.3 lb

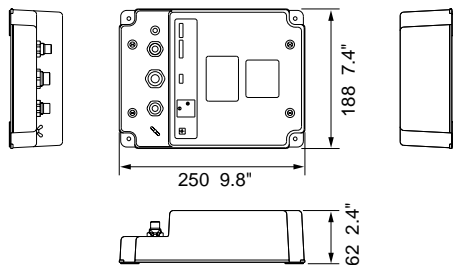

Ethernet is a trade mark of Xerox corporation, registered in U.S. and other countries.
 Navionics® is a trade mark of Navionics®, registered in U.S. and other countries.
 Smart Sensor™ is a trade mark of AIRMAR, registered in U.S. and other countries.

SPECIFICATIONS SUBJECT TO CHANGE WITHOUT NOTICE

FURUNO U.S.A., INC.
 Camas, Washington, U.S.A.
 Phone: +1 360-834-9300 Telefax: +1 360-834-9400

FURUNO (UK) LIMITED
 Denmead, Hampshire, U.K.
 Phone: +44 2392-230303 Telefax: +44 2392-230101

FURUNO FRANCE S.A.
 Bordeaux-Mérignac, France
 Phone: +33 5 56 13 48 00 Telefax: +33 5 56 13 48 01

FURUNO ESPANA S.A.
 Madrid, Spain
 Phone: +34 91-725-90-88 Telefax: +34 91-725-98-97

FURUNO DANMARK AS
 Hvidovre, Denmark
 Phone: +45 36 77 45 00 Telefax: +45 36 77 45 01

FURUNO NORGE A/S
 Ålesund, Norway
 Phone: +47 70 102950 Telefax: +47 70 127021

FURUNO SVERIGE AB
 Västra Frölunda, Sweden
 Phone: +46 31-7098940 Telefax: +46 31-497093

FURUNO SUOMI OY
 Helsinki, Finland
 Phone: +358 9 341 7570 Telefax: +358 9 341 75716

0204XXVKS Printed in Japan

