

Hydraulic Linear Drive Installation Guide

Drives covered:

M81200	Type 2 Hydraulic Linear Drive 12 V
M81201	Type 2 Hydraulic Linear Drive 24 V
M81202	Type 3 Hydraulic Linear Drive 12 V
M81203	Type 3 Hydraulic Linear Drive 24 V

Document number: 81177-3
March 2001

Raymarine
ON BOARD



Important information

Safety notices

WARNING: Product installation

This equipment must be installed and operated in accordance with the instructions contained in this handbook. Failure to do so could result in poor product performance, personal injury and/or damage to your boat.

Because correct performance of the boat's steering is critical for safety, we **STRONGLY RECOMMEND** that an Authorized Raymarine Service Representative fits this product.

WARNING: Navigation aid

Although we have designed this product to be accurate and reliable, many factors can affect its performance. As a result, it should only be used as an aid to navigation and should never replace commonsense and navigational judgement. Always maintain a permanent watch so you can respond to situations as they develop.

EMC conformance

All Raymarine equipment and accessories are designed to the best industry standards for use in the recreational marine environment. The design and manufacture of Raymarine equipment and accessories conform to the appropriate Electromagnetic Compatibility (EMC) standards, but correct installation is required to ensure that performance is not compromised.

Handbook information

To the best of our knowledge, the information in this handbook was correct when it went to press. However, Raymarine cannot accept liability for any inaccuracies or omissions it may contain. In addition, our policy of continuous product improvement may change specifications without notice. As a result, Raymarine cannot accept liability for any differences between the product and the handbook.

Introduction

Welcome to the installation guide for the Raymarine hydraulic linear drive system. This product is intended to operate the boat's steering mechanism as part of a Raymarine autopilot system.

The hydraulic linear drive system is designed for boats with existing mechanical steering systems, not hydraulic steering systems. It provides a totally isolated autopilot steering system consisting of:

- Hydraulic ram: a self-contained autopilot steering cylinder with a load limiting system and a built in clutch (to allow friction-free steering when the autopilot is not in use).
- Reversing hydraulic pump: powers the hydraulic ram.
- Hydraulic fluid reservoir: supplies hydraulic fluid to the system.

CAUTION:

The ram drives the rudder directly from the tiller arm or rudder quadrant. Before installing this drive unit, check that the boat's steering system can be backdriven from the rudder.

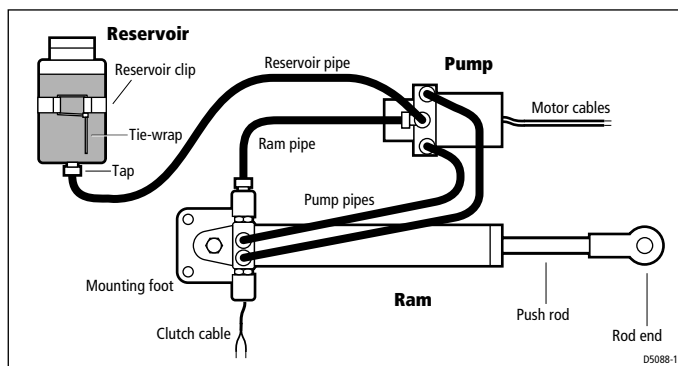

Figure 1: Main components of the hydraulic linear drive system

Contents

1	Product specifications	page 4
2	Installation instructions	page 5
3	Maintenance information	page 15

Specifications

Ram specifications

Table 1: Ram specifications

Performance (at nominal voltage)	Type 2 (T2) M81200 (12 V) M81201 (24 V)	Type 3 (T2) M81202 (12 V) M81203 (24 V)
Maximum boat displacement	22,000 kg (48,500 lb)	35,000 kg (77,000 lb)
Peak thrust	585 kg (1,290 lb)	1,200 kg (2,700 lb)
Maximum stroke	254 mm (10 in)	300 mm (12 in)
Hardover to hardover time (+/- 35°, no load)	10 sec	12 sec
Maximum rudder torque	1,270 Nm (11,300 lb.in)	3,200 Nm (28,800 lb.in)
Other information	(applies to Types 2 and 3)	
	protected for use in engine compartments	
	CE approvals - conforms to: 89/336/EC (EMC), EN60945:1997 94/25/EC (RCD), EN28846:1993	

Ram dimensions

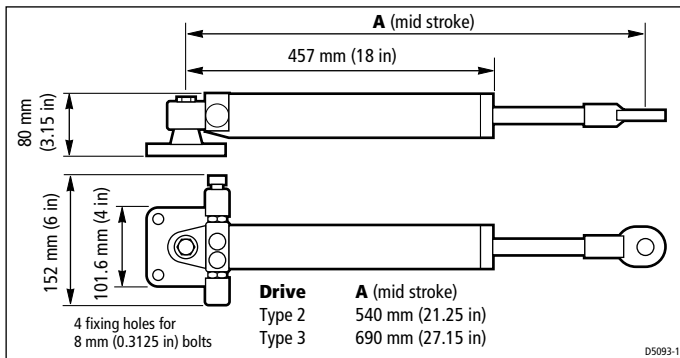

Figure 2: Ram dimensions

Installation instructions

Parts required

To install this drive you will need:

- Parts supplied:
 - pre-filled and pre-bled system consisting of: hydraulic ram; hydraulic pump; hydraulic pipes; fluid reservoir (supplied fitted with transit cap; standard cap also supplied)
 - hydraulic fluid (to fill reservoir)
 - tiller pin assembly (see *Figure 7*) consisting of: tiller pin, R-clip, top washer, lock washer, nut (UNC nylock)
- Additional parts:
 - suitable securing bolts and lock washers/lock nuts for the hydraulic ram and pump (see *page 9*)
 - suitable cable and electrical connectors for the drive motor and clutch (see *page 12*)

Note: *Make sure you have obtained these additional parts before you start installation.*

Installation steps

WARNING: Electrical safety

Make sure you have switched off the power supply before you start installing this product.

Follow these steps to install your hydraulic linear drive system:

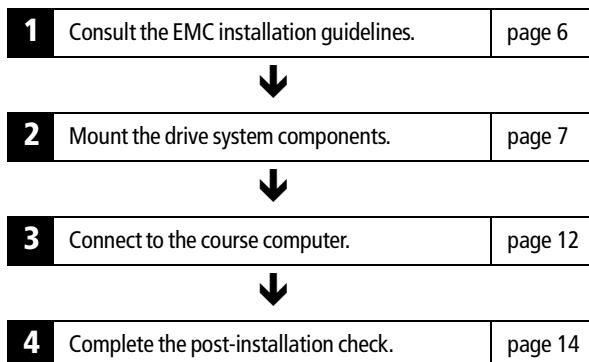

1. EMC installation guidelines

All Raymarine equipment and accessories are designed to the best industry standards for use in the recreational marine environment.

Their design and manufacture conforms to the appropriate Electromagnetic Compatibility (EMC) standards, but correct installation is required to ensure that performance is not compromised. Although every effort has been taken to ensure that they will perform under all conditions, it is important to understand what factors could affect the operation of the product.

The guidelines given here describe the conditions for optimum EMC performance, but it is recognized that it may not be possible to meet all of these conditions in all situations. To ensure the best possible conditions for EMC performance within the constraints imposed by any location, always ensure the maximum separation possible between different items of electrical equipment.

For **optimum** EMC performance, it is recommended that **wherever possible**:

- Raymarine equipment and cables connected to it are:
 - At least 3 ft (1 m) from any equipment transmitting or cables carrying radio signals e.g. VHF radios, cables and antennas. In the case of SSB radios, the distance should be increased to 7 ft (2 m).
 - More than 7 ft (2 m) from the path of a radar beam. A radar beam can normally be assumed to spread 20 degrees above and below the radiating element.
- The equipment is supplied from a separate battery from that used for engine start. Voltage drops below 10 V, and starter motor transients, can cause the equipment to reset. This will not damage the equipment, but may cause the loss of some information and may change the operating mode.
- Raymarine specified cables are used. Cutting and rejoining these cables can compromise EMC performance and must be avoided unless doing so is detailed in the installation manual.
- If a suppression ferrite is attached to a cable, this ferrite should not be removed. If the ferrite needs to be removed during installation it must be reassembled in the same position.

Suppression ferrites

The following illustration shows typical cable suppression ferrites used with Raymarine equipment. Always use the ferrites supplied by Raymarine.

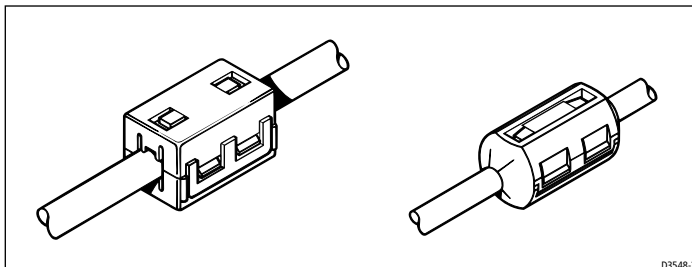

Figure 3: Typical Suppression Ferrites

Connections to other equipment

If your Raymarine equipment is to be connected to other equipment using a cable not supplied by Raymarine, a suppression ferrite **MUST** always be attached to the cable near to the Raymarine unit.

2. Mounting the drive components

Mounting the drive components involves four main steps:

- ensuring correct hydraulic ram alignment
- securing the hydraulic ram to the boat
- connecting the hydraulic ram to the steering system
- installing the other parts of the drive system

Ram alignment

When mounting the hydraulic ram, check that it is aligned correctly:

- The ram must be at right angles to the mounting surface (see *Figure 4*).
- The ram must be at right angles to the tiller arm when the rudder is amidships (see *Figure 4*).
- The push rod must be accurately aligned with the tiller arm plane of rotation. The ball end fitting only allows up to 5 degrees misalignment between the push rod and tiller arm plane of rotation (see *Figure 5*).

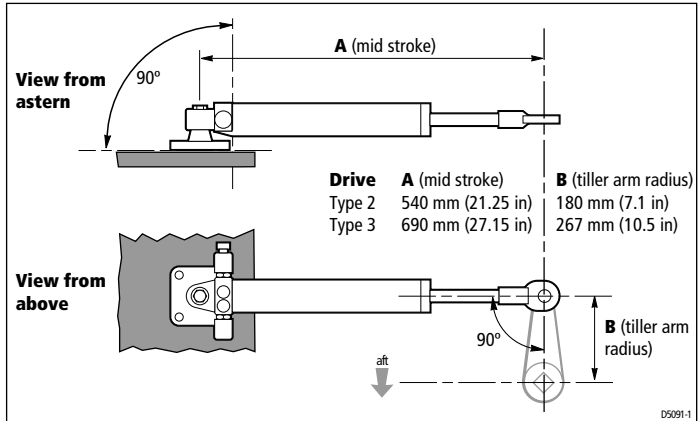

Figure 4: Hydraulic ram alignment

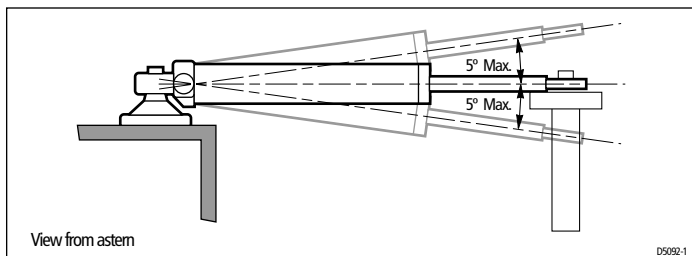

Figure 5: Alignment between push rod and tiller arm plane of rotation

CAUTION:

Accurate angular alignment is extremely important. You must not exceed this +/- 5 degree limit under any circumstances.

Securing the hydraulic ram

Mounting location

Before you secure the hydraulic ram to your boat, you must first check the suitability of the mounting location.

CAUTION:

Consult the boat manufacturer if you have any doubt about the strength or suitability of the mounting location.

- **Structural strength:**
 - This drive produces a considerable amount of force, so you must mount it on a solid structure (i.e. a substantial frame member) in the boat. In some cases it may be necessary to build a specially strengthened frame to mount the drive unit.
 - To prevent excess noise and vibration, do not attach this drive to any structures that support cabins.
- **Drive orientation:**
 - You must mount the hydraulic ram horizontally with its mounting foot on a horizontal surface (see *Figure 6*). The swivel joint does not have sufficient movement to position the mounting foot vertically.
- **General position:**
 - Refer to the EMC installation guidelines (*page 6*)
 - Make sure the drive will be accessible for future servicing.
- **Environment:**
 - This drive is not waterproof, so you should mount it in a dry location, clear of any bilge water.

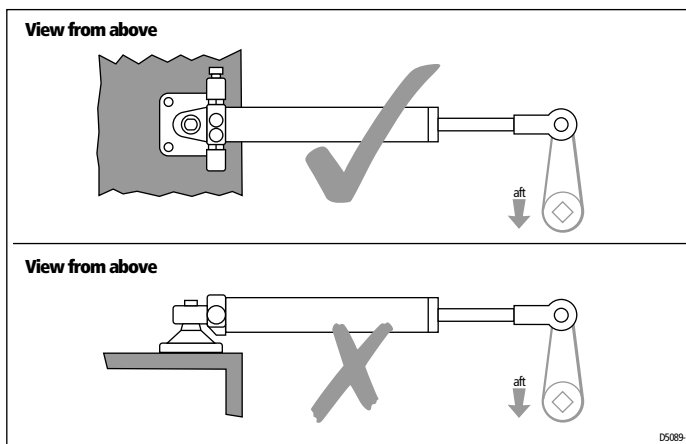

Figure 6: Drive orientation

Securing bolts

Attach the mounting foot with four stainless steel M8 ($\frac{5}{16}$ inch) bolts and lock nuts/lock washers.

Note: Always mount the hydraulic ram as securely as possible to make sure it performs reliably and remains correctly aligned.

Connecting to the steering system

CAUTION:

Consult the steering gear manufacturer if you have any doubt about the strength of the existing tiller arm or rudder quadrant.

This drive produces a considerable amount of force, so you must ensure that your tiller arm or rudder quadrant can cope with the peak thrust specified in the *Table 1, Ram specifications*

Use one of these methods to attach the push rod to the rudder stock:

1. **Independent tiller arm:** we recommend that you attach the push rod to the rudder stock via an independent tiller arm (Edson and Whitlock offer a standard fitting).
2. **Steering linkage tiller arm or rudder quadrant:** in certain cases, you may be able to attach the push rod to the same tiller arm or rudder quadrant used by the main steering linkage. Consult the steering manufacturer before you modify the rudder quadrant.

Attaching the rod end

Use the supplied tiller pin assembly to attach the rod end to the tiller arm, at the tiller arm radius shown in *Figure 4*.

1. Attach the tiller pin to the tiller arm:
 - insert the tiller pin through the tiller arm hole, so the flange remains above the arm (see *Figure 7*)
 - make sure that the tiller pin is a tight fit in the tiller arm
 - use the supplied lock washer and fully tighten the lock nut

Note: *If necessary, you will need to drill a hole in the tiller arm at the radius shown in Figure 4.*

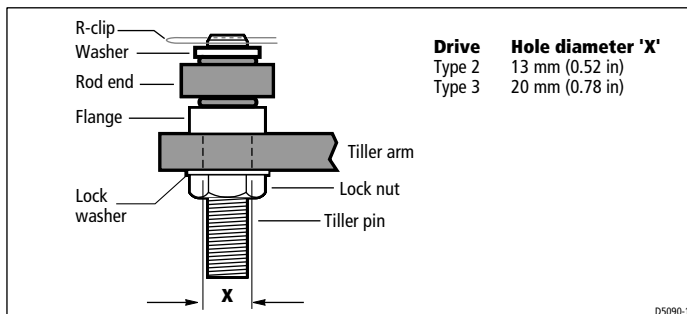

Figure 7: Attaching the push rod to the tiller arm

2. Attach the rod end to the tiller pin:
 - place the rod end onto the tiller pin
 - secure with the supplied washer and R-clip (see *Figure 7*)

Steering check

When you have mounted the ram, turn the boat's steering wheel from hardover to hardover and check that:

- Angular movement of the ball end fitting is less than 5 degrees (see *Figure 5*). If you exceed this 5 degree limit, the drive will catch on the tiller arm/rudder quadrant and the ball joint will bind.
- No part of the drive unit fouls the boat's structure when the push rod moves in and out.
- The total rudder movement is limited to +/- 35 degrees by the steering system end stops rather than the linear drive's end limits (see *Figure 8*).

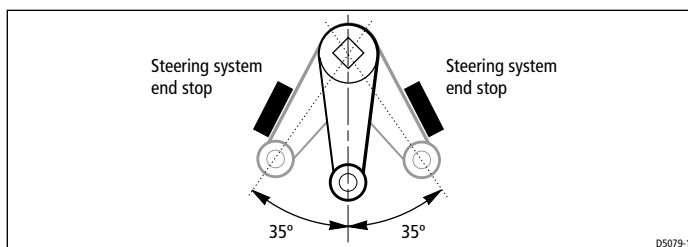

Figure 8: Total rudder movement

CAUTION:

Make sure rudder movement is limited by the steering system end stops before the push rod reaches its end stop. Failure to do this could damage the drive and will invalidate the warranty.

Installing the other parts of the system

Note: *To make installation easier, we supply the hydraulic linear drive system pre-plumbed, pre-filled with hydraulic fluid and pre-bled, with just the reservoir empty. As a result you should not need to bleed the system during installation. If you do need to disconnect the pipes for any reason, contact Raymarine Technical Services Call Center for advice on bleeding the system.*

Hydraulic pump

Mount the hydraulic pump:

- on a substantial member to avoid vibration that could damage the hydraulic pipes
- on a horizontal surface, clear of water spray and possible immersion.
- **level or above the hydraulic ram** to prevent air from collecting in the ram

Note: *Secure the pump using suitable bolts, lock nuts & lock washers.*

Reservoir

Mount the reservoir vertically and at least **150 mm (6 in)** above the hydraulic pump (to ensure a good supply of fluid to the system):

1. Attach the clip, then use the tie-wrap to secure the reservoir to the clip.
2. Remove the **temporary** (non-breathable) transit cap fitted to the reservoir.
3. Fill the reservoir with the supplied hydraulic fluid, so the level is between the minimum and maximum lines.

CAUTION:

Absolute cleanliness is essential when working with hydraulic systems. Even the smallest particle of dirt could prevent the steering system check valves from working properly.

4. Fit the supplied **standard** (breathable) cap to the reservoir.
5. Open the reservoir tap.

3. Connecting to the course computer

WARNING: Electrical safety

Make sure the power supply is switched off before you make any electrical connections.

The hydraulic linear drive system has electrical connections for:

- the motor in the pump: two cables: red (+) and black (-)
- the clutch in the hydraulic ram: a two-core cable with brown (+) and blue (-) cores

Table 2: Recommended cable sizes

Cable length (pump to course computer)	Cable gauge (AWG)	Copper area (mm ²)
Type 2 drive 12 V		
up to 5 m (16 ft)	10	6
up to 7 m (23 ft)	8	10
up to 16 m (52 ft)	6	16
Type 2 drive 24 V		
up to 3 m (10 ft)	12	4
up to 5 m (16 ft)	10	6
up to 10 m (32 ft)	8	10
up to 16 m (52 ft)	6	16
Type 3 drive 12 V		
up to 5 m (16 ft)	8	10
up to 7 m (23 ft)	6	16
up to 16 m (52 ft)	4	25
Type 3 drive 24 V		
up to 5 m (16 ft)	10	6
up to 7 m (23 ft)	8	10
up to 16 m (52 ft)	6	16

Connect the pump and ram to the course computer:

1. Measure the distance of cable run from the pump and ram to the course computer:
 - use *Table 2* to identify the appropriate motor cable sizes
 - use at least 1.5 mm² (16 AWG) copper cable for the clutch
2. Join these cables to the ones on the pump and ram using appropriate electrical connectors or junction boxes at the correct power rating.

Note: *To meet current EMC legislation, you must NOT untwist the pump cables, and you must NOT remove the suppression ferrite.*

3. Route the cables back to the course computer, taking into account the EMC installation guidelines (*page 6*).
4. Connect:
 - the cables from the pump to the **MOTOR** terminals on the course computer (see *Figure 9*): at this stage you can connect either motor cable to either terminal. You will check these connections after installing the rest of the autopilot system.
 - the cables from the hydraulic ram to the **CLUTCH** terminals on the course computer (see *Figure 9*): brown (+) and blue (-)

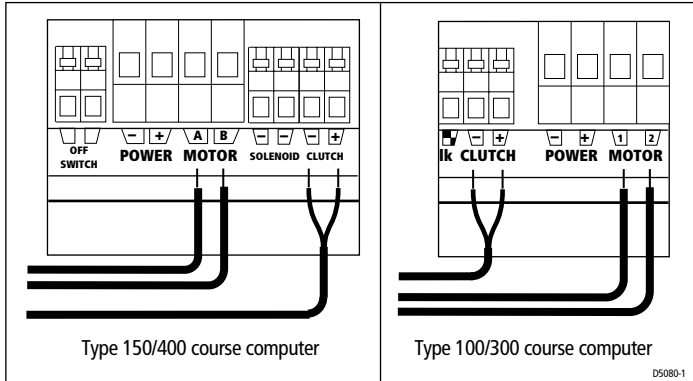

Figure 9: Cable connections at course computer

4. Post-installation check

WARNING:

Keep clear of moving steering systems at all times. Protect moving parts from access during normal use.

Check the following points after installing the drive:

1. Is the mounting foot secured to a substantial structure on the boat?
2. Is the hydraulic ram correctly aligned, i.e:
 - Is the mounting foot correctly oriented?
 - Is the drive mounted at right angles to the tiller arm, in a mid-stroke position, when the rudder is amidships?
 - Is the push rod accurately aligned with the tiller arm plane of rotation (deviation less than 5 degrees)?
3. Is the hydraulic ram rod end:
 - securely attached to the tiller arm or quadrant?
 - attached at the recommended tiller arm radius for the boat?
4. Are the motor and clutch cables correctly routed and securely connected to the course computer?
5. Are all hydraulic pipes securely connected, with no leaks?
6. Have you filled the reservoir, fitted the standard cap and opened the reservoir tap?
7. Have you completed a hand-steering check (see page 11)?

Note: When you have installed the entire autopilot system, you will need to complete an autopilot steering check. Refer to the control unit handbook for more details.

Maintenance

On a regular basis:

- check all connection and mountings are secure
- check hydraulic ram alignment
- check pipes and cables for any signs of wear or damage
- check hydraulic pipes and joints for leaks

EMC servicing and safety guidelines

- Raymarine equipment should be serviced only by authorized Raymarine service technicians. They will ensure that service procedures and replacement parts used will not affect performance. There are no user serviceable parts in any Raymarine product.
- Some products generate high voltages, so never handle the cables or connectors when power is being supplied to the equipment.
- When powered up, all electrical equipment produces electromagnetic fields. These can cause adjacent pieces of electrical equipment to interact with one another, with a consequent adverse effect on operation. In order to minimize these effects and enable you to get the best possible performance from your Raymarine equipment, guidelines are given in the installation instructions, to enable you to ensure minimum interaction between different items of equipment, i.e. ensure optimum Electromagnetic Compatibility (EMC).
- Always report any EMC-related problem to your nearest Raymarine dealer. We use such information to improve our quality standards.
- In some installations, it may not be possible to prevent the equipment from being affected by external influences. In general this will not damage the equipment but it can lead to spurious resetting action, or momentarily may result in faulty operation.

Product support

Raymarine products are supported by a worldwide network of distributors and Authorized Service Representatives. If you encounter any difficulties with this product, please contact either your national distributor, or your service representative, or the **Raymarine Technical Services Call Center**. Refer to the back cover or the Worldwide Distributor List for contact details.

Raymarine Ltd

Anchorage Park
Portsmouth, Hampshire
England PO3 5TD
Telephone +44 (0)23 9269 3611
Fax +44 (0)23 9269 4642
www.raymarine.com

Raymarine Inc

22 Cotton Road, Suite 280
Nashua
NH 03063-4219, USA
Telephone +1 603 881 5200
Fax +1 603 864 4756
www.raymarine.com

**Raymarine Technical Services Call Center**

UK: +44 (0)23 9271 4713 or
+44 (0)23 9269 3611 ext. 1083

USA: +1 603 881 5200 or
1-800-539-5539 ext. 2333