

Linear Drive Installation Guide

Drives covered:

M81130	Type 1 Linear Drive 12 V
M81131	Type 2 (short) Linear Drive 12 V
M81132	Type 2 (long) Linear Drive 12 V
M81133	Type 2 (short) Linear Drive 24 V
M81134	Type 2 (long) Linear Drive 24 V

Document number: 81175-3

March 2001

Raymarine
ON BOARD



Important information

Safety notices

WARNING: Product installation

This equipment must be installed and operated in accordance with the instructions contained in this handbook. Failure to do so could result in poor product performance, personal injury and/or damage to your boat.

Because correct performance of the boat's steering is critical for safety, we **STRONGLY RECOMMEND** that an Authorized Raymarine Service Representative fits this product.

WARNING: Navigation aid

Although we have designed this product to be accurate and reliable, many factors can affect its performance. As a result, it should only be used as an aid to navigation and should never replace commonsense and navigational judgement. Always maintain a permanent watch so you can respond to situations as they develop.

EMC conformance

All Raymarine equipment and accessories are designed to the best industry standards for use in the recreational marine environment. The design and manufacture of Raymarine equipment and accessories conform to the appropriate Electromagnetic Compatibility (EMC) standards, but correct installation is required to ensure that performance is not compromised.

Handbook information

To the best of our knowledge, the information in this handbook was correct when it went to press. However, Raymarine cannot accept liability for any inaccuracies or omissions it may contain. In addition, our policy of continuous product improvement may change specifications without notice. As a result, Raymarine cannot accept liability for any differences between the product and the handbook.

Introduction

Product description

Welcome to the installation guide for the Raymarine linear drive. This product is intended to operate the boat's steering mechanism as part of a Raymarine autopilot system. It is designed for boats with existing mechanical steering systems

CAUTION:

This drive moves the rudder directly from the tiller arm or rudder quadrant. Before installing the drive, check that the boat's steering system can be backdriven from the rudder.

The outstanding design of the Raymarine linear drive unit provides:

- powerful thrust, fast hardover times and quiet operation
- low backdrive force, to minimize the drive's effect on the boat's steering when the autopilot is in standby
- a powerful electric motor controlled by an electromagnetic fail-safe clutch, using a high tensile belt drive and epicyclic gearbox
- high performance for minimum current consumption

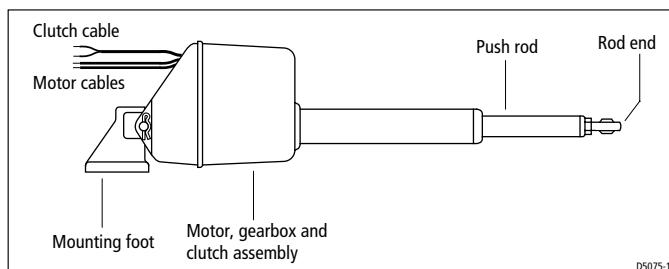

Figure 1: Main parts of the linear drive

Contents

This guide contains:

1	Product specifications	page 4
2	Installation instructions	page 5
3	Maintenance information	page 14

Specifications

Drive specifications

Table 1: Drive specifications

Performance* (at nominal voltage)	Type 1 (T1) M81130 (12 V)	Type 2 short (T2S) M81131 (12 V) M81133 (24 V)	Type 2 long (T2L) M81132 (12 V) M81134 (24 V)
Maximum boat displacement	10,000 kg (22,000 lb)	15,000 kg (33,000 lb)	20,000 kg (44,000 lb)
Peak thrust	295 kg (650 lb)	480 kg (1,050 lb)	480 kg (1,050 lb)
Maximum stroke	300 mm (12 in)	300 mm (12 in)	400 mm (16 in)
Hardover to hardover time (+/- 35°, no load)	11 sec	11 sec	14 sec
Maximum rudder torque	735 Nm (6,500 lb.in)	1,190 Nm (10,500 lb.in)	1,660 Nm (14,700 lb.in)
Power consumption (typical average)	18-36 W	48-72 W (12 V) 66-96W (24 V)	
Other information	(applies to Types 1 and 2 short/long)		
	protected for use in engine compartments		
	CE approvals - conforms to: 89/336/EC (EMC), EN60945:1997 94/25/EC (RCD), EN28846:1993		

Drive dimensions

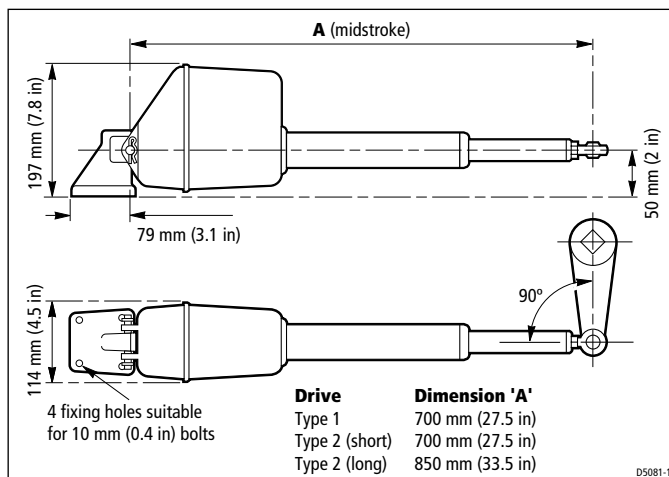

Figure 2: Linear drive dimensions

Installation instructions

Parts required

To install this drive you will need:

- Parts supplied:
 - linear drive
 - mounting foot assembly, consisting of: foot, pivot pin, washer (x2), R-clip (x2)
 - tiller pin assembly (see *Figure 6*) consisting of: tiller pin, R-clip, top washer, lock washer, nut ($\frac{1}{2}$ inch UNC nylock)
- Additional parts:
 - suitable securing bolts and lock nuts/lock washers (see *page 10*)
 - suitable cable and electrical connectors for the drive motor and clutch (see *page 12*)

Note: Make sure you have obtained these additional parts before you start installation.

Installation steps

WARNING: Electrical safety

Make sure you have switched off the power supply before you start installing this product.

Follow these steps to install your linear drive unit:

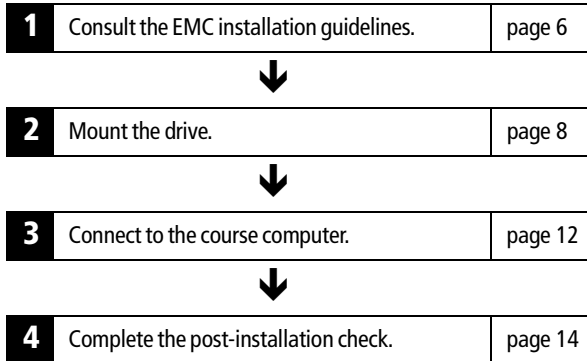

1. EMC installation guidelines

All Raymarine equipment and accessories are designed to the best industry standards for use in the recreational marine environment.

Their design and manufacture conforms to the appropriate Electromagnetic Compatibility (EMC) standards, but correct installation is required to ensure that performance is not compromised. Although every effort has been taken to ensure that they will perform under all conditions, it is important to understand what factors could affect the operation of the product.

The guidelines given here describe the conditions for optimum EMC performance, but it is recognized that it may not be possible to meet all of these conditions in all situations. To ensure the best possible conditions for EMC performance within the constraints imposed by any location, always ensure the maximum separation possible between different items of electrical equipment.

For **optimum** EMC performance, it is recommended that **wherever possible**:

- Raymarine equipment and cables connected to it are:

- At least 3 ft (1 m) from any equipment transmitting or cables carrying radio signals e.g. VHF radios, cables and antennas. In the case of SSB radios, the distance should be increased to 7 ft (2 m).
- More than 7 ft (2 m) from the path of a radar beam. A radar beam can normally be assumed to spread 20 degrees above and below the radiating element.
- The equipment is supplied from a separate battery from that used for engine start. Voltage drops below 10 V, and starter motor transients, can cause the equipment to reset. This will not damage the equipment, but may cause the loss of some information and may change the operating mode.
- Raymarine specified cables are used. Cutting and rejoining these cables can compromise EMC performance and must be avoided unless doing so is detailed in the installation manual.
- If a suppression ferrite is attached to a cable, this ferrite should not be removed. If the ferrite needs to be removed during installation it must be reassembled in the same position.

Suppression ferrites

The following illustration shows typical cable suppression ferrites used with Raymarine equipment. Always use the ferrites supplied by Raymarine. This product has ferrites mounted internally.

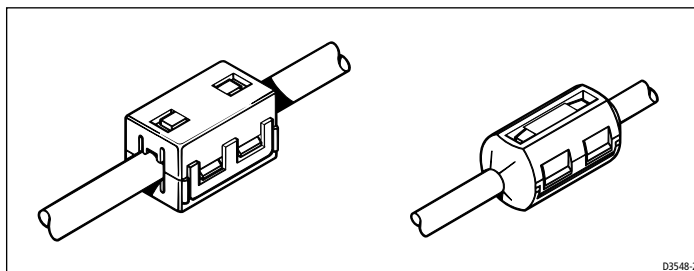

Figure 3: Typical suppression ferrites

Connections to other equipment

If your Raymarine equipment is to be connected to other equipment using a cable not supplied by Raymarine, a suppression ferrite **MUST** always be attached to the cable near to the Raymarine unit.

2. Mounting the drive

Mounting the drive unit involves four main steps:

- ensuring correct drive alignment
- securing the drive to the boat
- connecting the drive to the steering system
- completing a steering check

Drive alignment

When mounting the linear drive unit, check that it is aligned correctly:

- The main drive assembly must be at right angles to the mounting surface (see *Figure 4*).
- The drive unit must be at right angles to the tiller arm when the rudder is amidships (see *Figure 4*).

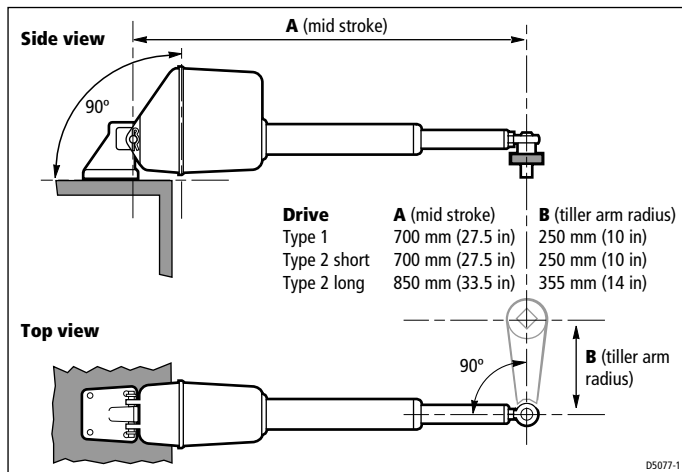

Figure 4: Drive unit alignment

- The push rod must be accurately aligned with the tiller arm plane of rotation. The ball end fitting only allows up to 5 degrees misalignment between the push rod and tiller arm plane of rotation (see *Figure 5*).

CAUTION:

Accurate angular alignment is extremely important. You must not exceed this +/- 5 degree limit under any circumstances.

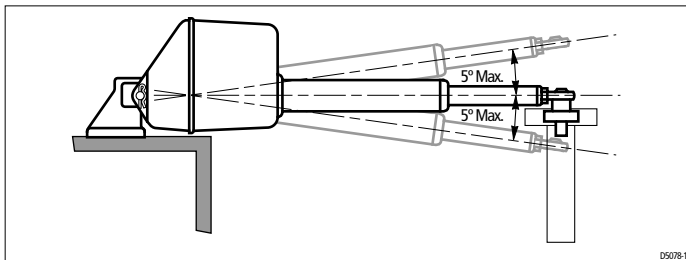

Figure 5: Alignment between push rod and tiller arm plane of rotation

Securing the drive

Mounting location

Before you secure the drive to your boat, you must first check the suitability of the mounting location.

CAUTION:

Consult the boat manufacturer if you have any doubt about the strength or suitability of the mounting location.

- **Structural strength:**
 - This drive produces a considerable amount of force, so you must mount it on a solid structure (i.e. a substantial frame member) in the boat. In some cases you may need to build a special frame to mount the drive unit.
 - To prevent excess noise and vibration, do not attach this drive to any structures that support cabins.
- **Drive orientation:**
 - You can attach the drive unit mounting foot to any suitable horizontal or vertical surface. If required, you can also mount the drive unit upside down.
- **General position:**
 - Refer to the EMC installation guidelines (*page 6*)
 - Make sure the drive will be accessible for future servicing.
- **Environment:**
 - This drive is not waterproof, so you should mount it in a dry location, clear of any bilge water.

Securing bolts

Attach the mounting foot with four stainless steel M10 ($\frac{3}{8}$ inch) bolts and lock nuts/lock washers.

Note: *Always mount the drive as securely as possible to make sure it performs reliably and remains correctly aligned.*

Connecting to the steering system

CAUTION:

Consult the steering gear manufacturer if you have any doubt about the strength of the existing tiller arm or rudder quadrant.

This drive produces a considerable amount of force, so you must ensure that your tiller arm or rudder quadrant can cope with the peak thrust specified in the *Table 1, Drive specifications*.

Use one of these methods to attach the push rod to the rudder stock:

1. **Independent tiller arm:** we recommend that you attach the linear drive unit to the rudder stock via an independent tiller arm (the Edson and Whitlock companies offer standard fittings for their steering systems).
2. **Steering linkage tiller arm or rudder quadrant:** in certain cases, you may be able to attach the push rod to the same tiller arm or rudder quadrant used by the main steering linkage. Consult the steering manufacturer before you modify the rudder quadrant.

Attaching the rod end

Use the supplied tiller pin assembly to attach the rod end to the tiller arm, at the tiller arm radius shown in *Figure 4*.

1. Attach the tiller pin to the tiller arm:
 - insert the tiller pin through the tiller arm hole, so the flange remains above the arm (see *Figure 6*)
 - make sure that the tiller pin is a tight fit in the tiller arm
 - use the supplied lock washer and fully tighten the lock nut

Note: *If necessary, you will need to drill a 13 mm (0.52 in) hole in the tiller arm at the radius shown in *Figure 4*.*

2. Attach the rod end to the tiller pin:
 - place the rod end onto the tiller pin
 - secure with the supplied washer and R-clip (see *Figure 6*)

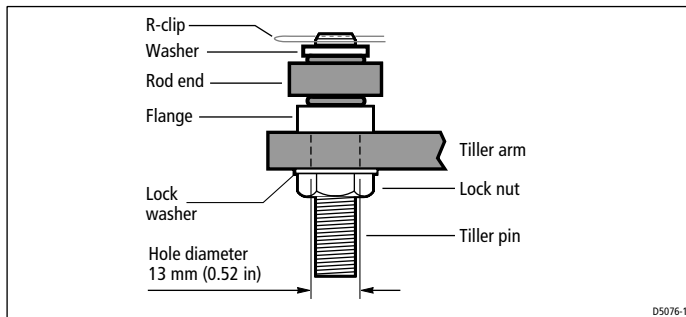

Figure 6: Attaching the push rod to the tiller arm

Steering check

When you have mounted the drive unit, turn the boat’s steering wheel from hardover to hardover and check that:

- Angular movement of the ball end fitting is less than 5 degrees (see *Figure 5*). If you exceed this 5 degree limit, the drive will catch on the tiller arm/rudder quadrant and the ball joint will bind.
- No part of the drive unit fouls the boat’s structure when the push rod moves in and out.
- The total rudder movement is limited to +/- 35 degrees by the steering system end stops rather than the linear drive’s end limits (see *Figure 7*).

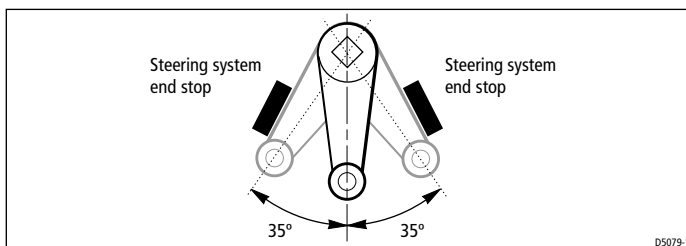

Figure 7: Total rudder movement

CAUTION:

Make sure rudder movement is limited by the steering system end stops before the push rod reaches its end stop. Failure to do this could damage the drive and will invalidate the warranty.

WARNING:

Keep clear of moving steering systems at all times. Protect moving parts from access during normal use.

3. Connecting to the course computer

WARNING: Electrical safety

Make sure the power supply is switched off before you make any electrical connections.

The linear drive unit has electrical connections for:

- the drive motor: two single-core cables: red and black
- the clutch: a two-core cable with red (+) and blue (-) cores

Follow these steps to connect the linear drive to the course computer:

1. Measure the distance of cable run from the drive unit to the course computer:
 - use *Table 2* to identify the appropriate motor cable size
 - use at least 1.5 mm² (16 AWG) copper cable for the clutch
2. Join these cables to the drive cables using appropriate electrical connectors or junction boxes at the correct power rating.
3. Route the cables back to the course computer, taking into account the EMC installation guidelines (see *page 6*).
4. Connect the cables to the course computer (see *Figure 8*):
 - **CLUTCH** cable: red core to +ve, blue core to -ve
 - **MOTOR** cables: at this stage you can connect either motor cable to either terminal. You will check these connections after installing the rest of the autopilot system.

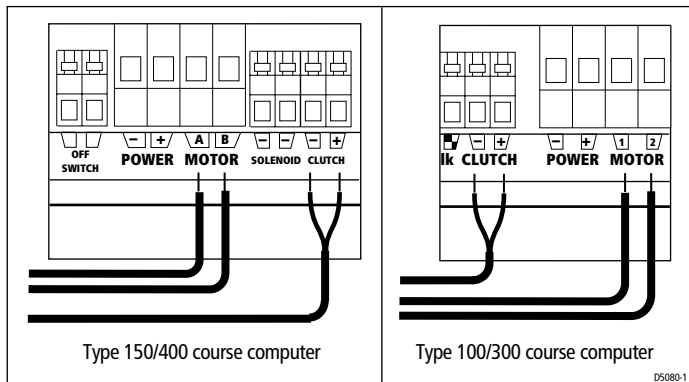

Figure 8: Cable connections at course computer

Table 2: Recommended cable sizes

Cable length (drive unit to course computer)	Cable gauge (AWG)	Copper area (mm ²)
Type 1 drive		
up to 3m (10ft)	14	2.5
up to 5m (16ft)	12	4
up to 7m (23ft)	10	6
up to 10m (32ft)	8	10
up to 16m (52ft)	6	16
Type 2 drive 12 V (short/long)		
up to 5m (16ft)	10	6
up to 7m (23ft)	8	10
up to 16m (52ft)	6	16
Type 2 drive 24 V (short/long)		
up to 3m (10ft)	12	4
up to 5m (16ft)	10	6
up to 10m (32ft)	8	10
up to 16m (52ft)	6	16

4. Post installation checklist

Check the following points after installing the drive:

1. Is the mounting foot secured to a substantial structure on the boat?
2. Is the drive unit correctly aligned, i.e:
 - Is the mounting foot correctly oriented?
 - Is the drive mounted at right angles to the tiller arm, in a mid-stroke position, when the rudder is amidships?
 - Is the push rod accurately aligned with the tiller arm plane of rotation (less than 5 degrees variation)?
3. Is the linear drive rod end:
 - securely attached to the tiller arm or quadrant?
 - attached at the recommended tiller arm radius for the boat?
4. Are the motor and clutch cables correctly routed and securely connected to the course computer?
5. Have you completed a hand-steering check (see *page 11*)?

Note: *When you have installed the entire autopilot system, you will need to complete an autopilot steering check. Refer to the control unit handbook for more details.*

Maintenance

On a regular basis:

- check all connections and mountings are secure
- check drive alignment
- check cables for signs of wear or damage

Note: *If this drive is used heavily, we recommend that it is serviced every two years by a Raymarine Authorized Service Representative.*

EMC servicing and safety guidelines

- Raymarine equipment should be serviced only by authorized Raymarine service technicians. They will ensure that service procedures and replacement parts used will not affect performance. There are no user serviceable parts in any Raymarine product.
- Some products generate high voltages, so never handle the cables/connectors when power is being supplied to the equipment.

- When powered up, all electrical equipment produces electromagnetic fields. These can cause adjacent pieces of electrical equipment to interact with one another, with a consequent adverse effect on operation. In order to minimize these effects and enable you to get the best possible performance from your Raymarine equipment, guidelines are given in the installation instructions, to enable you to ensure minimum interaction between different items of equipment, i.e. ensure optimum Electromagnetic Compatibility (EMC).
- Always report any EMC-related problem to your nearest Raymarine dealer. We use such information to improve our quality standards.
- In some installations, it may not be possible to prevent the equipment from being affected by external influences. In general this will not damage the equipment but it can lead to spurious resetting action, or momentarily may result in faulty operation.

Product support

Raymarine products are supported by a worldwide network of distributors and Authorized Service Representatives.

If you encounter any difficulties with this product, please contact either your national distributor, or your service representative, or the **Raymarine Technical Services Call Center**. Refer to the back cover or the Worldwide Distributor List for contact details.

Raymarine Ltd

Anchorage Park
Portsmouth, Hampshire
England PO3 5TD
Telephone +44 (0)23 9269 3611
Fax +44 (0)23 9269 4642
www.raymarine.com

Raymarine Inc

22 Cotton Road, Suite 280
Nashua
NH 03063-4219, USA
Telephone +1 603 881 5200
Fax +1 603 864 4756
www.raymarine.com

**Raymarine Technical Services Call Center**

UK: +44 (0)23 9271 4713 or
+44 (0)23 9269 3611 ext. 1083

USA: +1 603 881 5200 or
1-800-539-5539 ext. 2333