

DCM100 DC Monitor

User's Manual

Revision 1.0

Copyright © 2008 Maretron, LLP All Rights Reserved

**Maretron, LLP
9014 N. 23rd Ave #10
Phoenix, AZ 85021-7850
<http://www.maretron.com>**

Maretron Manual Part #: M000026

Revision History

Revision	Description
1.0	Original document

Table of Contents

1	Introduction	1
1.1	Firmware Revision	1
1.2	DCM100 Features	1
1.3	Quick Install	1
2	Installation	2
2.1	Unpacking the Box	2
2.2	Choosing a Mounting Location	2
2.3	Mounting the DCM100	3
2.4	Connecting the DCM100	3
2.4.1	Connecting the DCM100 NMEA 2000® Interface	3
2.4.2	Connecting the DC power and Sensor Connections	4
2.4.3	Checking Connections	5
2.5	Configuring the DCM100	5
2.5.1	Instance Selection	6
2.5.2	Priority Selection	6
2.5.3	DC Type	6
2.5.4	Battery-Specific Options	6
2.5.4.1	Battery Type	6
2.5.4.2	Nominal Voltage	6
2.5.4.3	Equalization	7
2.5.4.4	Temperature Coefficient	7
2.5.4.5	Peukert Exponent	7
2.5.4.6	Charge Efficiency Factor	7
2.5.4.7	Fully Charged Voltage	7
2.5.4.8	Fully Charged Current	7
2.5.4.9	Fully Charged Time	7
2.5.4.10	Battery Temperature	7
2.5.4.11	Time Remaining Floor	8
2.5.4.12	Time Remaining Averaging Period	8
2.5.4.13	Zero Current Threshold	8
2.5.4.14	Current Sensor Zero Offset Calibration	8
2.5.5	NMEA 2000® PGN Enable/Disable	8
2.5.6	Restore Factory Defaults	8
3	Output Parameters	8
3.1	Parameters Common to DC Sources and Batteries	9
3.1.1	Battery Voltage	9
3.1.2	Battery Current	9
3.1.3	Ripple Voltage	9
3.1.4	Parameters Specific to Batteries	9
3.1.5	Battery Case Temperature	9
3.1.6	State of Charge	9
3.1.7	Time Remaining	9
4	Background	10
4.1	Why Monitor Batteries?	10
4.2	Batteries	10

4.3	Battery Capacity	10
4.4	Battery Types	10
4.5	Battery Safety Precautions	11
4.6	Charging Inefficiencies	11
4.6.1	Charge Efficiency Factor (CEF)	11
4.7	Discharging Inefficiencies	11
4.8	Peukert Exponent	11
5	Synchronization	12
5.1	Charge Efficiency Factor Calculation	12
6	Maintenance	12
7	Troubleshooting	13
8	Technical Specifications	14
9	Technical Support	15
10	Installation Template	16
11	Maretron (2 Year) Limited Warranty	17

Table of Figures

Figure 1 – Mounting the DCM100	3
Figure 2 – NMEA 2000® Connector Face Views	4
Figure 3 – Mounting Surface Template	16

Table of Appendices

Appendix A – NMEA 2000® Interfacing Translations	A1
--	----

1 Introduction

Congratulations on your purchase of the Maretron DC Monitor (DCM100). Maretron has designed and built your DC monitor to the highest standards for years of dependable and accurate service.

Maretron's DCM100 is a device which monitors DC power sources or batteries and outputs information about these sources onto the industry standard NMEA 2000® marine data network so that these data can be monitored with networked NMEA 2000® displays such as the Maretron DSM250 or with NMEA 2000® compatible software such as Maretron N2KView.

The Maretron DCM100 is designed to operate within the harsh demands of the marine environment. However, no piece of marine electronic equipment can function properly unless installed, configured, and maintained in the correct manner. Please read carefully and follow these instructions for installation, configuration, and usage of the Maretron DCM100 in order to ensure optimal performance.

1.1 Firmware Revision

This manual corresponds to DCM100 firmware revision 1.0.2.

1.2 DCM100 Features

The Maretron DCM100 has the following features.

- NMEA 2000® Interface
- Waterproof Connectors
- Sealed Waterproof Enclosure
- Opto-Isolated from NMEA 2000® Eliminating Potential Ground Loops
- Can monitor DC Power Sources, Transmitting Voltage and Current
- Can monitor Lead Acid and Gel Batteries, Transmitting Voltage, Current, Temperature, and State of Charge
- Uses Peukert's Constant and Charge Efficiency Factor for Accurate State of Charge Calculation
- Can Calculate Charge Efficiency Factor Based on Observed Battery Performance

1.3 Quick Install

Installing the Maretron DCM100 DC monitor involves the following five steps. Please refer to the individual sections for additional details.

1. Unpack the box (Section 2.1)
2. Choose a mounting location (Section 2.2)
3. Mount the DCM100 (Section 2.3)
4. Connect the DCM100 (Section 2.4)
5. Configure the DCM100 (Section 2.5)
6. Synchronize the DCM100 with the battery (Section 2.6)

2 Installation

2.1 Unpacking the Box

When unpacking the box containing the Maretron DCM100, you should find the following items:

- 1 – DCM100 – DC Monitor
- 1 – DC Current Sensor with 5 ft. long cable (Part # LEMHTA200-S) (outer cable covering grey)
- 1 – Battery Temperature Sensor with 5 ft. long cable (Part # TR3K) (outer cable covering grey)
- 1 – Battery Voltage Sense Cable, 5 ft. long (Part # FC01) (outer cable covering white)
- 1 – Power Cable, 5 ft. long (Part # FC01) (outer cable covering white)
- 1 – Parts Bag containing 4 Stainless Steel Mounting Screws
- 1 – DCM100 User's Manual
- 1 – Warranty Registration Card

If any of these items are missing or damaged, please contact Maretron.

2.2 Choosing a Mounting Location

The DCM100 should be mounted near the monitored source of DC power. Please consider the following when choosing a mounting location.

1. The DCM100 is waterproof, so it can be mounted in a damp or dry location.
2. The orientation is not important, so the DCM100 can be mounted on a horizontal deck, vertical bulkhead, or even upside down if desired.
3. The DCM100 is temperature rated to 55°C (130°F), so it should be mounted away from engines or engine rooms where the operating temperature exceeds the specified limit.

2.3 Mounting the DCM100

Attach the DCM100 securely to the vessel using the included stainless steel mounting screws or other fasteners as shown in Figure 1 below.

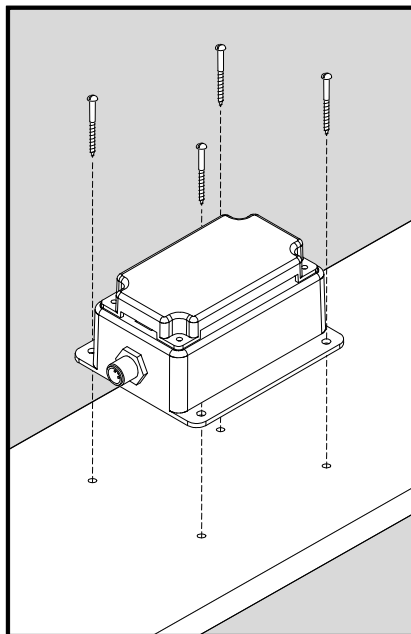

Figure 1 – Mounting the DCM100

2.4 Connecting the DCM100

The DCM100 requires two electrical connections as shown in . Refer to Section 2.4.1 for making the NMEA 2000® connection and Section 2.4.2 for making the DC monitor connections (i.e., current sensor, sensing voltage, and temperature sensor connections)..

2.4.1 Connecting the DCM100 NMEA 2000® Interface

Vertical text on the DCM100 label identifies the NMEA 2000® connector. With the label right side up, the NMEA 2000® connector can be found on the right side of the enclosure. The NMEA 2000® connector is a five pin male connector (see Figure 2). You connect the DCM100 to an NMEA 2000® network using a Maretron NMEA 2000® cable (or compatible cable) by connecting the female end of the cable to the DCM100 (note the key on the male connector and keyway on the female connector). Be sure the cable is connected securely and that the collar on the cable connector is tightened firmly. Connect the other end of the cable (male) to the NMEA 2000® network in the same manner. The DCM100 is designed such that you can plug or unplug it from an NMEA 2000® network while the power to the network is connected or disconnected. Please follow recommended practices for installing NMEA 2000® network products.

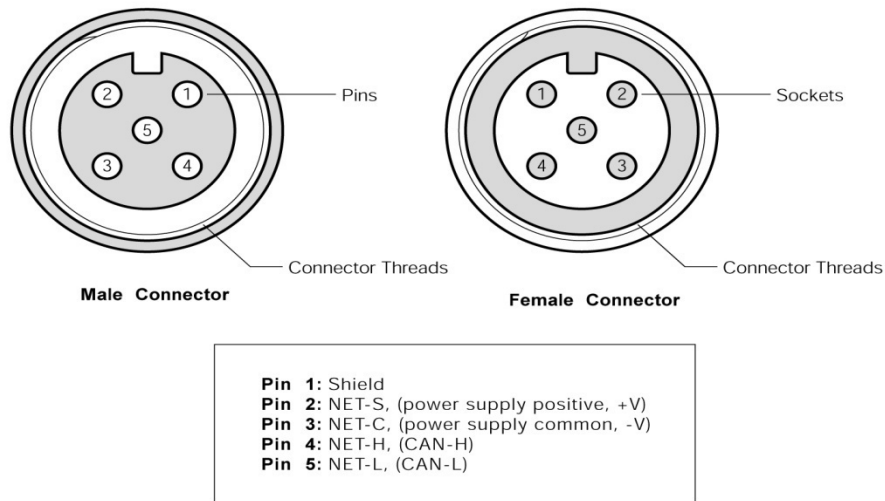

Figure 2 – NMEA 2000® Connector Face Views

2.4.2 Connecting the DC power and Sensor Connections

The DCM100's DC Power and sensor connections are made by connecting to the 12-pin terminal strip on the top of the unit. First, remove the four screws at the corners of the unit securing the splash guard to the unit. On the bottom of the splash guard, you will find a label detailing the wire connection to pin number assignments, which are repeated in the table below.

Pin Number	Signal Name	Connection
1	I_A	Current Sensor, Red Wire
2	I_B	Current Sensor, Green Wire
3	I_C	Current Sensor, Black Wire
4	I_D	Current Sensor, White Wire
5	V_{SENS+}	Battery, + Terminal
6	V_{SENS-}	Battery, - Terminal
7	V_{PWR-}	Vessel Ground
8	V_{PWR+}	9-16 V Power
9	No Connect	
10	No Connect	
11	T_A	Temperature Sender, Red Wire
12	T_B	Temperature Sender, Black Wire

Step 1: The Current Sensor (LEMHTA200-S) has a gray cable containing red, green, black, and white wires. Install the Current Sensor as follows:

- a. Connect the red wire to pin 1 (I_A) on the DCM100
- b. Connect the green wire to pin 2 (I_B) on the DCM100
- c. Connect the black wire to pin 3 (I_C) on the DCM100
- d. Connect the white wire to pin 4 (I_D) on the DCM100

- e. Disconnect the wire from the positive terminal of the battery or other DC source that is being monitored and place it through the hole in the Current Sensor such that the arrow on the Current Sensor points *towards* the battery or DC source. Then, reattach the wire to the positive terminal of the battery or other DC source.

Step 2: The temperature sensor (TR3K) has a gray cable containing red and black wires. Connect the Temperature Sensor as follows:

- a. Connect the red wire to pin 11 (T_A) on the DCM100
- b. Connect the black wire to pin 12 (T_B) on the DCM100
- c. Connect the ring terminal on the Temperature Sensor to the negative terminal of the battery being monitored

Step 3: The Battery Sense cable (FC01) is a white cable containing one red and one yellow wire (please note that the same type of cable is used both for the Battery Sense cable and for the Power cable). Install the Battery Sense cable as follows:

- a. Connect the yellow wire from one end of the cable to pin 6 (V_{SENS-}) on the DCM100.
- b. Connect the yellow wire from the other end of the cable to the negative terminal of the battery or DC source being monitored (NOTE: this may or may not be the same as the vessel ground)
- c. Connect the red wire from the first end of the cable to pin 5 (V_{SENS+}) on the DCM100
- d. Connect the red wire from the other end of the cable to the positive terminal of the battery or DC source being monitored

Step 4: The Power cable (FC01) is a white cable containing one red and one yellow wire. Install the DCM100 power cable as follows:

- a. Connect the yellow wire from one end of the cable to pin 7 (V_{PWR-}) on the DCM100.
- b. Connect the yellow wire from the other end of the cable to the vessel ground
- c. Connect the red wire from the first end of the cable to pin 8 (V_{PWR+}) on the DCM100.
- d. Connect the red wire from the other end of the cable to a source of 5?-36? VDC power (NOTE: this wire may nor may not be connected to the same place as the red wire from the Battery Sense cable).

2.4.3 Checking Connections

Once the NMEA 2000®, Current Sensor, Temperature Sensor, Voltage Sense, and DC Power connections to the DCM100 have been completed, check to see that information is being properly transmitted by observing an appropriate NMEA 2000® display. If you don't see DC power data, refer to Section 7, "Troubleshooting".

2.5 Configuring the DCM100

The DCM100 will transmit data over the NMEA 2000 network as it is shipped from the factory; however, it does require configuration in almost all cases for proper functioning. There are several configurable items within the DCM100, including: 1) NMEA 2000® DC power instance selection, 2) Priority Selection, 3) DC Type, 4) Battery Type, 5) Battery Capacity, 6) Nominal Voltage, 7) Equalization, 8) Temperature Coefficient, 9) Peukert Exponent, 10) Charge Efficiency Factor, 11) Fully Charged Voltage, 12) Fully Charged Current, 13) Fully Charged Time, 14) Battery Temperature, 15) Time Remaining Floor, 16) Time Remaining Averaging

Period, 17) Zero Current Threshold, 18) Manually Set Battery to 100%, 19) Current Sensor Zero Offset Calibration, and 20) NMEA 2000 PGN Enable/Disable.

2.5.1 Instance Selection

NMEA 2000® provides a unique engine instance for each DC power source on a vessel. You configure the DCM100 using a Maretron DSM250 display or other NMEA 2000® display unit that is capable of configuring the DCM100. Please refer to the Maretron *DSM250 User's Manual* for details.

2.5.2 Priority Selection

NMEA 2000® can provide a unique priority for allowing multiple, redundant sensors for a single DC power source on a vessel. If you have only one DCM100 on a particular DC power source, you should leave the priority selection at the default value of zero. You configure the DCM100 using a Maretron DSM250 display or other NMEA 2000® display unit that is capable of configuring the DCM100. Please refer to the Maretron *DSM250 User's Manual* for details.

2.5.3 DC Type

You can configure the DCM100 as to what type of DC power source it is monitoring. With the exception of the "Battery" type, the value of this parameter is used only for reporting the power source type over the NMEA 2000 network. However, if you select the "Battery" type, many battery-related options become available. You configure the DCM100 using a Maretron DSM250 display or other NMEA 2000® display unit that is capable of configuring the DCM100. Please refer to the Maretron *DSM250 User's Manual* for details.

The following DC Types are selectable:

- Battery (See Section 2.5.4 for options that are enabled when this type is selected)
- Alternator
- Converter
- Solar Cell
- Wind Generator

2.5.4 Battery-Specific Options

The options in this section are available only if the "DC Type" parameter is set to "Battery".

2.5.4.1 Battery Type

The available battery types are "Flooded/Wet", "Gel", "AGM", and "Other". Selecting one of these types causes the remaining parameters to be set to appropriate default values.

2.5.4.2 Nominal Voltage

You may program here the nominal voltage of the battery, which is used only for reporting over the NMEA 2000 network. Available choices are 6, 12, 24, 32, 36, 42, and 48 Volts.

2.5.4.3 Equalization

You may indicate here whether or not the battery supports equalization. This is used only for reporting over the NMEA 2000 network. Available choices are “Supported” and “Not Supported”.

2.5.4.4 Temperature Coefficient

The capacity of a battery generally increases with increasing temperature. So that the DCM100 can properly calculate the battery's state of charge, program this parameter with the increase in battery capacity, in percent, per increase in temperature, in degrees Celsius. The temperature coefficient can be set to a value between 0%/°C – 5%/°C.

2.5.4.5 Peukert Exponent

The Peukert Exponent for the battery can be set to a value between 1.0 and 1.5. Please refer to Section 4.8 on page 11 for details.

2.5.4.6 Charge Efficiency Factor

The Charge Efficiency Factor for the battery can be set to a value between 5% and 100%. Please refer to Section 4.6.1 on page 11 for details.

2.5.4.7 Fully Charged Voltage

In order for the DCM100 to determine when a battery is fully charged, it uses three parameters. The “Fully Charged Voltage” indicates the value voltage at which the battery is considered fully charged if the battery voltage remains above this value and the battery current remains below the “Fully Charged Current” for the amount of time defined by the “Fully Charged Time” parameter.

2.5.4.8 Fully Charged Current

In order for the DCM100 to determine when a battery is fully charged, it uses three parameters. The “Fully Charged Voltage” indicates the value voltage at which the battery is considered fully charged if the battery voltage remains above this value and the battery current remains below the “Fully Charged Current” for the amount of time defined by the “Fully Charged Time” parameter.

2.5.4.9 Fully Charged Time

In order for the DCM100 to determine when a battery is fully charged, it uses three parameters. The “Fully Charged Voltage” indicates the value voltage at which the battery is considered fully charged if the battery voltage remains above this value and the battery current remains below the “Fully Charged Current” for the amount of time defined by the “Fully Charged Time” parameter.

2.5.4.10 Battery Temperature

In order for the DCM100 to properly determine battery capacity and state of charge, it must know the temperature of the battery. If you are using a TR3K temperature sensor attached to the battery, you should set this parameter to “Sensor”. Otherwise, if no temperature sensor is

available, you can set this parameter to the estimated battery temperature, between -25°C and 125°C.

2.5.4.11 Time Remaining Floor

The DCM100 calculates the time, given the current being discharged from the battery, before the battery becomes discharged. By default, the DCM100 considers a battery to be discharged when its state of charge reaches the “Time Remaining Floor” value, which is by default set to 50%. If you desire to use some other state of charge value for the “Time Remaining Floor”, you may change this parameter to the desired value.

2.5.4.12 Time Remaining Averaging Period

If loads on the battery are switching on and off frequently, the battery time remaining value calculated by the DCM100 can vary significantly. You may change the time over which current readings are averaged by changing this parameter anywhere in the range of 1 second to 32 minutes.

2.5.4.13 Zero Current Threshold

The current sensor reading can drift slightly at zero current, depending on temperature. Over a long period of time, this can cause the DCM100 to calculate that a battery is discharging slowly, even though it is not. The Zero Current Threshold parameter indicates a reading from the current sensor below which no current is considered to be flowing into or out of the battery.

2.5.4.14 Current Sensor Zero Offset Calibration

The DCM100 is shipped with a Hall-effect current sensor. In order to match the DCM100 unit and the sensor to one another and ensure maximum accuracy, you should perform this calibration step while there is no current flowing through the current sensor.

2.5.5 NMEA 2000[®] PGN Enable/Disable

The DCM100 is capable of transmitting two different kinds of NMEA 2000[®] messages (or PGNs) associated with DC sources and batteries. You may individually enable or disable each of these messages. You can configure the DCM100 using a Maretron DSM250 display or other NMEA 2000[®] display unit that is capable of configuring the DCM100. Please refer to the Maretron *DSM250 User's Manual* for details.

2.5.6 Restore Factory Defaults

Selecting this configuration option causes all stored parameters in the DCM100 to be reset to the values they contained when the unit was manufactured.

3 Output Parameters

The DCM100 outputs a variety of information about the DC source or battery onto the NMEA 2000 network.

3.1 Parameters Common to DC Sources and Batteries

The parameters in this section are transmitted regardless of the “DC Type” selected (see Section 2.5.3 for details).

3.1.1 Battery Voltage

This parameter indicates the voltage present across the battery terminals.

3.1.2 Battery Current

This parameter indicates the voltage being supplied to the battery, in the case of charging, or being supplied from the battery, in the case of discharging. Charging current is represented as a positive value, while discharging current is represented as a negative value.

3.1.3 Ripple Voltage

This parameter indicates the magnitude of the AC voltage component of the battery or DC-source. Ideally, the ripple voltage should read zero. Excessive ripple voltage may cause functional problems in devices which draw power from the DC power source.

3.1.4 Parameters Specific to Batteries

The parameters in this section are transmitted only if the “DC Type” parameter is set to a value of “Battery” (see Section 2.5.3 for details).

3.1.5 Battery Case Temperature

This parameter indicates the present temperature indicated at the temperature sensor, which should be attached to the battery’s negative terminal.

3.1.6 State of Charge

This parameter indicates how much energy is contained in the battery. The reading ranges from 0%, which indicates a completely flat battery, to 100%, which indicates a completely charged battery.

3.1.7 Time Remaining

This parameter indicates how long the battery can supply the present current before becoming discharged. The value of state of charge which is used to calculate the discharged state for this parameter can be adjusted by changing the “Time Remaining Floor” parameter (see Section 2.5.4.11 on page 8 for details). This reading may fluctuate significantly as loads are added to or subtracted from the battery, so the damping may be adjusted by changing the “Time Remaining Averaging Period” parameter (see Section 2.5.4.12 on page 8 for details).

4 Background

4.1 Why Monitor Batteries?

The lifetime and storage capacity of batteries can be greatly affected by the way in which they are used. Discharging a battery excessively or under-charging or over-charging a battery can ruin it. A battery monitor can help you monitor and adjust your battery usage to extend a battery's lifetime to the maximum possible. In addition, a battery monitor can help you to determine the amount of energy stored in your batteries in order to plan energy usage and charge cycles, and can help you to monitor the health of your batteries to determine when they need to be replaced.

4.2 Batteries

A battery stores electrical energy in the form of chemical energy. Batteries are not 100% efficient. Not all electrical energy put into the battery during charging is stored in the battery as chemical energy, and not all chemical energy stored in the battery is converted to electrical energy during discharge.

4.3 Battery Capacity

The capacity of a battery is specified in Amp-hours. A battery that delivers one Ampere of current for one hour has delivered one Amp-hour. The capacity of a marine deep-cycle battery is specified based on the amount of current it can deliver to go from a fully-charged state to a fully-discharged state (battery voltage has dropped to 10.5 volts). For example, a battery that becomes fully discharged after twenty hours of delivering 5 amperes of current is rated as a (5 amperes x 20 hours) 100 Amp-hour battery.

The capacity of a battery is affected by the temperature of the battery. In general, for lead-acid batteries, the capacity of a battery increases with higher temperature. The DCM100 accounts for this by using the "Temperature Coefficient" parameter.. This parameter is expressed in units of percentage per degree Celsius. For example, a Battery Capacity Temperature Coefficient value of 0.5 %/°C means that, if the Charge Efficiency Factor were 80 Amp-Hours at 25°C, then at 26°C, the CEF would increase to 80.4 Amp-Hours.

4.4 Battery Types

Almost all batteries used in marine applications are of the Lead-Acid type. There are three main types of Lead-Acid batteries, depending on the form of the electrolyte. When the electrolyte is stored in liquid form, the batteries are called "Flooded", "Wet", or sometimes, simply "Lead-Acid". When the electrolyte is stored in a gel form, the batteries are called "Gel" batteries. When the electrolyte is stored absorbed into fiberglass mats, the batteries are called "AGM", or "Absorbent Glass Mat", batteries. These batteries have different properties, and the DCM100 can monitor all three of these battery types. When you set the "Battery Type" parameter, the DCM100 sets remaining battery measurement parameters to values which are representative of the selected battery type (see Section 2.5.4.1 on page 6 for details).

4.5 Battery Safety Precautions

1. Lead-acid batteries generate explosive gases during operation. Make sure that the area around the batteries is well-ventilated. Never allow flames or sparks near a battery.
2. Wear clothing and eye protection when working with batteries. If battery acid comes into contact with your skin or clothing, wash them immediately with soap and water. If battery acid contacts your eyes, immediately rinse your eyes with cool running water for at least 15 minutes, and immediately seek medical attention.
3. Be careful when using metal tools on or around batteries. If a metal tool falls between the battery terminals, it can cause a short-circuit which can generate sparks, igniting fuel fumes, or may also cause the battery to explode.
4. Remove metal items like watches, necklaces, rings, and bracelets when working with batteries. If these items were to contact the battery terminals, the resulting short-circuit could produce a current which could melt the objects and possibly cause severe skin burns.

4.6 Charging Inefficiencies

When charging a battery, not all of the electrical energy put into the battery is stored as chemical energy. This section details how the DCM100 accounts for this type of inefficiency.

4.6.1 Charge Efficiency Factor (CEF)

The Charge Efficiency Factor (CEF) represents the percentage of electrical energy that is put into a battery that is stored as electrical energy, measured at 25°C. An ideal battery would have a charge efficiency factor of 1.0, or 100%. A new flooded lead-acid battery may have a CEF of 0.95, or 95%. This value means that if 100 Amp-hours of energy are put into a battery by a charger, this results in the battery's charge increasing by only 95 Amp-hours. The DCM100 is capable of calculating a battery's charge efficiency factor on the fly, as the battery is being charged and discharged, to produce the most accurate state of charge values.

4.7 Discharging Inefficiencies

In an ideal battery, 100% of the energy in the battery would be available no matter what discharge current is used. However, with lead-acid batteries, the energy available from a battery depends on the rate at which a battery is discharged – the faster you discharge the battery, the less energy is available.

The Amp-hour capacity of most batteries is specified using a 20-hour rate; that is, the Amp-hour capacity rating of the battery is calculated if the battery is discharged from 100% to 0% using a constant current over the period of 20 hours. If the battery is discharged at a faster rate, then it will output less than the rated Amp-hour capacity before becoming fully discharged.

4.8 Peukert Exponent

This effect was presented by a German scientist, W. Peukert, in 1897. He formulated an equation which closely approximates the effect of discharge rate on battery capacity. A

restated version of the equation, which allows you to calculate the time to totally discharge a given battery at a given discharge current, follows:

$$T = R \left(\frac{C}{IR} \right)^n,$$

where

C = the rated battery capacity in Amp-hours,

R = the number of hours over which the rated battery capacity was calculated (usually 20),

I = the discharge current in Amperes,

T = the time to discharge the battery in hours, and

n = the Peukert constant for the battery (dimensionless).

The Peukert constant for an ideal battery is 1.0. For lead-acid batteries, the value of the Peukert constant is in the range of 1.10 – 1.25.

The DCM100 takes the Peukert effect into account when calculating the state of charge of a battery.

Please contact the manufacturer of your battery to obtain the Peukert's constant for the battery to which you are connecting the DCM100.

5 Synchronization

In order to keep state of charge readings as accurate as possible, the DCM100 must periodically (once per month is recommended) be synchronized with the battery. This is done by fully charging the battery. When the battery is at the "Fully Charged Voltage" and the current flowing into the battery is below the "Fully Charged Current" threshold for more than the "Fully Charged Time", the DCM100 sets the state of charge of the battery 100% (see Sections 2.5.4.7, 2.5.4.8, and 2.5.4.9 starting on page 7 for details).

5.1 Charge Efficiency Factor Calculation

The battery must first be discharged below the synchronization threshold state of charge. The battery must then be fully charged.

At this point, if the "Charge Efficiency Factor" is set to "Auto", the DCM100 re-calculates the Charge Efficiency Factor based on the amount of energy which flowed into the battery during the charging cycle. This new Charge Efficiency Factor value is used for further charging cycles. Alternatively, you may manually set the value of the "Charge Efficiency Factor" (see Section 2.5.4.6 on page 7 for details).

6 Maintenance

Regular maintenance is important to ensure continued proper operation of the Maretron DCM100. Perform the following tasks periodically:

- Clean the unit with a soft cloth. Do not use chemical cleaners as they may remove paint or markings or may corrode the DCM100 enclosure or seals.
- Ensure that the unit is mounted securely and cannot be moved relative to the mounting surface. If the unit is loose, tighten the mounting screws.
- Check the security of the cable connected to the NMEA 2000® connector, and tighten if necessary.
- Check the security of all of the battery connections, current sensor connections, and temperature connections on the top of the unit and tighten if necessary.

7 Troubleshooting

If you notice unexpected operation of the Maretron DCM100, follow the troubleshooting procedures in this section to remedy simple problems. If these steps do not solve your problem, please contact Maretron Technical Support (refer to Section 9 for contact information).

Symptom	Troubleshooting Procedure
No DC power data visible on NMEA 2000® network.	<p>Ensure that the DCM100 is properly connected to the NMEA 2000® network.</p> <p>Ensure that the battery voltage, current sensor, and temperature sensors are properly connected to the DCM100.</p> <p>Ensure that the DCM100 has the appropriate NMEA 2000® PGNs enabled as described in Section 2.5.4.14.</p>
Battery State of Charge shows 100% before the charge cycle is finished	<p>Ensure that the Peukert exponent you have entered for the battery is correct.</p> <p>Synchronize the DCM100 with the battery.</p>
Battery State of Charge jumps from 95% or lower to 100% when the charge cycle is finished	<p>Ensure that the Peukert exponent you have entered for the battery is correct.</p> <p>Synchronize the DCM100 with the battery.</p>
Battery State of Charge decreases while charging and increases while discharging	<p>The current sensor is installed incorrectly. Reverse the direction of the wire through the current sensor.</p>

Warning: There are no user-serviceable components inside the Maretron DCM100. Opening the DCM100 will expose the sensitive electronic components to adverse environmental conditions that may render the unit inoperative. Please do not open the DCM100, as this will

automatically void the warranty. If service is required, please return the unit to an authorized Maretron service location.

8 Technical Specifications

As Maretron is constantly improving its products, all specifications are subject to change without notice. Maretron products are designed to be accurate and reliable; however, they should be used only as aids to navigation and not as a replacement for traditional navigation aids and techniques.

Certifications

Parameter	Comment
NMEA 2000®	Level A
Maritime Navigation and Radiocommunication Equipment & Systems	IEC 60945
FCC and CE Mark	Electromagnetic Compatibility

NMEA 2000® Parameter Group Numbers (PGNs)

Description	PGN #	PGN Name	Default Rate
Periodic Data PGNs	127506	DC Detailed Status	0.67 times/second
	127508	Battery Status	0.67 times/second
	127513	Battery Configuration Status	N/A
Response to Requested PGNs	126464	PGN List (Transmit and Receive)	N/A
	126996	Product Information	N/A
	126998	Configuration Information	N/A
Protocol PGNs	059392	ISO Acknowledge	N/A
	059904	ISO Request	N/A
	060928	ISO Address Claim	N/A
	065240	ISO Address Command	N/A
	126208	NMEA	N/A
Maretron Proprietary PGNs	128720	Configuration	N/A

Electrical

Parameter	Value	Comment
Operating Voltage	9 to 16 Volts	DC Voltage
Power Consumption	70 mA 30 mA	V_{PWR+} , V_{PWR-} NMEA 2000 Interface
Load Equivalence Number (LEN)	1	NMEA 2000® Spec. (1LEN = 50 mA)
Reverse Battery Protection	Yes	Indefinitely
Load Dump Protection	Yes	Energy Rated per SAE J1113

Mechanical

Parameter	Value	Comment
Size	3.50" x 4.20" x 2.03" (88.9mm x 106.7mm x 51.6mm)	Including Flanges for Mounting
Weight	13 oz. (368.5 g)	

Environmental

Parameter	Value
IEC 60954 Classification	Exposed
Degree of Protection	IP64
Operating Temperature	-25°C to 55°C
Storage Temperature	-40°C to 70°C
Relative Humidity	93%RH @40° per IEC60945-8.2
Vibration	2-13.2Hz @ ±1mm, 13.2-100Hz @ 7m/s2 per IEC 60945-8.7
Rain and Spray	12.5mm Nozzle @ 100liters/min from 3m for 30min per IEC 60945-8.8?
Solar Radiation	Ultraviolet B, A, Visible, and Infrared per IEC 60945-8.10
Corrosion (Salt Mist)	4 times 7days @ 40°C, 95%RH after 2 hour Salt Spray Per IEC 60945-8.12
Electromagnetic Emission	Conducted and Radiated Emission per IEC 60945-9
Electromagnetic Immunity	Conducted, Radiated, Supply, and ESD per IEC 60945-10
Safety Precautions	Dangerous Voltage, Electromagnetic Radio Frequency per IEC 60945-12

9 Technical Support

If you require technical support for Maretron products, you can reach us in any of the following ways:

Telephone: 1-866-550-9100
Fax: 1-602-861-1777
E-mail: support@maretron.com
World Wide Web: <http://www.maretron.com>
Mail: Maretron, LLC
Attn: Technical Support
9014 N. 23rd Ave Suite 10
Phoenix, AZ 85021 USA

10 Installation Template

Please check the dimensions before using the following diagram as a template for drilling the mounting holes because the printing process may have distorted the dimensions.

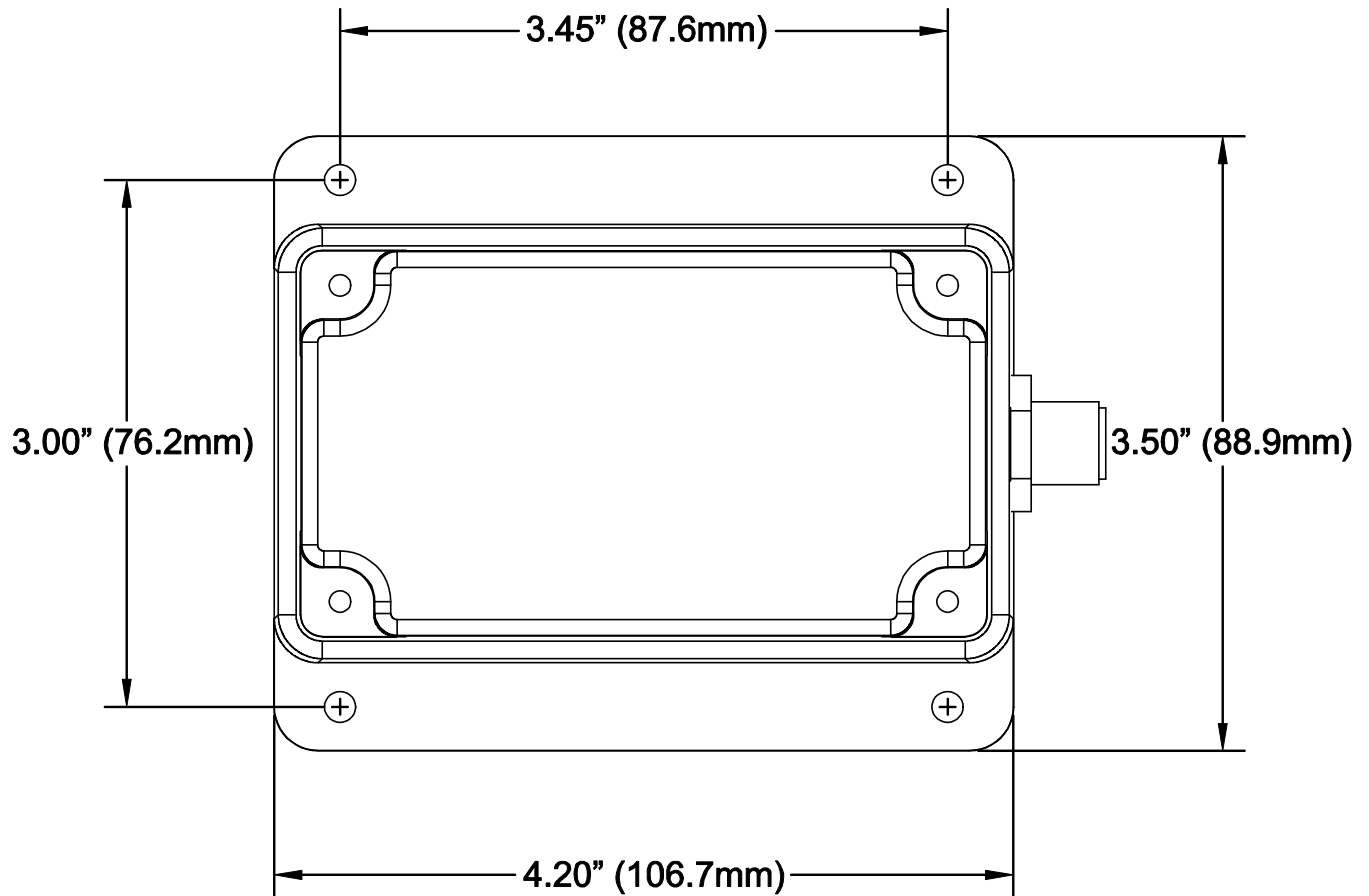

Figure 3 – Mounting Surface Template

11 Maretron (2 Year) Limited Warranty

Maretron warrants the DCM100 to be free from defects in materials and workmanship for **two (2) years** from the date of original purchase. If within the applicable period any such products shall be proved to Maretron's satisfaction to fail to meet the above limited warranty, such products shall be repaired or replaced at Maretron's option. Purchaser's exclusive remedy and Maretron's sole obligation hereunder, provided product is returned pursuant to the return requirements below, shall be limited to the repair or replacement, at Maretron's option, of any product not meeting the above limited warranty and which is returned to Maretron; or if Maretron is unable to deliver a replacement that is free from defects in materials or workmanship, Purchaser's payment for such product will be refunded. Maretron assumes no liability whatsoever for expenses of removing any defective product or part or for installing the repaired product or part or a replacement therefore or for any loss or damage to equipment in connection with which Maretron's products or parts shall be used. With respect to products not manufactured by Maretron, Maretron's warranty obligation shall in all respects conform to and be limited to the warranty actually extended to Maretron by its supplier. The foregoing warranties shall not apply with respect to products subjected to negligence, misuse, misapplication, accident, damages by circumstances beyond Maretron's control, to improper installation, operation, maintenance, or storage, or to other than normal use or service.

THE FOREGOING WARRANTIES ARE EXPRESSLY IN LIEU OF AND EXCLUDES ALL OTHER EXPRESS OR IMPLIED WARRANTIES, INCLUDING BUT NOT LIMITED TO THE IMPLIED WARRANTIES OF MERCHANTABILITY AND OF FITNESS FOR A PARTICULAR PURPOSE.

Statements made by any person, including representatives of Maretron, which are inconsistent or in conflict with the terms of this Limited Warranty, shall not be binding upon Maretron unless reduced to writing and approved by an officer of Maretron.

IN NO CASE WILL MARETRON BE LIABLE FOR INCIDENTAL OR CONSEQUENTIAL DAMAGES, DAMAGES FOR LOSS OF USE, LOSS OF ANTICIPATED PROFITS OR SAVINGS, OR ANY OTHER LOSS INCURRED BECAUSE OF INTERRUPTION OF SERVICE. IN NO EVENT SHALL MARETRON'S AGGREGATE LIABILITY EXCEED THE PURCHASE PRICE OF THE PRODUCT(S) INVOLVED. MARETRON SHALL NOT BE SUBJECT TO ANY OTHER OBLIGATIONS OR LIABILITIES, WHETHER ARISING OUT OF BREACH OF CONTRACT OR WARRANTY, TORT (INCLUDING NEGLIGENCE), OR OTHER THEORIES OF LAW WITH RESPECT TO PRODUCTS SOLD OR SERVICES RENDERED BY MARETRON, OR ANY UNDERTAKINGS, ACTS OR OMISSIONS RELATING THERETO.

Maretron does not warrant that the functions contained in any software programs or products will meet purchaser's requirements or that the operation of the software programs or products will be uninterrupted or error free. Purchaser assumes responsibility for the selection of the software programs or products to achieve the intended results, and for the installation, use and results obtained from said programs or products. No specifications, samples, descriptions, or illustrations provided Maretron to Purchaser, whether directly, in trade literature, brochures or other documentation shall be construed as warranties of any kind, and any failure to conform with such specifications, samples, descriptions, or illustrations shall not constitute any breach of Maretron's limited warranty.

Warranty Return Procedure:

To apply for warranty claims, contact Maretron or one of its dealers to describe the problem and determine the appropriate course of action. If a return is necessary, place the product in its original packaging together with proof of purchase and send to an Authorized Maretron Service Location. You are responsible for all shipping and insurance charges. Maretron will return the replaced or repaired product with all shipping and handling prepaid except for requests requiring expedited shipping (i.e. overnight shipments). Failure to follow this warranty return procedure could result in the product's warranty becoming null and void.

Maretron reserves the right to modify or replace, at its sole discretion, without prior notification, the warranty listed above. To obtain a copy of the then current warranty policy, please go to the following web page:

<http://www.maretron.com/company/warranty.php>

Appendix A – NMEA 2000® Interfacing

DCM100 NMEA 2000® Periodic Data Transmitted PGNs

PGN 127506 – DC Detailed Status

The DCM100 uses this PGN to transmit slowly changing DC and Battery Data

- Field 1: SID – The sequence identifier field is used to tie related PGNs together. For example, the DCM100 will transmit identical SIDs for 127506 (DC Detailed Status) and 127508 (Battery Status) to indicate that the readings are linked together (i.e., the data from each PGN was taken at the same time although they are reported at slightly different times).
- 2: DC Instance – This field indicates the particular DC source or battery for which this data applies. A single battery will have an instance of 0. Batteries in boats with multiple batteries will be numbered uniquely, starting at 0.
 - 3: DC Type – This field indicates the type of DC source being monitored. The DCM100 indicates one of the following values: 0=Battery, 1=Alternator, 2=Convertor, 3=Solar Cell, 4=Wind Generator.
 - 4: State of Charge – This field indicates the state of charge of a battery in units of 1%.
 - 5: State of Health – This field always contains a value of 0 (no State of Health calculation).
 - 6: Time Remaining – This field indicates the time remaining to the discharge floor at the current rate of discharge in units of 1 minute.
 - 7: Ripple Voltage – This field indicates the amplitude of AC ripple present on the DC voltage source in units of 1 mV.

PGN 127508 – Battery Status

The DCM100 uses this PGN to transmit slowly changing Battery Data.

- Field 1: Battery Instance – This field indicates the particular battery for which this data applies. A single battery will have an instance of 0. Batteries in boats with multiple batteries will be numbered uniquely, starting at 0.
- 2: Battery Voltage – This field indicates the voltage of the battery in units of 10 mV.
 - 3: Battery Current – This field indicates the current flowing through the battery in units of 0.1A. Positive values denote that charging current, negative values denote discharge current.
 - 4: Battery Case Temperature – This field indicates the temperature of the battery's case in units of 0.01°K.
 - 5: SID – The sequence identifier field is used to tie related PGNs together. For example, the DCM100 will transmit identical SIDs for 127506 (DC Detailed Status) and 127508 (Battery Status) to indicate that the readings are linked together (i.e., the data from each PGN was taken at the same time although they are reported at slightly different times).

PGN 127508 – Battery Configuration Status

The DCM100 uses this PGN to transmit unchanging battery configuration data.

- Field 1: Battery Instance – This field indicates the particular battery for which this data applies. A single battery will have an instance of 0. Batteries in boats with multiple batteries will be numbered uniquely, starting at 0.
- 2: Battery Type – This field indicates the type of battery. The DCM100 indicates one of the following values: 0=Flooded, 1=Gel, 2=AGM.
- 3: Supports Equalization – This field indicates whether the battery supports an equalization charge. The DCM will always transmit a value of 0 for this field.
- 4: Reserved – This field is reserved by NMEA; therefore, the DCM100 sets all bits to a logic 1.
- 5: Nominal Voltage – This field indicates the nominal voltage of the battery. The DCM100 indicates one of the following values: 0=6 Volts, 1=12 Volts, 2=24 Volts, 3=32 Volts, 4=36 Volts, 5=42 Volts, 6=48 Volts.
- 6: Battery Chemistry – This field indicates the chemistry of the battery. The DCM100 indicates one of the following values: 0=Lead Acid, 1=Lilon, 2=NiCad, 3=ZnO, 3=NiMH.
- 7: Battery Capacity – This field indicates the capacity of the battery in units of 1 amp-hour.
- 8: Battery Temperature Coefficient – This field indicates the increase of battery capacity with increasing temperature in units of 1%/°C.
- 9: Peukert Exponent – This field indicates the Peukert exponent of the battery with a resolution of 0.002 (unitless).
- 10: Charge Efficiency Factor – This field indicates the charge efficiency factor of the battery in units of 1%.