

GPS100 GPS/WAAS Antenna/Receiver

User's Manual

Revision 1.2

Copyright © 2005 Maretron, LLC All Rights Reserved

**Maretron, LLC
9034 N. 23rd Ave #13
Phoenix, AZ 85021-7850
<http://www.maretron.com>**

Maretron Manual Part #: M000301

Revision History

Revision	Description
1.0	Original document.
1.1	Minor editorial changes. Added description of variation output in several locations.
1.2	Added reference to GPS100 firmware release (1.1) Added references for disabling periodic rate (3.0, Appendix A)

Table of Contents

1	Introduction	1
1.1	Firmware Revision	1
1.2	GPS100 Features	1
2	Installation	1
2.1	Unpacking the Box	1
2.2	Choosing a Mounting Location	1
2.3	Mounting the GPS100	2
2.3.1	Mounting the GPS100 to a Horizontal Surface	2
2.3.2	Mounting the GPS100 to a Standard Marine Pole Mount	3
2.4	Connecting the GPS100	4
2.4.1	Checking Connections	5
3	Operation	5
3.1	Magnetic Variation	5
4	Maintenance	6
5	Troubleshooting	7
6	Technical Specifications	7
7	Technical Support	9
8	Installation Template	10
9	Maretron (2 Year) Limited Warranty	11

Table of Figures

Figure 1	– Mounting the GPS100 to a flat surface	2
Figure 2	– Mounting the GPS100 to a Standard Marine Pole Mount	3
Figure 3	– GPS100 Interface Connector	4
Figure 4	– NMEA 2000® Connector Face Views	4
Figure 5	– Horizontal Mounting Surface Template	10

Table of Appendices

Appendix A	– NMEA 2000 Interfacing	A1
------------	-------------------------------	----

This page intentionally left blank.

1 Introduction

Congratulations on your purchase of the Maretron GPS100 GPS/WAAS Antenna/Receiver. Maretron has designed and built your GPS100 to the highest standards for years of reliable, dependable, and accurate service.

The Maretron GPS100 is designed to operate within the harsh demands of the marine environment. However, no piece of marine electronic equipment can function properly unless installed and maintained in the correct manner. Please read carefully and follow these instructions for installation and usage of the Maretron GPS100 in order to ensure optimal performance.

1.1 Firmware Revision

This manual corresponds to GPS100 firmware revision 1.5.

1.2 GPS100 Features

The Maretron GPS100 has the following features.

- NMEA 2000® Interface
- 12 Channel GPS Antenna/Receiver
- Satellite Based Augmentation System (SBAS) capable (WAAS, EGNOS and MSAS)
- Accurate Location, COG and SOG Data to Any NMEA 2000® Device Including Chart Plotters, Autopilots, and Instrumentation Displays
- Magnetic Variation Output Based on World Magnetic Model (WMM2005)
- Waterproof Enclosure and Cable System

2 Installation

2.1 Unpacking the Box

When unpacking the box containing the Maretron GPS100, you should find the following items:

- 1 - GPS100 GPS/WAAS Antenna/Receiver
- 1 - Pole Mount Base
- 3 - Mounting Screws and Lock Washers
- 1 - GPS100 User's Manual
- 1 - Warranty Registration Card

If any of these items are missing or damaged, please contact Maretron.

2.2 Choosing a Mounting Location

The selection of a suitable mounting location is important for the optimal performance of the Maretron GPS100. The mounting location and orientation of the GPS100 should be:

1. *Level with the earth's horizontal plane* – This gives the GPS100 antenna the optimal view of satellites from all directions.

2. *High Enough to have a clear view of the sky to the horizon in all directions unblocked by masts or antennas* – The GPS100 provides the best readings when it has access to as many satellites as possible.
3. *As far as possible from VHF, satellite, or radar antennas* – Radio frequency transmissions from these antennas can interfere with the proper reception of GPS satellite signals by the GPS100.

2.3 Mounting the GPS100

The Maretron GPS100 can be mounted directly on top of a horizontal surface (Section 2.3.1) or on top of a 1" 14 threads per inch standard marine pole mount (Section 2.3.2).

2.3.1 Mounting the GPS100 to a Horizontal Surface

Attach the GPS100 securely to the vessel using the included brass mounting screws and included lock washers or other fasteners as shown in Figure 1 (see mounting template in Section 8 for drill pattern).

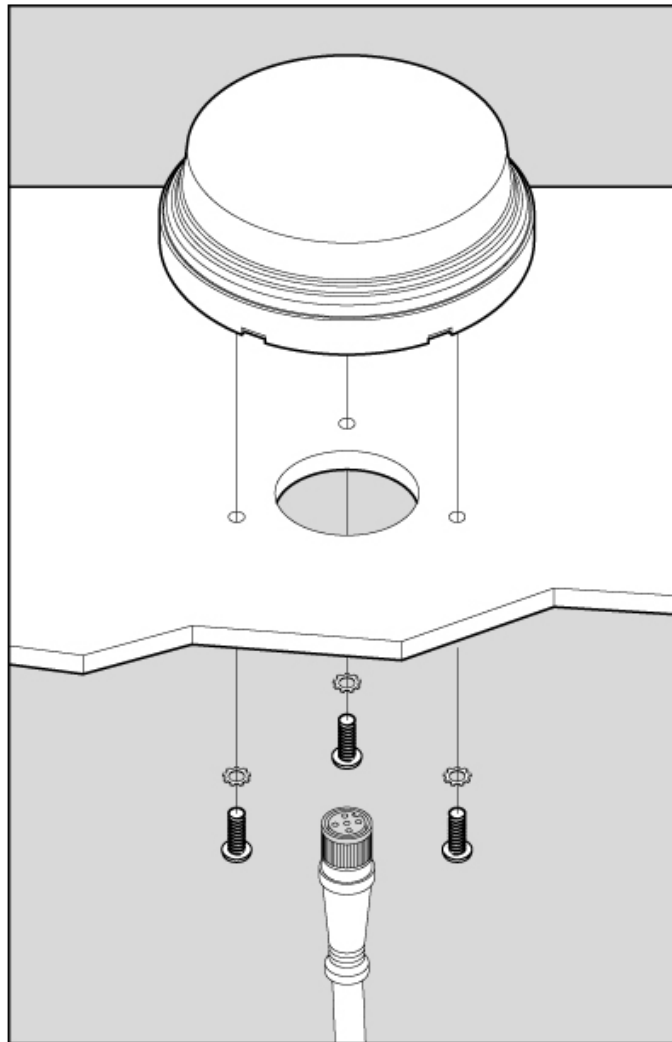

Figure 1 – Mounting the GPS100 to a flat surface

2.3.2 Mounting the GPS100 to a Standard Marine Pole Mount

Screw the included GPS100 antenna mount base to the standard marine mount. Thread the NMEA 2000® cable through the standard marine mount and the antenna mount base from the bottom out through the top and connect it to the GPS100 unit (see Section 2.4 below). Finally, attach the GPS100 to the antenna mount base using the included brass mounting screws and lock washers as shown in Figure 2.

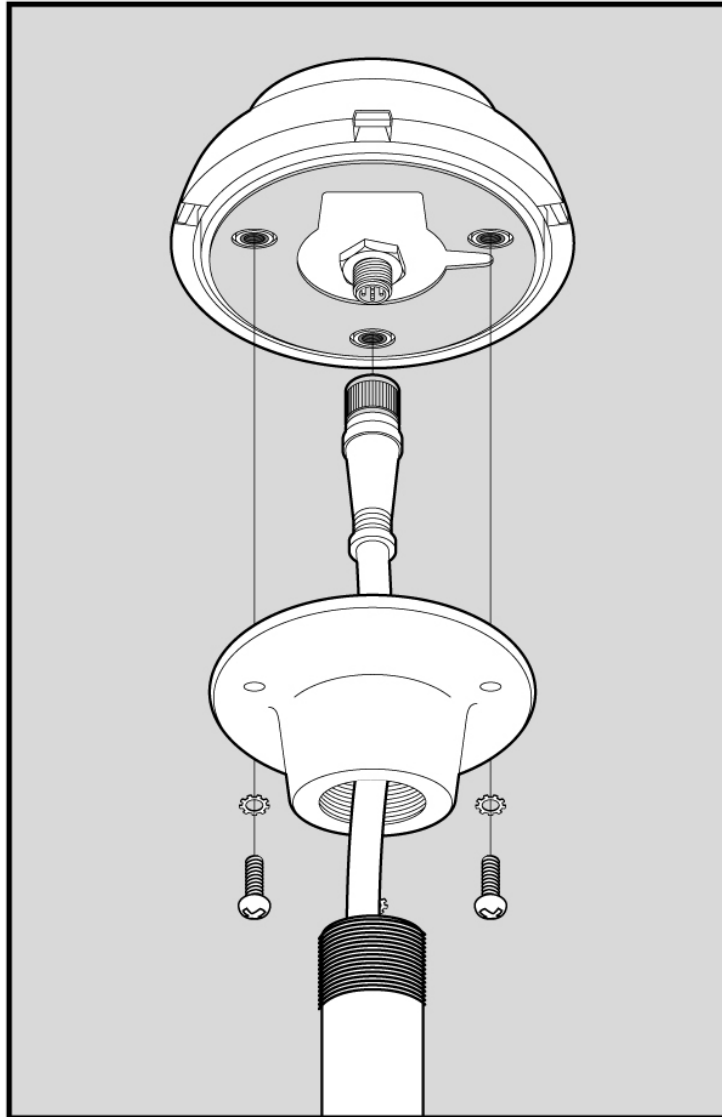

Figure 2 – Mounting the GPS100 to a Standard Marine Pole Mount

2.4 Connecting the GPS100

The Maretron GPS100 provides a connection to an NMEA 2000[®] interface through a connector that can be found on the bottom of the device (see Figure 3).

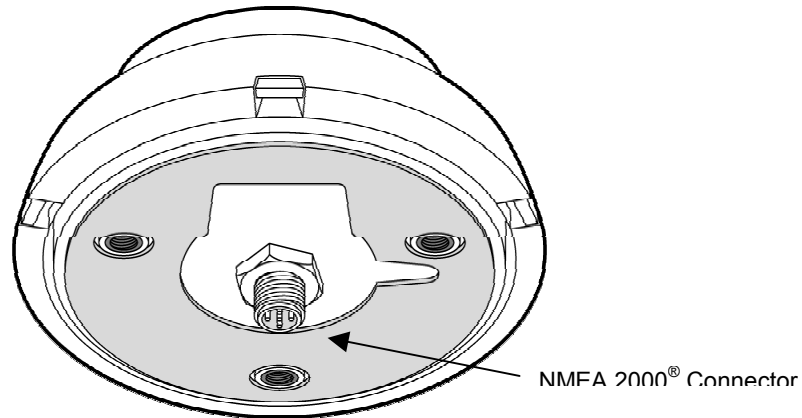

Figure 3 – GPS100 Interface Connector

The NMEA 2000[®] connector is a five pin male connector (see Figure 4). You connect the GPS100 to an NMEA 2000[®] network using a Maretron NMEA 2000[®] cable (or compatible cable) by connecting the female end of the cable to the GPS100 (note the key on the male connector and keyway on the female connector). Be sure the cable is connected securely and that the collar on the cable connector is tightened firmly. Connect the other end of the cable (male) to the NMEA 2000[®] network in the same manner. The GPS100 is designed such that you can plug or unplug it from an NMEA 2000[®] network while the power to the network is connected or disconnected. Please follow recommended practices for installing NMEA 2000[®] network products.

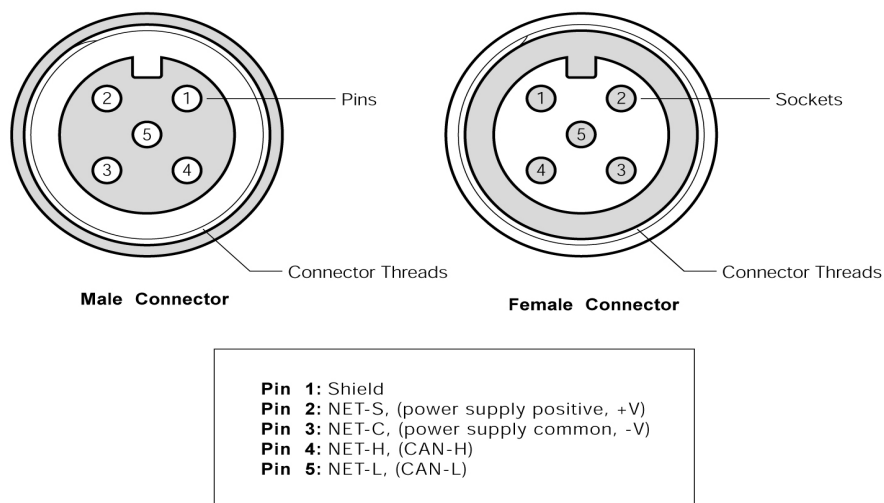

Figure 4 – NMEA 2000[®] Connector Face Views

2.4.1 Checking Connections

Once the NMEA 2000® connection to the Maretron GPS100 has been completed, check to see that heading information is being properly transmitted by observing an appropriate display. Refer to Section 5, “Troubleshooting”, if no heading information appears.

3 Operation

As shipped from the factory, the GPS100 automatically provides position, time, SOG, COG, magnetic variation, and satellite information and requires no user configuration. However, some of the GPS100 parameters are user configurable as described below:

- Desired Operating Mode – the GPS100 may be programmed to operate in 2D mode, 3D mode, or the best available operating mode (factory default)
- SBAS (WAAS) – the GPS100 may be programmed to use SBAS (WAAS) using the best available SBAS satellite (factory default). A specific SBAS satellite may be specified, or SBAS may be disabled altogether.
- SV Elevation Mask – as shipped from the factory, the GPS100 uses all visible satellites in its position solution, regardless of the elevation (angle above the horizon). A user may specify a SV Elevation Mask, such that only satellites with an elevation greater than this value will be used in the position solution.
- PDOP Mask – as shipped from the factory, the GPS100 will report a GPS fix whenever possible, regardless of the value of position dilution of precision (PDOP). A user may specify a PDOP Mask, such that whenever the PDOP is above the specified value, the GPS100 will report that no GPS fix is available.
- SNR Mask – As shipped from the factory, the GPS100 will use all detectable satellites in its position solution, regardless of the signal-to-noise ratio (SNR). A user may specify a SNR mask, such that only satellites with an SNR greater than this value will be used in the position solution.
- Antenna Altitude – A user may specify an antenna altitude for use when the GPS100 is operating in 2D mode. As shipped from the factory, the GPS100 will use the altitude calculated when it was last operating in 3D mode.
- Periodic Rate of Transmission – As shipped from the factory, the GPS100 transmits PGNs at a periodic rate. Alternatively, a PGN can be disabled by programming its periodic rate to zero.

These parameters may be configured using a Maretron instrumentation display, such as the Maretron DSM200, or other NMEA 2000® chartplotters or instrumentation displays with GPS configuration capability. Please refer to your chartplotter/display manual for details.

Users with direct access to the NMEA 2000® interface may configure these parameters directly through the NMEA 2000® interface. Please refer to Appendix A for a description of the NMEA 2000® messages used to configure these parameters.

3.1 Magnetic Variation

Magnetic variation is the angular difference between the true meridian (great circle connecting the geographic poles) and the magnetic meridian (direction of the lines of magnetic flux).

Magnetic variation has different values at different locations on the earth with most areas undergoing change to the magnetic variation over time.

The GPS100 indicates magnetic variation anywhere on Earth using the World Magnetic Model (WMM2005). It is important to understand that the WMM2005 geomagnetic model only characterizes that portion of the Earth's magnetic field that is generated in the Earth's fluid outer core (the main magnetic field). The portions of the geomagnetic field generated by the Earth's crust and upper mantle, and by the ionosphere and magnetosphere, are not represented in the WMM2005. Consequently, a magnetic sensor such as a compass or magnetometer may observe spatial and temporal magnetic anomalies when referenced to the WMM2005. In particular, certain local, regional, and temporal magnetic declination anomalies can exceed 10 degrees. Anomalies of this magnitude are not common but they do exist. Declination anomalies of the order of 3 or 4 degrees are not uncommon but are of small spatial extent and are relatively isolated.

On land, spatial anomalies are produced by mountain ranges, ore deposits, ground struck by lightning, geological faults, and cultural features such as trains, planes, tanks, railroad tracks, power lines, etc. The corresponding deviations are usually smaller at sea, and decrease with increasing altitude of an aircraft or spacecraft. In ocean areas, these anomalies occur most frequently along continental margins, near seamounts, and near ocean ridges, trenches, and fault zones, particularly those of volcanic origin. Ships and submarines are also sources of magnetic anomalies in the ocean.

However, from a global main field perspective, the declination (D), inclination (I), and grid variation (GV) RMS errors of WMM2005 are estimated to be less than 1.0° at the Earth's surface over the entire 5-year life span of the model. Also, the RMS errors at the Earth's surface horizontal intensity (H), the vertical component (Z), and the total intensity (F) of WMM2005 are estimated to be well below 200 nT over the entire 5-year life of the model. Thus, the WMM2005 meets and exceeds the accuracy requirements detailed in MIL-W-89500 (Defense Mapping Agency, 1993) for the entire life span of the model. To learn more about the WMM2005, please visit <http://www.ngdc.noaa.gov/seg/WMM/DoDWMM.shtml>.

4 Maintenance

Regular maintenance is important to ensure continued proper operation of the Maretron GPS100. Perform the following tasks periodically:

- Clean the unit with a soft cloth. Do not use chemical cleaners as they may remove paint or markings or may corrode the GPS100 enclosure or seals.
- Ensure that the unit is mounted securely and cannot be moved relative to the mounting surface. If the unit is loose, tighten the mounting screws.
- Check the security of the cable connected to the NMEA 2000® interface and tighten if necessary.

5 Troubleshooting

If you notice unexpected operation of the Maretron GPS100, follow the troubleshooting procedures in this section to remedy simple problems.

Symptom	Troubleshooting Procedure
No data output	<p>Check the connections to the NMEA 2000® connector and tighten if necessary</p> <p>Ensure that power is supplied to the connected NMEA 2000® cable</p> <p>Ensure that the GPS100 has a clear view to the horizon in all directions</p> <p>Ensure that no VHF, satellite, or radar antennas have been mounted near the GPS100</p>

If these steps do not solve your problem, please contact Maretron Technical Support (refer to Section 7 for contact information).

Warning: There are no user-serviceable components inside the Maretron GPS100. Opening the GPS100 will expose the sensitive electronic components to adverse environmental conditions that may render the unit inoperative. Please do not open the GPS100, as this will automatically void the warranty. If service is required, please return the unit to an authorized Maretron service location.

6 Technical Specifications

Specifications

Parameter	Value	Comment
Position Accuracy (Autonomous)	<10m	2D RMS (95% of Data Falls Within 10m)
Position Accuracy (WAAS)	< 3m	2D RMS (95% of Data Falls Within 3m)
Channels	12	Simultaneous Tracking of 12 Satellites
Position Update Rate	10 per Second	
Speed Update Rate	4 per Second	
Time Update Rate	1 per Second	
Hot Start	8 Seconds	Start Within Hours of Last Power Down
Warm Start	38 Seconds	Start Within Days of Last Power Down
Cold Start	45 Seconds	Start from Unknown Position
Satellite Based Augmentation System	WAAS	North America
	EGNOS	Europe
	MSAS	Asia
Battery Backup	Lithium (4-5 Days)	Holds Position for Hot/Warm Starts

GPS100 User's Manual

Certifications

Parameter	Comment
NMEA 2000	Level A
Maritime Navigation and Radiocommunication Equipment & Systems	Tested to IEC 60945
FCC and CE Mark	Electromagnetic Compatibility

NMEA 2000® Parameter Group Numbers (PGNs) - See Appendix A for Details

Description	PGN #	PGN Name	Default Rate
Periodic Data PGNs	126992	System Time	1 Time/Second
	128259	Speed	Disabled
	129025	Position, Rapid Update	10 Times/Second
	129026	COG and SOG, Rapid Update	4 Times/Second
	129029	GNSS Position Data	1 Time/Second
	129539	GNSS DOPs	1 Time/Second
	129540	GNSS Satellites in View	1 Time/Second
	127258	Magnetic Variation	1 Time/Second
Response to Requested PGNs	126464	PGN List (Transmit and Receive)	N/A
	126996	Product Information	N/A
	126998	Configuration Information	N/A
	129538	GNSS Control Status	N/A
	129541	GPS Almanac Data	N/A
Protocol PGNs	059392	ISO Acknowledge	N/A
	059904	ISO Request	N/A
	060416	ISO Transport Protocol, Connection Management	N/A
	060160	ISO Transport Protocol, Data Transfer	N/A
	060928	ISO Address Claim	N/A
	065240	ISO Address Command	N/A
	126206	NMEA	N/A

Electrical

Parameter	Value	Comment
Operating Voltage	9 to 16 Volts	DC Voltage
Power Consumption	<150mA	Average Current Drain
Load Equivalence Number (LEN)	3	NMEA 2000® Spec. (1LEN = 50 mA)
Reverse Battery Protection	Yes	Indefinitely
Load Dump Protection	Yes	Energy Rated per SAE J1113

Mechanical

Parameter	Value	Comment
Size	4" Diameter x 1.65" Tall	Not Including Antenna Mount Base
Weight	6 oz.	Not Including Antenna Mount Base
Mounting	Deck or Pole	

Environmental

Parameter	Value
IEC 60954 Classification	Exposed
Degree of Protection	IP67
Operating Temperature	-25°C to 55°C
Storage Temperature	-40°C to 70°C
Relative Humidity	93%RH @40° per IEC60945-8.2
Vibration	2-13.2Hz @ ±1mm, 13.2-100Hz @ 7m/s2 per IEC 60945-8.7
Rain and Spray	12.5mm Nozzle @ 100liters/min from 3m for 30min per IEC 60945-8.8
Solar Radiation	Ultraviolet B, A, Visible, and Infrared per IEC 60945-8.10
Corrosion (Salt Mist)	4 times 7days @ 40°C, 95%RH after 2 hour Salt Spray Per IEC 60945-8.12
Electromagnet Emission	Conducted and Radiated Emission per IEC 60945-9
Electromagnetic Immunity	Conducted, Radiated, Supply, and ESD per IEC 60945-10
Safety Precautions	Dangerous Voltage, Electromagnetic Radio Frequency per IEC 60945-12

7 Technical Support

If you require technical support for Maretron products, you can reach us in one of the following ways:

Telephone: 1-866-550-9100
Fax: 1-602-861-1777
E-mail: support@maretron.com
World Wide Web: <http://www.maretron.com>
Mail: Maretron, LLC
Attn: Technical Support
9034 N. 23rd Ave Suite 13
Phoenix, AZ 85021 USA

8 Installation Template

Please check the dimensions before using the following diagram as a template for drilling the mounting holes because the printing process may have distorted the dimensions.

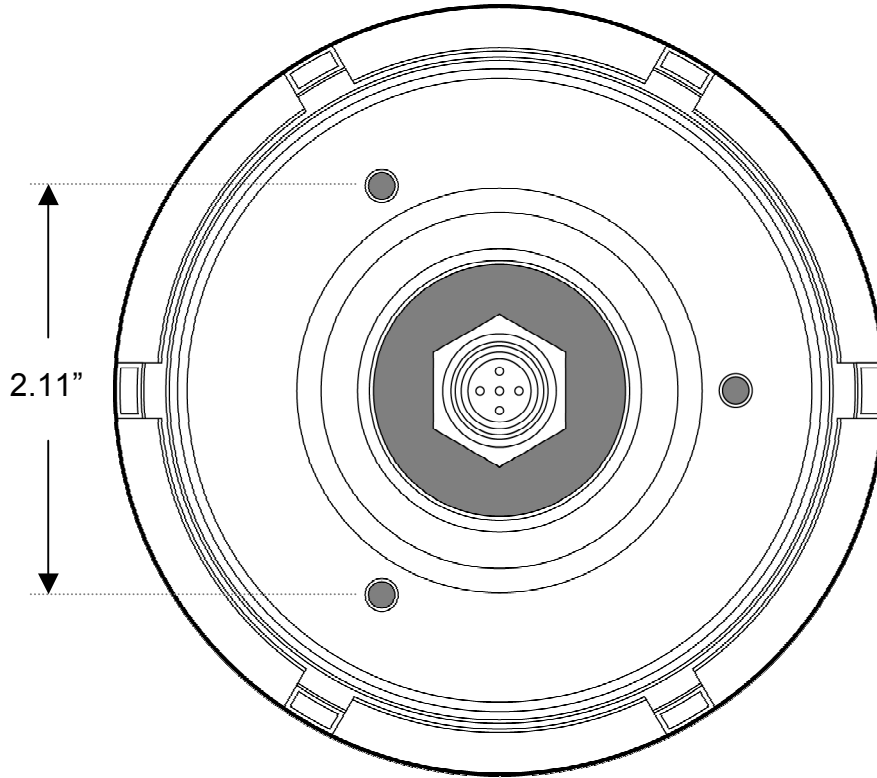

Figure 5 – Horizontal Mounting Surface Template

9 Maretron (2 Year) Limited Warranty

Maretron warrants the GPS100 to be free from defects in materials and workmanship for **two (2) years** from the date of original purchase. If within the applicable period any such products shall be proved to Maretron's satisfaction to fail to meet the above limited warranty, such products shall be repaired or replaced at Maretron's option. Purchaser's exclusive remedy and Maretron's sole obligation hereunder, provided product is returned pursuant to the return requirements below, shall be limited to the repair or replacement, at Maretron's option, of any product not meeting the above limited warranty and which is returned to Maretron; or if Maretron is unable to deliver a replacement that is free from defects in materials or workmanship, Purchaser's payment for such product will be refunded. Maretron assumes no liability whatsoever for expenses of removing any defective product or part or for installing the repaired product or part or a replacement therefore or for any loss or damage to equipment in connection with which Maretron's products or parts shall be used. With respect to products not manufactured by Maretron, Maretron's warranty obligation shall in all respects conform to and be limited to the warranty actually extended to Maretron by its supplier. The foregoing warranties shall not apply with respect to products subjected to negligence, misuse, misapplication, accident, damages by circumstances beyond Maretron's control, to improper installation, operation, maintenance, or storage, or to other than normal use or service.

THE FOREGOING WARRANTIES ARE EXPRESSLY IN LIEU OF AND EXCLUDES ALL OTHER EXPRESS OR IMPLIED WARRANTIES, INCLUDING BUT NOT LIMITED TO THE IMPLIED WARRANTIES OF MERCHANTABILITY AND OF FITNESS FOR A PARTICULAR PURPOSE.

Statements made by any person, including representatives of Maretron, which are inconsistent or in conflict with the terms of this Limited Warranty, shall not be binding upon Maretron unless reduced to writing and approved by an officer of Maretron.

IN NO CASE WILL MARETRON BE LIABLE FOR INCIDENTAL OR CONSEQUENTIAL DAMAGES, DAMAGES FOR LOSS OF USE, LOSS OF ANTICIPATED PROFITS OR SAVINGS, OR ANY OTHER LOSS INCURRED BECAUSE OF INTERRUPTION OF SERVICE. IN NO EVENT SHALL MARETRON'S AGGREGATE LIABILITY EXCEED THE PURCHASE PRICE OF THE PRODUCT(S) INVOLVED. MARETRON SHALL NOT BE SUBJECT TO ANY OTHER OBLIGATIONS OR LIABILITIES, WHETHER ARISING OUT OF BREACH OF CONTRACT OR WARRANTY, TORT (INCLUDING NEGLIGENCE), OR OTHER THEORIES OF LAW WITH RESPECT TO PRODUCTS SOLD OR SERVICES RENDERED BY MARETRON, OR ANY UNDERTAKINGS, ACTS OR OMISSIONS RELATING THERETO.

Maretron does not warrant that the functions contained in any software programs or products will meet purchaser's requirements or that the operation of the software programs or products will be uninterrupted or error free. Purchaser assumes responsibility for the selection of the software programs or products to achieve the intended results, and for the installation, use and results obtained from said programs or products. No specifications, samples, descriptions, or illustrations provided Maretron to Purchaser, whether directly, in trade literature, brochures or other documentation shall be construed as warranties of any kind, and any failure to conform with such specifications, samples, descriptions, or illustrations shall not constitute any breach of Maretron's limited warranty.

Warranty Return Procedure:

To apply for warranty claims, contact Maretron or one of its dealers to describe the problem and determine the appropriate course of action. If a return is necessary, place the product in its original packaging together with proof of purchase and send to an Authorized Maretron Service Location. You are responsible for all shipping and insurance charges. Maretron will return the replaced or repaired product with all shipping and handling prepaid except for requests requiring expedited shipping (i.e. overnight shipments). Failure to follow this warranty return procedure could result in the product's warranty becoming null and void.

Maretron reserves the right to modify or replace, at its sole discretion, without prior notification, the warranty listed above. To obtain a copy of the then current warranty policy, please go to the following web page:

<http://www.maretron.com/company/warranty.php>

This Page Intentionally Left Blank

Appendix A – NMEA 2000® Interfacing

GPS100 NMEA 2000® Periodic Data Transmitted PGNs

PGN 126992 – System Time

The GPS100 uses this PGN to provide a regular transmission of UTC time and date and to provide synchronism for measurement data. The factory default for periodic transmission rate is once per second. The transmission of this PGN can be disabled (see PGN 126208 – NMEA Request Group Function – Transmission Periodic Rate).

- Field 1: SID – The sequence identifier field is used to tie related PGNs together. For example, the GPS100 will transmit identical SIDs for 126992 (System Time), 128259 (Speed), 129026 (COG and SOG, Rapid Update), 129029 (GNSS Position Data), 129539 (GNSS DOPs), and 129540 (GNSS Satellites in View) to indicate that the readings are linked together (i.e., the data from each PGN was taken at the same time although they are reported at slightly different times).
- 2: Source – This field is used to indicate the type of time source, therefore this field always reads as 0 (GPS).
- 3: Reserved (4 bits) – This field is reserved by NMEA; therefore, this field always contains a value of 0xF (the GPS100 sets all reserved bits to a logic 1)
- 4: Date – This field is used to indicate the UTC Date in resolution of 1 day (the number of days since January 1, 1970).
- 5: Time – This field is used to indicate the UTC Time in resolution of 1×10^{-4} s (24 hour clock, 0.0000 = midnight).

PGN 127258 – Magnetic Variation

The GPS100 uses this PGN to provide a regular transmission of magnetic variation. The factory default for periodic transmission rate is once per second. The transmission of this PGN can be disabled (see PGN 126208 – NMEA Request Group Function – Transmission Periodic Rate).

- Field 1: SID – The sequence identifier field is used to tie related PGNs together. For example, the GPS100 will transmit identical SIDs for 126992 (System Time), 128259 (Speed), 129026 (COG and SOG, Rapid Update), 129029 (GNSS Position Data), 129539 (GNSS DOPs), and 129540 (GNSS Satellites in View) to indicate that the readings are linked together (i.e., the data from each PGN was taken at the same time although they are reported at slightly different times).
- 2: Variation Source – The GPS100 uses the WMM2005 for variation, therefore this field always reads as 5 (WMM2005).
- 3: Reserved (4 bits) – This field is reserved by NMEA; therefore, this field always contains a value of 0xF (the GPS100 sets all reserved bits to a logic 1)
- 4: Age of Service (Date) – This field is used to indicate the UTC Date in resolution of 1 day (the number of days since January 1, 1970).
- 5: Variation – This field is used to indicate the magnetic variation where positive values represent Easterly and negative values represent Westerly variation.

PGN 128259 – Speed

The GPS100 uses this PGN to provide a regular transmission that describes the motion of a vessel. The factory default for periodic transmission rate is disabled. The PGN can be

transmitted at a periodic rate of once per second (see PGN 126208 – NMEA Request Group Function – Transmission Periodic Rate).

- Field 1: SID – The sequence identifier field is used to tie related PGNs together. For example, the GPS100 will transmit identical SIDs for 126992 (System Time), 128259 (Speed), 129026 (COG and SOG, Rapid Update), 129029 (GNSS Position Data), 129539 (GNSS DOPs), and 129540 (GNSS Satellites in View) to indicate that the readings are linked together (i.e., the data from each PGN was taken at the same time although they are reported at slightly different times).
- 2: Speed Water Referenced – Since the GPS100 does not provide this data, this field always reads as 0xFFFF (data not available).
 - 3: Speed Ground Referenced – This field is used to indicate the speed over ground (SOG) in resolution of 1×10^{-2} m/s.
 - 4: Reserved (24 bits) – This field is reserved by NMEA; therefore, this field always contains a value of 0xFFFFFFFF (the GPS100 sets all reserved bits to a logic 1)

PGN 129025 – Position, Rapid Update

The GPS100 uses this PGN to provide latitude and longitude referenced to WGS84. The factory default for periodic transmission rate is 10 times per second. The transmission of this PGN can be disabled (see PGN 126208 – NMEA Request Group Function – Transmission Periodic Rate).

- Field 1: Latitude – Latitude in 1×10^{-7} degrees ("-" = south, "+" = north)
2: Longitude – Longitude in 1×10^{-7} degrees ("-" = west, "+" = east)

PGN 129026 – COG and SOG, Rapid Update

The GPS100 uses this PGN to provide Course Over Ground (COG) and Speed Over Ground (SOG). The factory default for periodic transmission rate is four times per second. The transmission of this PGN can be disabled (see PGN 126208 – NMEA Request Group Function – Transmission Periodic Rate).

- Field 1: SID – The sequence identifier field is used to tie related PGNs together. For example, the GPS100 will transmit identical SIDs for 126992 (System Time), 128259 (Speed), 129026 (COG and SOG, Rapid Update), 129029 (GNSS Position Data), 129539 (GNSS DOPs), and 129540 (GNSS Satellites in View) to indicate that the readings are linked together (i.e., the data from each PGN was taken at the same time although they are reported at slightly different times).
- 2: COG Reference – This field is used to indicate the direction reference of the course over ground. This field always reads as 0 (True, not magnetic).
 - 3: Reserved (6 bits) – This field is reserved by NMEA; therefore, this field always contains a value of 0x3F (the GPS100 sets all reserved bits to a logic 1)
 - 4: Course Over Ground – This field is used to indicate the course over ground (COG) in resolution of 1×10^{-4} radians.
 - 5: Speed Over Ground – This field is used to indicate the speed over ground (SOG) in resolution of 1×10^{-2} m/s.
 - 6: Reserved (16 bits) – This field is reserved by NMEA; therefore, this field always contains a value of 0xFFFF (the GPS100 sets all reserved bits to a logic 1)

PGN 129029 – GNSS Position Data

The GPS100 uses this PGN to convey a comprehensive set of Global Navigation Satellite System (GNSS) parameters, including position information. The factory default for periodic transmission rate is once per second. The transmission of this PGN can be disabled (see PGN 126208 – NMEA Request Group Function – Transmission Periodic Rate).

- Field 1: SID – The sequence identifier field is used to tie related PGNs together. For example, the GPS100 will transmit identical SIDs for 126992 (System Time), 128259 (Speed), 129026 (COG and SOG, Rapid Update), 129029 (GNSS Position Data), 129539 (GNSS DOPs), and 129540 (GNSS Satellites in View) to indicate that the readings are linked together (i.e., the data from each PGN was taken at the same time although they are reported at slightly different times).
- 2: Position date –UTC Date in resolution of 1 day (The number of days since January 1, 1970).
 - 3: Position time – UTC Time in resolution of 1×10^{-4} s (24 hour clock, 0.0000 = midnight).
 - 4: Latitude – Latitude in 1×10^{-16} degrees ("-" = south, "+" = north)
 - 5: Longitude – Longitude in 1×10^{-16} degrees ("-" = west, "+" = east)
 - 6: Altitude – Altitude referenced to WGS-84 in (resolution of 1×10^{-6} m)
 - 7: Type of System – This field is used to indicate type of GPS system. The GPS100 will show either 0 (GPS) or 3 (GPS+SBAS, factory default) dependent on whether the user has enabled SBAS.
 - 8: Method, GNSS – This field is used to indicate the quality of GNSS information. The GPS100 indicates one of the following values: 0=no GPS, 1=GNSS fix, 2=DGNSS fix, 6=Estimated (dead reckoning).
 - 9: Integrity – This field always contains a value of 0 (no integrity checking).
 - 10: Reserved (6 bits) – This field is reserved by NMEA; therefore, this field always contains a value of 0x3F (the GPS100 sets all reserved bits to a logic 1)
 - 11: Number of SVs – This field is used to indicate the number of satellites used in solution.
 - 12: HDOP – This field is used to indicate the horizontal dilution of precision with a resolution of 1×10^{-2} (unitless).
 - 13: PDOP – This field is used to indicate the positional dilution of precision with a resolution of 1×10^{-2} (unitless).
 - 14: Geoidal Separation – This field is used to indicate the Geoidal Separation in resolution of 1×10^{-2} m.
 - 15: Number of Reference Stations – This field always contains a value of 0
 - 16: Reference Station Type "1" – This field always contains a value of 0xF (Null)
 - 17: Reference Station ID "1" – This field always contains a value of 0xFFFF (data not available)
 - 18: Age of DGNSS Corrections "1" – This field always contains a value of 0xFFFF (data not available)

PGN 129539 – GNSS DOPs

The GPS100 uses this PGN to provide a single transmission containing GNSS status and dilution of precision components (DOP) that indicate the contribution of satellite geometry to the overall positioning error. There are three DOP parameters reported, horizontal (HDOP), Vertical (VDOP) and time (TDOP). The factory default for periodic transmission rate is once

per second. The transmission of this PGN can be disabled (see PGN 126208 – NMEA Request Group Function – Transmission Periodic Rate).

- Field 1: SID – The sequence identifier field is used to tie related PGNs together. For example, the GPS100 will transmit identical SIDs for 126992 (System Time), 128259 (Speed), 129026 (COG and SOG, Rapid Update), 129029 (GNSS Position Data), 129539 (GNSS DOPs), and 129540 (GNSS Satellites in View) to indicate that the readings are linked together (i.e., the data from each PGN was taken at the same time although they are reported at slightly different times).
- 2: Set Mode – This field is used to indicate the desired mode of operation: 0 = 1D, 1 = 2D, 2 = 3D, 3 = Auto (factory default), 4-5 = Reserved, 6 = Error, 7 = Null.
- 3: Op Mode – This field is used to indicate the actual current mode of operation: 0 = 1D, 1 = 2D, 2 = 3D, 3 = Auto (factory default), 4-5 = Reserved, 6 = Error, 7 = Null.
- 4: Reserved (2 bits) – This field is reserved by NMEA; therefore, this field always contains a value of 0x3 (the GPS100 sets all reserved bits to a logic 1)
- 5: HDOP – This field is used to indicate the horizontal dilution of precision with a resolution of 1×10^{-2} (unitless).
- 6: VDOP – This field is used to indicate the vertical dilution of precision with a resolution of 1×10^{-2} (unitless).
- 7: TDOP – This field is used to indicate the time dilution of precision with a resolution of 1×10^{-2} (unitless).

PGN 129540 – GNSS Satellites in View

The GPS100 uses this PGN to provide the GNSS information on current satellites in view tagged by sequence ID. Information includes PRN, elevation, azimuth, and SNR. Field 4 defines the number of satellites. Fields 5 through 11 defines the satellite number and the information. Fields 5 through 11 are sequentially repeated for each satellite to be transmitted. The factory default for periodic transmission rate is once per second. The transmission of this PGN can be disabled (see PGN 126208 – NMEA Request Group Function – Transmission Periodic Rate).

- Field 1: SID – The sequence identifier field is used to tie related PGNs together. For example, the GPS100 will transmit identical SIDs for 126992 (System Time), 128259 (Speed), 129026 (COG and SOG, Rapid Update), 129029 (GNSS Position Data), 129539 (GNSS DOPs), and 129540 (GNSS Satellites in View) to indicate that the readings are linked together (i.e., the data from each PGN was taken at the same time although they are reported at slightly different times).
- 2: Mode – This field always reads as 3 (Null), indicating that range residuals are used to calculate position, and not calculated after the position.
- 3: Reserved (6 bits) – This field is reserved by NMEA; therefore, this field always contains a value of 0x3F (the GPS100 sets all bits to a logic 1)
- 4: Number of SVs – This field is used to indicate the number of current satellites in view. Fields 5-11 are repeated the number of times specified by this field's value.
- 5: PRN "1" – This field is used to indicate the Satellite ID Number of the satellite (1-32=GPS, 33-64=SBAS, 65-96=GLONASS).
- 6: Elevation "1" – This field is used to indicate the Elevation of the satellite.
- 7: Azimuth "1" – This field is used to indicate the Azimuth of the satellite.
- 8: SNR "1" – This field is used to indicate the Signal to Noise Ratio (SNR) of the satellite.

- 9: Range Residuals "1" – The GPS100 always sets this field to a value of 0x7FFFFFFF (data not available)
- 10: PRN Status "1" – This field is used to indicate the status of the first satellite in the list. (0=Not Tracked, 1=Tracked but not used in solution, 2=Used in solution without Differential corrections, 3=Differential Corrections available, 4=Tracked with Differential Corrections, 5=used with Differential Corrections)
- 11: Reserved (4 bits) – This field is reserved by NMEA; therefore, this field always contains a value of 0xF (the GPS100 sets all bits to a logic 1)

If Field 4 contains a value greater than one, then the group of fields 5 through 11 is repeated until this group appears the number of times indicated by the value of Field 4.

GPS100 NMEA 2000® Non-Periodic Data Transmitted PGNs

PGN 129538 – GNSS Control Status

The GPS100 uses this PGN to provide the GNSS common satellite receiver parameter status. GPS100 sends this PGN only when requested by PGN 059904 (ISO Request).

- Field 1: SV Elevation Mask – If the elevation of a satellite (angle above the horizon) is below this value, the GPS100 will not use that satellite in the solution. Units are 1×10^{-4} radians. The factory default for this value is 0.1309 radians, which corresponds to 7.5° .
- 2: PDOP Mask – If the PDOP exceeds this value, the GPS100 will indicate "No GNSS fix" or "Dead Reckoning Mode" in PGN 129029. Units are 1×10^{-2} (unitless). The factory default is to report a fix whenever possible, regardless of PDOP.
 - 3: PDOP Switch – If the PDOP exceeds this value, a GPS receiver will switch from 3D to 2D mode. For the GPS100, this field always contains a value of 0x7FFF, indicating that the GPS100 will always attempt to operate in 3D mode. Units are 1×10^{-2} (unitless). The factory default is to report a fix whenever possible, regardless of PDOP.
 - 4: SNR Mask – If the SNR of a satellite is below this value, the GPS100 will not use that satellite in the solution. Units are 1×10^{-2} dB. The factory default is to use all available satellites. The factory default setting for the SNR Mask is 28 dB.
 - 5: GNSS Mode – This field is used to indicate the desired mode of operation: 0 = 1D, 1 = 2D, 2 = 3D, 3 = Auto (factory default), 4-5 = Reserved, 6 = Error, 7 = Null.
 - 6: DGNSS Mode – This field is used to indicate the desired mode of operation of DGNSS (0=do not use SBAS, 1 and 3=Use SBAS when available). The factory default value for this field is 1 (use SBAS when available).
 - 7: Position / Velocity Filter – This field always contains a value of 0x3, indicating that the GPS100 does not allow configuration of the position / velocity filter.
 - 8: Max Correction Age – This field always contains a value of 0xFFFF, indicating that the GPS100 does not allow configuration of the maximum age of SBAS correction data to be used.
 - 9: Antenna Altitude for 2D Mode – This field is used to indicate the antenna altitude for the GPS100 to use when operating in 2D mode in units of 1×10^{-2} m. The factory default for this field is 0.0 m.
 - 10: Use Antenna Altitude for 2D Mode – This field is used to indicate whether the GPS100 will use Antenna Altitude (Field 9) when operating in 2D mode. The factory

default for this field is 0 (do not use the antenna altitude; rather, use the altitude calculated when the GPS100 was most recently in 3D mode).

PGN 129541 – GPS Almanac Data

The GPS100 uses this PGN to provide a single transmission that contains relevant almanac data for the GPS. The almanac contains satellite vehicle course orbital parameters. This information is not considered precise and is only valid for several months at a time. GPS100 receive almanac data directly from the satellites. GPS100 sends this PGN only when requested by PGN 059904 (ISO Request).

- Field 1: PRN – PRN of the satellite for which almanac data is being provided.
2: GPS Week Number – The number of weeks since Jan 6, 1980.
3: SV Health Bits – Bits 17-24 of each almanac page. Refer to ICD-GPS-200 paragraph 20.3.3.5.1.3, Table 20-VII and Table 20-VIII.
4: Eccentricity – Reference ICD-GPS-200 Table 20-VI.
5: Almanac Reference Time – Reference ICD-GPS-200 Table 20-VI.
6: Inclination Angle – Reference ICD-GPS-200 Table 20-VI.
7: Rate of Right Ascension – The OMEGADOT parameter. Reference ICD-GPS-200 Table 20-VI.
8: Root of Semi-major Axis – Reference ICD-GPS-200 Table 20-VI.
9: Argument of Perigee – Reference ICD-GPS-200 Table 20-VI.
10: Longitude of Ascension Mode – Reference ICD-GPS-200 Table 20-VI.
11: Mean Anomaly – Reference ICD-GPS-200 Table 20-VI.
12: Clock Parameter 1 – Reference ICD-GPS-200 Table 20-VI.
13: Clock Parameter 2 – Reference ICD-GPS-200 Table 20-VI.
14: Reserved (2 bits) – This field is reserved by NMEA; therefore, this field always contains a value of 0x3 (the GPS100 sets all bits to a logic 1)

GPS100 NMEA 2000® Received PGNs

PGN 126208 – NMEA Command Group Function – GNSS Control Status

This will change the configuration of the GPS100.

- Field 1: Complex Command Group Function Code (8 bits) – set this field's value to 0x01, which denotes a command PGN.
2: Commanded PGN (24 bits) – set this field's value to 129538, which denotes the GNSS Control Status PGN.
3: Priority Setting (4 bits) – set this field's value to 0x8, which indicates to leave priority settings unchanged.
4: Reserved (4 bits) – set this field's value to 0xF, which is the value for a reserved field of this size.
5: Number of Pairs of Commanded Parameters to Follow (8 bits) – set this field's value to the number of configurations to be changed.
6: Field number of first commanded parameter (8 bits). Please refer to the table below for valid values for this field.
7: Value of first command parameter (size depends on the field number specified in field 6 of this PGN) – please refer to the description of PGN 129538 above for details.

Field Number of Commanded Parameter	Name of Commanded Parameter	Size (Bytes)
1	SV Elevation Mask	2
2	PDOP Mask	2
4	SNR Mask	2
5	GNSS Mode	1
6	DGNSS Mode	1
9	Antenna Altitude	4
10	Use Antenna Altitude	1

Fields 6 and 7 are repeated pair wise until all parameters to be modified have been specified.

PGN 126208 – NMEA Command Group Function – Maretron Proprietary Restart GPS Engine

This will force the GPS100 to restart its GPS engine without performing a full reset of the unit.

- Field 1: Complex Command Group Function Code (8 bits) – set this field's value to 0x01, which denotes a command PGN
- 2: Commanded PGN (24 bits) – set this field's value to 126720, which denotes the Maretron proprietary PGN
- 3: Priority Setting (4 bits) – set this field's value to 0x8, which indicates to leave priority settings unchanged
- 4: Reserved (4 bits) – set this field's value to 0xF, which is the value for a reserved field of this size
- 5: Number of Pairs of Commanded Parameters to Follow (8 bits) – set this field's value to 0x4, indicating that four parameters will follow
- 6: Number of First Commanded Parameter (8 bits) – set this field's value to 0x1
- 7: Maretron Vendor ID and Industry Code (16 bits) – set this field's value to 0x9889
- 8: Number of Second Commanded Parameter (8 bits) – set this field's value to 0x02
- 9: Product Code (16 bits) – set this field's value to 0x6F0, which is the NMEA 2000® product code for the GPS100.
- 10: Number of Third Commanded Parameter (8 bits) – set this field's value to 0x03
- 11: Software Code (16 bits) – set this field's value to 0x0001, which is the identifier for this version of the Maretron proprietary protocol
- 12: Maretron Command (8 bits) – set this field's value to 0x30, which will force the GPS Engine to restart as selected by the following field.
- 13: Restart mode (8 bits) – set this field's value to select the restart mode, 0=Factory restart, 1=Cold start.

PGN 126208 – NMEA Command Group Function – Maretron Proprietary SBAS Parameter

This PGN will configure usage of SBAS (WAAS) satellite data.

- Field 1: Complex Command Group Function Code (8 bits) – set this field's value to 0x01, which denotes a command PGN

- 2: Commanded PGN (24 bits) – set this field's value to 126720 decimal (0x1EF00 hexadecimal), which denotes the Maretron proprietary PGN
- 3: Priority Setting (4 bits) – set this field's value to 0x8, which indicates to leave priority settings unchanged
- 4: Reserved (4 bits) – set this field's value to 0xF, which is the value for a reserved field of this size
- 5: Number of Pairs of Commanded Parameters to Follow (8 bits) – set this field's value to 0x4, indicating that four parameters will follow
- 6: Number of First Commanded Parameter (8 bits) – set this field's value to 0x1
- 7: Maretron Vendor ID and Industry Code (16 bits) – set this field to 0x9889, which is a combination of Maretron's vendor ID and the marine industry code
- 8: Number of Second Commanded Parameter (8 bits) – set this field's value to 0x02
- 9: Product Code (16 bits) – set this field's value to 0x6F0, which is the NMEA 2000® product code for the GPS100.
- 10: Number of Third Commanded Parameter (8 bits) – set this field's value to 0x03
- 11: Software Code (16 bits) – set this field's value to 0x0001, which is the identifier for this version of the Maretron proprietary protocol
- 12: Maretron Command (8 bits) – set this field's value to 0x33, which will change the SBAS parameter as selected by the following fields.
- 13: SBAS parameter (24 bits) – this field includes 3 parameters:

23	16	15	8	7	0
Timeout		FlgBits		PRN	

Timeout: Maximum age in seconds (1-250) of differential corrections (factory default=18). A value of 0 will restore the timeout values to the factory default value.

FlgBits: Status of SBAS operation (default=0x00)

Bit 0: SBAS Timeout: 0 = default, 1 = user. If this field is set to 0, then the default value of 18 seconds is used. If this field is set to 1, then the value of the *Timeout* field is used.

Bit 1: Reserved. This field should always be programmed to 0.

Bit 2: Reserved. This field should always be programmed to 0.

Bit 3: SBAS PRN: 0 = AutoScan; 1 = Manual (user). If this field is set to 0, then the GPS100 will use the SBAS satellite with the strongest signal. If this field is set to 1, then the GPS100 will only use the SBAS satellite whose PRN is programmed into the *PRN* field.

Bit 4: Reserved. This field should always be programmed to 0.

PRN: This causes the GPS to use a particular SBAS satellite by specifying the PRN of the desired SBAS satellite if Bit 3 of *FlgBits* = 1. A programmed value of 0 for the PRN will force the GPS to auto scan (factory default) while programmed values of 120-138 use the SBAS satellite with the corresponding PRN.

PGN 126208 – NMEA Request Group Function – Transmission Periodic Rate

This PGN will enable or disable the periodic transmission of specific PGNs.

- Field 1: Complex Command Group Function Code (8 bits) – set this field's value to 0x00, which denotes a request PGN
- 2: Requested PGN (24 bits) – set this field's value to the corresponding PGN for which you wish to change the periodic rate.
- 3: Transmission Interval (32 bits) – set this field's value to 0x0 to disable the periodic transmission of the PGN identified in field 2 above. Otherwise, program in the default periodic rate to restore periodic transmission of the PGN identified in field 2 above. The resolution of this field is 1 millisecond.
- 4: Transmission Interval Offset (16 bits) – set this field's value to 0xFFFF; all other values will cause the request to be rejected.
- 5: Number of Pairs of Commanded Parameters to Follow (8 bits) – set this field's value to 0x0.