

# **MASTERVOLT**

USERS MANUAL / GEBRUIKERSHANDLEIDING  
BETRIEBSANLEITUNG / MANUEL UTILISATEUR  
MANUAL DE UTILIZACION / INSTRUZIONI PER L'USO

## **Mass GI** **3.5 / 7.0 / 7.0 MultiTap**

Isolation transformer



MASTERVOLT  
Snijdersbergweg 93,  
1105 AN Amsterdam  
The Netherlands  
Tel.: +31-20-3422100  
Fax.: +31-20-6971006  
www.Mastervolt.com

ENGLISH:	PAGE 1
NEDERLANDS:	PAGINA 25
DEUTSCH:	SEITE 49
FRANÇAIS:	PAGINA 73
CASTELLANO:	PÁGINA 97
ITALIANO:	PÁGINA 121

Copyright © 2009 Mastervolt, v 3.2 June 2009

# 1 OVERVIEW

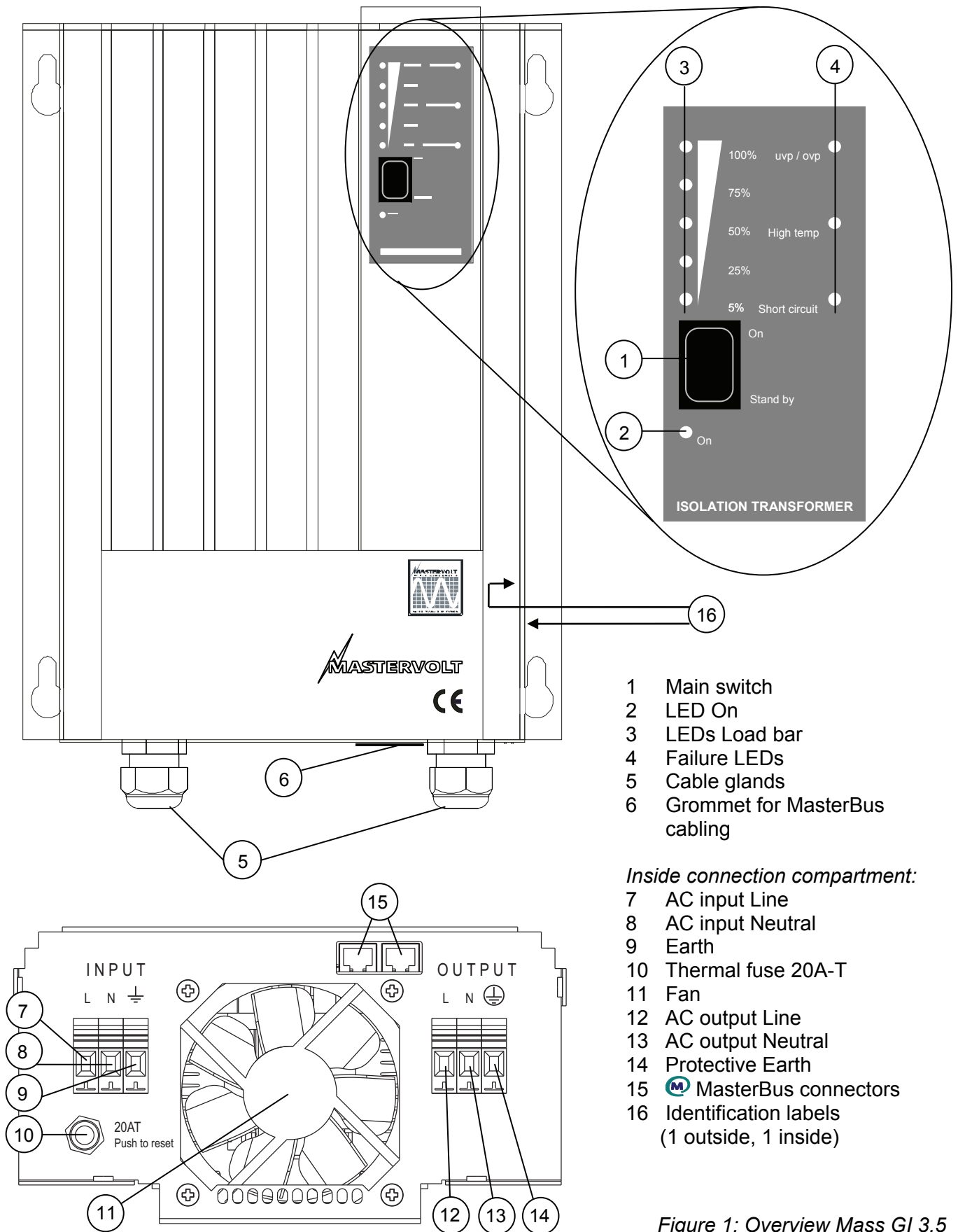

- 1 Main switch
- 2 LED On
- 3 LEDs Load bar
- 4 Failure LEDs
- 5 Cable glands
- 6 Grommet for MasterBus cabling

*Inside connection compartment:*



- 7 AC input Line
- 8 AC input Neutral
- 9 Earth
- 10 Thermal fuse 20A-T
- 11 Fan
- 12 AC output Line
- 13 AC output Neutral
- 14 Protective Earth
- 15  MasterBus connectors
- 16 Identification labels (1 outside, 1 inside)

Figure 1: Overview Mass GI 3.5



- 17 Fans
- 18  MasterBus connectors
- 19 Input terminal  
Earth  
AC input Neutral  
AC input Line
- 20 Output terminal  
Protective Earth  
AC output Neutral  
AC output Line

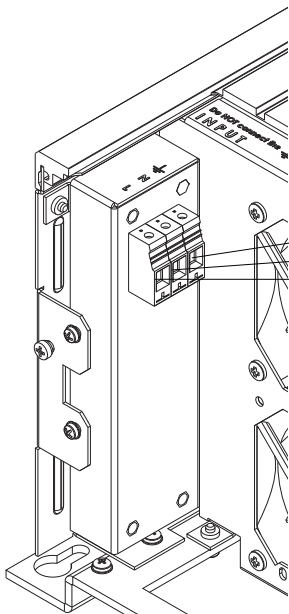
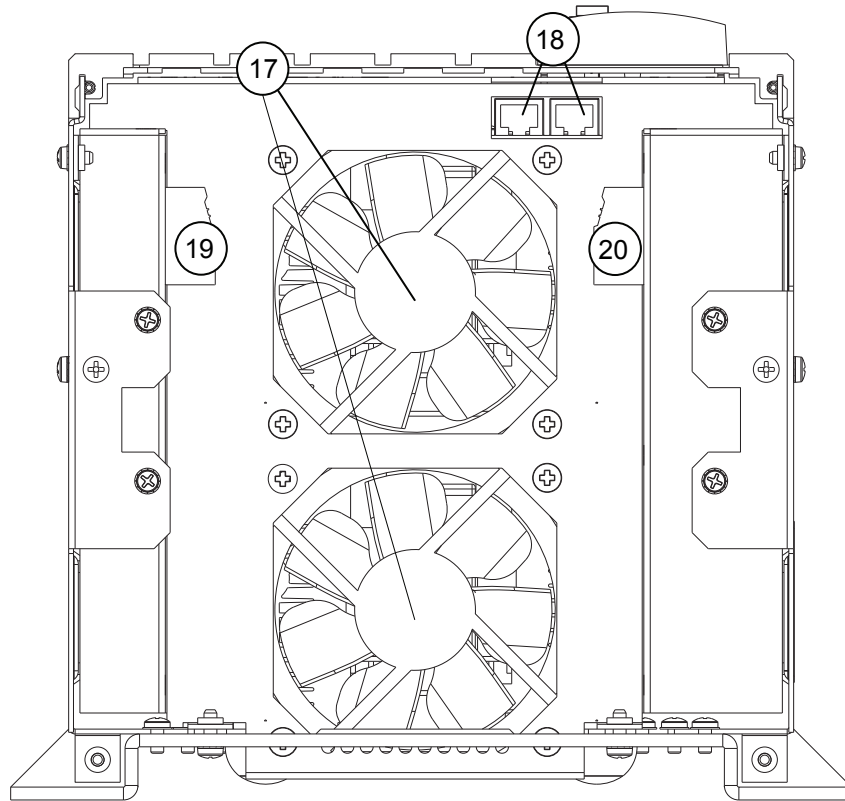

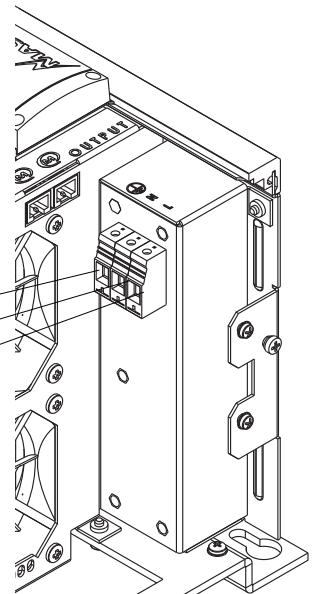
**WARNING**  
Never connect Earth (input)  
to Protective Earth (output)!

Figure 2: Overview Mass GI 7.0/ 7.0 MultiTap

## CONTENTS

v 3.2 June 2009

<b>1</b>	<b>OVERVIEW</b>	<b>2</b>
<b>2</b>	<b>GENERAL INFORMATION</b>	<b>6</b>
2.1	Product description .....	6
2.2	Use of this manual .....	6
2.3	Guarantee specifications .....	6
2.4	Validity of this manual .....	6
2.5	Quality .....	6
2.6	Liability .....	6
2.7	Identification label .....	6
2.8	Changes to the Mass GI .....	6
<b>3</b>	<b>SAFETY GUIDELINES AND MEASURES</b>	<b>7</b>
3.1	Warnings and symbols .....	7
3.2	Use for intended purpose .....	7
3.3	Organizational measures .....	7
3.4	Maintenance & repair .....	7
3.5	General safety and installation precautions .....	7
3.6	Warning regarding life support applications .....	7
<b>4</b>	<b>HOW IT WORKS</b>	<b>8</b>
4.1	MasterBus communication .....	8
4.2	Protection .....	8
4.2.1	Overload protection .....	8
4.2.2	Second overload protection .....	8
4.2.3	Peak current limitation .....	8
4.2.4	Short circuit protection .....	8
4.2.5	Thermal protection .....	8
4.2.6	MasterBus power supply protection .....	8
<b>5</b>	<b>OPERATION</b>	<b>9</b>
5.1	Resetting the Mass GI .....	9
5.2	Maintenance .....	9
5.3	LED indicators .....	9
<b>6</b>	<b>MASTERBUS</b>	<b>10</b>
6.1	What is MasterBus? .....	10
6.2	How to set up a MasterBus network .....	11
<b>7</b>	<b>MASTERBUS ON THE MASS GI</b>	<b>12</b>
7.1	Monitoring .....	12
7.2	Alarm .....	12
7.3	History .....	12
7.4	Configuration general .....	12
7.5	Reset settings .....	12
7.6	Event Configuration .....	13
7.7	Mass GI Event Source List .....	13
7.8	Mass GI Event Target List .....	13
<b>8</b>	<b>INSTALLATION STAND ALONE</b>	<b>14</b>
8.1	Unpacking .....	14
8.2	Before you start .....	14
8.3	Extra materials needed .....	14
8.4	Cable sizes .....	14
8.5	Choosing the location to install .....	14
8.6	Mounting of the cabinet to a wall .....	14

8.7	Opening the connection compartment.....	14
8.8	Cabling.....	15
8.9	Connection.....	15
8.10	Commissioning after installation.....	15
<b>9</b>	<b>TWO TO FOUR MASS GI'S IN PARALLEL (ADDITIONAL INFO)</b>	<b>16</b>
9.1	Installation of four Mass GI's in parallel (Mass GI 3.5 only).....	16
9.2	Parallel operation in one group.....	16
9.3	Multiple groups of (multiple) Mass GI(s) running in parallel.....	16
9.4	Safety devices in parallel configuration.....	17
<b>10</b>	<b>QUICK INSTALLATION</b>	<b>18</b>
<b>11</b>	<b>TROUBLE SHOOTING</b>	<b>19</b>
<b>12</b>	<b>TECHNICAL DATA</b>	<b>20</b>
12.1	Specifications.....	20
12.2	Dimensions.....	21
<b>13</b>	<b>EC DECLARATION OF CONFORMITY</b>	<b>23</b>

## 2 GENERAL INFORMATION

### 2.1 Product description

The Mass GI is an isolation transformer, based on switch mode technology, providing you with a separation between AC shore-power and the onboard AC electrical system. This prevents corrosion of your metal ship while grounding is still present.

The input circuit of the Mass GI is equipped with a soft start circuit to eliminate high inrush currents, and an automatic circuit breaker (Mass GI 3.5) or internal fuse (Mass GI 7.0) to protect your system against electrical overload.

### 2.2 Use of this manual

Copyright © 2009 Mastervolt. All rights reserved.

Reproduction, transfer, distribution or storage of part or all of the contents in this document in any form without the prior written permission of Mastervolt is prohibited.

This manual serves as a guideline for the safe and effective operation, maintenance, trouble shooting and configuration of the Mass GI.

It is therefore obligatory that every person who works with the Mass GI is completely familiar with the contents of this manual, and that he/she carefully follows the instructions contained herein.

Installation of, and work with the Mass GI, may be carried out only by qualified, authorised and trained personnel, consistent with the locally applicable standards and taking into consideration the safety guidelines and measures (chapter 3 of this manual).

Keep this manual at a secure place!

### 2.3 Guarantee specifications

Mastervolt guarantees that this unit has been built according to the legally applicable standards and specifications. Should work take place, which is not in accordance with the guidelines, instructions and specifications contained in this users manual, then damage may occur and/or the unit may not fulfil its specifications. All of these matters may mean that the guarantee becomes invalid.

The guarantee is limited to the costs of repair and/or replacement of the product. Costs for installation labor or shipping of the defective parts are not covered by this guarantee.

### 2.4 Validity of this manual

All of the specifications, provisions and instructions contained in this manual apply solely to standard

versions of the Mass GI delivered by Mastervolt, with part numbers: 88060705, 88000705 or 88000355. For other models see manuals available on [www.mastervolt.com](http://www.mastervolt.com).

### 2.5 Quality

During production and prior to delivery, all of our units are tested and inspected. The standard guarantee period is two years after date of purchase.

### 2.6 Liability

Mastervolt can accept no liability for:

- consequential damage due to Mass GI use;
- possible errors in the manuals and the results thereof.

### 2.7 Identification label

The identification label is located at the right-hand side of the Mass GI and in the connection compartment (see figure 1, 2). Important technical information required for service, maintenance & secondary delivery of parts can be derived from the identification label.

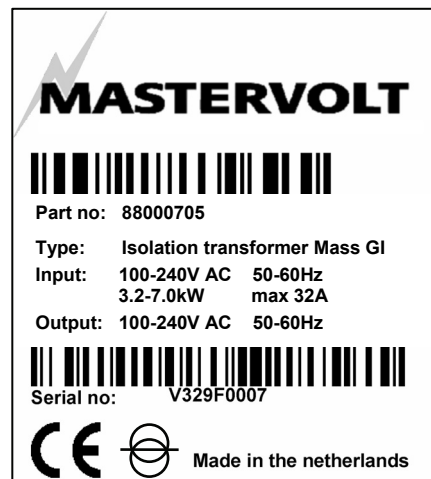

Figure 3: Identification label



CAUTION!

Never remove the identification label.

### 2.8 Changes to the Mass GI

Changes to the Mass GI may be carried out only after obtaining the written permission of Mastervolt.

## 3 SAFETY GUIDELINES AND MEASURES



### WARNING!

Before using the Mass GI, read and save these safety instructions.

### 3.1 Warnings and symbols

Safety instructions and warnings are marked in this manual by the following pictograms:



A procedure, circumstance, etc which deserves extra attention.



### CAUTION!

Special data, restrictions and rules with regard to preventing damage.



### WARNING

A WARNING refers to possible injury to the user or significant material damage to the GI if the user does not (carefully) follow the procedures.

### 3.2 Use for intended purpose

- 1 The Mass GI is constructed as per the applicable safety-technical guidelines.
- 2 Use the Mass GI only:
  - at the input connected to a dedicated double pole circuit breaker and earth leakage switch;
  - in a technical correct condition;
  - in a well-ventilated room, protected against rain, moist, dust and condensation;
  - observing the instructions in the users manual.



### WARNING

Never use the Mass GI in situations where there is danger of gas or dust explosion or potentially flammable products!

- 3 Use of the Mass GI other than mentioned in point 2 is not considered to be consistent with the intended purpose. Mastervolt is not liable for any damage resulting from the above.

### 3.3 Organizational measures

The user must always:

- have access to this manual;
- be familiar with the contents of this manual.

This applies in particular to chapter 3.

### 3.4 Maintenance & repair

- 1 If the Mass GI is switched off during maintenance or repair activities, it should be secured against unexpected and unintentional switching on:
  - Remove the AC supply
  - Be sure that third parties cannot reverse the measures taken.
- 2 Use original spare parts only.

### 3.5 General safety and installation precautions

- Install the Mass GI according to this manual.
- Connections, wiring, grounding and other safety features must be executed according to the locally applicable regulations.
- Use cables with an appropriate size.
- Use the Mass GI in accordance with the specifications as stated in section 12.1.
- Except for the connection compartment never open the housing as high voltages may be present inside!
- When opening the connection compartment, disconnect the AC-input first.
- Do not expose the Mass GI to rain, snow, spray, moisture, excessive pollution and condensing circumstances. To reduce risk of fire hazard, do not cover or obstruct the ventilation openings. Install the Mass GI in a well ventilated area to prevent overheating.
- The Mass GI must be provided with an equipment-grounding to the AC-input ground terminal.
- Check the wiring and connections at least once a year. Defects such as loose connections, burned cables etc. must be corrected immediately.
- Do not touch the equipment when wet or if your hands are clammy.
- Only allow changes in your electrical system to be carried out by qualified electricians.
- In case of fire, use a fire extinguisher for electrical equipment.

### 3.6 Warning regarding life support applications

The Mass GI products are not sold for applications in any medical equipment intended for use as a component of any life support system unless a specific written agreement pertaining to such intended use is executed between the manufacturer and Mastervolt.

## 4 HOW IT WORKS

In order to prevent electrical corrosion of metal parts on your ship while maintaining the onboard earth, a separation between the AC shore power and the onboard AC power is necessary.

As mentioned before, the Mass Isolating Transformer provides you with this separation. It is installed in between the AC shore power connection and the onboard AC loads. If 3.5 kW of shore power is not sufficient, more Mass GI's can be connected in parallel to increase the power up to 14 kW maximum. With the Mass GI's in parallel, power conversion will be divided between the units. See chapter 9 for more details.

### 4.1 MasterBus communication

The Mass GI communicates via the MasterBus network. This network is used for remote control and remote (alarm) monitoring of the Mass GI, for configuration (in parallel) and for communication with other system devices. See chapters 6 and 7 for more information.

### 4.2 Protection

The Mass GI is protected against overload, peak current, short circuit and high temperature. See section 5.1 for LED indications when a protection comes into effect.

#### 4.2.1 Overload protection

The Mass GI is equipped with an integrated fuse which limits the input current to 16A. This fuse will switch the Mass GI to Stand by in overload situations and trigger the MasterBus alarm.

#### 4.2.2 Second overload protection

The Mass GI is protected by a 20AT fuse as well. This fuse switches off the Mass GI input, there will be no MasterBus alarm.

To correct the situation *at the Mass GI 3.5*, proceed as follows:

1. Move the main switch of the Mass GI to the Standby position.
2. Disconnect the Mass GI from any power source. Disconnect all loads from the Mass GI.
3. Investigate the cause of failure of the thermal fuse like overload or short-circuits.
4. Refer to section 8.7 to open the connection compartment.

5. Wait for at least two minutes and then reset the 20AT fuse by pushing the button inside the connection compartment, see figure 1 ref.10.
6. Close the connection compartment again.
7. Connect the Mass GI to the power sources.
8. Switch on the Mass GI.

If the fuse trips again in short time, please contact your Mastervolt supplier for service.

*At the Mass GI 7.0 (MultiTap)* the 20AT fuse is located *inside the device*. Therefore corrections can only be performed by qualified technicians.

#### 4.2.3 Peak current limitation

The Mass GI is automatically protected against a peak current during a short period.

#### 4.2.4 Short circuit protection

The Mass GI is protected against a short circuit situation by a fuse which trips when during 1 second short circuit conditions are met. In case of short circuit, the Mass GI switches to Standby, the short circuit LED illuminates and the MasterBus alarm is triggered.

#### 4.2.5 Thermal protection

The Mass GI is protected against high temperature by 3 integrated thermal fuses. If one of these fuses trips, the Mass GI will switch to Stand by, the high temperature LED illuminates and the MasterBus alarm is triggered.

#### 4.2.6 MasterBus power supply protection

The MasterBus power supply (internal aux power supply) is protected by means of a 1A fuse.

## 5 OPERATION

The Mass GI can be activated by switching the main switch (figure 1, ref. 1) to the "ON" position. When no error is present, the green ON LED illuminates after this. The Mass GI will then generate an AC output voltage. Move the switch to the Standby position to switch off the Mass GI. In standby the Mass GI remains connected to the AC mains!

### 5.1 Resetting the Mass GI

When the Mass GI is in failure mode it can be reset in two ways:

1. By switching it Off and On again using the main switch (figure 1 ref. 1).
2. By using the MasterBus function Restart (section 7.1).

### 5.2 Maintenance

No specific maintenance is required. If necessary, use a soft clean cloth to clean the Mass GI. Never use any liquids, acids and/or scourers.

For reliable and optimum function examine your electrical installation on a regular base, at least once a year. Defects such as loose connections, burnt wiring etc. must be corrected immediately.

### 5.3 LED indicators

The operation of the Mass GI is displayed by means of front panel LEDs. See the table below for explanation.

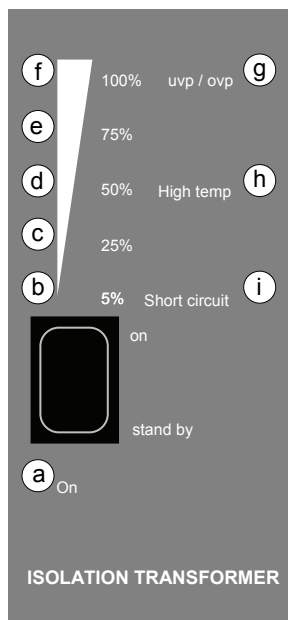

Illuminating LED	Status	Meaning
a	On	Mass GI is switched on.
a (blinking)	Waiting	Mass GI waits for parallel units to switch on.
a+b	Normal	Current conversion: 5% of nominal current.
a+b+c	Normal	Current conversion: 25% of nominal current.
a+b+c+d	Normal	Current conversion: 50% of nominal current.
a+b+c+d+e	Normal	Current conversion: 75% of nominal current.
a+b+c+d+e +f (yellow)	Normal	Current conversion: 100% of nominal current.
a+b+c+d+e +f (red)	Overload	Current conversion: >100% of nominal current, Mass GI will be shut off soon due to overload.
f (red)	Failure mode	Mass GI has been shut off due to overload.
g	Failure mode	Mass GI has been shut off due to too low or too high input voltage.
g (blinking)	Failure mode	Mass GI has been shut off due to a frequency error on the input.
h	Failure mode	Mass GI has been shut off due to too high temperature.
i	Failure mode	Mass GI has been shut off due to short circuit.

Table: Front LEDs with function

## 6 MASTERBUS

### 6.1 What is MasterBus?



All devices that are suitable for MasterBus are marked by the MasterBus symbol.

MasterBus is a fully decentralized data network for communication between the different Mastervolt system devices. It is a CAN-bus based communication network which has proven a reliable bus-system in automotive applications. MasterBus is used as power management system for all connected devices, such as the inverter, battery charger, generator and many more. This enables communication between the connected devices, for instance to start the generator when the batteries are low.

MasterBus reduces complexity of electrical systems by using UTP patch cables. All system components are simply chained together. The results are a reduction of material costs as only a few electrical cables are needed and less installation time.

For central monitoring and control of the connected devices Mastervolt offers a wide range of panels

which show full status information of your electrical system at a glance and a push of a button. All monitoring panels can be used for monitoring, control and configuration of all connected MasterBus devices.

New devices can be added to the existing network in a very easy way by just extending the network. With this the MasterBus network offers a high degree of flexibility for extended system configuration, not only today, but in the future as well!

Mastervolt also offers several interfaces, making even non-MasterBus devices suitable to operate in the MasterBus network.

For direct communication between the MasterBus network and a product which is not from Mastervolt, the Modbus interface is recommended.



**CAUTION:** Never connect a non-MasterBus device to the MasterBus network directly! This will void warranty of all MasterBus devices connected.

The *event* configuration of the Mass GI as target and as source is described in chapter 7 of this manual.

## 6.2 How to set up a MasterBus network

Every device suitable for the MasterBus network is equipped with two data ports. When two or more devices are connected by these ports, they form a local data network, called the MasterBus. Keep the following rules in mind:

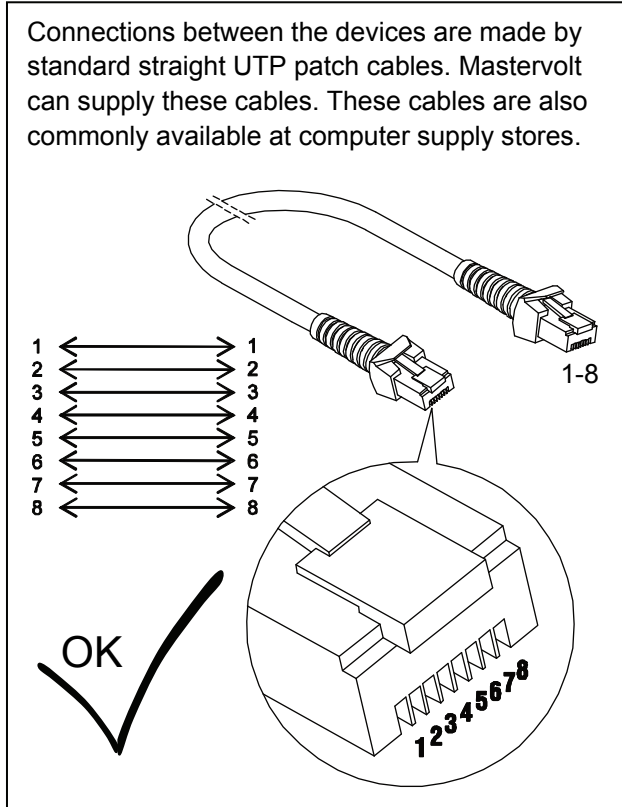

Figure 4

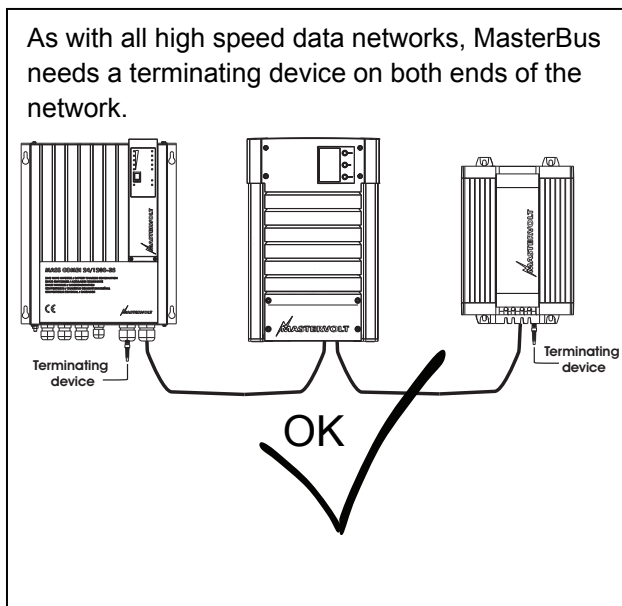

Figure 5

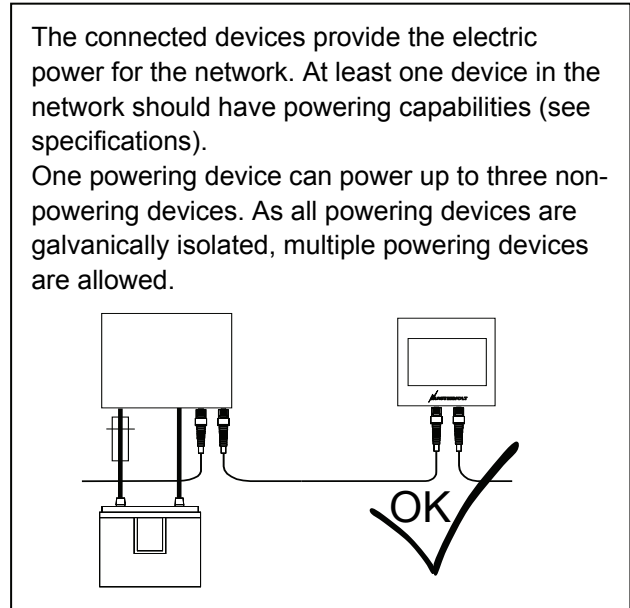

Figure 6

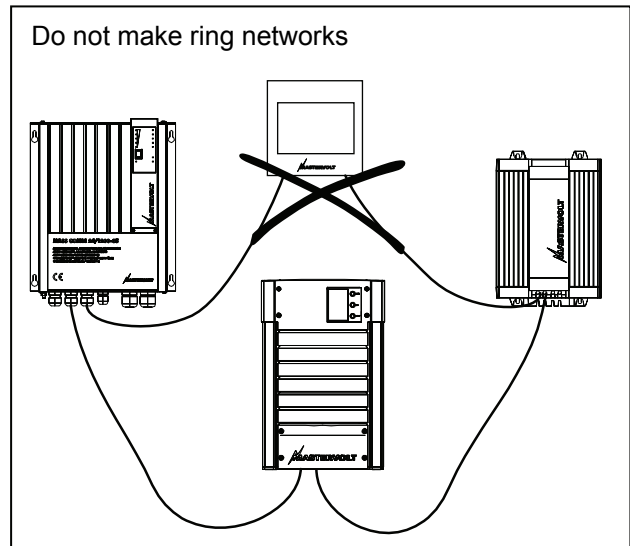

Figure 7

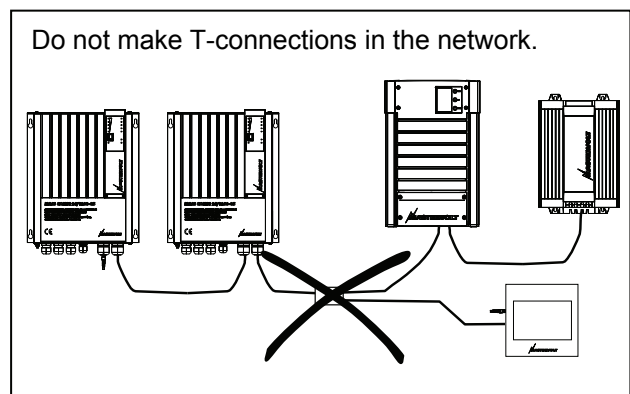

Figure 8

## 7 MASTERBUS ON THE MASS GI

### 7.1 Monitoring

Variable	Description	Default	Range
State	Mass GI status	-	OK, Standby, No shore, Waiting, Load high, Overload, Short circuit, Configuration fault
Shore fuse	Set maximum shore fuse current (Mass GI 3.5 kW)	16A	2A, 4A, 6A, 10A, 14A, 16A, Unlimited
Shore fuse	Set maximum shore fuse current (Mass GI 7.0 kW/ 7.0 kW Multitap)	32A	4A, 8A, 12A, 20A, 28A, 32A, Unlimited
Restart	Switching function (no front switch override)		
Input voltage	Voltage at input of the GI	-	0-300 V
Input current	Current at input of the Mass GI	-	0-16 A
Power	Input power of the Mass GI	-	0-5.0 kW
Frequency	Input frequency	-	35-70 Hz

### 7.2 Alarm

Variable	Description
Voltage high	Input voltage over 253V.
Voltage low	Input voltage under 90V.
Temperature high	The internal temperature is higher than 90°C/194°F, the Mass GI is in Failure mode.
Short circuit	A too high current has been measured during a predetermined period of time.
Overload	The load on the output is too high.
Frequency fail	The input frequency is out of range: below 45Hz or over 65Hz.

### 7.3 History

Category	Variable	Description
AC present	Time	Period shore power has been present since latest shore power connection.
	Energy	Energy consumed since latest connection to shore power.
	Max A	Maximum input current since latest connection to shore power.
	Average A	Average input current during latest connection to shore power.
	Max V	Maximum input voltage since latest connection to shore power.
	Average V	Average input voltage during latest connection to shore power.
	Min V	Minimum input voltage since latest connection to shore power.
AC not present	Time	Time elapsed when no shore power was available.
Total	Runtime	Total operating time since first use of the Mass GI.
	Energy	Total energy consumed since first use of the Mass GI.
	Average A	Average total input current since first use of the Mass GI.
Latest alarms	Latest	Select an alarm to see the values of (maximum 9 alarms can be stored).
	Alarm	Shows the present alarm if applicable.
	Input voltage	Input voltage at detection of the alarm shown.
	Output voltage	Output voltage at detection of the alarm shown.
	Output current	Output current at detection of the alarm shown.

### 7.4 Configuration general

Variable	Description	Default	Range
Language	Set the Mass GI menu language.	English	See specifications
Device name	Any name with 12 characters max.	Mass GI	Max 12 characters

### 7.5 Reset settings

Variable	Description
Reset settings	This option allows resetting the Mass GI to default (factory) settings.

## 7.6 Event Configuration

In Event configuration, changing variables of the Mass GI can be used to trigger other devices.

Variable	Description	Default	Range
Event x source	Event by the Mass GI that should result in an action by one of the other devices on the MasterBus network. Nine events are available: x can be 1-9	Disabled	See section 7.7 Event source list
Event x target	Select a connected MasterBus device that should take action due to a Mass GI event.	Select...	Selectable targets are system dependent.
Event x command	Action to be taken by the target device.	Select...	See command list in manual of the selected device. Mass GI section 7.8.
Event x data	Data is linked to the command. See also figure 9.	Off	Off, On, Copy, Copy Invert, Toggle.

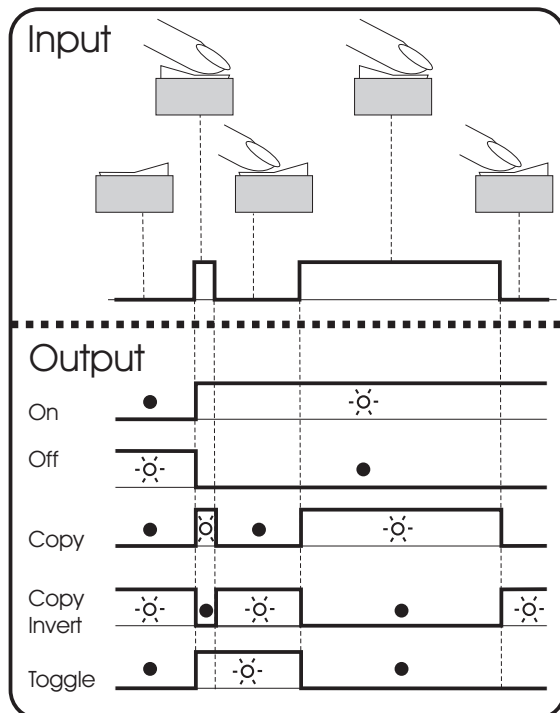

Figure 9: Event data

Figure 9 shows the meaning of the event data.

- **Input** is a pulse followed by a longer signal (1/0).
- **On** changes the status to On at the first signal.
- **Off** changes the status to Off at the first signal.
- **Copy** lets the status follow the input.
- **Copy Invert** lets the status follow the opposite of the input.
- **Toggle** changes the status at the first signal and back at the second signal. It is often used in combination with a pulse switch.

## 7.7 Mass GI Event Source List

Variable	Description
Load 5%	Mass GI load is 5% of maximum.
Load 25%	Mass GI load is 25% of maximum.
Load 50%	Mass GI load is 50% of maximum.
Load 75%	Mass GI load is 75% of maximum.
Load 100%	Mass GI load is 100% of maximum.
Pre overload	Mass GI is going to be in overload if the actual situation lasts.
Fan on	The internal fan is switched on.
Failure mode	Mass GI is in failure mode

## 7.8 Mass GI Event Target List

Variable	Description	Range
Restart	Restart the Mass GI	

## 8 INSTALLATION STAND ALONE

In this chapter we describe the installation of a stand alone Mass GI. Chapter 9 describes the installation of Mass GI's in parallel.

### 8.1 Unpacking

The delivery consists of the following parts:

- Mass GI
- MasterBus cable (in connection compartment)
- MasterBus terminator (in connection compartment)
- This user's manual. Save this manual at a secure place!

After unpacking, check the Mass GI for possible damage. Do not use the Mass GI if it is damaged. If in doubt, contact your supplier.

### 8.2 Before you start

- Be sure that the output of the supplying source is switched off during the entire installation.
- Make sure the main switch is set to the Standby position. See fig 1, ref 1.
- Do not connect the AC-output of the Mass GI to an incoming AC source.

### 8.3 Extra materials needed

Every Mass GI is mounted to the wall using four screws (with rings and plugs), recommended size m8. Use suiting materials to carry the weight of the Mass GI.

### 8.4 Cable sizes

Undersized cables and/or loose connections can cause dangerous overheating of the cables and/or terminals. In order to limit transition resistance as far as possible, use proper cable sizes and tighten all connections well. See table below to select the appropriate cross section for the AC wiring:

Model	AC Current	Min. cross section	AWG
Mass GI 3.5	0-16 A	2.5 mm <sup>2</sup>	13
Mass GI 7.0	16-35 A	6.0 mm <sup>2</sup>	8

### 8.5 Choosing the location to install

Obey the following stipulations during installation:

- Install the Mass GI in a well-ventilated room protected against rain, vapour, moisture and dust.
- Ambient temperature: 0-40°C, Humidity: 0-90% non condensing.

- Never use the Mass GI at a location where there is danger of gas or dust explosions.
- Mount the Mass GI in such a way that obstruction of the airflow through the ventilation openings is prevented. No objects must be located within a distance of 10 cm / 4 inch around the Mass GI.
- For optimum air flow, the MASS GI should always be mounted vertically, this means with the cable glands facing downwards.

### 8.6 Mounting of the cabinet to a wall

Take the following steps to mount the cabinet:

1. Determine the four mounting spots using the outline drawings (section 12.2).
2. Fix the mounting screws into the surface but do not tighten them entirely.
3. Place the housing over the screws.
4. Fix the housing by fastening the screws securely.

### 8.7 Opening the connection compartment

The connection compartment must never be opened while the Mass GI is connected to a power source.

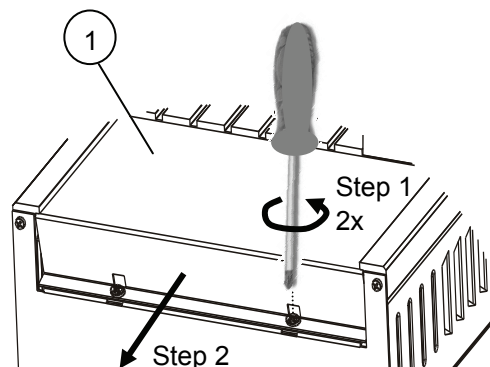

Figure 10

See figure 10. Steps:

1. Loosen the two Phillips screws A and B that secure the front cover plate (1) for two turns.
2. Slide the front cover plate (1) from the cabinet (downwards).
3. The terminals and fuse button are accessible now.

## 8.8 Cabling

The wiring is connected inside the connection compartment. If necessary, the cabling can be fed from the top to the bottom side of the cabinet along the back of the cabinet. Always feed the wiring through the cable glands (fig.1 ref. 5) of the cabinet, and then connect the wiring to the terminals. Cut the wiring as shown in figure 11. Strip the conductors for 8 mm.



The diameter of the outer isolation must be between 10 and 14 mm to fit in the cable glands correctly enabling strain relieve.

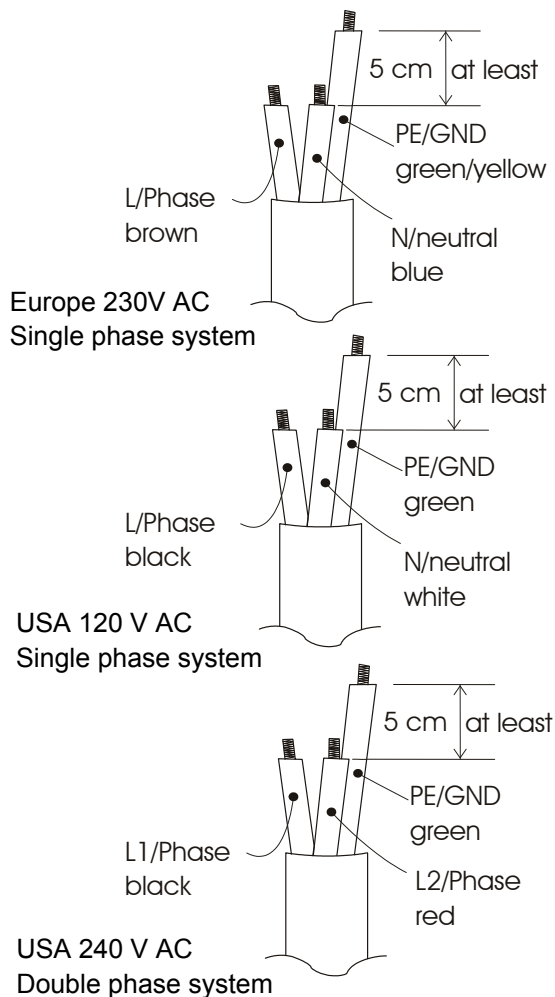

Figure 11: Wiring



### WARNING

Never connect Earth (input) to Protective Earth (output)!



For safe installation it is necessary to:

- Connect both the earth (PE/GND) and the neutral (N) of the AC output of the Mass GI to the grounding point, fig. 16. This grounding point must be connected to the central ground connection of the ship, which is connected to the hull of the ship.
- Integrate a Residual Current Device (RCD) in wiring of the AC output.

Refer to local applicable regulations on these issues.

## 8.9 Connection

Steps:

1. Connect the AC load to the AC output (fig.16).
2. Connect the incoming shore power via a circuit breaker to the AC input (fig.15). Phase line to L, Neutral to N, and Ground to PE/GND.

## 8.10 Commissioning after installation

1. Tighten all cable glands (fig. 1, ref. 5) to ensure the strain relief.
2. Check all wiring and connections.
3. Close the front cover plate of the connection compartment. Beware that the cabling does not obstruct the cooling fan (fig. 1, ref.11) and air flow.

Now the Mass GI is ready for operation!

## 9 TWO TO FOUR MASS GI'S IN PARALLEL (ADDITIONAL INFO)

For shore connections of more than 16A (32A), multiple Mass GIs can be used in parallel (maximum four Mass GI 3.5 or two Mass GI 7.0/ Mass GI 7.0 MultiTap).



### CAUTION!

In parallel, all inputs must be connected to the same phase!



### WARNING!

Never connect the output(s) to any other power source!

See figure 12 for installation. Steps:

1. Connect the MasterBus cable between the communication ports on the Mass GI's.
2. Connect the AC load to the AC output on the units (figure 16).

3. Connect the incoming shore power to the AC input on your Mass GI's. Phase line to L, Neutral to N, and Ground to PE (figure 17).

### 9.1 Installation of four Mass GI's in parallel (Mass GI 3.5 only)

Extra materials needed for 4 Mass GI's: 16 screws (with rings and plugs), size m8. Use suiting materials to carry the weight of the Mass GI.

If you have more than four Mass GI's to put in parallel, you need to install two groups, using manual setup.



To achieve maximum performance all input and output wiring must be of equal length. For more than two Mass GI's we recommend a star configuration like shown in figure 12.

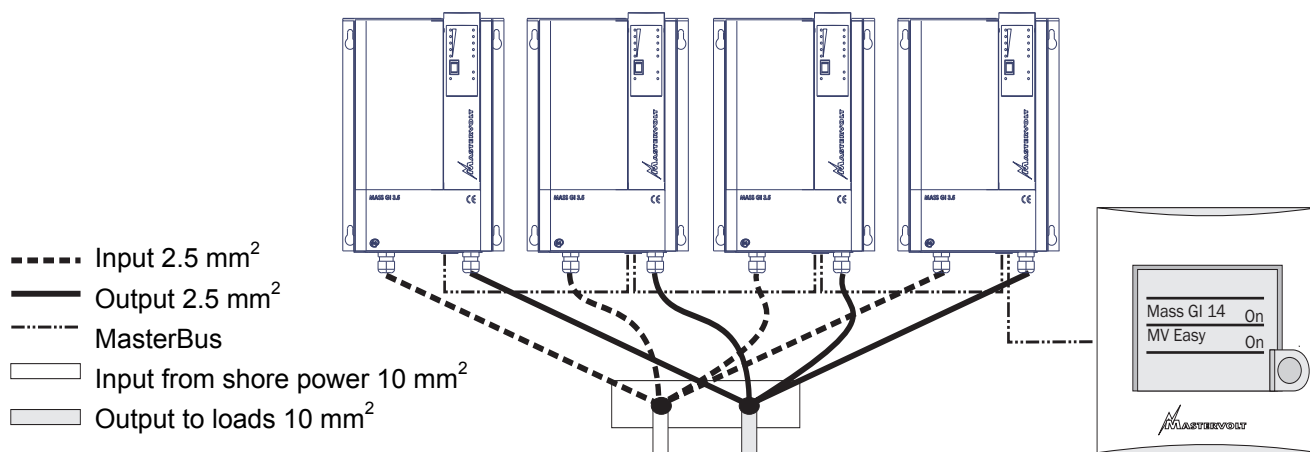

Figure 12: Parallel connection of four Mass GI 3.5 in one group

### 9.2 Parallel operation in one group

In one group all Mass GIs in the MasterBus network run in parallel. Parallel configuration is done automatically via MasterBus communication. When two, three or four units are detected in a MasterBus network, the system assumes that these operate in parallel.

### 9.3 Multiple groups of Mass GI(s) in parallel

With more than four Mass GI's in parallel you need more than one group. For example 8 Mass GI's can be configured as two groups of four Mass GIs running in parallel. In this situation additional configuration of the system is required. Per group of GI's one of the units needs to be assigned the status of Master. In "Configuration" > "Parallel" one should

select "Master". After this action the required number of Mass GIs can be selected to run in parallel to the Master via selection in Product 1, Product 2, Product 3 and Product 4. Note Product 1 is the product that was selected as Master.



Rename Mass GIs before configuring multiple groups of GIs. For example "Transformer 1" etc.



If the automatic paralleling of Mass GI's is not desirable, select "Master" on the units in parallel configuration and do not select additional products to run in parallel. This effectively creates single units that will not switch to parallel mode automatically.

## 9.4 Safety devices in parallel configuration

The figure below shows the recommended safety devices and their rates for parallel configuration. At the input only one circuit breaker is sufficient, given the fuse is rated according to the total input current.

At the output, each Mass GI shall be provided with a circuit breaker and the common output must contain a residual current device suitable for the total output current.

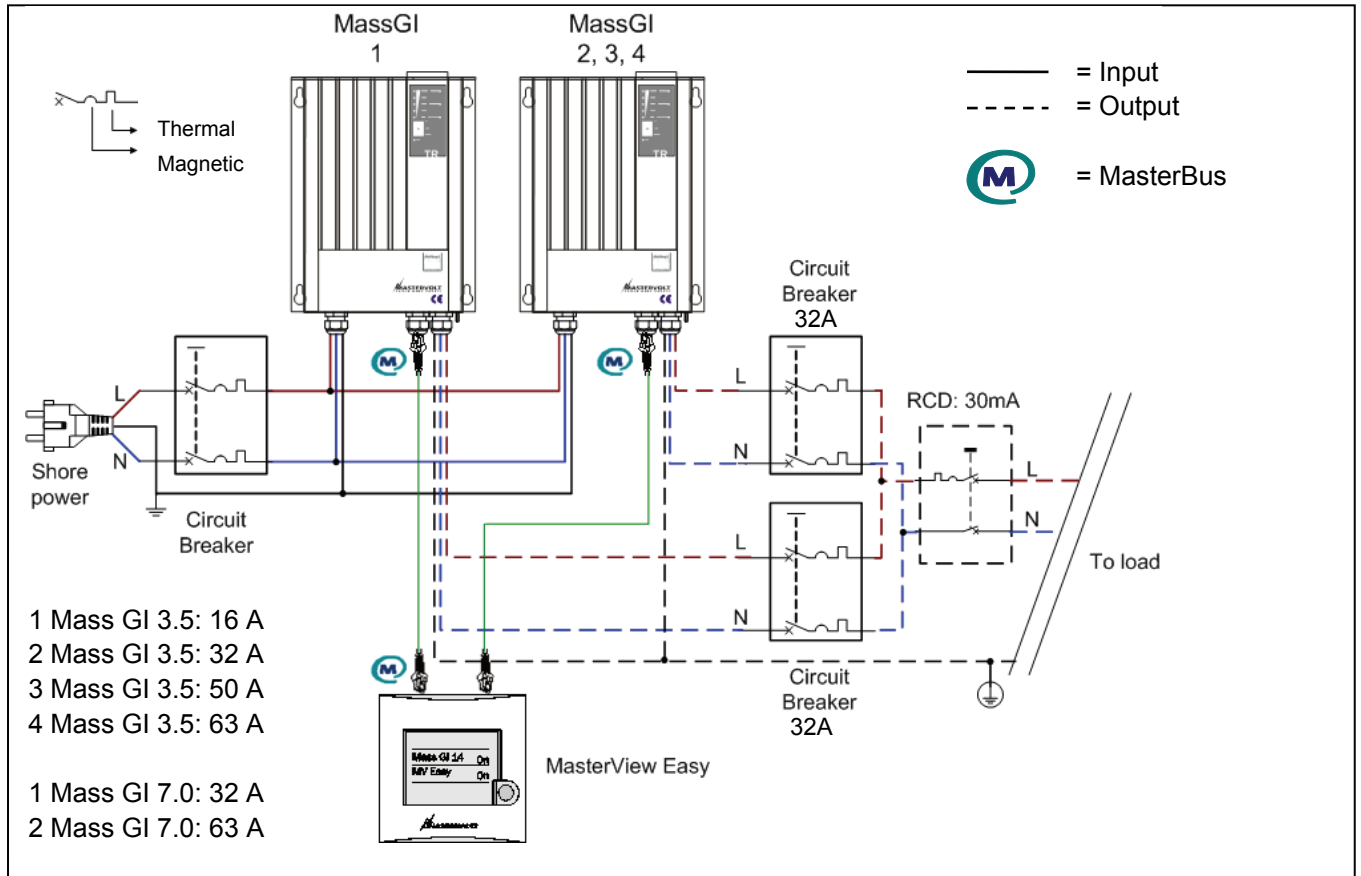

Figure 13: Safety devices with paralleled Mass GI.

## 10 QUICK INSTALLATION

**1** This section provides a brief overview of a basic stand alone installation of the Mass GI. However; please review the entire manual for connection of additional features and to ensure best performance and years of trouble-free service.

**2** The electrical system must be disconnected from any power source during the entire installation!

**3** Mount the Mass GI to a vertical surface. Allow at least 10 cm / 4 inch space around the apparatus!

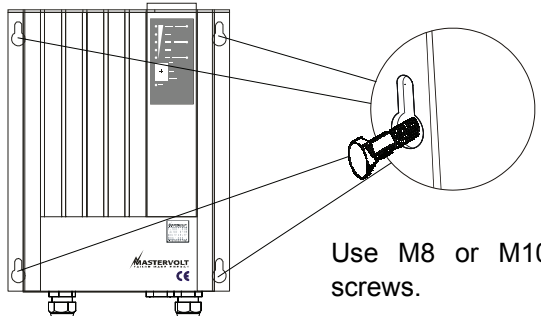

Use M8 or M10 screws.

Figure 14

**4** Open the connection compartment:

- Loosen the two Philips screws that secure the front cover plate for two turns.
- Slide the front cover plate from the cabinet.

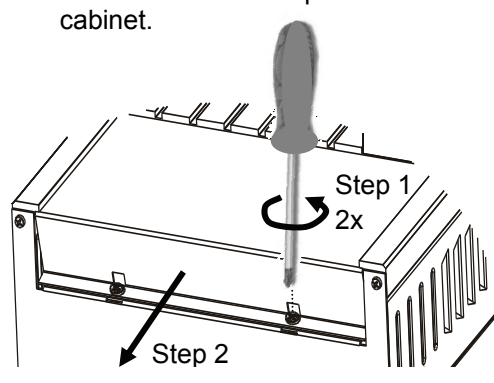

Figure 15

**5** Connect the AC load to the Mass GI AC output. We recommend to connect both the AC output earth (PE) and the neutral (N) to the central grounding point which is connected to the hull of the ship, using a Residual Current Device (RCD) in the wiring of the AC output. Refer to local applicable regulations.

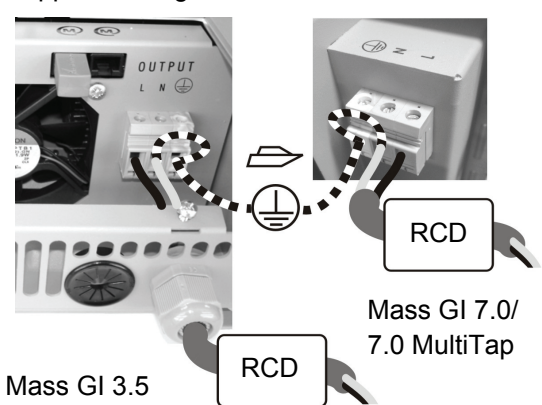

Figure 16

**6** Connect the contra plug for incoming shore power via an external circuit breaker to the AC input terminal of the Mass GI. **Phase line to L, Neutral to N, Ground to PE.** Do NOT connect the ground wire (PE) of the shore power to the central grounding point (hull of the ship), neither to the PE connection of the output or to the Mass GI enclosure!

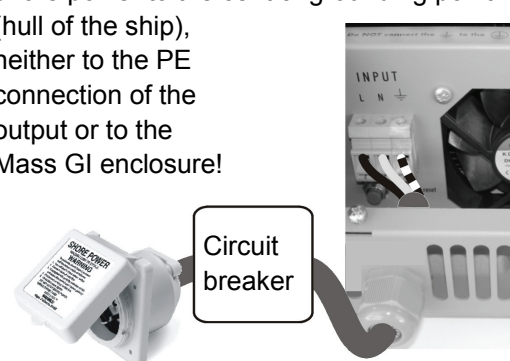

Figure 17

**7** Close the connection compartment. Connect shore power to the Mass GI. Switch On the Mass GI. Check LED "On" and ensure that failure LEDs are Off. In case of failure, disconnect shore power and check Mass GI.



Figure 18

## 11 TROUBLE SHOOTING

See section 5.3 for LED indicators.

Problem	Possible cause	What to do?
No output power, all LED indicators are off.	Main switch is in position STAND BY.	Switch ON the Mass GI. See chapter 5.
	No shore power available on AC input.	Check the circuit breaker of the shore power (on the quay). Check the wiring of the shore power cable.
	20AT fuse has tripped.	Reset the fuse (see section 4.2.2).
No output power, only the On LED (figure 1, ref. 2) illuminates.	External RCD has tripped.	Mass GI is working normally. Check the external RCD at the AC output (if applied).
No output power, OVP/UVP LED is on.	Input voltage is/ was either too high or too low.	Check the input voltage. Then reset the Mass GI by switching it Standby, On or by using Restart (MasterBus).
No output power, OVP/UVP LED is blinking.	Input frequency is/ was either too high or too low.	Check the input frequency. Then reset the Mass GI (see section 5.2).
No output power, High temp LED is on.	Environmental temperature is too high.	Check temperature. Reduce load and let the Mass GI cool down. Then reset the GI (see section 5.2).
	Fan is blocked.	Make sure the fan is not blocked by the wiring of the connection compartment. See section 8.7 to open the connection compartment.
	Too much load connected.	Reduce the connected load. Then reset the Mass GI (see section 5.2). Use an extra GI in parallel.
No output power, Short circuit LED is on.	Short circuit at the output.	Remove the short circuit. Then reset the Mass GI (see section 5.2).
No output power, "100%" LED illuminates red.	Overload.	Reduce the connected load. Then reset the Mass GI (see section 5.2).
MasterView Easy panel connected to the GI, no communication.	The Easy panel has been switched off or MasterBus is not working correctly.	Check MasterBus wiring, a terminator should be placed on both ends of the MasterBus network.
Parallel units are shut off due to overload while load is less than 3.5 (7.0) kW per unit.	Installation fault.	Cable lengths and thickness must be of the same size for all units. See chapter 9.
No MasterView display function.	Display is switched off.	Switch on display, refer to display manual.
	Error in the wiring.	Check the MasterBus cables.
	No powering device available on the MasterBus.	With shore power disconnected the Mass GI does not power the MasterBus network. At least one other connected MasterBus device should have powering capabilities.
Slow or no MasterBus communication.	Error in the MasterBus wiring.	Check the MasterBus cables.
	No terminating device placed at the ends of the network.	MasterBus needs a terminating device on both ends of the network. Check if connected (see section 6.2).
	MasterBus network is configured as a ring network.	Ring networks are not allowed. Check the connections of the network (see section 6.2).

## 12 TECHNICAL DATA

### 12.1 Specifications

Model	MASS GI 3.5	MASS GI 7.0	MASS GI 7.0 MultiTap
Article number:	88000355	88000705	88060705
Nominal power:	3500VA @ 230V	7000VA @ 230V	7000VA @ 230V/ 3500VA @ 120V
<i>Input</i>			
Input voltage:	90-255V	90-255V	90-145VAC or 180-255VAC
Input frequency:	45..65Hz	45..65Hz	45..65Hz
Nominal input current:	16A cont	32A cont	32A cont
No load AC current consumption:	≤ 60 W rms	≤ 60 W rms	≤ 60 W rms
Standby AC current consumption:	≤ 600 mA rms/ 11W	≤ 600 mA rms/ 11W	≤ 600 mA rms/ 11W
DC current consumption, no MasterBus traffic:	≤ 10mA	≤ 10mA	≤ 10mA
Earth leakage protection:	Not present inside, an external RCD is required		
<i>Output</i>			
Output voltage:	Same as input voltage ± 5%	Same as input voltage ± 5%	230V ± 5%
Output frequency:	Same as input frequency	Same as input frequency	Same as input frequency
Output current behavior:	Fuse B characteristic	Fuse B characteristic	Fuse B characteristic
Efficiency (max):	>93%	>93%	>93%
MasterBus powering capability	Yes, if shore power is present	Yes, if shore power is present	Yes, if shore power is present
<i>Options</i>			
Remote panel:	Optional, MasterView panel.	Optional, MasterView panel.	Optional, MasterView panel.
Parallel operation:	Yes, up to four units can be paralleled.	Yes, up to two units can be paralleled.	Yes, up to two units can be paralleled.
<i>Environment</i>			
Dimensions L x W x H:	371x261x145 mm / 14.6x10.3x5.7 inch	371x261x232 mm / 14.6x10.3x9.1 inch	371x261x232 mm / 14.6x10.3x9.1 inch
Approximate weight:	5.6 kg (12 lbs)	10 kg (22 lbs)	10 kg (22 lbs)
Specified operation temperature: (will meet specified tolerances)	Full specifications from 0°C/32°F to 40°C/104°F. Derating: 5%/°C (3%/°F) at ambient temperatures from 40°/104°F to 60°C/140°F. Shutdown at 90°C/194°F heat sink temperature.		
Allowed operating temperature: (may not meet specified tolerances)	-20°C/-4°F to 60°C/104°F	-20°C/-4°F to 60°C/104°F	-20°C/-4°F to 60°C/104°F
Non operating temperature: (storage temperature)	Ambient temperature - 40°C/-40°F to 100°C/212°F	Ambient temperature - 40°C/-40°F to 100°C/212°F	Ambient temperature - 40°C/-40°F to 100°C/212°F
Relative humidity:	Max 95% relative humidity, non condensing.		
Environment class:	IP 21	IP 21	IP 21

NOTE: specifications are subject to change without prior notice.

## 12.2 Dimensions

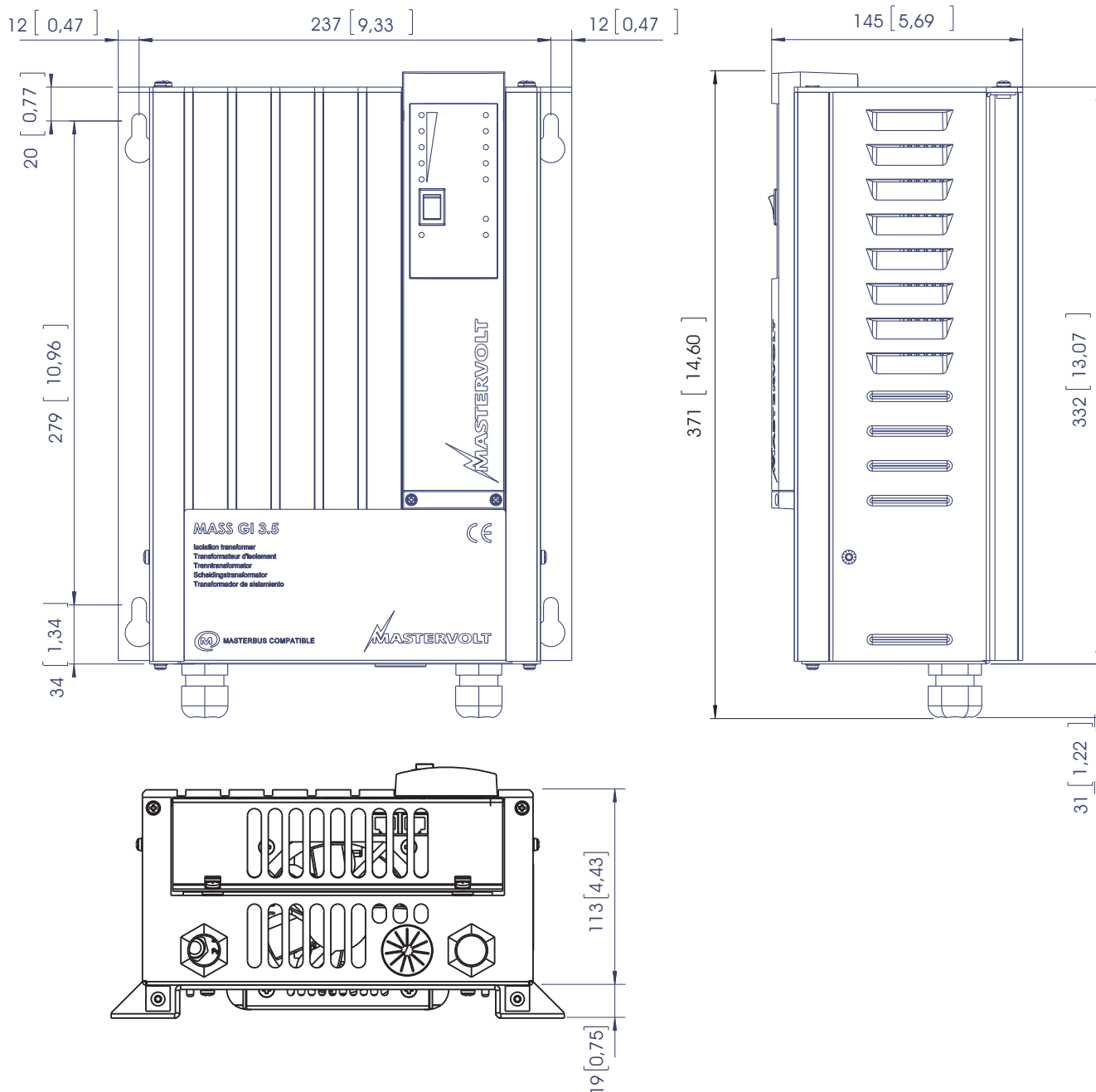

Figure 19: Dimensions in mm [inch] of Mass GI 3.5

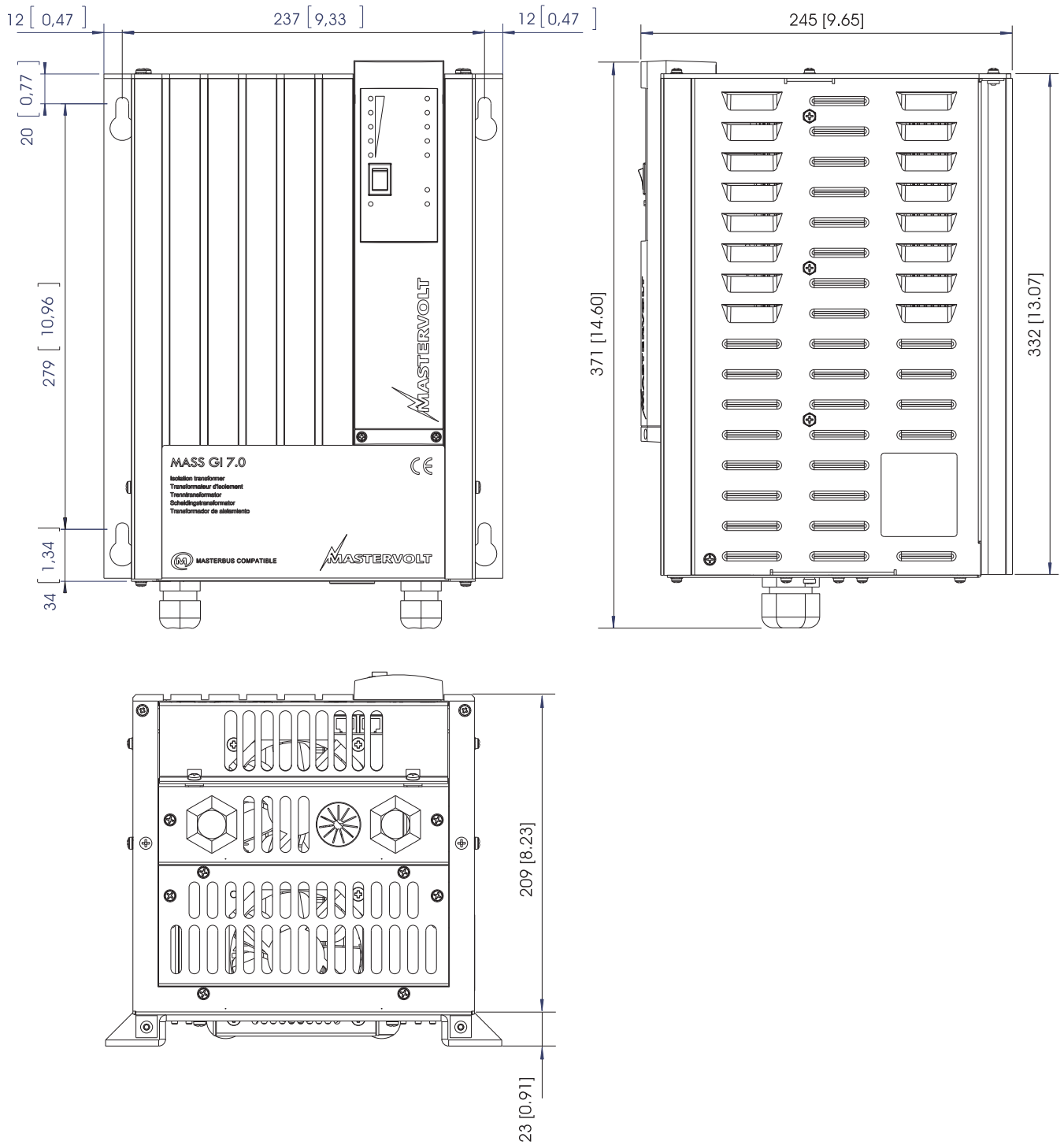

Figure 20: Dimensions in mm [inch] of Mass GI 7.0 and Mass GI 7.0 MultiTap

**13 EC DECLARATION OF CONFORMITY**

Manufacturer: Mastervolt  
Address: Snijdersbergweg 93  
1105 AN Amsterdam  
The Netherlands



Herewith declares that:

Product:

88000355 Mass GI 3.5  
88000705 Mass GI 7.0  
88060705 Mass GI 7.0 MultiTap

Is in conformity with the  
Low Voltage Directive 2006 / 95 / EC

With standards: EN 60950-1 : 2001  
EN 61558-1 : 2005  
EN 61558-2-4 : 1997

Recreational Craft Directive 94 / 25 / EEG

With standard: NEN-ISO 13297 : 2000

Electromagnetic Compatibility Directive 2004 / 108 / EC

With standards: EN 61000-6-1 : 2007  
EN 61000-6-2 : 2007  
EN 61000-6-3 : 2007  
EN 61000-6-4 : 2007

Amsterdam,

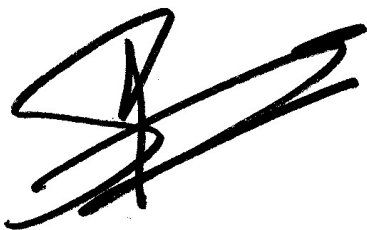

P.F. Kenninck,  
C.E.O. MASTERVOLT



Snijdersbergweg 93, 1105 AN Amsterdam, The Netherlands

Tel : + 31-20-3422100

Fax : + 31-20-6971006

Email : [info@mastervolt.com](mailto:info@mastervolt.com)