

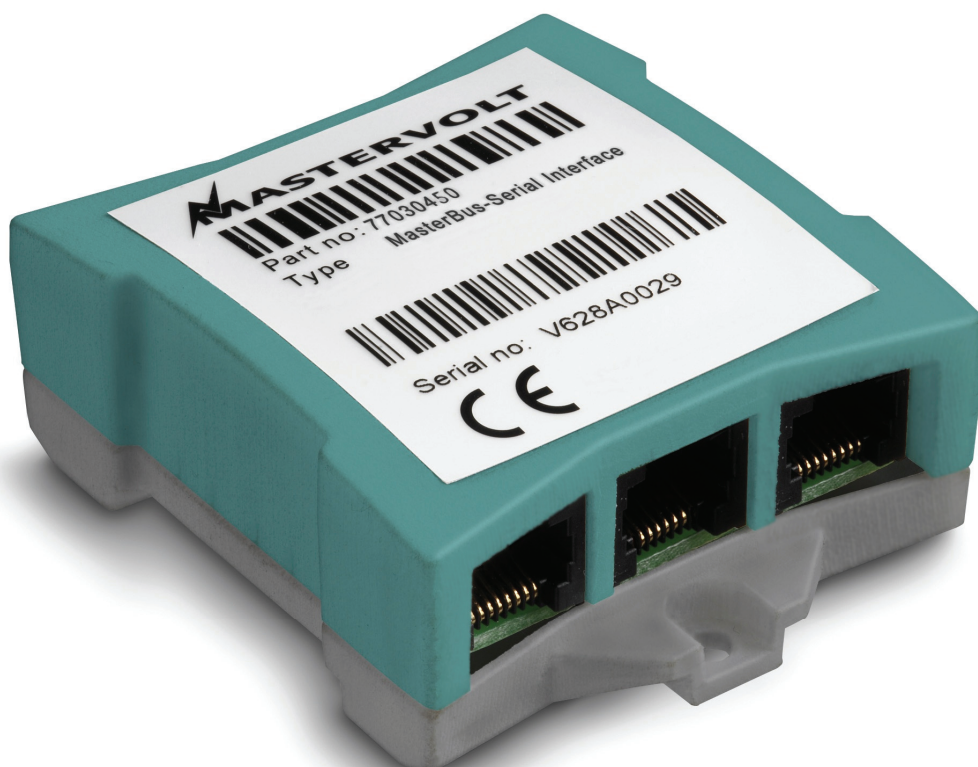

USERS MANUAL

MasterBus – Serial Interface

Interface between serial bus and MasterBus network



MASTERVOLT
Snijdersbergweg 93,
1105 AN Amsterdam
The Netherlands
Tel.: +31-20-3422100
Fax.: +31-20-6971006
www.mastervolt.com

ENGLISH

v 2.1 February 2008

CONTENTS:

v 2.1 February 2008

1	GENERAL INFORMATION.....	2
2	MASTERBUS.....	3
3	INSTALLATION	3
4	COMMUNICATION	4
5	ORDERING INFORMATION.....	6
6	TROUBLE SHOOTING.....	6
7	TECHNICAL INFORMATION	7
8	EC DECLARATION OF CONFORMITY	8

1 GENERAL INFORMATION

1.1 USE OF THIS MANUAL

This manual serves as a guideline for the safe and effective operation, maintenance and possible correction of minor malfunctions of the *MasterBus - Serial interface*.

This manual is valid for the following models:

Description	Part number
MasterBus - Serial interface	77030450

Keep this manual at a secure place!

The English version has 8 pages.

1.2 IMPORTANT TO KNOW

Incorrect installation may lead to damage to the MasterBus-Serial interface and the connected Mastervolt devices. Be sure that all equipment is disconnected from any power source during installation.

1.3 GUARANTEE SPECIFICATIONS

Mastervolt guarantees that this product was built according to the legally applicable standards and stipulations. If you fail to act in accordance with the regulations, instructions and stipulations in this user's manual, damage can occur and/or the product will not fulfil the specifications. This may mean that the guarantee will become null and void.

IMPORTANT: Additional warranty agreements, like "Mastervolt system warranty" may contain restrictions which forbid resetting of historical data

1.4 LIABILITY

Mastervolt can accept no liability for:

- Consequential damage resulting from the use of the MasterBus-Serial interface and/or the MasterAdjust software;
- Possible errors in the included manuals and the consequences of these.
- Use that is inconsistent with the purpose of the product

2 MASTERBUS

2.1 WHAT IS MASTERBUS?



All devices that are suitable for MasterBus are marked by the MasterBus symbol.

MasterBus is a fully decentralized data network for communication between the different Mastervolt system devices. It is a CAN-bus based communication network which has proven itself as a reliable bus-system in automotive applications. MasterBus is used as power management system for all connected devices, such as the inverter, battery charger, generator and many more. This enables communication between the connected devices, for instance to start the generator when the batteries are low.

MasterBus reduces complexity of electrical systems by using UTP patch cables. All system components are simply chained together. Therefore each device is equipped with two MasterBus data ports. When two or more devices are connected to each other through these data ports, they form a local data

network, called the MasterBus. The result is a major reduction of material costs and installation time as only a few electrical cables are needed to connect the devices.

For central monitoring and control of the connected devices Mastervolt offers a wide range of panels which show full status information of your electrical system at a glance and a push of a button. Four different panels are available, from the small Mastervision compatible 120 x 65mm LCD screen up to the full colour MasterView System panel. All monitoring panels can be used for monitoring, control and configuration of all connected MasterBus equipment.

New devices can be added to the existing network in a very easy way by just extending the network. This gives the MasterBus network a high degree of flexibility for extended system configuration, today and in future!

For information how to set up a MasterBus network refer to the manual of your MasterView display.

3 INSTALLATION

3.1 CONNECTION

What you need:

- MasterBus-Serial interface (included)
- MasterBus connection cable (included, 6m)
- RS232 crossed wire (included)

See figure 1

- Insert the MasterBus connection cables into the MasterBus data ports of the MasterBus – Serial interface.
- Connect the Serial connection cable between the MasterBus – Serial interface and the Serial port of your device.



Only the RS232 devices mentioned in chapter 4 are suitable for using the MasterBus-Serial interface.

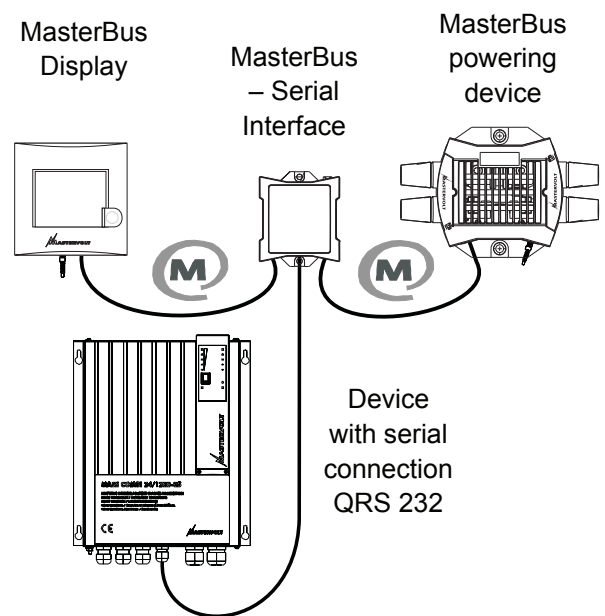

Figure 1: MasterBus-Serial interface in system

4 COMMUNICATION

The MasterBus-serial interface connects your non-MasterBus device to the MasterBus network. This enables monitoring and configuration with a MasterView display or the MasterAdjust software.

This chapter offers an overview of the MasterBus functions that are available with your device. These will show on a MasterBus display like the MasterView Easy or on a MasterAdjust screen.

4.1 MASS CHARGER

Monitoring, Alarm and Configuration menu.

MONITORING

Settings	Variables
Device	State Charge state DC Voltage DC Current

ALARMS

Settings	Variables
Alarm	Sense failure High temperature Short circuit DC error TC error

CONFIGURATION

Settings	Variables
Serial inter.	Language Device type
Bulk settings	Bulk voltage Bulk time Bulk return time
Absorption	Abs. voltage Max. absorp. time Min. absorp. time
Float settings	Float voltage, Force float vo.
Alarm settings	DC Alarm high On DC Alarm high Off DC Alarm low On DC Alarm low Off DC Alarm delay
Extra settings	Bulk return volt Return amps Max. current Diode compensate Temp. compensate Gel compensate

4.2 MASS COMBI

Monitoring and Configuration menu.

MONITORING

Settings	Variables
Basic setup	Mode Input select
State	State Load (%)
Charger	Charge state Battery voltage Charge current
AC input	AC input (V) AC input (A)
AC output	AC output (V) AC output (A)

CONFIGURATION

Settings	Variables
Serial interface	Language Device type
Bulk settings	Maximum current Bulk voltage Bulk time Bulk return time
Absorption	Abs. voltage Max. absorp. time Min. absorp. time
Float settings	Float voltage Force float vo.
Alarm settings	DC Alarm high On DC Alarm high Off DC Alarm low On DC Alarm low Off DC Alarm delay All error Battery voltage AC out, AC load, Load level
Extra settings	Bulk return volt Return amps Temperature compensate Gel compensate Inverter voltage Generator limit
Jumpers	Parallel mode Inverter frequency Energy mode Battery type Ground relay Power sharing, Power support, Mains support Power quality Equalize
Events	Event 1 source

4.3 MAC/ MAGIC

Monitoring and Configuration menu.

MONITORING

Settings	Variables
Mac/Magic	Mode On (yes, no) Input voltage Output voltage Output current Dimmer percentage

CONFIGURATION

Settings	Variables
Serial interface	Language Device type
Main	Mode Nominal voltage Use dipswitches Remote switch Shutdown voltage Low input off (V) Low input on (V) High input off (V) High input on (V) Delay time Current limit (%)
Stabilize	Force float (V)
Dimmer	Dimmer low (V) Dimmer high (V) Keep
Charger	Start new cycle (V) New charge cycle (V) Absorption time Absorption (V) Float (V)

4.4 BTM-III

Monitoring, History and Configuration menu.

MONITORING

Settings	Variables
Bank 1	State of charge Time remaining Ah consumed Battery voltage Battery current
Bank 2	Battery voltage State of charge
Bank 3	Battery voltage State of charge

HISTORY

Settings	Variables
History	Since startup Since alarm Since full Cycles count Battery low Calculated CEF Total consumed Avg. discharge
Min/Max history	Bank 1 deepest (Ah) Bank 1 deepest (V) Bank 1 lowest (V) Bank 1 highest (V)

Min/Max history	Bank 2 lowest (V) Bank 2 highest (V) Bank 3 lowest (V) Bank 3 highest (V)
-----------------	--

CONFIGURATION

Settings	Variables
General	Language Name bank 1 Name bank 2 Name bank 3 No shunt Energy save
Bank 1	Nominal voltage Battery capacity Average load Charge current Alarm Low voltage High voltage Low delay Battery empty Battery full Min. run time Max. run time
Bank 2	Nominal voltage Battery capacity Average load Charge current Alarm Low voltage High voltage Low delay Battery empty Battery full Min. run time Max. run time
Bank 3	Nominal voltage Battery capacity Average load Charge current Alarm Low voltage High voltage Low delay Battery empty Battery full Min. run time Max. run time
Advanced	Bank 1 CEF Bank 1 Peukert Bank 1 reset Return amp. Float Bank 2 CEF Bank 2 Peukert Bank 2 reset Bank 3 CEF Bank 3 Peukert Bank 3 reset Reset to factory

5 ORDERING INFORMATION

Part number	Description
77040000*	MasterBus terminating device*
77040020	MasterBus connection cable (UTP patch cable), 0,2m / 0.6ft
77040050	MasterBus connection cable (UTP patch cable), 0,5m / 1.6ft
77040100	MasterBus connection cable (UTP patch cable), 1,0m / 3.3ft
77040300	MasterBus connection cable (UTP patch cable), 3,0m / 10ft
77040600*	MasterBus connection cable (UTP patch cable), 6,0m / 20ft*
77041000	MasterBus connection cable (UTP patch cable), 10m / 33ft
77041500	MasterBus connection cable (UTP patch cable), 15m / 49ft
77042500	MasterBus connection cable (UTP patch cable), 25m / 82ft
77050000	Complete set to assemble UTP patch cables. Delivery includes: 100m / 330ft UTP cable, 50 pcs. modular jacks and crimping tool
6502001030	Serial connection cables RS 232-cross wired, 6m
6502100100	Serial connection cables RS 232-cross wired, 10m
6502100150	Serial connection cables RS 232-cross wired, 15m
6502100200	Serial connection cables RS 232-cross wired, 20m
6502100250	Serial connection cables RS 232-cross wired, 25m

* These parts are standard included with the delivery of the *MasterBus - Serial interface*

Mastervolt can offer a wide range of products for your electrical installation, including an extended program of components for your MasterBus network or MasterVision switchboard. See our website www.mastervolt.com for a complete overview of all our products

6 TROUBLE SHOOTING

Contact your local Mastervolt Service Centre if you cannot correct a problem with the aid of the malfunction table below. See www.mastervolt.com for an extended list of Mastervolt Service Centres.

Failure	Possible cause	What to do
No MasterBus activity is present.	There is no MasterBus powering device connected or switched on.	Connect and/ or switch on the MasterBus powering device (like the MasterShunt).
The green LED on the interface is not illuminated or blinking.	The MasterBus - Serial interface has not been connected to the serial port.	Check serial cable and connections between the MasterBus – Serial interface and the serial port.
	The MasterBus - Serial interface has not been connected to the MasterBus port.	Check MasterBus cables and connections.
The connected device cannot be found.	Connected device is switched off.	Switch on connected device
	Error in the wiring.	Check the serial cables. You need Cross wired serial cables (1 to 6), no MasterBus cables.
	Wrong connections. The MasterBus cable shall not be linked to a non-MasterBus connector like RS232. And the serial cable shall not be linked to the MasterBus connector.	Check the connections.
No communication between the connected device and the MasterBus network.	If a setting of the connected device has been changed, communication between the MasterBus network and the connected device may take a few seconds.	Wait for a few seconds.
	Error in the wiring.	Check the MasterBus cables and serial cable. You need Cross wired (1 to 6) serial cables (no Straight wired cables and no MasterBus cables).
	No terminating device placed at the ends of the network.	Check if terminating devices are installed on both ends of the MasterBus network (see manual of the MasterBus powering device).
	MasterBus network is configured as a ring network.	Ring networks are not allowed (see manual of the MasterBus powering device). Check the connections of the network.

Failure	Possible cause	What to do
	T-connections in the MasterBus network.	Check if there are no T-connections in the network. T-connections are not allowed (see manual of the MasterBus powering device).
Wrong language is displayed.	Wrong setting of the language at the Serial Interface.	Click on the "Language" menu and select the desired language.
	Wrong setting of the language at the MasterBus display.	Each separate connected device can have its own language setting, including the display. See user's manual of the display.

7 TECHNICAL INFORMATION

7.1 SPECIFICATIONS

Model:	MasterBus – Serial interface
Article number:	77030450
Delivery includes:	Interface, Serial connection cable, MasterBus cable, MasterBus terminating device, user's manual
Function of instrument:	Communication interface between a Mastervolt serial bus device and the MasterBus network.
Compatible with:	Mass Combi, Mass Charger, MAC/ MAGIC
Manufacturer:	Mastervolt Amsterdam, the Netherlands
MasterBus Powering capabilities:	No
Power consumption:	144 mW
Weight	Approx. 80 gr
Protection degree:	IP 21
Dimensions:	66 x 78 x 32 mm; see drawing below

7.2 DIMENSIONS AND CONNECTIONS

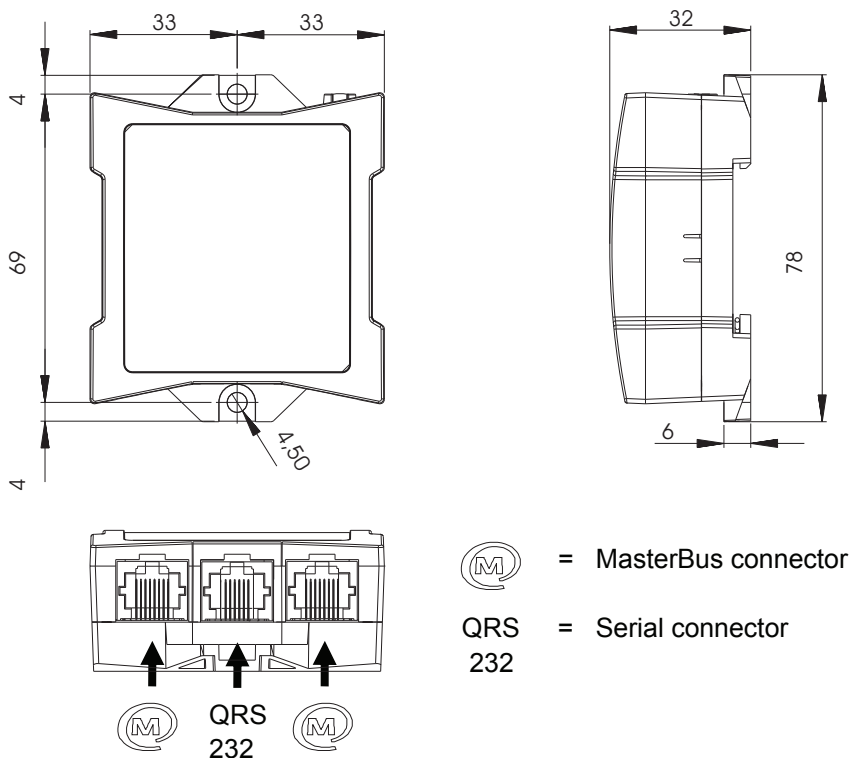

Figure 2

8 EC DECLARATION OF CONFORMITY

Manufacturer Mastervolt
Address Snijdersbergweg 93, 1105 AN Amsterdam
The Netherlands



Herewith declares that:

Product:
77030450 MasterBus – Serial Interface

Is in conformity with the provision of the EC EMC directive 89/336/EEC and amendments 92/31/EEC, 93/68/EEC.

The following harmonised standards have been applied:

Generic emission standard: EN 50081-1:1992
Generic Immunity standard: EN 50082-1:1997

Safety directive 2006/95/EC, with the following standard:
Low voltage standard: EN 60950: 2000

Amsterdam,

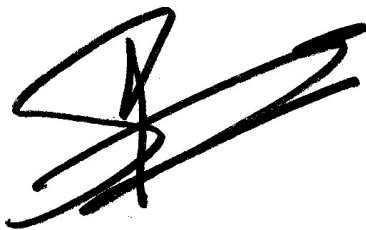

P. F. Kenninck,
General Manager MASTERVOLT