

REPEAT 3100

Installation and Operation Manual

English	2
Français	15
Español	27
Português	39



FCC Statement

Note: This equipment has been tested and found to comply with the limits for a Class B digital device, pursuant to Part 15 of the FCC Rules. These limits are designed to provide reasonable protection against harmful interference in a normal installation. This equipment generates, uses and can radiate radio frequency energy and, if not installed and used in accordance with the instructions, may cause harmful interference to radio communications. However, there is no guarantee that interference will not occur in a particular installation. If this equipment does cause harmful interference to radio or television reception, which can be determined by turning the equipment off and on, the user is encouraged to try to correct the interference by one or more of the following measures:

- Reorient or relocate the receiving antenna.
- Increase the separation between the equipment and receiver.
- Connect the equipment into an output on a circuit different from that to which the receiver is connected.
- Consult the dealer or an experienced technician for help.
- A shielded cable must be used when connecting a peripheral to the serial ports.

Contents

1 Introduction	4
2 Operation	5
2-1 Turning on and off	5
2-2 The keys and backlight	5
2-3 Changing the data displayed	5
2-4 Changing units	6
2-5 Simulate	6
2-6 Key reference	6
3 Systems of several instruments	7
3-1 NavBus	7
3-2 NMEA	7
4 REPEAT 3100 hardware	7
4-1 What comes with a REPEAT 3100	7
4-2 Other parts required	7
4-3 Accessories	7
5 Installation and setup	8
5-1 Installation	8
5-2 Setup	10
5-3 Resetting to factory defaults	10
Appendix A - Specifications	11
Appendix B - NMEA function table	12
Appendix C - Troubleshooting	14
Appendix D - How to contact us	51

Important

It is the owner's sole responsibility to install and use the instrument in a manner that will not cause accidents, personal injury or property damage. The user of this product is solely responsible for observing safe boating practices.

NAVMAN NZ LIMITED DISCLAIMS ALL LIABILITY FOR ANY USE OF THIS PRODUCT IN A WAY THAT MAY CAUSE ACCIDENTS, DAMAGE OR THAT MAY VIOLATE THE LAW.

This manual represents the REPEAT 3100 as at the time of printing. Navman NZ Limited reserves the right to make changes to specifications without notice.

Governing Language: This statement, any instruction manuals, user guides and other information relating to the product (Documentation) may be translated to, or has been translated from, another language (Translation). In the event of any conflict between any Translation of the Documentation, the English language version of the Documentation will be the official version of the Documentation.

Copyright © 2002 Navman NZ Limited, New Zealand. All rights reserved. NAVMAN is a registered trademark of Navman NZ Limited.

1 Introduction

The REPEAT 3100 is part of the NAVMAN 3100 series of instruments, which measure speed, depth, wind, water temperature, battery voltage and other functions. The REPEAT 3100 can display any data that is output from 3100 series instruments, as well as NMEA data from compatible instruments. The REPEAT 3100 can also act as a GPS repeater and provides a wealth of information on deck from a GPS situated in a more protected position, such as below decks.

The REPEAT 3100 can obtain its data in two ways:

- From other 3100 Series instruments which are connected by NavBus (NavBus is NAVMAN's

proprietary system for connecting marine instruments).

- From a maximum of three instruments, such as NAVMAN's TRACKER Chartplotters, that send compatible NMEA 0183 V2 data. When connecting the REPEAT 3100 to 3rd party instruments, ensure that the NMEA data being sent is compatible.

For maximum benefit, please read this manual carefully before installation and use.

Cleaning and maintenance

Clean the unit with a damp cloth or mild detergent. Avoid abrasive cleaners, petrol or other solvents.

The REPEAT 3100 display unit



Display modes (see section 2-3)



Dual mode: two items of data from SPEED 3100, DEPTH 3100 or MULTI 3100

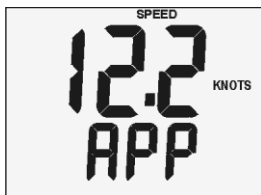

Wind mode: one item of data from WIND 3100



NMEA mode: one item of data from compatible NMEA instruments

2 Operation

2-1 Turning on and off

Turn the unit on and off with the auxiliary power switch on the boat. The unit does not have its own power switch. When you turn the unit off, it retains any settings.

If the word SIM flashes at the bottom, right of the display, then simulate is on (see section 2-5).

2-2 The keys and backlight

The unit has four keys, labelled **+**, **Q**, **∇** and **∧**. In this manual:

- **Press** means to push the key for less than one second.
- **Hold** for two seconds means to hold the key down for two seconds or more.
- **Press one key + another key** means to push both keys together.

Set backlight for screen and keys

You can set the backlight to one of four brightness levels or off. Press **Q** once to display the current backlight level, press **Q** again to change the level:



Backlight level 2

2-3 Changing the data displayed

The display has three modes:

- **Dual mode** displays speed or depth data.
- **Wind mode** displays wind data.
- **NMEA mode** displays data from compatible NMEA instruments.

To change mode, press **+** one or more times.

Note: If the display is dashes (— —) then it means that the data is not available or the instrument which sends the data to the REPEAT 3100 is turned off or disconnected.

Dual mode



Dual Mode displays two items of data at a time from a SPEED 3100, DEPTH 3100 or MULTI 3100. To change the item displayed in the top line of the display, press **∧** one or more times. The choices are:

- Speed.
- Avg speed.
- Max speed.
- Trim speed.
- Depth.
- Temperature.

To change the item displayed in the bottom line of the display, press **∇** one or more times. The choices are:

- Speed.
- Depth.
- Trip log (distance).
- Total log (distance).
- Battery voltage.
- Countdown timer.

Wind mode

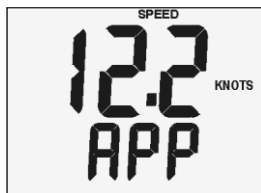

Wind mode displays one item of data at a time from a WIND 3100. To change the item displayed, press **∇** or **∧** one or more times. The choices are:

- Apparent wind direction.
- True wind direction.
- Apparent wind speed.
- True wind speed.
- Max wind speed.
- VMG.

NMEA mode



NMEA Mode displays one item of data at a time from any compatible NMEA instrument. To select which NMEA data can be displayed, see section 5-2, step 2. To change the item displayed, press **∨** or **∧** one or more times.

2-4 Changing units

To change the units on the REPEAT 3100, change the units on the instrument which sends the data to the REPEAT 3100.

2-5 Simulate

Simulate allows you to become familiar with the REPEAT 3100 off the water. When simulate is on, the unit functions normally except that the data from other instruments is ignored and the unit generates this data internally. The word SIM flashes at the bottom, right corner of the screen if:

- The REPEAT 3100 has simulate on.
- Any instrument connected to the REPEAT 3100 by the NavBus has simulate on.

To turn simulate on or off in the REPEAT 3100:

- 1 Turn the power off.
- 2 Hold down **+** while you turn the power on.

2-6 Key reference

Turn power on

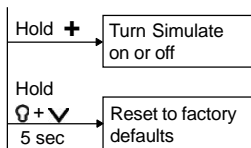

Normal operation

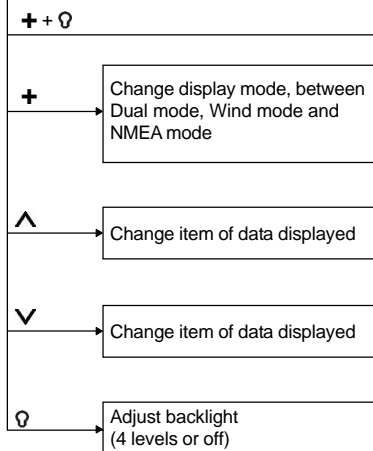

Setup

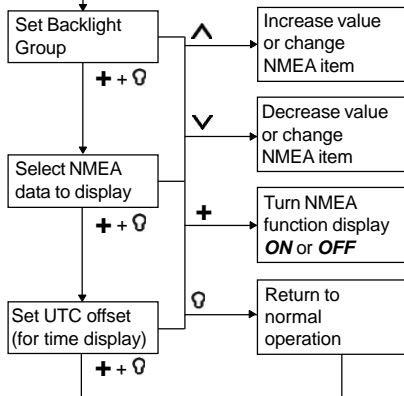

3 Systems of several instruments



Several NAVMAN instruments can be connected together to share data. There are two ways of connecting instruments together, NavBus or NMEA.

3-1 NavBus

NavBus is a NAVMAN proprietary system that allows systems of multiple instruments to be built using a single set of transducers. When instruments are connected by NavBus:

- If you change the units, alarms or calibration in one instrument, then the values will automatically change in all other instruments of the same type.
- Each instrument can be assigned to a group of instruments (see section 5-2, step 2). If you change the backlight in an instrument in group 1, 2, 3 or 4 then the backlight will automatically change in the other instruments in the same

group. If you change the backlight in an instrument in group 0 then no other instruments are affected.

- If an alarm sounds, mute it by pressing  on any NAVMAN instrument which can display that alarm and which has a  key. Alarms can not be muted from a REPEAT 3100.

NavBus and the REPEAT 3100

- The REPEAT 3100 will automatically read and display data from other instruments connected by NavBus.

3-2 NMEA

NMEA is an industry standard, but is not as flexible as NavBus as it requires dedicated connections between compatible instruments. The REPEAT 3100 can read and display NMEA data output by up to three instruments (see Appendix B).

4 REPEAT 3100 hardware

4-1 What comes with a REPEAT 3100

- REPEAT 3100 unit with protective cover.
- Warranty card.
- Mounting template.
- This Installation and Operation manual.

4-2 Other parts required

One or more 3100 series instruments will be connected to the boat 12 V power supply via:

- An accessory switch to turn the instruments on and off.
- A fuse: Use a 1 A fuse for between one and five instruments.

The REPEAT 3100 can receive and display:

- Data from other NAVMAN instruments connected via NavBus; settings for units and backlighting are shared (see section 3-1).
- NMEA data from up to three compatible instruments (see section 3-2).

Wiring and connectors are required (see section 5 or the NavBus Installation and Operation manual).

4-3 Accessories

NavBus junction boxes are available from your NAVMAN dealer.



5 Installation and setup

Correct installation is critical to the performance of the unit. It is vital to read this section of the manual and the documentation that comes with the other parts before starting installation.

Warnings

The unit is waterproof from the front. Protect the rear of the unit from water, or else water might enter the

breathing hole and damage the unit. The warranty does not cover damage caused by moisture or water entering the back of the unit.

Ensure that any holes that you cut will not weaken the boat's structure. If in doubt, consult a qualified boat builder.

5-1 Installation

REPEAT 3100 display unit

- 1 Choose a location for the display unit that is:
 - Easily seen and protected from damage.
 - At least 100 mm (4") from a compass and at least 500 mm (1.65 ft) from a radio or radar antenna.
 - Away from engines, fluorescent lights, and power inverters.
 - Accessible from behind; the minimum clearance required at the back is 50 mm (2") (see right).
 - With the back of the unit protected from moisture.
- 2 The unit must mount on a flat panel which is less than 20 mm (0.75") thick. Stick the mounting template in place. Drill a 50 mm (2") fixing hole through the centre hole in the template.

Note that the template allows space around the unit for the protective cover.

- 3 Remove the fixing nut from the back of the unit. Insert the stud at the back of the unit through the mounting hole. Hand tighten the fixing nut.

Power/data cable wiring

Follow the wiring example on the next page:

- 1 The REPEAT 3100 requires 12 V DC power. Fit a power switch and fuse to the power supply or power the unit from a fused auxiliary switch. The fuse should be 1 A for up to five NAVMAN 3100 series instruments.
- 2 If the REPEAT 3100 is to receive data from other instruments via the NavBus, install these instruments and connect the REPEAT 3100 to the NavBus.

Note: If an instrument can be connected to the REPEAT 3100 by both NavBus and by NMEA, then use the NavBus, because more information can be shared via the NavBus (see section 3-1).

Side view of display unit mounting

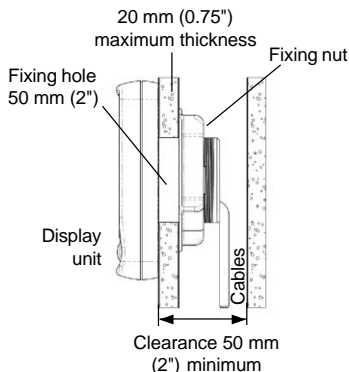

- 3 If the REPEAT 3100 is to receive NMEA data from other compatible instruments, install these instruments and connect each instrument's NMEA output to one of the three REPEAT 3100 NMEA inputs. Up to three instruments can be connected.
- 4 Tape or cover any unused wires or connectors to protect them from water and keep them from shorting together.

Setup and test

Set up the unit as described in section 5-2.

Take the boat for a trial run to check that all the instruments work correctly.

REPEAT 3100 wiring example

In this example, the REPEAT 3100 receives data from a NAVMAN WIND 3100 and a SPEED 3100 via the NavBus. Any number of NAVMAN instruments can be connected to the NavBus and send data to the REPEAT 3100.

The REPEAT 3100 also receives NMEA data from a GPS and a compass. One more NMEA instrument could be connected to the third NMEA input on the REPEAT 3100.

Wire any more REPEAT 3100s in parallel with the first.

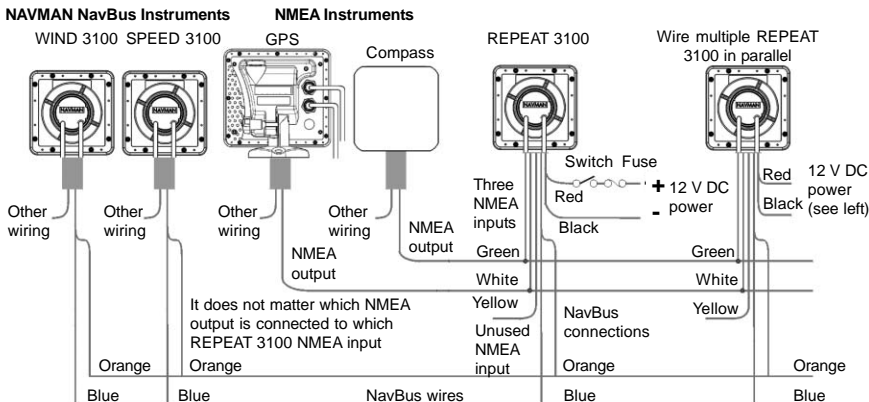

Use optional junction boxes to simplify wiring, (see right). For information on how to connect NavBus and to use junction boxes, refer to the NavBus Installation and Operation manual.

Tip: Daisychain the power wires between instruments or groups of instruments.

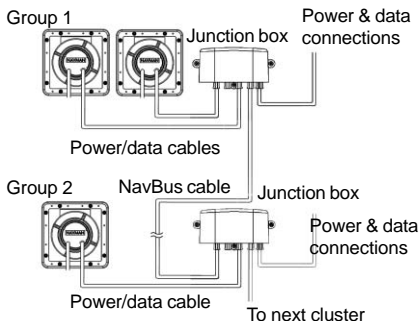

5-2 Setup

- 1 If the unit is part of a system of 3100 series instruments connected by NavBus, set the backlight group number (see section 3-1):

- i Press **+** + **Q** to display the Backlight Group screen:



Backlight group 2

- ii Press **^** or **v** to set the backlight group number.

- 2 If the unit is to display data sent by NMEA, select what NMEA data items will be displayed (see section 2-3, NMEA mode):

- i Ensure that all the instruments which send NMEA data to the REPEAT 3100 are turned on and are transmitting the NMEA data.
- ii Press **+** + **Q** until the NMEA Selection



NMEA function number

Function can be **ON** or **OFF**

NMEA input number, identifies which wire the NMEA data is received on (see Appendix A, Power/data cable wires)

- screen is displayed:
- iii If a NMEA instrument has recently been connected to or disconnected from the REPEAT 3100, press **Q** + **v** to clear the detected NMEA strings.
- iv The REPEAT 3100 automatically detects NMEA data sentences from the NMEA instruments which are sending data and displays them here.

Press **^** or **v** to show each NMEA function in turn, note that the data value itself is not displayed.

For each function, use the NMEA function number to look up the data description in

the NMEA function table (see appendix B). Then press **+** if necessary to turn the function **ON** (data will be displayed) or **OFF** (data will not be displayed).

- 3 If the unit is to display local time, set the UTC offset. The UTC offset will be added to the UTC (GMT) time sent from a GPS instrument to display the local time. To set the UTC offset:
 - i Press **+** + **Q** until the UTC Offset screen is displayed:



Offset is + 2.5 hours

- ii Press **^** or **v** to set the UTC offset. The range is +13 to -13 hours in 0.5 hour increments.

Note: Daylight saving time must be adjusted manually.

- 4 Press **Q** to return to normal operation.

5-3 Resetting to factory defaults

All settings may be reset to the manufacturer's default settings (see below).

To reset to factory defaults:

- 1 Turn the power off.
- 2 Hold down **Q** + **v** while you turn the power on and continue to hold the keys down for at least 5 seconds.

SIMULATE mode	OFF
Backlight level	0
Backlight group	1
NMEA data to display	All are OFF
UTC offset	0 hours

Appendix A - Specifications

Physical

- Case size 111 mm (4.4") square.
- LCD display 82 mm (3.2") wide, 61 mm (2.4") high; twisted nematic.
- LCD digits 30 mm (1.2") high on top line, 20 mm (0.8") high on bottom line.
- Four operator keys, laser etched.
- Backlighting for display and keys, amber, four levels and off.
- Operating temperature 0 to 50°C (32 to 122°F).
- Power cable length 1 m (3.25 ft).

Electrical

- Power supply 10.5 to 16.5 V DC, 20 mA without backlighting, 60 mA with full backlighting.

NavBus interface and display

- NavBus interface for NAVMAN SPEED 3100, DEPTH 3100, MULTI 3100 and/or WIND 3100 instruments.

Can receive and display these values from the NavBus:

- Current speed, average speed, maximum speed, trim speed.
- Log: trip log and total log.
- Temperature.
- Countdown timer (from SPEED 3100 or MULTI 3100).
- Depth.
- Wind speed and direction (true and apparent).
- VMG.

NMEA interface and display

- Three NMEA 0183 inputs for compatible NMEA instruments.

Can receive and display these NMEA sentences:

APB, BEC, BOD, BWC, BWR, BWR, DBT, DPT, GGA, GNS, HDG, HDT, HSC, MTW, MWD, MWV, RMA, RMB, RMC, VDR, VHW, VLW, VPW, VTG, WCV, XTE, XTR, ZDA (see Appendix B).

Standards compliance

- EMC compliance:
 - **USA** (FCC): Part 15 Class B.
 - **Europe** (CE): EN50081-1, EN50082-1.
 - **New Zealand and Australia** (C Tick): AS-NZS 3548.
- Environment: IP66 from front when correctly mounted.

Power/data cable wires

Wire	Signal
Red	Power positive, 12 V DC
Black	Power negative, NMEA common
Orange	NavBus +
Blue	NavBus -
White	NMEA input 1
Yellow	NMEA input 2
Green	NMEA input 3

Appendix B - NMEA function table

Item No.	Function	Units	NMEA sentence
110	Depth	Meters	DPT
120	Depth	Feet	DBT
130	Depth	Meters	DBT
140	Depth	Fathoms	DBT
150	Boat Speed	Knots	VHW
160	Boat Speed	Kph	VHW
170	Trip Distance	Nautical Miles	VLW
180	Total Distance	Nautical Miles	VLW
190	Water Temperature	Degrees Celsius	MTW
200	Wind Speed	Units specified in sentence (True or Apparent and Kph, m/s, or Knots)	MWV
210	Wind Speed	True, Knots	MWD
220	Wind Speed	True, m/s	MWD
230	Wind Direction	Dir type specified in sentence (True or Apparent)	MWV
240	Magnetic Wind Direction	Degrees	MWD
250	Speed Parallel to Wind	Knots	VPW
260	Speed Parallel to Wind	m/s	VPW
270	Current Set	Degrees True	VDR
280	Current Set	Degrees Magnetic	VDR
290	Current Drift	Knots	VDR
300	Heading	Degrees True	VHW
310	Heading	Degrees Magnetic	VHW
320	Heading	Degrees True	HDG
330	Heading	Degrees Magnetic	HDG
340	Heading	Degrees True	HDT
350	Position	Degrees, Minutes	GGA
360	Position	Degrees, Minutes	GNS
370	Position	Degrees, Minutes	RMA
380	Position	Degrees, Minutes	RMC
390	Speed Over Ground (SOG)	Knots	RMA
400	Speed Over Ground (SOG)	Knots	RMC
410	Speed Over Ground (SOG)	Knots	VTG
420	Speed Over Ground (SOG)	Kph	VTG
430	Course Over Ground (COG)	Degrees True	RMA
440	Course Over Ground (COG)	Degrees Magnetic	RMA
450	Course Over Ground (COG)	Degrees True	RMC
460	Course Over Ground (COG)	Degrees Magnetic	RMC
470	Course Over Ground (COG)	Degrees True	VTG
480	Course Over Ground (COG)	Degrees Magnetic	VTG
490	Bearing To Waypoint (BTW)	Type specified in sentence (True or Magnetic)	APB
500	Bearing To Waypoint (BTW)	Degrees True	BEC
510	Bearing To Waypoint (BTW)	Degrees Magnetic	BEC
520	Bearing To Waypoint (BTW)	Degrees True	BWC
530	Bearing To Waypoint (BTW)	Degrees Magnetic	BWC
540	Bearing To Waypoint (BTW)	Degrees True	BWR
550	Bearing To Waypoint (BTW)	Degrees Magnetic	BWR
560	Bearing To Waypoint (BTW)	Degrees True	RMB
570	Distance To Waypoint (DTW)	Nautical Miles	BEC
580	Distance To Waypoint (DTW)	Nautical Miles	BWC
590	Distance To Waypoint (DTW)	Nautical Miles	BWR
600	Distance To Waypoint (DTW)	Nautical Miles	RMB

Item No.	Function	Units	NMEA sentence
610	Heading To Steer (HTS)	Type specified in sentence (True or Magnetic)	APB
620	Heading To Steer (HTS)	Degrees True	HSC
630	Heading To Steer (HTS)	Degrees Magnetic	HSC
640	Cross Track Error (CTE)	Nautical Miles	APB
650	Cross Track Error (CTE)	Nautical Miles	RMB
660	Cross Track Error (CTE)	Nautical Miles	XTE
670	Cross Track Error (CTE)	Nautical Miles	XTR
680	Waypoint Closure Velocity (WCV)	Knots	RMB
690	Waypoint Closure Velocity (WCV)	Knots	WCV
700	Bearing, Origin to Destination (BOD)	Type specified in sentence (True or Magnetic)	APB
710	Bearing, Origin to Destination (BOD)	Degrees True	BOD
720	Bearing, Origin to Destination (BOD)	Degrees Magnetic	BOD
730	Time	Without Seconds	RMC
740	Time	Without Seconds	ZDA
750	Time	With Seconds	RMC
760	Time	With Seconds	ZDA
770	Date	mm.dd.yyyy	RMC
780	Date	mm.dd.yyyy	ZDA

Appendix C - Troubleshooting

This troubleshooting guide assumes that you have read and understood this manual.

It is possible in many cases to solve difficulties without having to send the unit back to the manufacturer for repair. Please follow this troubleshooting section before contacting the nearest NAVMAN dealer.

There are no user serviceable parts. Specialized methods and testing equipment are required to ensure that the unit is reassembled correctly and is waterproof. Repairs to the unit must only be carried out by a service centre approved by Navman NZ Limited. Users who service the unit themselves will void the warranty.

More information can be found on our website: www.navman.com

- 1 Unit will not turn on:**
 - a Fuse blown or circuit breaker tripped.
 - b Power supply voltage is outside the range 10.5 to 16.5 V DC.
 - c Power/data cable damaged.
- 2 Displays dashes (— —) instead of a data value:**
 - a The REPEAT 3100 has not been installed with an instrument that can send compatible data to the REPEAT 3100.
 - b The instrument that sends compatible data to the REPEAT 3100 is turned off or the value is outside the range that the instrument can display.
 - c Power/data cable damaged.
- 3 Values displayed are wrong or erratic:**
 - a The instrument that sends compatible data to the REPEAT 3100 is not operating correctly. Refer to the troubleshooting guide in the instrument's installation and operation manual.
 - b Interference from electrical noise. Review installation.
- 4 Unit operates erratically or unexpectedly:**

Unit set up incorrectly. Reset to factory defaults (see section 5-3). Then setup the unit again (see section 5-2).
- 5 Unit will only display one item of wind or NMEA data at a time:**

This is normal. Two items are only displayed in dual mode.
- 6 An item of NMEA data is not displayed:**

Turn the NMEA function on (see section 5-2, step 2).
- 7 A NMEA function is not displayed in the NMEA selection screen (see section 5-2, step 2):**

Press **▲** or **▼** to scroll through the available functions. If a function is not displayed then it means that the REPEAT 3100 is not connected to a compatible NMEA instrument that outputs that NMEA sentence.
- 8 The word SIM flashes at bottom, right of screen, values displayed are unexpected:**
 - a The REPEAT 3100 has simulate turned on (see section 2-5).
 - b An instrument sending data to the REPEAT 3100 has simulate turned on (see section 2-5).
- 9 The display fogs:**
 - a Moist air has entered the breathing tube at the rear of the unit. Air the boat or run unit with backlight fully on.
 - b Water has entered the breathing tube. Return unit for service.

NORTH AMERICA**NAVMAN USA INC.**

18 Pine St. Ext.
Nashua, NH 03060.
Ph: +1 603 577 9600
Fax: +1 603 577 4577
e-mail: sales@navmanusa.com

OCEANIA**New Zealand**

Absolute Marine Ltd.
Unit B, 138 Harris Road,
East Tamaki, Auckland.
Ph: +64 9 273 9273
Fax: +64 9 273 9099
e-mail:
navman@absolutemarine.co.nz

Australia**NAVMAN AUSTRALIA PTY
Limited**

Unit 6 / 5-13 Parsons St,
Rozelle, NSW 2039, Australia.
Ph: +61 2 9818 8382
Fax: +61 2 9818 8386
e-mail: sales@navman.com.au

SOUTH AMERICA**Argentina**

HERBY Marina S.A.
Costanera UNO,
Av Pte Castillo Calle 13
1425 Buenos Aires, Argentina.
Ph: +54 11 4312 4545
Fax: +54 11 4312 5258
e-mail:
herbymarina@ciudad.com.ar

Brazil**REALMARINE**

Estrada do Joa 3862,
CEP2611-020,
Barra da Tijuca, Rio de Janeiro,
Brasil.
Ph: +55 21 2483 9700
Fax: +55 21 2495 6823
e-mail:
vendas@marinedepot.com.br

**Equinautic Com Imp Exp de
Equip Nauticos Ltda.**

Av. Diario de Noticias 1997 CEP
90810-080, Bairro Cristal, Porto
Alegre - RS, Brasil.
Ph: +55 51 3242 9972
Fax: +55 51 3241 1134
e-mail:
equinautic@equinautic.com.br

ASIA**China**

Peaceful Marine Electronics Co. Ltd.
Hong Kong, Guangzhou,
Shanghai, Qindao, Dalian.
E210, Huang Hua Gang Ke Mao
Street, 81 Xian Lie Zhong Road,
510070 Guangzhou, China.
Ph: +86 20 3869 8784
Fax: +86 20 3869 8780
e-mail:
sales@peaceful-marine.com
Website:
www.peaceful-marine.com

Korea

Kumho Marine Technology Co. Ltd.
604-816, 3F, 1117-34,
Koejung4-Dong, Saha-ku
Pusan, Korea
Ph: +82 51 293 8589
Fax: +82 51 294 0341
e-mail: info@kumhomarine.com
Website:
www.kumhomarine.com

Malaysia

Advanced Equipment Co.
43A, Jalan Jejaka 2, Taman
Maluri, Cheras 55100, Kuala Lumpur.
Ph: +60 3 9285 8062
Fax: +60 3 9285 0162
e-mail: ocs@pc.jaring.my

Singapore

RIQ PTE Ltd.
Block 3007, Ubi Road 1
#02-440, Singapore 408701
Ph: +65 6741 3723
Fax: +65 6741 3746
HP: +65 9679 5903
e-mail: riq@postone.com

Thailand

Thong Electronics (Thailand)
Company Ltd.
923/588 Thaprong Road,
Mahachai,
Muang, Samutsakhon 74000,
Thailand.
Ph: +66 34 411 919
Fax: +66 34 422 919
e-mail: thonge@cscoms.com

Vietnam

Haidang Co. Ltd.
16A/ALE, Ba thang hai St.
District 10, Hochiminh City.
Ph: +84 8 86321 59
Fax: +84 8 86321 59
e-mail:
sales@haidangvn.com
Website: www.haidangvn.com

MIDDLE EAST**Lebanon and Syria**

Letro, Balco Stores
Moutran Street, Tripoli
VIA Beirut.
Ph: +961 6 624512
Fax: +961 6 628211
e-mail: balco@cyberia.net.lb
United Arab Emirates
Kuwait, Oman & Saudi Arabia
AMIT, opp Creak Rd.
Baniyas Road, Dubai.
Ph: +971 4 229 1195
Fax: +971 4 229 1198
e-mail: mksq99@email.com

AFRICA**South Africa**

Pertec (Pty) Ltd Coastal,
Division No.16 Paarden Eiland Rd.
Paarden Eiland, 7405
Postal Address: PO Box 527,
Paarden Eiland 7420
Cape Town, South Africa.
Ph: +27 21 511 5055
Fax: +27 21 511 5022
e-mail: info@kfa.co.za

EUROPE**France, Belgium and****Switzerland**

PLASTIMO INTERNATIONAL
15, rue Ingénieur Verrière,
BP435,
56325 Lorient Cedex.
Ph: +33 2 97 87 36 36
Fax: +33 2 97 87 36 49
e-mail: plastimo@plastimo.fr
Website: www.plastimo.fr

Germany**PLASTIMO DEUTSCHLAND**

15, rue Ingénieur Verrière
BP435
56325 Lorient Cedex.
Ph: +49 6105 92 10 09
+49 6105 92 10 10
+49 6105 92 10 12
Fax: +49 6105 92 10 11

e-mail:

plastimo.international@plastimo.fr
Website: www.plastimo.de

Italy**PLASTIMO ITALIA**

Nuova Rade spa, Via del Pontasso 5
I-16015 CASELLA SCRIVIA (GE).
Ph: +39 1096 8011
Fax: +39 1096 8015
e-mail: info@nuovarade.com
Website: www.plastimo.it

Holland

PLASTIMO HOLLAND BV.
Industrieweg 4-6,
2871 RP SCHOONHOVEN.
Ph: +31 182 320 522
Fax: +31 182 320 519
e-mail: info@plastimo.nl
Website: www.plastimo.nl

United Kingdom

PLASTIMO Mfg. UK Ltd.
School Lane - Chandlers Ford
Industrial Estate,
EASTLEIGH - HANTS SO53 ADG.
Ph: +44 23 8026 3311
Fax: +44 23 8026 6328
e-mail: sales@plastimo.co.uk
Website: www.plastimo.co.uk

Sweden, Denmark or Finland

PLASTIMO NORDIC AB.
Box 28 - Lundenvägen 2,
47321 HENAN.
Ph: +46 304 360 60
Fax: +46 304 307 43
e-mail: info@plastimo.se
Website: www.plastimo.se

Spain

PLASTIMO ESPAÑA, S.A.
Avenida Narcís Monturiol, 17
08339 VILASSAR DE DALT,
(Barcelona).
Ph: +34 93 750 75 04
Fax: +34 93 750 75 34
e-mail: plastimo@plastimo.es
Website: www.plastimo.es

Other countries in Europe

PLASTIMO INTERNATIONAL
15, rue Ingénieur Verrière
BP435
56325 Lorient Cedex, France.
Ph: +33 2 97 87 36 59
Fax: +33 2 97 87 36 29
e-mail:
plastimo.international@plastimo.fr
Website: www.plastimo.com

REST OF WORLD /**MANUFACTURERS**

NAVMAN NZ Limited
13-17 Kawana St. Northcote.
P.O. Box 68 155 Newton,
Auckland, New Zealand.
Ph: +64 9 481 0500
Fax: +64 9 480 3176
e-mail:
marine.sales@navman.com
Website:
www.navman.com

Made in New Zealand
MN000135B

Lon.174° 44.535'E

Lat 36° 48.404'S



REPEAT 3100

NAVMAN

FC  CE