



Explorer 457/467





Fishfinder

Installation and Operation Manual

NORTHSTAR★

www.northstarnav.com

IMPORTANT SAFETY INFORMATION
Please read carefully before installation and use.

	This is the safety alert symbol. It is used to alert you to potential personal injury hazards, Obey all safety messages that follow this symbol to avoid possible injury or death.
	WARNING indicates a potentially hazardous situation which, if not avoided, could result in death or serious injury
	CAUTION indicates a potentially hazardous situation which, if not avoided, could result in minor or moderate injury.
	CAUTION used without the safety alert symbol indicates a potentially hazardous situation which, if not avoided, may result in property damage.

DISCLAIMER: It is the owner's sole responsibility to install and use the instrument and transducers in a manner that will not cause accidents, personal injury or property damage. The user of this product is solely responsible for observing safe boating practices.

BRUNSWICK NEW TECHNOLOGIES INC. AND ITS SUBSIDIARIES AND AFFILIATES DISCLAIM ALL LIABILITY FOR ANY USE OF THIS PRODUCT IN A WAY THAT MAY CAUSE ACCIDENTS, DAMAGE OR THAT MAY VIOLATE THE LAW.

Governing Language: This statement, any instruction manuals, user guides and other information relating to the product (Documentation) may be translated to, or

has been translated from, another language (Translation). In the event of any conflict between any Translation of the Documentation, the English language version of the Documentation will be the official version of the Documentation.

This manual represents the Explorer 457/467 as at the time of printing. Brunswick New Technologies Inc. and its subsidiaries and affiliates reserve the right to make changes to specifications without notice.

Copyright © 2006 Brunswick New Technologies Inc. Northstar™ is a registered trademark of Brunswick New Technologies Inc

FCC Statement

Note: This equipment has been tested and found to comply with the limits for a Class B digital device, pursuant to Part 15 of the FCC Rules. These limits are designed to provide reasonable protection against harmful interference in a normal installation. This equipment generates, uses and can radiate radio frequency energy and, if not installed and used in accordance with the instructions, may cause harmful interference to radio communications. However, there is no guarantee that interference will not occur in a particular installation. If this equipment does cause harmful interference to radio or television reception, which can be determined by turning the equipment off and on, the user is encouraged to try to correct the interference by one or more of the following measures:

- Reorient or relocate the receiving antenna.
- Increase the separation between the equipment and receiver.
- Connect the equipment into an output on a circuit different from that to which the receiver is connected.
- Consult the dealer or an experienced technician for help.
- A shielded cable must be used when connecting a peripheral to the serial ports.

Important

The choice, location, angle and installation of the instrument & transducers are critical to performance of the system as intended. Follow instructions in this manual carefully. If in doubt, consult your Northstar dealer.

Ensure that any holes cut are in a safe position and will not weaken the boat's structure. If in doubt, consult a qualified boat builder.

Do not install plastic through hull transducers in solid wooden hulls. Leaking through the hull may result.

Do not install bronze transducers in metal hulls. This will cause electrolytic corrosion that may result in damage to the hull or transducer.

Sonar Performance: The accuracy of the sonar depth display can be affected by many factors, including the type and location of the transducer and water conditions. Ensure that the transducer is located and used correctly.

Fuel Computer: Do not rely on the fuel computer as the sole source of information regarding available fuel onboard. Fuel economy can change drastically depending on boat loading and sea conditions. Fuel Computer information should be supplemented by visual or other checks of the fuel load. This is necessary due to possible operator errors such as forgetting to reset the fuel used when filling the tank, running the engine with the Fuel Computer not switched on, or on other operator actions that may render the device inaccurate. Always carry adequate fuel onboard for the intended trip, plus a reserve to allow for unforeseen circumstances.

Failure to adhere to these warnings may lead to death, serious injury or property damage. Northstar disclaims all liability for installation or use of this product that causes or contributes to death, injury or property damage or that violates any law.

The 457/467 is set up with default units. To change the units, see section 8.6.

Contents

1 Introduction	6
1-1 Overview	6
1-2 Cleaning and maintenance	7
1-3 Removing and replacing the display unit	7
2 Basic Operation	8
2-1 Using the keys	8
2-2 Turning on and off / auto power	9
2-3 Backlight and night mode	10
2-4 Alarms	10
2-5 Simulate mode	10
2-6 The main windows	11
3 Sonar fishfinding: Introduction	16
3-1 Using the 457/467	16
3-2 Interpreting the display.....	17
3-3 Single and Dual frequency fishfinding	19
3-4 Fish detection and display.....	22
3-5 Range	23
3-6 Gain and threshold.....	24
4 Sonar fishfinding: Displays	25
4-1 Sonar history display	25
4-2 Sonar Zoom and Full Screen Zoom displays	26
4-3 Sonar Bottom display.....	27
4-4 Sonar 50/200 display	27
4-5 Sonar A-Scope display	28
5 Gauges window	29
6 Data window	29
7 Fuel functions and display	30
7-1 What the fuel computer does	30
7-2 Fuel window	30
7-3 When you add or remove fuel	31

7-4 Low fuel alarm.....	32
7-5 Boat speed sensors.....	32
7-6 Fuel consumption curves.....	34
7-7 Calibration.....	36
8 Setting up the 457/467.....	36
8-1 Setup > System.....	38
8-2 Setup > Sonar.....	39
8-3 Setup > Fuel.....	40
8-4 Setup > Logs.....	41
8-5 Setup > Alarms.....	42
8-6 Setup > Units.....	43
8-7 Setup > Comms.....	43
8-8 Setup > Calibrate.....	44
8-9 Setup > Favorites.....	45
8-10 Setup > Simulate.....	45
9 Installation.....	46
9-1 Installation: What comes with the 457/467.....	46
9-2 Installation: Options and Accessories.....	46
9-3 Installation: The display unit.....	48
9-4 Installation: Power/data cable.....	49
9-5 Installation: Sonar transducer.....	50
9-6 Installation: Northstar petrol/gasoline sensors.....	50
9-7 Installation: SmartCraft.....	51
9-8 Installation: Other NavBus instruments.....	52
9-9 Installation: Other NMEA instruments.....	52
9-10 Installation: Setup and test.....	53
Appendix A - Specifications.....	54
Appendix B - Troubleshooting.....	56
B-1 General problems.....	56
B-2 Fuel consumption problems.....	57
B-3 Sonar fishfinding problems.....	58
Appendix C - Glossary and navigation data.....	59

1 Introduction

Quick reference to the built-in and optional features:

Feature	Type	See	Requires
General	How to use the keys and displays	2	
	Troubleshooting	Appendix B	
	Simulate mode	2-5	
	Glossary of special names	Appendix C	
	Specifications	Appendix A	
Alarms	Built in alarms	2-4	
	SmartCraft engine alarms	1-1	SmartCraft
Boat data	Data at top of main windows	2-6-3	
	Dedicated data window	6	
Fuel	Fuel computer, petrol/gasoline engine	7	Fuel sensors
	Fuel computer, SmartCraft engines	7	SmartCraft
	What to do when you add or remove fuel	7-3	
Sounder	Overview of the depth sounder	3	Sounder
	Depth, bottom features, water features	3	Sounder
	Fishfinder	3	Sounder

1-1 Overview

The Northstar 457 and 467 are compact, rugged, highly integrated marine fishfinders. They are easy to use and have an easy to read color display. Complex functions can be performed with a few key presses, taking the hard work out of boating.

The available functions, displays and setup menus depend on the optional sensors and instruments that are installed:

- Fuel functions require one or more petrol/gasoline or diesel fuel sensors to be installed.
- SmartCraft engine functions require a SmartCraft system to be installed. For information on using SmartCraft, see the *SmartCraft Gateway Installation and Operation Manual*.

- The 457/467 can send data to other instruments, and receive data from other instruments.

For information on installing options, see section 9-2.

This manual describes how to install and operate the 457/467. For maximum benefit, please read this manual carefully before installing and using the unit. For more information on this instrument and other Northstar products, go to our website, www.northstarnav.com.

1-2 Cleaning and maintenance

The 457/467 screen is covered by a proprietary anti-reflection coating. To avoid damage, clean the screen only with a damp cloth and mild detergent when dirty or covered in sea salt. Avoid abrasive cleaners, petrol or other solvents.

Cover or remove a transom-mounted transducer when repainting the hull. If painting over a through hull transducer with antifouling paint, use only one coat of paint. Remove the previous coat of antifouling paint by sanding it lightly.

To optimize performance, avoid walking on or jamming cables and connectors. Keep the transducer free of weed, paint and debris. Do not use a high pressure water blast on a speed sensor paddlewheel as it may damage the bearings.

Push the dust cover over the display when the 457/467 is turned off.

1-3 Removing and replacing the display unit

If the display unit is bracket mounted then the display unit can easily be removed and replaced for security or protection.

Removing the display unit:

- 1 Turn the display unit off (see section 2-2) and put the dust cover on.
- 2 Loosen the knob on the mounting bracket and lift the unit off the bracket.
- 3 Unplug the connectors from the display unit; turning each locking collar anticlockwise until you can pull the plug out.
- 4 Push the attached dust covers over the exposed ends of the connectors.
- 5 Store the display unit in a dry clean place, such as the optional Northstar carry bag.

Replacing the display unit

- 1 Remove the dust covers from the connectors. Plug the connectors into the back of the display unit:
 - Match the connector's color to the socket color.
 - Insert each connector and turn the locking collar clockwise until it is finger tight.

Nothing will be damaged if a cable is plugged into the wrong socket by mistake.

- 2 Hold the display unit in place on the mounting bracket. Adjust the tilt of the display for best viewing, then hand tighten the knob on the mounting bracket. Remove the dust cover.



2 Basic Operation

Overview of the keys



ESC ESCAPE - Go back to an earlier menu or display.

DISP DISPLAY - Show a menu of the main displays. To go to a display, select it from the menu (see section 2-6).

▲ ▼ ◀ ▶ CURSOR KEYS - to move the cursor or the selection highlight.

MENU MENU - Show a menu of the options for the current window. Press **MENU** again to display the Setup menu (see section 8).

ENT ENTER - Start an action or accept a change.

+ - ZOOM - Zoom in or out to display different areas and detail on the chart.

AUTO AUTO - Select fishing/cruising or manual operating mode (see section 3-1).

50/200 50/200 - Changes the frequency between 50 kHz and 200kHz (see section 3-3).

⏻ POWER - Turn 457/467 on and off (see section 2-2); adjust the backlighting (see section 2-3).

2-1 Using the keys

In this manual:

Press means to push the key for less than a second.

Hold means to hold the key down.

The internal beeper beeps when a key is pressed (to disable or enable the beep, see section 8-1).

Using the menus

Operate the 457/467 by selecting items from menus. Items can be submenus, commands or data.

Selecting a submenu

A ▶ after a menu item indicates a submenu, for example System ▶. Press **▲** or **▼** to move the highlight to the submenu, then press **ENT**.

Starting a command

Press **▲** or **▼** to move the highlight to the command, for example Language, then press **ENT**.

Changing data

First press **▲** or **▼** to move the highlight to the data to change, then:

a To change a tick box

means On or Yes

means Off or No.

Press **ENT** or **▶** to change the tick box.

b To select an option

1 Press **ENT** to display the menu of options.

Palette	White
Interference filter	Black
Noise filter	Blue
Surface clutter filter	White
Pulse length	Vivid
Pulse power	8 color

2 Press **▲** or **▼** to move the highlight to the option you want, then press **ENT**.

c To change a name or number:

1 Press **ENT** to display the name or number:



2 Press **◀** or **▶** to select a letter or digit to change. Press **▲** or **▼** to change the letter or digit.

Repeat this to change other letters or numbers.

3 Press **ENT** to accept the new value. Or press **ESC** to ignore the changes.

d To change a slider value

Press **◀** to decrease the value or **▶** to increase the value.



2-2 Turning on and off / auto power

Turning on manually

If the 457/467 is not wired for auto power, press **⏻** to turn the unit on. If necessary, adjust the display to be easy to read (see section 2-3).

Note: If the 457/467 is not wired for auto power then the 457/467 does not record engine hours and might not record fuel consumption (see section 9-4).

Turning off manually

If the 457/467 is not wired for auto power or if the ignition switch is off, hold down **⏻** until the display turns off.

Auto power



If the 457/467 is wired for auto power (see section 9-4), then:

- The 457/467 automatically turns on when you turn the boat's ignition switch on.
- You can not turn the 457/467 off while the ignition switch is on.
- If Auto power off (see section 8-1) is the 457/467 automatically turns off when you turn the boat's ignition switch off.
- If Auto power off (see section 8-1) is the 457/467 stays on when you turn the boat's ignition switch off. You can now turn the 457/467 off manually.



2-3 Backlight and night mode

To go to the Backlight window, press  briefly.

Backlight

The display and keys are backlit. To change the backlight level, highlight Backlight, then press  to dim or  to brighten.



When you have finished, press .

 **Tip:** Press  twice to give the brightest screen, with maximum backlight and Night mode off.

Night mode

Night mode sets the palette for all displays.

- Normal palette, for daytime
- A palette optimised for night time.

To change mode, highlight Night mode, then press  or .

2-4 Alarms

When the 457/467 detects an alarm condition, it displays a warning message on the display, the internal beeper sounds and any external beepers or lights operate.

Press  to clear the alarm. The alarm will sound again if the alarm condition occurs again.

The 457/467 has user settable alarms (see section 8-5).

2-5 Simulate mode

In Simulate mode, the 457/467 ignores data from the sonar transducer and other transducers and sensors and the 457/467 generates this data itself. Otherwise, the 457/467 functions normally. Simulate mode allows a user to become familiar with the 457/467 off the water.

To start and stop Simulate mode, see section 8-10. In simulate mode, **Simulate** flashes at the bottom of the display.

WARNING

Never have Simulate mode on when the 457/467 is on the water.

2-6 The main windows

The display menu allows quick access to the main windows and favorites. Full-screen Sonar is at the top of the menu followed by favorites. Other windows are available from the More... sub menu.

Note:

The windows available depend on the optional sensors and instruments that are installed (see section 1-1).

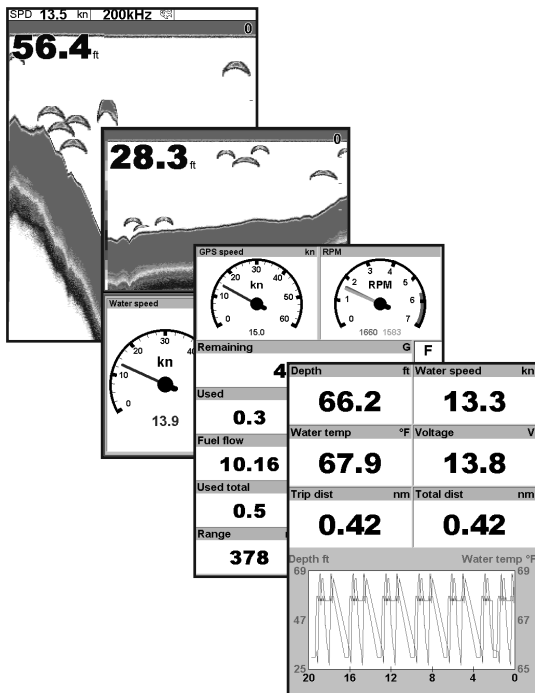
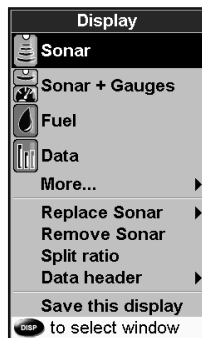

Note: The windows below the menu divider can only be shown full screen without a data header. (see section 2-6-3).

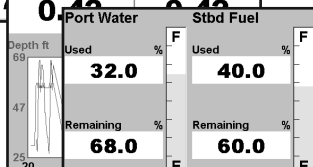
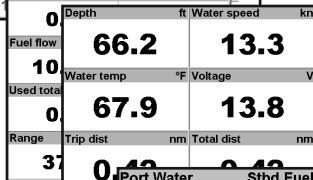
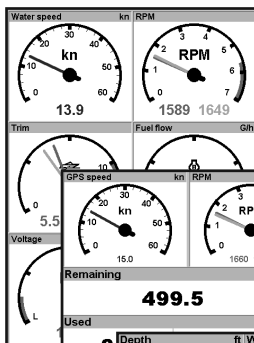

Engine faults	Engine fault history
Fault details	Level
1) Guardian engine power limited Starboard Engine limited to 0%	⚠
2) Reserve oil level low Starboard Engine 0% Remaining	⚠
3) Reserve oil level low Port Engine 0% Remaining	⚠
4) Remote oil level low Port Engine	⚠
5) RPM over speed Port Engine	⚠
6) Engine voltage high Starboard Engine	⚠
7) Engine voltage low Port Engine	⚠
8) Oil pressure low Starboard Engine	⚠
9) Water pressure low Starboard Engine	⚠
10) Engine overheating Starboard Engine	⚠
11) Drive lube low Port Engine	⚠

Used: 28

Remaining: 72

⏪ to page up/down ⏩ for details

2-6-1 Multi window displays

The 457/467 can show two windows at once.

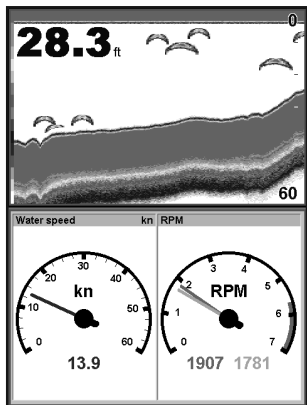

Adding a window to the display

Press **DISP**, select Add window and select a window to add. The 457/467 automatically rearranges the display to show the new window.

Changing window size

- 1 Press **DISP** and select Split ratio.
- 2 Press **▲** or **▼** to change the height of the windows.
Note: Some windows are fixed in size.
- 3 Press **ENT**.

Exchanging two windows on the display

- 1 Press **DISP** twice to change the active window.
- 2 Press **DISP**, select Replace and select the second window.

The 457/467 exchanges the two windows.

Replacing a window on the display

- 1 Press **DISP** twice to change the active window.
- 2 Press **DISP**, select Replace and select a new window that is not currently visible.

Note:

When some windows are small then not all the data is shown.

The active window

If there is more than one window displayed, the active window is indicated by a red border. Press **DISP** twice to change the active window.

Pressing **MENU** will display the options menu for the active window.

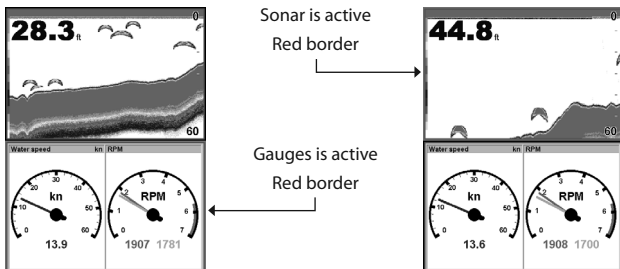

2-6-2 Favorite displays

The 457/467 has a list of commonly used displays, called favorite displays. There can be up to six favorite displays.

Sonar, Gauges, Fuel, Data, and Tanks windows can be combined in a display. Each of these displays can have a data header (see section 2-6-3).

Selecting a favorite display

Press **DISP** and select a favorite from the menu.

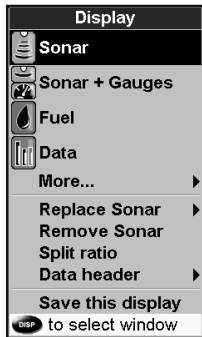

Adding a favorite display to the list

- 1 Set up the display with the window or windows you want in the new favorite (see section 2-6).
- 2 Press **DISP** and select Save this display. The 457/467 displays the favorites list.
- 3 Select where in the list to add the new favorite. If you select an existing favorite display then the new favorite will replace the existing favorite in the list.

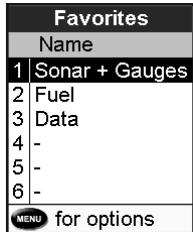

Deleting a favorite display from the list

- 1 Press **MENU** twice then select Favorites.
- 2 Highlight the display to delete, press **MENU** and select Delete.

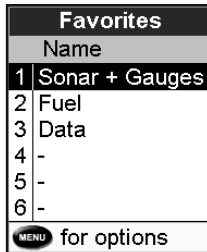

Changing the order of the favorites list

- 1 Press **MENU** twice then select Favorites.
- 2 Highlight the display to move, press **MENU** and select Move up or Move down.

2-6-3 Data header

The displays can show data at the top, called the data header.

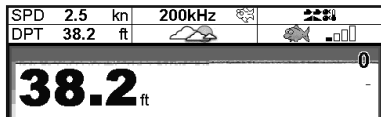

When you select a window from the display menu (see section 2-6) the 457/467 displays an appropriate data header for the window.

Each favorite display (see section 2-6-2) has its own data header. When you select a favorite display, the 457/467 recalls the data header for this favorite.

Setting the data header for a display

- 1 Press **DISP** and select Data header.
- 2 To turn the data header on or off:
 - i Select Data.
 - ii Select or
- 3 To select the size of the data:
 - i Select Size.
 - ii Select the size to display.
- 4 To change the data displayed:
 - i Select Data setup.
 - ii Change a data field:
 - a Press the cursor keys to highlight the field.
 - b Press **ENT** to display a menu of data items.
 - c Select a data item that is available on your system or select None to leave the field empty.
 - iii Repeat the above step to set the other data fields.

Tip: If all fields in a line are None then the line will not be displayed and the data header will take less space on the display.

5 Press **ESC**.

Tip: The data header will change when you select another display. To set a data header that you can recall later, set the header as part of a favorites display (see below).

Favorites displays and data headers

To set a data header for a favorites display, follow the steps to add a favorite (see section 2-6-2 - Adding a favorite display to the list). In step 1, set the data header for the favorite as described above.

Note: Only the Sonar, Gauges, Fuel, Data, and Tanks windows can have a data header.

3 Sonar fishfinding: Introduction

Sonar functions require the optional sonar transducer to be installed and set up.

This section explains how to interpret the sonar displays, when and why to use the different frequencies and how fish are detected and displayed.

3-1 Using the 457/467

The 457/467 uses a sonar transducer attached to the hull. The transducer generates an ultrasonic pulse (sound that is above the hearing range of the human ear), which travels down towards the bottom at a speed of about 4800 ft/sec (1463 m/sec), spreading out into a cone shape.

When the pulse meets an object, such as a fish or the bottom, it is partly reflected back up towards the boat as an echo. The depth of the object or bottom is calculated by the 457/467 by measuring the time taken between sending a pulse and receiving the echo. When an echo has been returned, the next pulse is sent.

The 457/467 converts each echo into an electronic signal, displayed as a vertical line of pixels. The most recent echo appears on the extreme right of the display, with the older echoes being scrolled towards the left, eventually disappearing off the display.

The scroll speed depends upon the water depth and scroll speed setting. See sections 8-2 and section 3-2, for more information.

The appearance of echoes displayed are affected by:

- the 457/467 settings (see sections 8-2, 3-5 and 3-6)
- echoes (different fish types, different bottom types, wrecks and seaweed; see section 3-2)
- noise (water clarity and bubbles; see section 3-2).

It also describes Gain and Range and shows examples of some of the different sonar displays.

Cruising, Fishing and Manual Modes

The 457/467 has three sonar operating modes:

- **Cruising mode:** Use this when on the move. The 457/467 automatically adjusts its settings to compensate for water clarity and to display the bottom.
- **Fishing mode:** Use this when fishing. The 457/467 automatically adjusts its settings to compensate for water clarity and to best display fish, the bottom and other details.
- **Manual mode:** Use this to fine-tune the 457/467 settings by hand. Best results are often achieved in manual mode, but practice and experience are required to obtain the optimum settings for different conditions.

For more information about modes, see sections 3-5 and 3-6.

WARNING

Use the automatic Cruising or Fishing modes when learning to use the 457/467 or when travelling at speed.

3-2 Interpreting the display

The sonar displays do not show a fixed distance travelled by the boat; rather, they display a history, showing what has passed below the boat during a certain period of time.

The history of the sonar signal displayed depends the depth of the water and the scroll speed setting.

In shallow water, the echoes have a short distance to travel between the bottom and the boat. In deep water, the history moves across the display more slowly because the echoes take longer to travel between the bottom and the boat. For example, when the scroll speed is set to **Fast**, at depths over 1000 ft (300 m) it takes about 6 minutes for the data to move across the display, whereas at 20 ft (6 m) it takes only about 10 seconds.

The scroll speed can be set by the user to display either a longer history with less fish information or a shorter history with more fish details (see section 8-2).

If the boat is anchored, the echoes all come from the same area of bottom. This produces a flat bottom trace on the display.

The screen shot shows a typical sonar display with the Fish symbols turned **Off**.

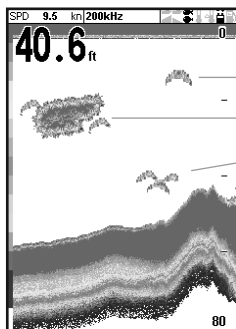

- A Single fish
- B Large school of fish
- C Small school of fish
- D Bottom

Strength of echoes

The colors indicate differences in the strength of the echo. The strength varies with several factors, such as the:

- Size of the fish, school of fish or other object.
- Depth of the fish or object.
- Location of the fish or object. (The area covered by the ultrasonic pulse is a rough cone shape and the echoes are strongest in the middle.)
- Clarity of water. Particles or air in the water reduce the strength of the echo.
- Composition or density of the object or bottom.

CAUTION

Note: Planing hulls at speed produce air bubbles and turbulent water that bombard the transducer. The resulting ultrasonic noise may be picked up by the transducer and obscure the real echoes.

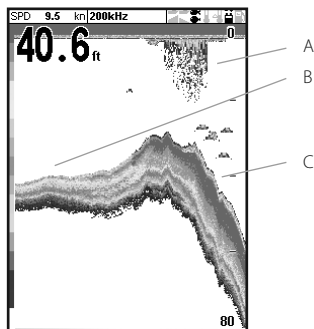

- A Kelp / Weed
- B Soft bottoms such as mud, weed and sand show as narrow bands
- C Hard bottoms such as rock or coral show as wide bands

Bottom types

Mud, weed and sandy bottoms tend to weaken and scatter the sonar pulse, resulting in a weak echo. Hard, rocky or coral bottoms reflect the pulse, resulting in a strong echo.

Frequency and cone width

The sonar pulse generated by the 457/467 transducer travels down through the water, spreading outwards in a cone shape. The cone width is dependent upon the frequency of the pulse; at 50 kHz it is approximately 45°, and at 200 kHz it is approximately 11°.

The differences in the cone width affect what is displayed. See section 3-3.

Water Depth	Cone width at 50 kHz	Cone width at 200 kHz
25	20	5
50	40	10
100	80	20
150	130	30
200	170	40
300	250	60
400	330	80
600	500	120
800	660	150
1000	830	190

45° cone

11° cone

Shadows

Shadows are created around areas where the ultrasonic beam cannot 'see'. These areas include hollows on the bottom or beside rocks and ledges, where the strong echoes returned off the rocks obscure the weak echoes of the fish and may also create a double bottom trace. See following for an example of the sonar display in such an environment. A double bottom trace is shown on the display.

When looking for fish with the wide angled 50 kHz frequency, be aware of increased shadows. Use the high frequency 200 kHz in areas that have rocks and ledges because this frequency reduces the shadow effect considerably.

Example of shadows

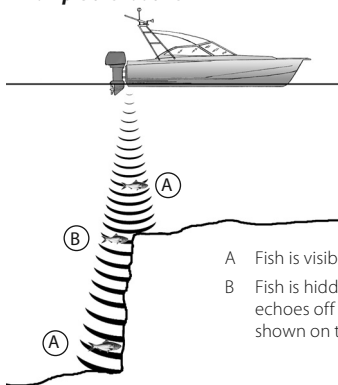

Sonar display of same area

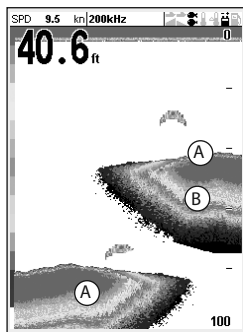

3-3 Single and Dual frequency fishfinding

Sonar frequencies

The 457/467 has two sonar frequencies, 200 kHz and 50 kHz. To select the sonar frequency to use:

- 1 Go to a sonar display (see section 4).
- 2 Press **MENU**, select **Frequency** and select **200 kHz**, **50 kHz**, or **Mixed**. Or, press **50/200** to quickly switch between **200 kHz** and **50 kHz** frequencies.

When to use 200 kHz

The 200 kHz frequency is especially suitable for use in shallow and medium depth water, typically less than 500 ft (150 m) and while running at speed.

At 200 kHz, the narrow cone reduces any noise caused by air bubbles.

The 200 kHz frequency generates a higher definition pulse which produces little shadow and returns excellent detail over a small area

of bottom. Therefore, it gives excellent bottom discrimination capability and is particularly good at showing individual fish, including bottom dwellers.

When to use 50 kHz

The 50 kHz frequency is particularly suitable for use in deep water, typically greater than 500 ft (150 m).

At 50 kHz, the cone covers an area of water about four times wider than the 200 kHz cone and penetrates to a greater depth with minimal loss of the return signal.

However, it produces a lower definition display with more shadow compared to the 200 kHz frequency. This means that a group of small fish, for example, could be displayed as a single item, while any fish very close to the bottom may not be found at all.

This frequency is useful for getting a deep, wide overview of the area so that any areas of interest can be identified and then examined in detail with the 200 kHz frequency.

When to use Mixed

The Mixed frequency combines the 200 kHz and the 50 kHz echoes on one sonar display, filling in detailed echoes in the center of the sonar cone.

When to use 50/200 kHz

Operating the 457/467 at both 50 kHz and 200 kHz simultaneously on a split display can be very useful when operating in shallow to medium water, typically less than 500 ft (150 m), because the 50 kHz section of the display shows the general area, while the 200 kHz section can be viewed simultaneously for a more detailed look at any interesting feature.

To use 50/200 kHz, select the Split 50/200 display (see section 4-4).

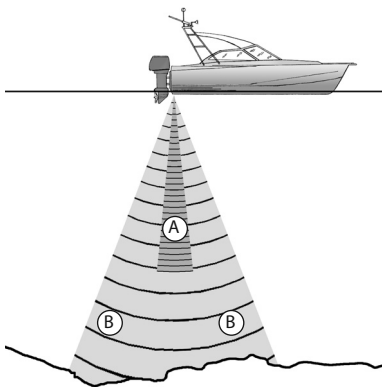

A Narrow angle, more detailed 200 kHz cone

B Wide angle, less detailed 50 kHz cone

Comparison of the same fish scenario displayed at different frequencies:

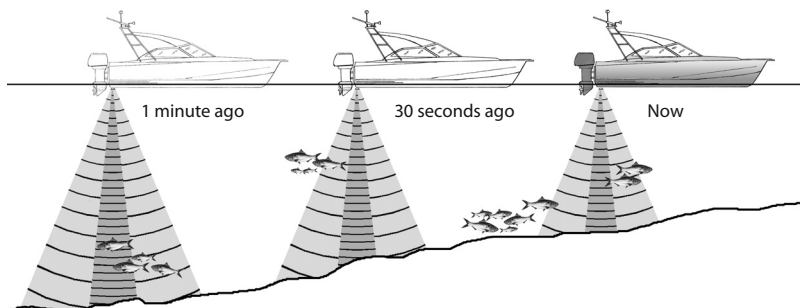

50 kHz display

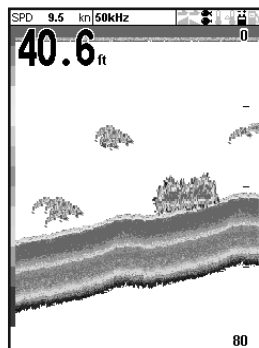

200 kHz display

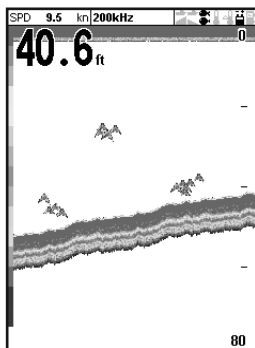

200/50 KHz display

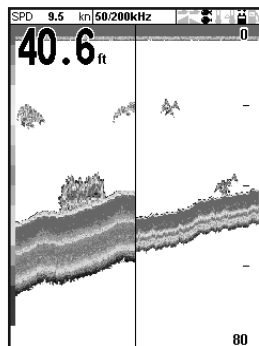

Mixed display

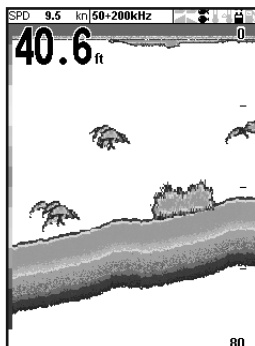

3-4 Fish detection and display

Where to find fish

Underwater features like reefs, wrecks and rocky outcrops attract fish. Use the 50 kHz or 50/200 kHz frequency display to find these features, then look for fish by passing over the feature slowly several times using the Zoom display (see section 4-2). If there is a current, the fish will often be found downstream of the feature.

When fishing with the 457/467 with the Fish symbols **OFF**, a weak fuzzy band may appear between the bottom trace and surface. This might indicate a thermocline - a rapid change in water temperature, such as the edge of a warm or cold current. The temperature difference can form a barrier which the fish may not swim through. In fresh water, fish often collect around a thermocline.

Fish symbols

The 457/467 uses Northstar's SBN *II* technology to analyse sonar echoes and identify which are likely to be fish. The 457/467 can be set up to display a fish symbol and the depth over these echoes (see section 8-2, Fish symbols). While SBN *II* is very sophisticated it is not foolproof - there will be times when the 457/467 will not be able to differentiate between fish and large air bubbles or rubbish.

Depending on the strength of a fish signal, the 457/467 can display a small, medium or large symbol (see section 8-2, Fish filter). The color of the fish symbol depends on the frequency being used. If the 50 kHz frequency is selected, the fish symbols will be grey. If the 200 kHz frequency is selected, the fish symbols will be orange. If the mixed frequency is selected, fish within the 50 kHz beam will be grey, fish within the 200 kHz beam will be orange, and fish within both beams will be displayed in red.

To see the maximum amount of information from the echoes, turn Fish symbols off. Fish appear as arches on the display.

Fish arches

In good conditions, a fish passing through the cone-shaped ultrasonic pulse is displayed as a fish arch. The 50 kHz frequency uses a wider cone than the 200 kHz frequency. This makes the fish arches easier to see.

A fish arch starts when a fish enters the weak edge of the sonar cone, generating a weak echo that is displayed as the start of the fish arch. As the fish moves closer to the middle of the cone, the distance between the transducer and the fish reduces and the echo is displayed at progressively shallower depths, producing a rising shape. When the fish passes directly beneath the middle of the cone, the echo becomes strongest and thickest. As the fish passes out of the middle of the cone the reverse happens with a progressively weaker and deeper echo.

There are many reasons why fish arches may not be seen. For example:

- Poor transducer installation (see *Transom Transducers Installation Guide*).
- If the boat is anchored then fish will tend to show on the display as horizontal lines as they swim into and out of the transducer sonar beam. Slow speeds in deeper water give the best fish arch returns.
- Range is important. It will be much easier to see fish arches when using zoom mode to concentrate on a particular section of water, rather than just displaying everything from the surface to the bottom. Zooming increases screen resolution and is necessary for good fish arches.



Fun fish symbol



Normal fish symbol



Fun symbol + depth



Fish arch + depth

- It is difficult to get fish arches in shallow water as the transducer sonar beam is very narrow near the surface and fish do not stay within the beam long enough to display an arch. Several fish in shallow water tend to display as randomly stacked areas of color.
- Wave motion may result in distorted fish arches.

3-5 Range

Range is the vertical depth displayed on the 457/467 sonar display. For example, if the range is 100 ft, then the sonar display shows depths between 0 and 100 ft. The range is displayed at the bottom, right corner of a sonar display.

The 457/467 has two range modes:

Auto: The 457/467 adjusts the range automatically so that the bottom of the water is always shown at the bottom of the display. Auto range is recommended for normal operation.

To set Auto mode:

- 1 Go to a sonar display (see section 4).
- 2 Press **MENU**, select **Range** and select **Auto**.

 **Tip:** To quickly enlarge from manual to autorange hold down the + or - key for 1.5 seconds

Manual: The 457/467 does not adjust the range automatically. If the bottom depth is below the range, the bottom will not appear on the display. Manual range is useful if the bottom depth changes rapidly, because Auto range will cause the display to change range frequently.

To set Manual range or to change the range:

- 1 Go to a sonar display (see section 4).
- 2 Either press **+** to increase range or press **-** to decrease range

WARNING

Use the Auto range when learning to use the 457/467 or when travelling at speed.

Zoom range and offset

The sonar Zoom and Bottom displays can show a magnified part of the range (see sections 4-2 and 4-3).

3-6 Gain and threshold

Gain and threshold settings control the amount of detail displayed on a sonar display:

Gain: The gain of the sonar receiver. The gain should be high to display good detail, but if the gain is too high then information from the strong bottom signal is lost and false echoes might be displayed.

Threshold: Return echoes less than the threshold are ignored. The threshold should be as low as possible, but if the threshold is too low, unwanted noise will be displayed. Threshold is set as a percentage of gain. For example, if the threshold is 50%, then return echoes less than 50% of the maximum signal are ignored.

The gain window

To display or change the current settings for gain, select a sonar display and press **ENT**. Select **Threshold** to display the thresholds. There are separate gain and threshold settings for each sonar frequency, 50 kHz and 200 kHz.

Gain	
Mode	Manual
200kHz	13
50kHz	13
Threshold	<input checked="" type="checkbox"/>
200kHz	15%
50kHz	15%





This display is called the gain window.

Changing mode

The 457/467 has three operating modes. In Cruising and Fishing modes, the 457/467 automatically adjusts gain and threshold for good performance. In manual mode, you can hand adjust the settings.

To change the mode from the Gain window, Select **Mode** and then select **Fishing**, **Cruising** or **Manual**. When you select **Manual**, the 457/467 reverts to your last manual settings.

Changing gain and threshold

- 1 In the Gain window, press  or  to select the setting to adjust.
- 2 Press  or  adjust the setting. The 457/467 changes to Manual mode.

 **Tip:** Use the A-scope display to help set gain or threshold manually (see section 4-5).

4 Sonar fishfinding: Displays

To show the Sonar window, press **DISP**, then select Sonar.

There are six kinds of sonar window. To use a window, press **MENU**, select Sonar splits, then select the type of window to use:

No split: Sonar history window at a single or mixed frequency (see section 4-1).

Split zoom: Sonar history plus a zoomed section (see section 4-2).

Full screen zoom:

See section 4-2.

Split bottom: Sonar history plus a bottom trace in a zoomed section (see section 4-3).

Split 50/200: Sonar histories at 50 and 200 kHz (see section 4-4).

Split A-Scope: Sonar history plus echo strength (see section 4-5).

If the window is split, adjust the split ratio if required:

- 1 Press **MENU** and select Sonar window split.
- 2 Press **←** or **→** to adjust the ratio.
- 3 Press **ENT**.

Options	
Sonar splits	No Split
Frequency	No Split
Gain	Split Zoom
Range	Full screen zoom
A-Scope	Split Bottom
MENU for setup	Split 50 / 200
	Split A-Scope

4-1 Sonar history display

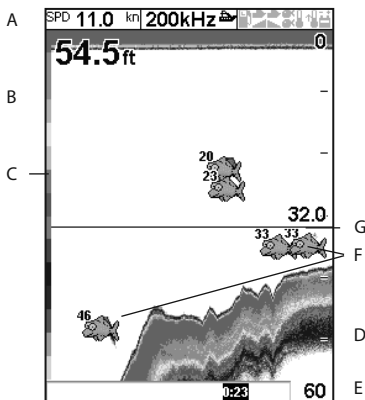

A Optional data header (see section 2-6-3)

B Depth

C Color bar

D Bottom

E Range

F Fish symbols with depth

G Depth line

The window scrolls from right (most recent echoes) to left (oldest echoes).

4-1-1 Extended history mode

To review an old sonar echo, use ◀ or ▶ to move back and forward through the sonar history. The time since the echoes shown on the screen were recorded is displayed at the bottom of the screen. Press **ESC** to return to the most recent echo.

The digital depth shown is always the current depth, even in extended history mode.

The History Position Bar indicates the age of the most recent echo on the screen, and the position of the current screen in the recorded history.

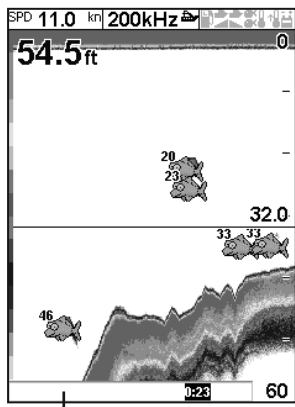

History position bar

4-2 Sonar Zoom and Full Screen Zoom displays

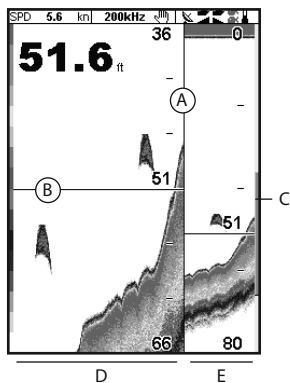

- A Divider line
- B Depth line marks the center of the zoomed area
- C Zoom bar
- D Zoom section
- E Sonar history

These windows show a zoomed section of the sonar history. The Sonar Zoom display shows the sonar history on the right and the zoomed section on the left. The Full Screen Zoom display shows the zoomed section only.

The zoom bar on the far right shows the area of the history that is magnified in the zoom section:

- Press ◀ or ▶ to adjust the zoom range (the range of depths included in the zoom section).
- If **Bottom lock** is on, the zoom depth (the depth of the zoom section) is adjusted automatically so that the bottom is always displayed in the zoom section.

If **Bottom lock** is off, press ▲ or ▼ to manually adjust the zoom depth.

Bottom lock

To turn **Bottom lock** on or off:

- 1 Press **MENU** and select **Bottom lock**.
- 2 Select **On** or **Off**.

or If **Bottom lock** is on, pressing ▲ or ▼ will turn it off.

4-3 Sonar Bottom display

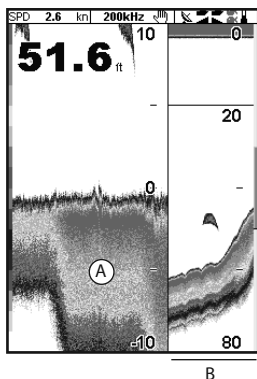

- A Zoomed bottom signal
B Sonar history

The window shows the sonar history on the right and the bottom signal as a flat trace in the center of the zoom section on the left. The flat trace makes it easy to compare the echo strengths shown in the bottom signals. This can help to identify the type of bottom and objects close to the bottom.

The zoom bar on the far right shows the area of the history that is magnified in the zoom section:

- Use the ◀ or ▶ keys to adjust the zoom range.
- The 457/467 calculates the zoom depth automatically.

It is not necessary to turn Bottom lock on for this display.

4-4 Sonar 50/200 display

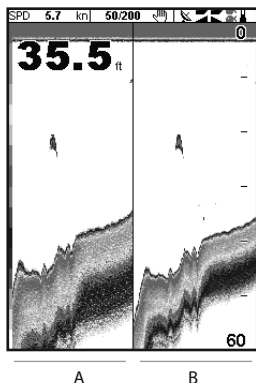

The window shows:

- A the 50 kHz sonar history on the left
B the 200 kHz sonar history on the right.

Gain can be set independently for each frequency (see section 3-6). Range applies to both frequencies (see section 3-5).

4-5 Sonar A-Scope display

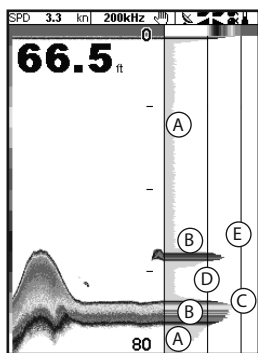

The window shows the sonar history on the left and the A-Scope display on the right. The A-Scope shows:

- A, B, C The strengths of echoes being received now from different depths - the longer the horizontal line the stronger the signal:
 - A Unwanted noise echoes.
 - B Echoes from fish and the bottom
 - C The strongest echo, usually from the bottom
 - D A vertical line showing the threshold, the weakest echo to display on the sonar history
 - E A vertical line showing the gain setting; echoes above this strength will display as the maximum signal strength
- Use the A-Scope while adjusting the gain and threshold settings manually.

Fish recognition

The echo strengths shown on the A-scope can be useful in recognising the type of fish. Different species of fish have different sizes and shapes of swim bladders. The air in the swim bladder reflects the ultrasonic pulse, so the strength of the echo varies between fish species according to the size and shape of the swim bladder.

When catching fish from a school, note the species and the strength of the echo that it returns on the A-scope. Then, when that particular echo is seen again, it is likely to be the same fish species.

Bottom type

The shape of the echo strengths in the A-Scope can help you to recognise the type of bottom.

Using the A-Scope to set gain and threshold manually

It is convenient to use the A-scope display when adjusting gain and threshold manually. Follow this procedure to adjust gain and threshold for normal circumstances:

- 1 Switch to the Sonar A-Scope display. If necessary, press **+** or **-** to adjust range so that the bottom is displayed.
- 2 If necessary, press **50/200** to select the sonar frequency to adjust the settings for.
- 3 Press **ENT** to display the Gain window. To adjust gain or threshold for a frequency, press **▲** or **▼** to select the setting to adjust, then press **←** or **→** to change the setting.
- 4 Set threshold to zero.
- 5 Adjust Gain so the peak of the strong signal from the bottom just touches the gain line.
- 6 Adjust threshold so that it is just to the right of the noise.
- 7 Press **ESC** to close the gain window.
- 8 If required, repeat these steps to adjust gain and threshold for the other frequency.

Note: Setting the gain higher will display more detail from weak echoes, like fish, but will lose detail from the strong echo from the bottom.

5 Gauges window

The Gauges window shows boat data, such as water speed, as analog gauges. To select the Gauges window, press **DISP**, select More, then select Gauges. Before using the Gauges window, set Speed range, Max RPM and Max fuel flow (see section 8-3).

Selecting a Gauges layout

To select a layout from the Gauges window, press **MENU**, select Layout, then select a layout from the list.

Changing a gauge layout

You can change the data displayed on each gauge in a layout.

- 1 Select the layout to change (see above).
- 2 Press **MENU** and select Gauge setup.
- 3 Highlight the gauge to change. Press **ENT** and select the data to display in the gauge.
- 4 Repeat the above step to change other gauges.
- 5 Press **ESC**.

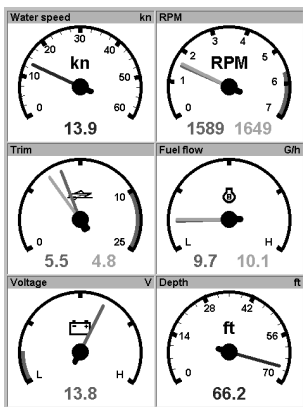

6 Data window

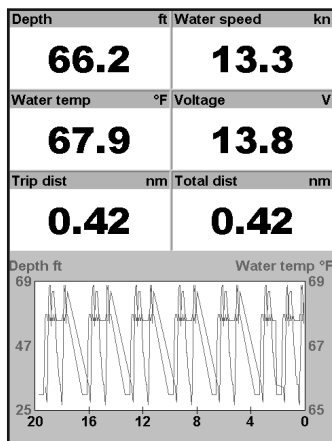

The data window has large numeric data fields and a graph of depth and water temperature if available. To go to the data window, press **DISP**, select **Other**, then select **Data**.

To select what data is displayed:

- 1 Press **MENU** and select **Data setup**.
- 2 Change a data field:
 - i Press the cursor keys to highlight the field.
 - ii Press **ENT** to display a menu of data items.
 - iii Select a data item that is available on your system or select **None** to leave the field empty.
- 3 Repeat the above step to set the other data fields.
- 4 Press **ESC**.

The time base of the graph can be changed by pressing **MENU**, selecting **Time Base**, pressing **ENT**, and selecting the required time base from the list.

7 Fuel functions and display

The Fuel functions require optional petrol/gasoline, diesel or SmartCraft fuel sensors to be installed and set up.

7-1 What the fuel computer does

Each engine has a flow sensor installed to measure the engine's fuel flow.

The 457/467 uses these flows, together with boat speed and engine RPM if available to estimate the fuel remaining in the tank(s), fuel used, range and fuel economy. This data is displayed on the fuel window (see section 7-2).

You can:

- display the fuel used during a trip (see section 7-2)
- set low fuel alarms (see section 7-4)
- make fuel consumption curves - graphs of fuel consumption and boat speed as a function of engine RPM - to monitor and optimise boat performance. (see section 7-6)

7-2 Fuel window

To go to the Fuel window, press **DISP**, select **More**, then select **Fuel**.

The display differs according to the number of engines and tanks. If engine RPM is available and if you have made and selected a Fuel Consumption Curve (see section 7-6), press **▶** to switch between a Summary or a Fuel curve display.

The Fuel window shows

Speed

To select a boat speed sensor, see section 7-5-1.

RPM (if available)

If engine RPM is not available, the display shows depth.

Remaining

The fuel remaining in the tank(s) is shown as a vertical gauge on the right of the display. The height of the yellow bar(s) show how much fuel remains in the tank(s). If you have set a low fuel alarm (see section 7-4), a red bar shows the level at which the alarm will trigger. If there are two tanks, the left bar shows the port tank, the right bar shows the starboard tank.

WARNING

To ensure the fuel data is accurate:

- When you add or remove fuel from a tank, tell the 457/467 (see section 7-3)
- If the boat has petrol/gasoline sensors, calibrate them during installation or if the fuel readings seem inaccurate (see section 7-7)
- Choose an appropriate type of boat speed sensor to calculate economy, range and the fuel consumption curve (see section 7-5)
- If the boat uses a paddlewheel sensor to measure speed, calibrate it during installation or if the speed readings seem inaccurate.

Used

The fuel used during a trip. On a multi-engine boat, the data for the port engine is on the left of the display.

When you want to start measuring how much fuel is used, go to the Fuel window and:

- In a single engine boat, press **MENU** and select **Clear used**.
- In a multi-engine boat, the fuel used by each engine and the total fuel used are shown. Press **MENU**, select **Clear used** and select:
 - **Port** or **Starboard** to clear the fuel used by one engine
 - **Both** to clear the total fuel used.

Fuel flow

The fuel flow for the engine(s). On a multi engine boat, the data for the port engine is on the left of the display. Use the flows to check the load of each engine.

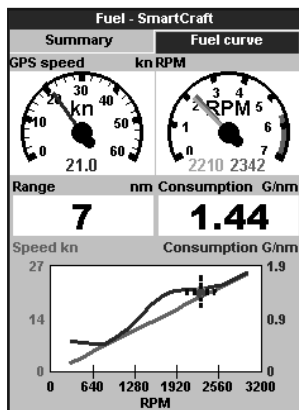
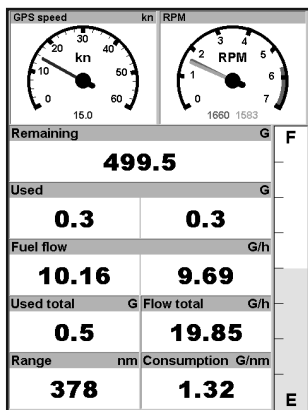

Range

The estimated boat range at the current fuel flow. The value can depend on the type of speed sensor (see section 7-5).

Economy

The distance travelled per unit of fuel used. The value can depend on the type of speed sensor (see section 7-5). The larger the value, the better the fuel economy. Adjust the throttle and trim to achieve the best economy.

Fuel consumption curve

A graph of fuel consumption and boat speed as a function of engine RPM. Use the curve to monitor and optimise boat performance (see section 7-6).

7-3 When you add or remove fuel

When you add or remove fuel, you must tell the 457/467, otherwise the fuel data will be meaningless.

A When you completely fill a tank

Go to the fuel window and press **MENU**.

Then:

- On a single-tank boat, select **Fill tank**.
- On a multi-tank boat, select **Fill tank**, then select the tank you have filled.

Note: Underfloor fuel tanks are often difficult to refill to the same level twice, due to air pockets.

With underfloor fuel tanks:

- Trim the boat to the same angle in the water each time you follow procedure A.
- Mostly use procedure B below when adding fuel, but completely fill the tank and follow procedure A about every tenth time you add fuel.

B When you partially fill a tank

- 1 Add fuel to a tank and write down how much fuel you add.
- 2 From the Fuel window, press **MENU** and select **Add fuel**.
- 3 On a multi-tank boat, select the tank that you have added fuel to.
- 4 Change the number to the amount of fuel that you added.

Note: If you follow procedure B every time you add fuel, then a small error will accumulate, because it is hard to measure exactly how much fuel you add. To avoid this, completely fill the tank and follow procedure A about every tenth time you add fuel.

C When you remove fuel

1. Before removing fuel, go to the Fuel window, press **MENU** and select **Set remaining**.
2. On a multi-tank boat, select the tank that you are removing fuel from.
3. Write down the value of Remaining for the tank; this is the amount of fuel originally in the tank.
4. Remove fuel from the tank and write down how much fuel you remove.

5. Subtract the amount of fuel you removed from the amount of fuel originally in the tank to calculate the amount of fuel now in the tank.
6. Change the number on the Set Remaining menu to the amount of fuel that you calculated was now in the tank.
7. Press **ENT**.

Note: You can also use this procedure when you add fuel to a tank. In this case, add the fuel you have added to the amount of fuel originally in the tank to calculate the amount of fuel now in the tank.

7-4 Low fuel alarm

To set a low fuel alarm for a tank:

1. Press **MENU** twice, select **Fuel** then select **Setup tanks**.
2. On a multi-tank boat, select the tank to set the alarm for.
3. Select **Tank alarm** and enter a fuel level to trigger the low fuel alarm.

When a low fuel alarm is set, the alarm's fuel level is shown on the fuel window tank levels as a red bar. The alarm can also be set using the Alarms setup menu (see section 8-5)

7-5 Boat speed sensors

7-5-1 Selecting a boat speed sensor

The fuel calculations can use boat speeds from the paddlewheel sensor, or from a GPS or pitot sensor if these optional sensors are installed:

- Paddlewheel and pitot sensors measure the speed through the water; GPS speed is speed over ground; these sensors can give different values for Range, Economy and the fuel consumption curves (see section 7-5-2).
- A pitot sensor is more accurate than a paddlewheel sensor at high speeds but is not accurate at low speeds. A paddlewheel sensor is more accurate than a pitot sensor at low speeds.

To select an optional speed sensor

1. Press **MENU** twice, select **Fuel** and select **Speed source**.
2. To use a paddlewheel or pitot sensor, select **Water speed**, otherwise select **Ground speed** to use GPS speed.
3. If you selected Water speed and you have both a paddlewheel sensor and a pitot sensor:
 - i. Press **ESC**, select **Smartcraft** and select **Speed type**
 - ii. Select **Paddlewheel** or **Pitot**.

 **Tip:** You can select a different speed sensor during a trip.

7-5-2 Water speed and ground speed

A paddlewheel sensor and a pitot sensor measure water speed, the boat speed through the water. A GPS measures ground speed, the boat speed over the bottom of the water. If there is a current, then these speeds will be different, and the log, trip log, economy and range will be different, as shown below.

Water speed is better for measuring the boat's potential performance, Ground speed is better for going to a destination because it takes currents into account. To select a speed sensor, see section 7-5-1.

When the current is from ahead, ground speed is less than water speed

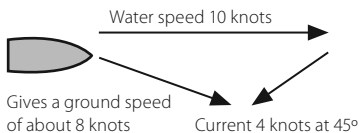
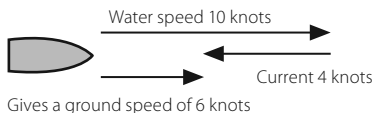

For this example:

If the boat travels for one hour, uses 3 gallons of fuel per hour and has 50 gallons of fuel left:

	Speed	Log	Economy	Range
Using water speed:	10 knots	10 nm	3.3 nm / gal	165 nm
Using ground speed:	6 knots	6 nm	2.0 nm / gal	100 nm

When the current is from behind, ground speed is more than water speed

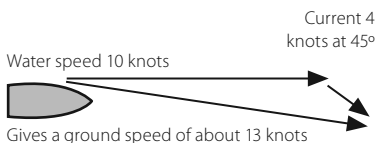
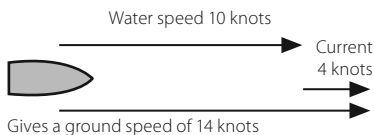

For this example:

If the boat travels for one hour, uses 3 gallons of fuel and has 50 gallons of fuel left:

	Speed	Log	Economy	Range
Using water speed:	10 knots	10 nm	3.3 nm / gal	165 nm
Using ground speed:	14 knots	14 nm	4.7 nm / gal	235 nm

7-6 Fuel consumption curves

A fuel consumption curve shows fuel consumption (fuel used per unit of distance travelled) and boat speed as a function of engine RPM. Fuel consumption curves require engine RPM, which requires SmartCraft or diesel sensors to be installed. Fuel consumption curves are powerful tools for assessing boat performance in different conditions and for helping you to run at the most economical speed for the conditions.

7-6-1 Making a fuel consumption curve

To make a fuel consumption curve you will need to run the boat in a straight line for about 15 minutes using the engine's full RPM range. For your first curve, choose a calm day with light wind and little current; have a typical load and a freshly cleaned hull. Later, you can make fuel consumption curves for different boat, weather or sea conditions. Compare these with your first curve to see how your boat's performance changes with conditions.

Making a curve

- 1 Start running the boat in a straight line.
- 2 Choose a speed source for the curve (see section 7-5-1). Normally choose Water speed to measure the boat's potential performance.
- 3 Press **MENU** twice, then select **Fuel**.
- 4 Select **Fuel consumption curve**, then select **New**.
- 5 Enter the comfortable maximum RPM you know you can achieve for the engine rather than the maker's value.

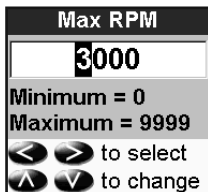

- 6 The 457/467 then asks you to set the minimum RPM. Set the throttle to idle; on a multi engine boat set all engines to about the same idle RPM.
Now, do not change the engine speed. Wait for about 60 seconds for the boat to stabilise, then press **ENT**. Wait while the fuel computer records the data.

- 7 The 457/467 then asks you to set the throttle to achieve a target RPM. On a multi engine boat set all engines to about the target RPM. When the engine RPMs are correct, the Target RPM box will turn green.
Now, do not change the engine speed. Wait for about 60 seconds for the boat to stabilise, ensuring the Target RPM box stays green. Then press **ENT**. Wait while the fuel computer records the data.

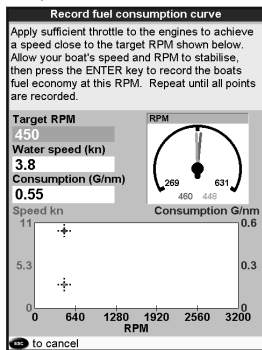

- 8 The 457/467 repeats the above step to record data up to the maximum RPM. Then the 457/467 asks if you want to save the curve. Select Yes. The fuel computer asks for a name for the curve. Change the default name if required. Then press **ENT**. The 457/467 stores the new curve.

Note To interrupt making the curve at any time, press **ESC**.

7-6-2 Managing fuel consumption curves

Renaming a curve

- 1 Press **MENU** twice, then select **Fuel**.
- 2 Select **Fuel consumption curve**. Select **Name** and select the name of the curve to rename.
- 3 Select **Rename** and press **ENT**. Change the name.

7-6-3 Using fuel consumption curves

Deleting a curve

- 1 Press **MENU** twice, then select **Fuel**.
- 2 Select **Fuel consumption curve**. Select **Name** and select the name of the curve to delete.
- 3 Select **Delete**.

Selecting a curve

- 1 You must make a fuel consumption curve before you can use it (see section 6-6-1).
- 2 On the Fuel window, press **MENU**, select Fuel consumption curve and select the name of the curve to use.
- 3 On the fuel window, press **▶** if necessary to select Fuel curve and display the fuel consumption curve.

Note

- a On a multi engine boat, keep the RPM of all engines similar while using a curve.
- b The shape of the curve depends on the type of speed sensor you selected when making the curve (see section 7-5).

Using a curve

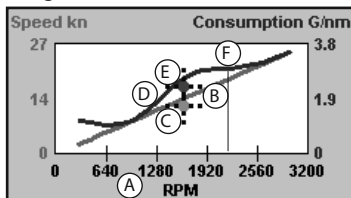

Compare your boat's performance now, at the current RPMs, with the boat's performance when you made the curve. You can compare your boat's performance now with a curve made under ideal conditions or with a curve made under similar conditions.

Information in a curve

- A RPM of the boat now. For a twin engine boat, the RPM is the average of the two RPMs.
- B Red curve: boat speeds at different RPMs recorded when you made this fuel consumption curve.
- C Red marker: the boat speed now. This marker is below the red curve, showing that the boat speed now at this RPM is less than when you recorded the curve.
- D Blue curve: fuel consumption at different RPMs recorded when you made this fuel consumption curve.
- E Blue marker: the fuel consumption now. This marker is below the blue curve, showing that the fuel consumption now at this RPM is better than when you recorded the curve.
- F If the blue curve has a dip, then running the boat at this RPM will give the best speed for the least fuel consumption.

7-7 Calibration

Calibrate petrol/gasoline fuel flow sensors during installation, or if the fuel readings seem inaccurate and the other troubleshooting suggestions do not help (see appendix B troubleshooting).

Note

- SmartCraft fuel sensors are factory calibrated and should never need recalibrating.
- On a multi engine boat, calibrate each engine's sensor. This can be done at the same time with a portable tank for each engine or at different times using one portable tank.
- Calibrating a sensor requires accurate measurement of the fuel consumption. This is best done using a small portable tank. At least 4 gallons (15 litres) of fuel should be used to ensure an accurate calibration.
- It is often very difficult to fill underfloor tanks to the same level twice due to air pockets, so the more fuel used, the more accurate the calibration.

To calibrate the sensor(s):

- 1 Record the level of the fuel in the tank(s).
- 2 Connect the portable tank(s) to the engine through the fuel sensor(s).
- 3 Run the engine at normal cruising speed until at least 4 gallons (15 litres) of fuel has been used per engine.
- 4 Check the actual amount of fuel used per engine by refilling the portable tank(s) to the original level and noting the reading(s) of the fuel dispenser's gauge.
- 5 Press **MENU** twice, select **Fuel** then select **Setup engines**.
- 6 On a single engine boat, select **Calibrate** and change the displayed value to be equal to the reading of the fuel dispenser's gauge, then press **ENT**.

On a multi-engine boat select the engine. Select **Calibrate** and change the displayed value to be equal to the reading of the fuel dispenser's gauge, then press **ENT**. Repeat for the other engines.

8 Setting up the 457/467

The 457/467 has a number of advanced features which are set up through the setup menu. We recommend that you become familiar with the operation of the unit using the default settings before making any changes in these menus.

To go to a setup option menu, press **MENU** twice to display the setup menu, then select an option.

Note:

- 1 The Setup menu options are explained in the following sections.
- 2 Section 2-1 describes how to set or change data in the setup menus.
- 3 The setup data available will depend on the optional sensors and instruments installed.



Setup option menus

Factory default settings are shown. The setup data available will depend on the optional sensors and instruments installed.

System (see 8-1)

System	
Language	English
Backlight	15
Night mode	<input type="checkbox"/>
Key beep	<input checked="" type="checkbox"/>
Auto power off	<input type="checkbox"/>
Factory reset	
About	
Sonar	<input checked="" type="checkbox"/>
SmartCraft	<input checked="" type="checkbox"/>

Sonar (see 8-2)

Sonar	
Frequency	200kHz
Scroll speed	Fast
Fish symbols	Off
Fish depth labels	<input type="checkbox"/>
Fish filter	Small
Fish sensitivity	Medium
Digit size	Medium
Palette	White
Interference filter	<input type="checkbox"/>
Noise filter	Off
Surface clutter filter	<input type="checkbox"/>
Pulse length	Auto
Pulse power	Auto

Fuel (see 8-3)

Fuel	
Source	Gasoline
Num engines	1
Num tanks	1
Setup engines	▶
Setup tanks	▶
Diesel sensors	
Fuel consumption curve	▶
Speed source	Ground speed
Max fuel flow	26 G
Max RPM	3000

SmartCraft

(See the *SmartCraft Gateway Installation and Operation Manual*)

Logs (see 8-4)

Logs	
Reset trip dist	
Reset total dist	
Reset engine hours	
Trip dist	0.00 nm
Total dist	0.00 nm
Engine hours	0.0 hrs

Alarms (see 8-5)

Alarms	
Fish	<input type="checkbox"/>
Too shallow	▶
Too deep	▶
Temperature	▶
Temperature rate	▶
Low battery	▶
Fuel	▶

Units (see 8-6)

Units	
Distance	nm
Speed	kn
Depth	ft
Fuel	USGal
Temperature	°F
Wind	TRUE
Pressure	kPa
Baro	mB

Comms (see 8-7)

Comms	
NMEA out	<input type="checkbox"/>
NMEA data	▶
NavBus	<input checked="" type="checkbox"/>
NavBus group	0

Calibrate (see 8-8)

Calibrate	
Speed	
Speed filter	Off
Temperature	
Temp filter	5 sec
Keel offset	0.0 ft
Speed range	Low

Favorites (8-9)

Favorites	
Name	
1	Sonar + Gauges
2	Fuel
3	Data
4	-
5	-
6	-
MENU for options	

Simulate (8-10)

Simulate	
Simulate	<input type="checkbox"/>
Speed	1.0 kn

8-1 Setup > System

Press **MENU** twice, then select **System**:

System	
Language	English
Backlight	15
Night mode	<input type="checkbox"/>
Key beep	<input checked="" type="checkbox"/>
Auto power off	<input type="checkbox"/>
Factory reset	
About	

Sonar	<input checked="" type="checkbox"/>
SmartCraft	<input checked="" type="checkbox"/>

Language

Select the language for the displays.

Tip: In case you can't read the current language, the language setting is found at the top of the system menu.

Backlight

Select the backlight level for the keys and display. See also section 2-3.

Night mode

Night mode sets the palette for all displays.

Normal palette, for daytime

All displays have a palette optimised for night time.

See also section 2-3.

Key beep

Enables or disables the beep when a key is pressed.

Auto power off

See section 2-2.

Snooze Mode

This power saving option slows the sounding rate (time between each ultrasonic pulse) to a user specified interval from 5 minutes to 2 hours. The fishfinder appears to turn off, however all alarms operate normally. To return to normal operation, press Power **(D)** button. Ideal to be used as an anchor alarm.

Factory reset

This option returns all of the 457/467 settings (except the language, waypoints and routes) to the default factory settings shown on the setup menus.

Sonar

Disable any sonar transducer and disable sonar functions. Deselect if the unit is to be used as a SmartCraft only display.

A sonar transducer is fitted. Enable sonar operation.

See section 9-5.

SmartCraft

No SmartCraft gateway is fitted. Disable SmartCraft functions.

SmartCraft gateway is fitted. Enable SmartCraft operation.

See section 9-7.

About

Display the About window.

The about window shows:

- Model
- The software/hardware version information.
- Connector wiring information.

In the unlikely event of having to contact a Northstar dealer for service, quote the software/hardware version number and date.

About	
Copyright © 2004-2006 Northstar	
Model	457
Software	1.0.0, Aug 18 2006
Hardware	0.18.10
Bootloader	1.0.0
SmartCraft	--
Power/comms cable <input type="checkbox"/> Black	
1 <input checked="" type="checkbox"/> Black	Ground
2 <input type="checkbox"/> Brown	Not used
3 <input type="checkbox"/> White	NMEA out
4 <input type="checkbox"/> Blue	NavBus-
5 <input type="checkbox"/> Red	+12/24V in
6 <input type="checkbox"/> Orange	NavBus+
7 <input type="checkbox"/> Yellow	Ignition
8 <input type="checkbox"/> Green	Ext Alarm
Fuel cable <input type="checkbox"/> White	
1 <input checked="" type="checkbox"/> Black	Ground
3 <input type="checkbox"/> White	NMEA in
Sonar cable <input type="checkbox"/> Blue	

Sonar	
Frequency	200kHz
Scroll speed	Fast
Fish symbols	Off
Fish depth labels	<input type="checkbox"/>
Fish filter	Small
Fish sensitivity	Medium
Digit size	Medium
Palette	White
Interference filter	<input type="checkbox"/>
Noise filter	Off
Surface clutter filter	<input type="checkbox"/>
Pulse length	Auto
Pulse power	Auto

Press **MENU** twice, then select **Sonar**:

Frequency

There is a choice of: **200 kHz**, **50 kHz** and **Mixed**. For information about selecting a suitable frequency for the water conditions, see section 3-3.

Scroll speed

Use this to set the scroll speed on the display.

There is a choice of: **Very Fast**, **Fast**, **Medium**, **Slow** and **Pause**. The depth of the water also affects the speed of the display.

Faster scroll speeds combined with a slow boat speed (typically between 2 and 6 knots) shows the most fish detail. **Medium** or **Slow** scroll speeds result in sonar information being displayed over a longer period, but with less detail (see Section 3-2).

Fish symbols

The 457/467 always displays echoes from fish (fish arches, see section 3-4). If fish symbols are on, a symbol is displayed over the arch (see section 3-4). The options are:

- **Off**: No fish symbol is displayed.
- **Fun** or **Normal**: A fish symbol is displayed.

Depth

The depth of the fish is displayed.

Fish filter

Use this to select the minimum fish size that will be displayed as a fish symbol and to trigger the Fish alarm. The options are: **Small**, **Medium** and **Large**.

Fish sensitivity

Selects the minimum strength fish echo that will be displayed as a fish symbol. Higher values will display more fish symbols.

Digit size

Use this to remove or change the size of the depth display on the sonar displays. There is a choice of:

Small, **Medium** and **Large**.

Palette

Use this to select a color palette. Each color within the palette represents a different echo strength, as shown on the sonar displays.

There is a choice of five color palettes: **Black**, **Blue**, **White**, **Vivid** and **8 color**. The first four palettes display more detail, and each color covers a 1.5 dB signal range. The **8 color** palette displays less detail, and each color covers a 3 dB signal range.

Interference filter

- No filter, normal setting.
- Filters the echo signal to remove spiky interference such as engine noise or depth sounders on nearby boats.

Noise filter

Averages the echo signal to remove rapid changes. Select Medium or High to give a smoother bottom trace—this may help to detect a deeper bottom; however these settings may also remove fish echoes. Select Off for best fishfinding.

Surface clutter filter

- No filter.
- Filters the echo signal to reduce false echoes close to the surface.

Pulse length

This can be used to specify the length of the transmitted ultrasonic pulse. A short pulse length improves the display detail but contains less energy, therefore it does not penetrate as deeply into the water as a longer pulse.

There is a choice of **Auto**, **Short**, **Medium** or **Long**. The **Auto** setting is recommended.

Pulse power

This can be used to specify the power output of the transmitted ultrasonic pulse. Low power output conserves the battery and produces a clear display in shallow water.

There is a choice of **Auto**, **Low**, **Medium** or **High**. The **Auto** setting is recommended.

⚠ WARNING

Care must be taken when altering the pulse length and pulse power settings. Incorrect use could lead to a loss of depth readings in some circumstances.

8-3 Setup > Fuel

⚠ WARNING

Fuel consumption can change drastically depending upon the boat loading and the sea conditions. Always carry adequate fuel for the journey, plus a reserve.

Fuel functions require optional fuel flow sensors to be installed. Press **MENU** twice, then select Fuel:

Fuel	
Source	Gasoline
Num engines	1
Num tanks	1
Setup engines	▶
Setup tanks	▶
Diesel sensors	
Fuel consumption curve	▶
Speed source	Ground speed
Max fuel flow	26 G
Max RPM	3000

Source

Select the fuel flow sensors to use if the boat has more than one set of fuel sensors. Normally select **Auto**.

Num engines

Set the number of engines, or select **0** to disable the fuel functions. If there are two engines they are called port and starboard.

Num tanks

Set the number of fuel tanks. If there are two tanks they are called port and starboard.

Setup engines

If the boat has more than one engine, select Engine and select each engine in turn.

For the selected engine, you can enter:

Setup engines	
Engine	Single
From tank	Single
Calibrate	
Flow filter	5
Clear used	
Used	0.0 G

From tank: The fuel tank the engine is connected to.

Flow filter: Most engines do not draw fuel from the tank at a steady rate. To give a stable fuel flow reading, the instrument calculates the flow by taking several measurements and averaging them. Use the Flow filter to set the period over which the fuel flow is averaged.

The Flow filter can be set from 0 to 30 seconds. Use the lowest value which gives a stable flow. Usually a value of 5 to 10 seconds will give a satisfactory result for two-stroke carburettor engines. Fuel injected or four-stroke engines may require a larger value.

This setting affects the Fuel flow and Fuel economy reading on the Fuel window but it does not affect the Fuel used reading.

Setup tanks

If the boat has more than one tank, select Tank and select each tank in turn.

For the selected tank, you can enter:

Setup tanks	
Tank	Single
Add fuel	
Fill tank	
Set remaining	0 G
Tank alarm	<input type="checkbox"/>
Tank alarm	Off
Tank size	0 G

Add fuel, Fill tank, Set remaining:

See section 7-3.

Tank alarm: See section 7-4.

Tank size: The tank capacity. Northstar recommends measuring tank size by draining the fuel tank, filling it to capacity and using the fuel dispenser's reading. Beware of air pockets, especially in underfloor tanks.

Fuel consumption curve

See section 7-6.

Speed source

If both water speed and ground speed are available, select which to use for fuel calculations (see section 7-5-1).

Max fuel flow

The maximum fuel flow from a fuel tank to be displayed on an analog fuel flow gauge (see section 5)

8-4 Setup > Logs

Press **MENU** twice, then select **Logs**:

Logs	
Reset trip dist	
Reset total dist	
Reset engine hours	
Trip dist	0.00 nm
Total dist	0.00 nm
Engine hours	0.0 hrs

The values can be reset independently of each other. These log values are saved when the unit is turned off.

Reset trip dist

This resets the trip distance to zero.

Reset total dist

This option resets the total distance to zero.

Reset engine hours

Use this option to reset the engine hours to zero. This can be useful after an engine service or to count the engine hours between service intervals.

8-5 Setup > Alarms



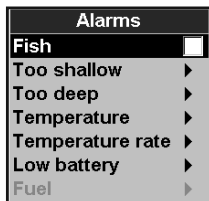



Press **MENU** twice, then select **Alarms**:



For the **Fish** alarm, select to turn the alarm on or select to turn the alarm off. For the other alarms, select **Enabled** from the submenu and enter a trigger value to turn the alarm on.

The alarm will sound each time the alarm value passes the trigger value. For example, the shallow alarm sounds if the depth is less than the trigger value.

Icons for alarms that are on can be displayed in the data header (see section 2-6-1). An alarm icon is normally black and turns red when the alarm sounds.

Symbol	Alarm	Alarm sounds when it is on and the:
	Too shallow	Depth is less than the alarm trigger value
	Too deep	Depth is greater than the alarm trigger value
	Fish	Echo matches the profile of a fish
	Temperature	Temperature equals the alarm trigger value
	Temperature rate	Rate of change of temperature equals the alarm trigger value
	Low battery	Battery voltage is less than the alarm trigger value
	Low fuel	Low fuel remaining equals the alarm trigger value; on a multi-tank boat you can set separate alarms for each tank (see section 7-4)

8-6 Setup > Units

Press **MENU** twice, then select **Units**:

Units	
Distance	nm
Speed	kn
Depth	ft
Fuel	USGal
Temperature	°F
Wind	TRUE
Pressure	kPa
Baro	mB

The default units are shown above.

Distance

nm (nautical miles), mi (miles) or km (kilometres)

Speed

kn (knots), mph (miles per hour) or kph (kilometres per hour)

Depth

ft (feet), m (metres) or fa (fathoms)

8-7 Setup > Comms

Use this feature when the 457/467 is connected to other Northstar instruments through NavBus or any compatible NMEA instrument.

Press **MENU** twice, then select **Comms**:

Comms	
NMEA out	<input type="checkbox"/>
NMEA data	<input type="checkbox"/>
NavBus	<input checked="" type="checkbox"/>
NavBus group	0

NMEA out

NMEA is generally used with third party instruments (see section 9-9). Select this to transmit NMEA sentences.

NMEA data

Use this to specify which NMEA sentences will be transmitted (see section 9-9 and Appendix A).

Fuel

Litres, USGal (US gallons) or ImpGal (Imperial Gallons)

Temperature

°F (Fahrenheit) or °C (Celsius)

Wind (optional)

Requires a wind instrument: True or App (Apparent)

Note: that the units for wind speed are the speed units.

Pressure

Requires SmartCraft: kPa or psi

Baro (Barometric pressure)

Requires a Northstar VHF receiver with barometer connected by NavBus: inHg or mB.

NavBus

NavBus is the preferred method for connecting the 457/467 to other Northstar instruments. Select this if the instruments are connected using NavBus.

NavBus Group

Use this when a group of Northstar instruments are connected together using NavBus, to specify a group of instruments for backlighting, if required. Then, if the backlight setting on one instrument in the group is adjusted, the other instruments change automatically. Otherwise, select **0**. See section 9-8.

8-8 Setup > Calibrate

Press **MENU** twice, then select Calibrate:

Calibrate	
Speed	
Speed filter	Off
Temperature	
Temp filter	5 sec
Keel offset	0.0 ft
Speed range	Low

Speed

This calibrates the speed from a paddlewheel sensor connected to the Instrument. Calibration may be required because different hull shapes have different flow characteristics. Obtain an accurate measurement of the boat's speed from a GPS receiver; or by following another boat travelling at a known speed; or by making a timed run over a known distance.

Note: for accurate calibration:

- The speed from a GPS receiver should be greater than 5 knots.
- The speed from another paddlewheel transducer should be between 5 and 20 knots.
- Best results are achieved in calm conditions where there is minimal current (best at high or low tide).

Calibrating speed:

- 1 Travel at a constant, known speed.
- 2 In the Calibrate menu, select Speed.
- 3 Press **◀** or **▶** to change the displayed speed to the true value.
- 4 Press **ENT**.

Speed filter

Waves and wind cause the boat speed from the paddlewheel transducer to fluctuate slightly. To give stable readings, the Instrument calculates these values by taking several measurements and averaging them. Set the Speed filter to the lowest value which gives stable readings. The range is 1 to 30 seconds or Off (0).

Temperature

The factory settings should be sufficiently accurate for normal usage. To calibrate the temperature readout, first measure the water temperature with a thermometer known to be accurate.

Use the cursor keys to display the temperature readout box, then increase or decrease the value to match the measured temperature. The temperature can be set from 32° to 99.9°F (0° to 37.7°C) with a resolution of 0.1° unit.

To change the units between °F (Fahrenheit) or °C (Celsius), see section 8-6.

Temperature filter

Water turbulence and currents cause the water temperature to fluctuate slightly. To give stable readings, the Instrument calculates these values by taking several measurements and averaging them. Set the Temperature filter to the lowest value which gives stable readings. The range is 1 to 30 seconds or Off (0).

Keel Offset

A depth transducer measures depths below where the transducer is mounted on the boat, usually the bottom of the boat. The Instrument calculates the depths to display by adding the keel offset to all measured depths.

- A Have a zero keel offset to display depths below the transducer.
- B Enter a positive keel offset to increase the displayed depth. For example to display the total depths below the surface, enter the depth of the transducer below the surface.
- C Enter a negative keel offset to decrease the displayed depth. For example, to display the depths of clear water below the boat, enter minus the depth of the deepest part of the boat below the transducer.

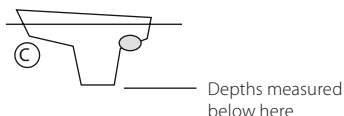
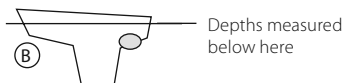
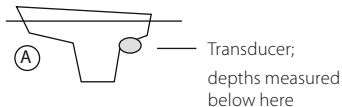

Speed range

The maximum reading to display on an analog boat speed gauge (see section 5). Choose a range suitable for your boat.

Fuel

See section 7-7, Calibrate.

8-9 Setup > Favorites

Favorites	
Name	
1	Sonar + Gauges
2	Fuel
3	Data
4	-
5	-
6	-
 for options	

See section 2-6-2.

8-10 Setup > Simulate

Simulate mode is a way of becoming familiar with the 457/467 (see section 2-5).

Press  twice, then select **Simulate**:

Simulate	
Simulate	<input type="checkbox"/>
Speed	1.0 kn

Turn simulate mode off

Turn simulate mode on

Speed: The simulated boat speed to use.

WARNING









Never have simulate mode on when the 457/467 is on the water.

9 Installation

Correct installation is critical to the performance of the unit. It is vital to read the entire installation section of this manual and the documentation

that comes with the antenna and any other units before starting installation.

9-1 Installation: What comes with the 457/467

457/467 display unit, with a holder for plug-in cards and blanking cap for fuel connector.	
Dust cover for display unit	
Power cable	
Mounting bracket (screws included)	
Warranty registration card	
Flush mounting kit	
Dual frequency sonar transducer (includes cable kit and screws)	
Transom Mount Transducer Installation Manual	
Full Instruction Manual CD*	

9-2 Installation: Options and Accessories

- Replacement paddle wheel
- Northstar carry bag.
- Northstar NavBus junction boxes simplify wiring, particularly if several instruments are connected. For more information, see the *NavBus Installation Manual*.

Optional sensors and instruments

External alarms: Lights or sounders in the boat to sound alarms through the boat (see section 9-4).

Fuel sensors: For fuel functions. The 457/467 can use these optional fuel flow sensors, fitted to one or two engines:

- Northstar petrol/gasoline sensors (see section 9-6)

Engine types supported:

Outboard carburetted two stroke and EFI petrol/gasoline engines: 50 to 300 hp.

Outboard four stroke petrol/gasoline engines: 90 to 300 hp.

Inboard petrol/gasoline engines: 70 to 400 hp.

Flow rate (per engine):

Minimum: 5 litres per hour (1.3 U.S. gallons per hour).

Maximum: 130 litres per hour (34 U.S. gallons per hour).

- SmartCraft fuel sensors (see section 9-7)

SmartCraft: With one or two SmartCraft capable Mercury petrol/gasoline engines, the 457/467 can display engine data and trim and can control trottle speed (see section 9-7).

Other instruments: The 457/467 can receive data from other instruments and send data to other instruments by NavBus or NMEA (see sections 9-8 and 9-9).

Please consult your Northstar dealer for more information.

Connections

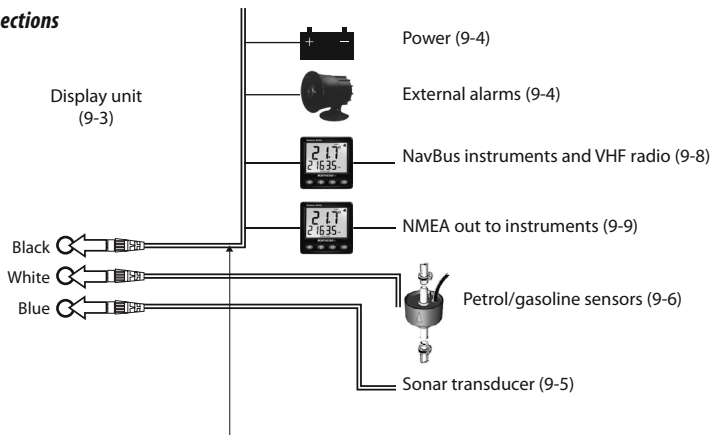

Power/data cable

Pin	Wire	Function
1	Black	Ground: - power in, NMEA ground. (The cable has two black wires which are connected inside the cable and it does not matter which black wire you use)
2	Brown	Not used
3	White	NMEA out
4	Blue	NavBus-
5	Red	Power in, +10.5 to +30.5 V DC
6	Orange	NavBus+
7	Yellow	Auto power in
8	Green	External alarm out, 30 V DC 200 mA maximum.

9-3 Installation: The display unit

Select a position for the display unit:

- At least 4" (100 mm) away from the compass, at least 12" (300 mm) away from any radio transmitter and at least 4 ft (1.2 m) away from any antenna.
 - Easy to read and operate. If possible, mount the display unit in front of the navigator or to the right of the navigator because the LCD display is more readable from these positions.
- Not exposed to the direct sun or water and protected from physical damage during rough sea passages.
 - Easy to access the power source and convenient to route the transducer cables.

There are two mounting arrangements:

1 Flush Mounting

Requires a solid panel with access behind for wiring and mounting screws. After flush mounting, the display unit cannot be tilted or moved after installation to reduce any unwanted glare or reflections. Carefully select the best viewing position before installation. This would generally be in a shaded area.

- 1 Cut a hole in the bulkhead for the display unit using the flush mount template.
- 2 Drill four holes for the mounting studs using the flush mount template.
- 3 Screw the four studs into the brass inserts in the back of the display unit.
- 4 Sit the display unit in place and fit the washers and nuts to the studs.

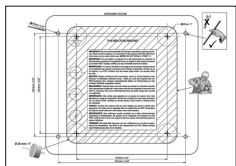

2 Bracket Mounting

Requires a panel for mounting the bracket. Ensure that the panel is not likely to deform and is not subject to excessive vibration. The bracket can be tilted and rotated. The display unit can be removed when it is not in use.

- 1 Hold the bracket in place and mark the screw holes.
- 2 Drill the screw holes and screw the bracket in place. Do not overtighten the screws or the display unit might not rotate.
- 3 Hold the display unit in place on the mounting bracket shaft. Hand tighten the knob on the mounting bracket.



9-4 Installation: Power/data cable

The power/data cable has a black locking collar and flying leads.

- 1 Wire the 457/467 for auto power to have the 457/467 turn on with the boat's ignition switch or to record engine hours or if the 457/467 must add up the total fuel used (for example if Northstar petrol/gasoline fuel sensors are installed or if SmartCraft is installed without fuel tank level sensors). Otherwise wire for basic power (for more information, see section 2-2).

Basic power

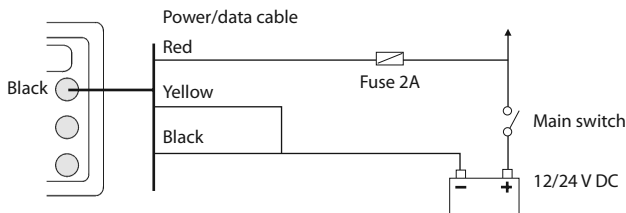

Auto power

During setup, set up **Auto power off** (see sections 2-2 and 8-1)

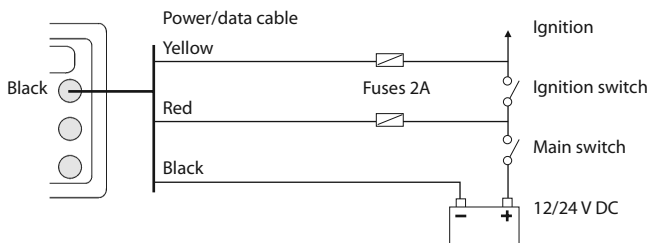

- 2 Wire any external alarm beepers or lights. The alarm output switches to ground to sound the alarm. If the current is more than 200 mA, fit a relay.
- 3 Connect the power/data cable to the black display unit connector; turn the collar to lock the connector.

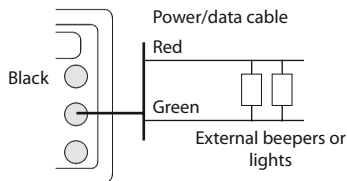

9-5 Installation: Sonar transducer

Either:

- Fit the transom mount sonar transducer supplied, following the instructions in the Transom Mount Transducer Installation Manual supplied with the 457/467.
- For enhanced performance, fit an optional through hull dual frequency sonar transducer and through hull speed/temperature transducer. Contact the nearest Northstar dealer for more information.

Connect the transducer to the blue 457/467 connector; tighten the locking collar.

During setup

- a set **Sonar** to (see section 8-1).
- b set up the sonar options (see section 8-2).

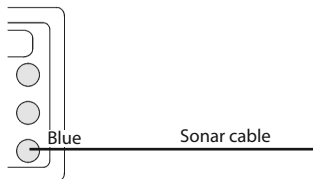

9-6 Installation: Northstar petrol/gasoline sensors

Fit the optional petrol/gasoline fuel kit following the instructions supplied with the kit.

Note:

- SmartCraft engines have fuel flow sensors, therefore Northstar fuel sensors are not required as well.
- For dual engines, fit a twin engine kit.
- Wire the 457/467 for auto power (see section 9-4).

During setup set the fuel data (see section 8-3).

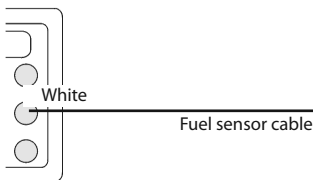

9-7 Installation: SmartCraft

If the boat has one or two SmartCraft capable Mercury petrol/gasoline engines, connect the 457/467 to the SmartCraft engines with an optional SmartCraft gateway. The display unit can display engine data and trim and can control trottle speed.

Note:

- Fit a single gateway for single engines and a dual gateway for dual engines.
- SmartCraft engines have fuel flow sensors, therefore Northstar fuel sensors are not required as well.
- If the fuel tank does not have SmartCraft level sensors, wire for auto power (see section 9-4).

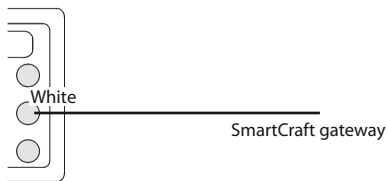

During setup, enter the SmartCraft setup data. For information on installing, setting up and using SmartCraft, see the *SmartCraft Gateways Installation and Operation Manual*.

9-8 Installation: Other NavBus instruments

NavBus is Northstar's system for connecting instruments together to interchange data and share transducers. When instruments are connected by NavBus:

- If the units, alarms or calibration are changed in one instrument, then the values will automatically change in all other instruments of the same type.
- Each instrument can be assigned to a group of instruments. If the backlight is changed in an instrument in group 1, 2, 3 or 4 then the backlight will automatically change in the other instruments in the same group. If the backlight is changed in an instrument in group 0 then no other instruments are affected.
- If an alarm sounds, mute it by clearing the alarm on any instrument which can display that alarm.

NavBus and the 457/467

The 457/467 can:

- Display wind speed and direction from an optional Northstar Wind instrument
- Receive data from an optional Northstar VHF radio (with NavBus functionality). The 457/467 can display:

Baro: barometric pressure

Baro history: barometer history

Weather: a predication, based on changes in barometric pressure

Fish forecaster: a prediction based on changes in barometric pressure

- Send data to optional Northstar instruments, for example to a repeater.
- Receive and display GPS speed from a GPS receiver
- Display fuel data from a fuel transducer attached to another Northstar instrument

During setup for NavBus instruments, set

NavBus to and assign the instrument a **NavBus group** number (see section 8-7)

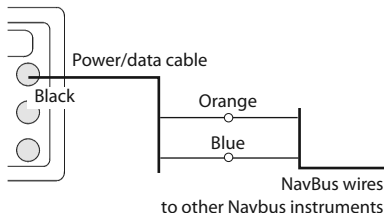

9-8-1 Installation: Northstar VHF radio

Fit and set up the optional Northstar VHF radio (with NavBus functionality) following the instructions supplied with the radio.

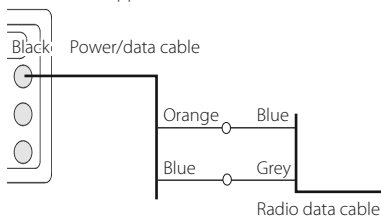

9-9 Installation: Other NMEA instruments

NMEA is an industry standard for interconnecting instruments. It is not as flexible or as easy to install as NavBus.

The 457/467 can send depth, speed and temperature to other instruments.

During setup to send NMEA data to other instruments, set **NMEA out** to and specify the **NMEA data** to send (see section 8-7).

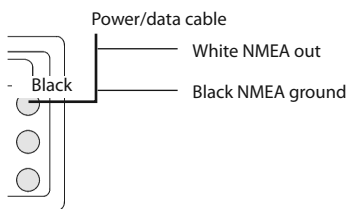

9-1 Installation: Setup and test

Setup and test

- 1 Put a blanking cap on any unused connector on the back of the display unit. Ensure all connectors are plugged in and the display unit is in place.
- 2 If the display unit is bracket mounted, adjust tilt and rotation for best viewing and hand tighten the knob.
- 4 Turn the instrument on (see section 2-2). When the 457/467 is turned on for the first time, it displays an installation menu:
 - i Select the language to use.
 - ii Change the data if necessary (see section 2-1)
 - iii When the setup data is correct, press .
- 5 Enter setup data to set up the 457/467 to your requirements and to set up any optional sensors or instruments (see section 8).

This data can be changed later (see section 8).

Appendix A - Specifications

GENERAL

Size:

- 457:
5.9" H x 6.5" W x 2.6" D
(150 mm H x 164 mm W x 65 mm D)
- 467:
7" H x 7.7" W x 2.1" D
(179 mm H x 195 mm W x 54 mm D)

Display:

- 457: 5" diagonal, TFT color, 480 x 640 pixels
- 467: 6.4" diagonal, TFT color, 480 x 640 pixels

Backlight: Display and keys

Supply voltage

11 V to 30.5 V DC.

Supply current:

 at 13.8 V

350 mA min - no backlighting.

1A max - full backlighting.]

External beeper or light output: Switched to ground to sound alarm, 30 V DC, 200 mA maximum.

Operating temperature

0°C to 50°C (32° to 122°F)

ALARMS:

- User set: Too shallow, too deep, fish, temperature, temperature rate, low battery, low fuel (optional)

SONAR FISHFINDING

Depth range:

0.6 m (2 ft) to 1000 m (3300 ft)

Sonar output:

- Power: Variable, up to 600 W RMS
- Dual frequency: 50 kHz and 200 kHz

Transom transducer cable length:

10 m (33 ft) + extensions available

Depth acquisition time from startup:

Typically 2 seconds at 30 m (100 ft)

Temperature:

- Range 0° to 37.7°C (32° to 99.9°F)
- Resolution of 0.1° unit.

Speed (from paddlewheel transducer):

1 kph to 96.6 kph (57.5 mph, 50 kn).

COMMUNICATIONS

NavBus

Connection to other Northstar instruments.

NMEA

NMEA 0183 ver 2 4800 baud

- Outputs, for compatible instruments: DBT, DPT, MTW, VHW, VLW, XDR

STANDARDS COMPLIANCE

EMC:

- USA: FCC Part 15 Class B.
- Europe: (CE) EN301843-1:2004-06
- New Zealand and Australia: (C Tick) EN60945 9.2 & 9.3

Environment: IPx6/IPx7/CFR46 (with connections in place)

FISH 457

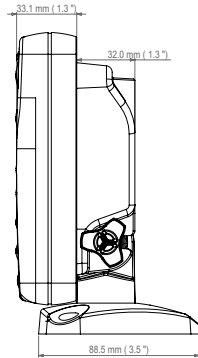
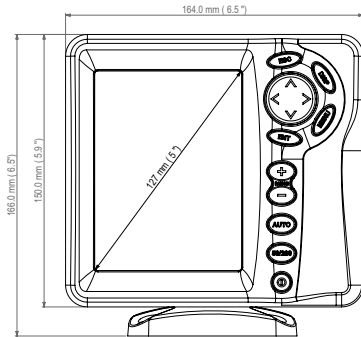

FISH 467

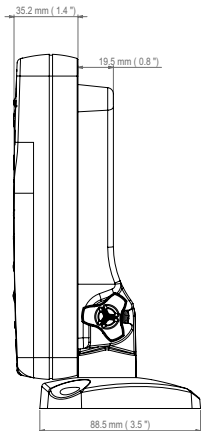
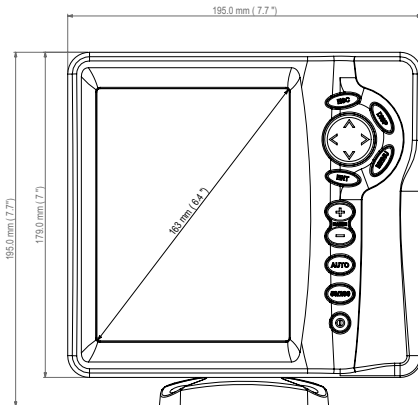

Appendix B - Troubleshooting

This troubleshooting guide is written with the assumption that the user has read and understood the relevant sections in this manual.

It is possible in many cases to solve difficulties without having to send the display unit back to the manufacturer for repair. Please follow this troubleshooting section before contacting the nearest Northstar dealer.

There are no user serviceable parts. Specialized methods and testing equipment are required to ensure that the display unit is reassembled

correctly and is waterproof. Users who service the product themselves will void the warranty.

Repairs to the product may only be carried out by a service center approved by Northstar. If the product must be sent into a service center for repair, it is essential to send in the transducer(s) at the same time.

More information can be found on our website: www.northstarnav.com.

B-1 General problems

1-1 The 457/467 won't turn on:

- a The 457/467 is designed to operate on a 12/24 V DC battery system, where the voltage may vary from +10.5 V to 30.5 V DC. If an excessive voltage is supplied, a fuse will be tripped, turning the display unit off. Check the fuse.
- b Check that the power cable connector at the back of the display unit is securely plugged in and the collar is locked in place. The collar must be secure for watertight connection.
- c Measure the battery voltage while the battery is under load - turn on some lights, radio or other electrical equipment connected to the battery. If the voltage is less than 10 volts:
 - the battery terminals or wiring on the terminals may be corroded.
 - the battery may not be charging correctly or may need replacing.
- d Inspect the power cable from end to end for damage such as cuts, breaks, squashed or trapped sections.
- e Check power wiring (see section 9-4).
- f Check for corrosion on the power cable connector and clean or replace if required.
- g Check fuses that are placed in line with the power cable. A fuse can be blown despite appearing to be good or the fuse may be corroded. Test the fuse or replace it with a fuse known to be good.

1-2 The 457/467 won't turn off:

The 457/467 may have been wired for Auto power. In this case, the 457/467 cannot be turned off while the ignition power is on (see section 2-2).

1-3 If the 457/467 beeps when turned on but nothing is displayed:

The 457/467 may be operating, but the backlight settings may have been set too low (see section 2-3).

1-4 The wrong language is displayed:

See section 8-1.

B-2 Fuel consumption problems

2-1 Number of engines or tanks is wrong

Check that the number of engines and tanks is correct (see section 8-3).

2-2 Fuel flow(s) seem inaccurate:

- a Check that the fuel setup data is correct (see section 8-3).
- b Check that the fuel cable connectors are securely plugged in and the collar is locked in place. Check the fuel cable is not damaged or pinched.
- c A fuel sensor may be blocked. A fuel filter must be installed between the fuel transducer and the fuel tank as described in the sensor installation manual. Otherwise the warranty is void.
- d Recalibrate the fuel flow sensor(s) (see section 7-7).
- e Check that the fuel filter is clean.
- f In rough seas, fuel may surge back and forth through the fuel sensor(s), resulting in incorrect readings. Try installing a one-way valve between the fuel sensor(s) and the fuel tank.
- g Petrol/gasoline fuel sensors should be replaced as necessary.

2-3 Fuel remaining seems inaccurate:

- a The 457/467 is not wired for auto power (see section 9-4).
- b You added or removed fuel but did not tell the 457/467 (see section 7-3).
- c The fuel tank may not refill to the same capacity each time due to air pockets. This is a particular problem with underfloor tanks.

2-4 Erratic fuel flow readings:

- a The Flow filter value is not suitable for the engine. Check that the value is not set to zero, then try increasing the value until a steady flow rate is shown (see section 8-3).
- b The fuel flow sensor(s) may be too close to the fuel pump or may be subject to excessive vibration. Refer to the fuel sensor installation manual.
- c Check for leaks in the fuel line or in the fuel pickup in the tank.

2-5 There is no reading for fuel economy:

- a The boat must be travelling through the water to have a reading.
- b If you selected a paddlewheel sensor (see section 8-3), check that the paddlewheel spins freely.

3-1 The 457/467 operates erratically:

- a Check that the transducer does not have debris (e.g. weed, plastic bag) caught around it.
- b The transducer may have been damaged during launching, running aground or while underway with debris etc. If the transducer has been impacted, it may have been kicked up on the bracket. If it is not physically damaged, reset the transducer back to its original position. (See the *Transom Transducer Installation Guide*.)
- c When the transducer is less than 2 ft (0.6 m) from the bottom, the depth readings may become inconsistent and erratic.
- d Manual Gain may be set too low, which may cause weak bottom echo or no fish signals. If in Manual Gain, try increasing the Gain.
- e Ensure the back of the bottom surface of the transducer is slightly lower than the front and the front is as deep in the water as possible in order to minimize the generation of bubbles through cavitation. (See the *Transom Transducers Installation Guide*.)
- f Check the transducer and power cable connectors at the back of the display unit are securely plugged in and the collars are locked in place. The collars must be secure for watertight connection.
- g Inspect the power cable from end to end for damage such as cuts, breaks, squashed or trapped sections.
- h Ensure there is not another fishfinder or depth sounder turned on, which may interfere with this 457/467.
- i Electrical noise from the boat's engine or an accessory may be interfering with the transducer(s) and/or the 457/467. This may cause the 457/467 to automatically decrease the Gain unless using Manual Gain.

The 457/467 thus eliminates weaker signals such as fish or even the bottom from the display. This may be checked by switching off other instruments, accessories (e.g. bilge pump) and the motor until the offending device is located. To stop problems from electrical noise, try:

- re-routing the power and transducer cable(s) away from the boat's other electrical wiring.
- routing the display unit's power cable directly to the battery with an in-line fuse.

3-2 Bottom is not displayed:

- a The 457/467 may have Manual Range selected and the depth may be outside the range value selected. Either change the 457/467 to Auto Range or select another depth range (see section 3-5).
- b The depth may be outside the 457/467's range. While in Auto Range, the display unit will display "--" to indicate that there is no bottom detected. A display of the bottom should reappear when in shallower water.

3-3 The bottom is displayed too far up the screen:

The 457/467 may have Manual Range selected and the selected Range value is too high for the depth. Either change the 457/467 to Auto Range or select another depth range (see section 3-5)

3-4 Bottom echo disappears or erratic digital reading while the boat is moving:

- a Ensure the back of the bottom surface of the transducer is slightly lower than the front and the front is as deep in the water as possible in order to minimise the generation of bubbles through cavitation. (See the *Transom Transducers Installation Guide*, for more information.)

- b The transducer may be in turbulent water. Air bubbles in the water disrupt the echoes returned, interfering with the 457/467's ability to find the bottom or other targets. This often happens when the boat is reversed. The transducer must be mounted in a smooth flow of water in order for the 457/467 to work at all boat speeds.
 - c Electrical noise from the boat's motor can interfere with the 457/467. Try some suppression spark plugs.
- 3-5 There is a double bottom trace displayed:**
 - a The boat may be in an area that generates shadows (see section 3-2).
 - b In shallow water, the echoes may bounce. Reduce the gain setting (see section 3-6) and/or reduce the sonar pulse power (see section 8-2).
 - c Decrease the Range.

Appendix C - Glossary and navigation data

Glossary

NavBus - A way of connecting Northstar instruments together to share data (see section 9-8).

NMEA - National Marine Electronics Association.

NMEA 0183 - A standard for interfacing marine electronic devices (see section 9-9).

SBN II- Signal enhancement Bottom recognition Noise rejection.

SmartCraft - A feature of Mercury Marine engines for monitoring engine performance.

AMERICAS

30 Sudbury Road,
Acton, MA 01720, USA
Ph: +1 978.897.6600
Ph: +1 800.628.4487
Fax: +1 978.897.7241
sales@bntmarine.com

EUROPE

Unit 2, Ocean Quay,
Belvidere Rd, Southampton,
SO14 5QY, ENGLAND
Ph: +44 2380 339922
Fax: +44 2380 330345
northstaruk@northstarnav.com

AUSTRALIA

PO Box 479,
Gladesville, NSW 2111,
AUSTRALIA
Ph: +61 2 9879 9060
Fax: +61 2 9879 9009
northstaraus@northstarnav.com

NEW ZEALAND

PO Box 68 155,
Newton, Auckland
Auckland, NEW ZEALAND
Ph: +64 9 481 0500
Fax: +64 9 481 0590
northstarnz@northstarnav.com

www.northstarnav.com

NORTHSTAR 



Made in New Zealand
MN000659A-G