

SportPilot and SportPilot Plus

Owner's Handbook

Document number: 81057-5
Date: May 2001

Autohelm, HSB (High Speed Bus), SailPilot, SeaTalk and SportPilot are registered trademarks of Raymarine Ltd.

Raymarine, AST (Advanced Steering Technology), AutoAdapt, AutoLearn, AutoRelease, AutoSeastate, AutoTack, AutoTrim, FastTrim, GyroPlus, RayGyro, RayPilot and WindTrim are trademarks of Raymarine Ltd.

Handbook contents © Raymarine Ltd 2001.

Contents

Chapter 1: Introduction	1
About this handbook	3
Important Information	3
Chapter 2: Operating the SportPilot	9
2.1 Switching on and off	9
Switching on	9
Switching off	9
2.2 Basic operation	9
Engaging and disengaging the pilot	9
Making course changes	10
Adjusting autopilot gain	11
2.3 Using Navigator (Track) mode	12
Chapter 3: Maintenance & Fault Finding	15
3.1 General maintenance	15
3.2 Fault finding	16
3.3 Product support	16
Chapter 4: Installing the SportPilot	19
4.1 Planning the installation	20
Installation instructions	21
4.2 Installing the compass	23
Compass location	23
Compass mounting	24
Compass cabling	24
4.3 Installing the rudder position sensor – optional	26
Linear rudder position sensor – installation (hydraulic outboard steering systems)	26
Rotary rudder position sensor – installation (hydraulic inboard steering systems)	29
4.4 Providing power for the SportPilot	37
Interfacing with NMEA equipment	38
4.5 Connecting SeaTalk equipment	39
Typical SeaTalk connections	40
4.6 Installing the SportPilot	41
Step 1 – Remove the steering wheel	41
Step 2 – Mount the torque bracket	42
Step 3 – Plug the cables into the SportPilot	45
Step 4 – Assemble and secure the SportPilot	47

Chapter 5: Compass Calibration 51

 Important note 51

 Introduction 51

 5.1 Compass linearization and heading alignment 52

 5.2 Heading alignment without linearizing 54

Index 55

Chapter 1: Introduction

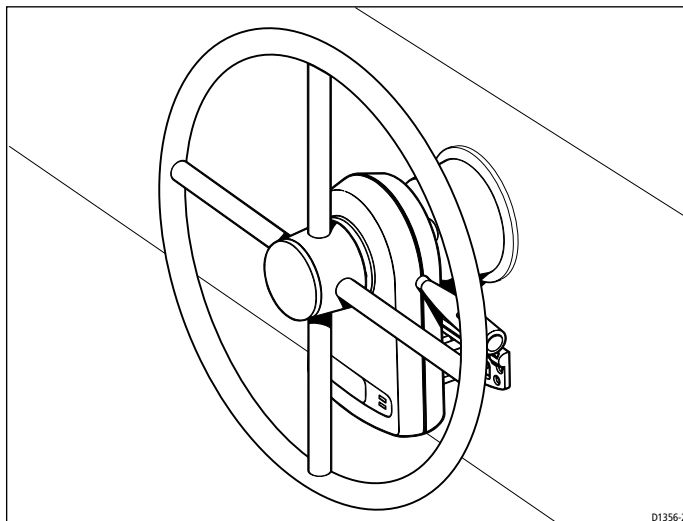

Congratulations on the purchase of your Raymarine SportPilot.

The SportPilot fits neatly over the steering column directly behind the steering wheel. All of the autopilot controls are located on a rotary switch at the end of a control stalk. These controls consist of:

- Standby mode (**STANDBY**)
- five autopilot settings (**LO** to **HI**) to control the amount of rudder applied when course changes are made
- Navigator (or Track) mode (**NAV**) for tracking to waypoints when the SportPilot is used with a chartplotter or GPS

The SportPilot is very easy to use:

- simply point the boat in the direction you want to go, turn the rotary control switch to one of the autopilot settings (**LO** to **HI**) and release the wheel – *it really is that simple*
- if you want to change course under autopilot control, simply turn the boat onto the new heading and once again let go of the wheel – *you don't even have to disengage the autopilot*

If you have a SeaTalk or NMEA position sensor, navigation to favorite fishing grounds or wrecks is a breeze. Cross track error information is constantly fed to the autopilot so that your heading is continuously updated.

The SportPilot can also be operated away from the steering station, using a hand-held remote control or a Raymarine fixed control unit.

The SportPilot is designed to be owner installed, and most of the necessary tools are supplied.

SportPilot and SportPilot Plus specifications

There are two versions of the SportPilot: the SportPilot and the SportPilot Plus. It is vital to use the appropriate pilot for your boat. The SportPilot will not perform effectively if you exceed the following boat compatibility specifications.

General specifications

Nominal supply voltage:	12 V DC
Dimensions:	Height: 220 mm (8.7 in) Width: 238.5 mm (9.4 in) including stalk 137.5 mm (5.4 in) excluding stalk Depth: 100.5 mm (4.0 in)
Heading reference:	Raymarine fluxgate compass
Operating modes:	<ul style="list-style-type: none"> • Standby (autopilot not active) • Auto (autopilot operating): with five settings to control autopilot rudder gain. • Navigation (Track) mode: autopilot following waypoints received from navigator.
Inputs/Outputs:	Compass, Rudder Position Sensor, Power/NMEA 0183, SeaTalk
Steering shaft size:	19 mm ($\frac{3}{4}$ in) and 25 mm (1 in) tapered

SportPilot – boat compatibility

Maximum displacement:	2000 kg (4400 lbs) manual cable steering 3500 kg (7700 lbs) manual hydraulic steering 3500 kg (7700 lbs) servo hydraulic steering
Maximum wheel diameter: (depending on weight)	54 cm (21 in) wooden 46 cm (18 in) metal

SportPilot Plus – boat compatibility

The SportPilot Plus has a more powerful motor designed specifically for boats where the autopilot is used for hours at a time on a daily basis.

About this handbook

This handbook contains two main parts:

Part 1: Using the SportPilot

This part of the handbook explains how to use your SportPilot:

2	Chapter 2: Operating the SportPilot Explains how to use the SportPilot.	page 9
3	Chapter 3: Maintenance & Fault Finding Provides maintenance and fault finding information.	page 15

Part 2: Installing the SportPilot

This part of the handbook explains how to install your SportPilot:

4	Chapter 4: Installing the SportPilot Explains how to install your SportPilot and its components.	page 19
5	Chapter 5: Compass Calibration Explains how to linearize the SportPilot compass and align its heading.	page 51

Note: This handbook contains important information about installing, using and maintaining your new Raymarine product. To get the best from the product, please read this handbook thoroughly.

Important Information

Warranty

To register your new Raymarine product, please take a few minutes to fill out the warranty card. It is important that you complete the owner information and return the card to us to receive full warranty benefits.

Handbook information

To the best of our knowledge, the information in this handbook was correct when it went to press. However, Raymarine cannot accept liability for any inaccuracies or omissions it may contain. In addition, our policy of continuous product improvement may change specifications without notice. As a result, Raymarine cannot accept liability for any differences between the product and the handbook.

Safety notices

WARNING: Product installation

This equipment must be installed and operated in accordance with the instructions contained in this handbook. Failure to do so could result in poor product performance, personal injury and/or damage to your boat.

WARNING: Electrical safety

Make sure the power supply is switched off before you make any electrical connections.

WARNING: Navigation aid

Although we have designed this product to be accurate and reliable, many factors can affect its performance. As a result, it should only be used as an aid to navigation and should never replace common sense and navigational judgement. Always maintain a permanent watch so you can respond to situations as they develop.

Your Raymarine autopilot will add a new dimension to your boating enjoyment. However, it is the skipper's responsibility to ensure the safety of the boat at all times by following these basic rules:

- Ensure that someone is present at the helm **AT ALL TIMES**, to take manual control in an emergency.
- Make sure that all crew members know how to disengage the autopilot.
- Regularly check for other boats and any obstacles to navigation – no matter how clear the sea may appear, a dangerous situation can develop rapidly.
- Maintain an accurate record of the boat's position by using either a navigation aid or visual bearings.
- Maintain a continuous plot of your boat's position on a current chart. Ensure that the locked autopilot heading will steer the boat clear of all obstacles. Make proper allowance for tidal set – the autopilot cannot.
- Even when your autopilot is locked onto the desired track using a navigation aid, always maintain a log and make regular positional plots. Navigation signals can produce significant errors under some circumstances and the autopilot will not be able to detect these errors.

EMC conformance

All Raymarine equipment and accessories are designed to the best industry standards for use in the recreational marine environment. The design and manufacture of Raymarine equipment and accessories conform to the appropriate Electromagnetic Compatibility (EMC) standards, but correct installation is required to ensure that performance is not compromised.

Part 1: Using the SportPilot

Part 1: Using the SportPilot

Chapter 2: Operating the SportPilot

2.1 Switching on and off

Switching on

The SportPilot enters Standby mode when the power supply is switched on. This mode is identified by the flashing red **AUTO** LED. As soon as the pilot is engaged (see below), the red LED glows permanently to confirm this selection.

Switching off

Switching off your boat's power supply will switch off the SportPilot. **To prevent the SportPilot draining the battery, always switch off the power supply when leaving the boat for long periods.**

2.2 Basic operation

Engaging and disengaging the pilot

Engaging the pilot

1. Steer the boat onto the required heading.
2. Turn the rotary control switch clockwise from **STANDBY** to one of the five autopilot gain settings (**LO** to **HI**).

Note: It is important to select the correct gain setting for your boat's speed. See *page 11* for details.

3. Release the wheel – there will be a short delay before the pilot takes control.

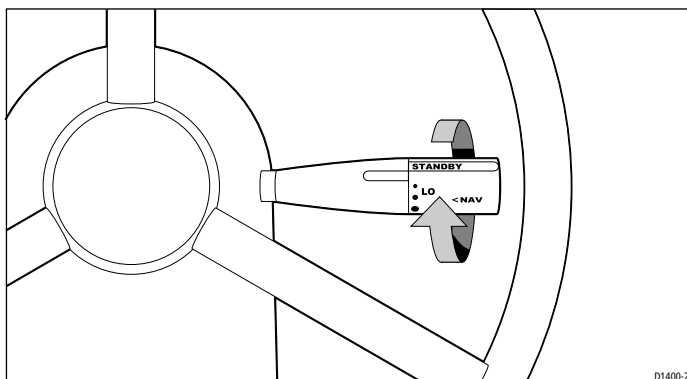

D1400-2

Disengaging the pilot

You can disengage the SportPilot at any time by turning the rotary control switch to **STANDBY**.

Making course changes

Large course changes

When your boat is under autopilot control, you can override the pilot at any time by steering the wheel in the normal way.

As soon as you release the wheel, the SportPilot automatically regains control to maintain the boat's current heading.

CAUTION:

You MUST center the helm after making large course changes. If you do not center the helm, the autopilot could become unstable or take a long time to settle onto the required heading.

Minor course changes

When your boat is under autopilot control, you can make minor course adjustments in 1° increments by pressing the:

- -1° (Port) or
- +1° (Starboard) switches on top of the control stalk

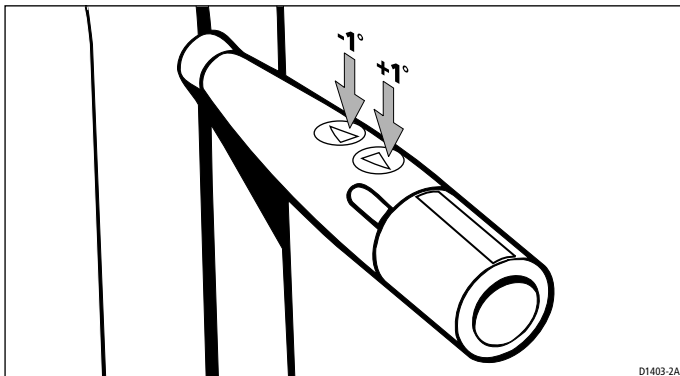

D1403-2A

Note: You can also make course changes using an optional handheld remote control or repeater autopilot control unit (if fitted).

Adjusting autopilot gain

The autopilot gain setting determines the amount of rudder the pilot applies during course change. Autopilot gain is relative to the speed of your boat. There are five available gain settings on the SportPilot:

- **LO**: lowest gain setting
- three mid-range positions
- **HI**: highest gain setting

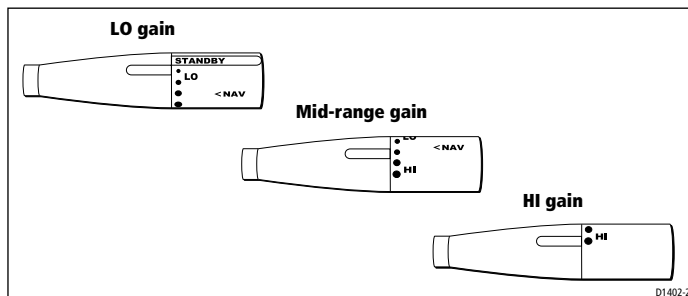

Setting the gain for your boat

WARNING:

It is vital that the autopilot gain control is set correctly – an incorrect setting will lead to poor steering performance and can produce violent course changes at high speed.

The ideal gain setting for one boat may not be ideal for another, so finding the correct setting for your boat will be down to experimentation and experience. The following **HI** and **LO** setting details are general guidelines only.

HI gains

Generally, low boat speeds require a medium to **HI** setting to provide better course keeping.

WARNING:

This setting is not recommended for high speeds as it may cause some instability and, therefore, could be dangerous.

LO gains

Most high speed boats will require a medium to **LO** setting. This provides the greatest stability.

Automatic gain correction

Autopilot gain is automatically adjusted if the SportPilot is connected to either a:

- SeaTalk instrument transmitting boat speed through the water or boat speed over the ground, or
- NMEA instrument transmitting NMEA 0183 boat speed through the water or boat speed over the ground

Initially set the control stalk to the gain position most suited to your boat. The SportPilot will then automatically adjust the gain (up or down) from this setting as your boat speed changes.

Note: *The SportPilot must receive boat speed information via SeaTalk or NMEA to automatically adjust the gain.*

2.3 Using Navigator (Track) mode

The SportPilot can automatically steer to a waypoint using information from any SeaTalk navigator or NMEA 0183 compatible GPS. Alternatively, the SportPilot can follow a route defined on a SeaTalk Navcenter or GPS.

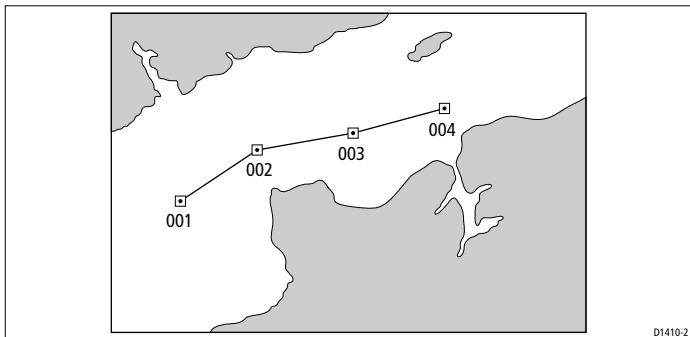

Entering Navigator (Track) mode

To enter Navigator mode so you follow a route of waypoints:

1. Create or select a route of waypoints on the navigator.
2. Engage the pilot and steer your boat onto the first waypoint bearing (within 0.3 nm of track).
3. Press in the end of the control stalk to enter Navigator (Track) mode. The yellow **NAV** light glows to confirm this selection.

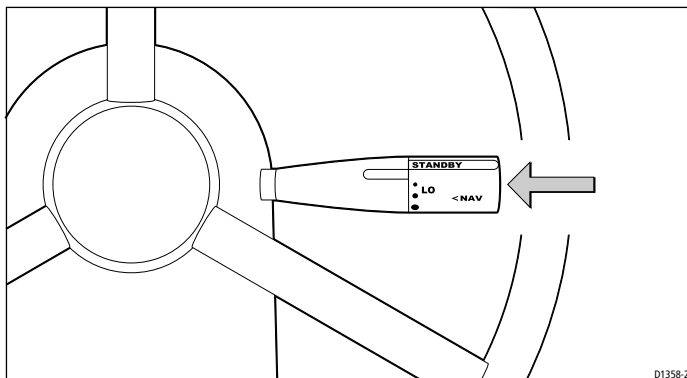

Exiting Navigator (Track) mode

To exit Navigator (Track) mode and return to Standby mode, turn the end of the control stick back to **STANDBY**. The yellow **NAV** light will go out and the red **AUTO** light will flash.

Turning to next waypoint

In Navigator (Track) mode, the SportPilot automatically determines the direction to the target waypoint:

- if a turn to port is required, the SportPilot emits 2 short beeps
- if a starboard turn is needed, the SportPilot emits 1 short beep

To accept the turn, press in the end of the control stalk (**NAV**).

CAUTION:

Before you accept a turn to port or starboard, ALWAYS make sure that it is safe to do so.

Arriving at a waypoint

When you arrive at a target waypoint, the SportPilot requests permission to advance to the next waypoint:

- two short beeps for a port turn
- one short beep for a starboard turn

Make sure that it is safe to make the turn, then press **NAV** to advance to the next waypoint.

Safety points

The SportPilot can only follow a user defined route if the navigation equipment transmits all of the following information:

- bearing to waypoint (BTW)
- cross track error (XTE)
- waypoint number

If cross track error (XTE) is the only available information, the SportPilot will advance to the next waypoint without requesting permission. In this case, you should always manually steer the boat to within 15° of the new bearing to waypoint before you press **NAV**.

Audible alarms in Navigator mode

The SportPilot emits the following audible warning alarms in Navigator (Track) mode:

Audible alarm	Reason
2 short beeps	Turn to port required
1 short beep	Turn to starboard required
2 short and 1 long beep	Off course
Continuous short beeps	Track problem (large XTE, no data or data error)

Chapter 3: Maintenance & Fault Finding

This chapter provides information about maintaining your SportPilot system, obtaining product support and solving common problems.

3.1 General maintenance

CAUTION:

The SportPilot and fluxgate compass do not contain any user serviceable parts. These products should be serviced only by authorized Raymarine service technicians.

Routine cabling checks

- Make sure all connections are firmly attached.
- Examine the cables for signs of wear or damage – replace any damaged cables.

Cleaning the SportPilot

- If the SportPilot is dirty, wipe it with a clean, damp cloth.
- **Never** use chemical or abrasive materials to clean the SportPilot.

EMC advice

- When powered up, all electrical equipment produces electromagnetic fields. These can cause adjacent pieces of electrical equipment to interact with one another, with a consequent adverse effect on operation.
- To minimize these effects and enable you to get the best possible performance from your Raymarine equipment, guidelines are given in the installation instructions, to enable you to ensure minimum interaction between different items of equipment, i.e. ensure optimum Electromagnetic Compatibility (EMC).
- Always report any EMC-related problems to your nearest Raymarine dealer. We use such information to improve our quality standards.
- In some installations, it may not be possible to prevent the equipment from being affected by external influences. In general this will not damage the equipment but it can lead to spurious resetting action, or momentarily may result in faulty operation.

3.2 Fault finding

All Raymarine products are designed to provide many years of trouble-free operation. We also put them through comprehensive testing and quality assurance procedures before shipping.

In the unlikely event that a fault does occur with your autopilot, use the following table to help identify the problem and provide a solution. If you cannot resolve the problem yourself, refer to the product support information below.

SYMPTOM	CAUSE	SOLUTION
SportPilot does not power up.	Power connection at the power supply or SportPilot.	Make sure that all connections are secure.
	Blown fuse or circuit breaker.	Replace fuse or circuit breaker.
Over-active heading correction.	Autopilot gain too high.	Turn control stalk towards LO gain.
Poor course keeping.	Autopilot gain too low.	Turn control stalk towards HI gain.
Over-active heading correction or poor course keeping after adjusting the gain.	Pre-programmed settings not suitable for your boat.	Contact your nearest Raymarine dealer.
	If a rudder position sensor is connected: the SportPilot may not have sensed its presence.	Auto-sensing can take up to 10 minutes. During this time you may experience poor course-keeping.
NAV (Track) mode: SportPilot steers onto wrong bearing after you accept the turn alarm.	Compass heading alignment incorrect.	Complete the heading alignment procedure (see page 52)

3.3 Product support

Raymarine products are supported by a worldwide network of distributors and Authorized Service Representatives. If you encounter any difficulties with this product, please contact either your national distributor, service representative, or the **Raymarine Technical Services Call Center**. Refer to the back cover or the Worldwide Distributor List for contact details.

Part 2: Installing the SportPilot

Part 2: Installing the SportPilot

Chapter 4: Installing the SportPilot

Introduction

The SportPilot fits neatly over your boat's existing steering shaft with the steering wheel bolted directly onto the pilot. The unit can accommodate either $\frac{3}{4}$ in (19 mm) or 1 in (25 mm) steering shaft tapers using a simple adaptor collar (supplied).

All installations require an external fluxgate compass (supplied) to feed the SportPilot with precise heading information. This unit plugs directly into the rear of the pilot. It should be mounted in a central location to minimize the effects of pitching and rolling.

If your boat has a hydraulic helm pump, you **must** also fit a rudder position sensor. You will need to use either a linear or rotary rudder sensor, depending on your boat's steering system (see *page 26*).

The sections in this chapter explain how to install and connect the components of your SportPilot system:

4.1	Planning the installation	page 20
4.2	Installing the compass	page 23
4.3	Installing the rudder position sensor – optional	page 26
4.4	Providing power for the SportPilot	page 37
4.5	Connecting SeaTalk equipment	page 39
4.6	Installing the SportPilot	page 41

4.1 Planning the installation

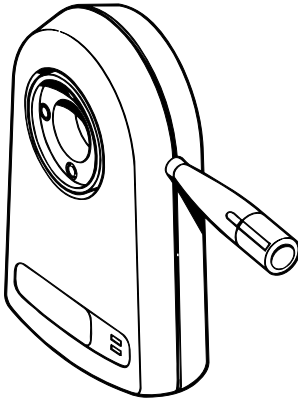

SportPilot/SportPilot Plus

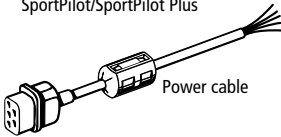

Power cable

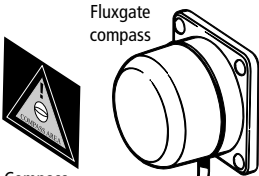

Fluxgate compass

Compass warning label

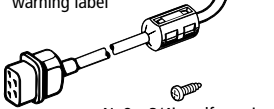

No8 x 3/4in self-tapping
pan-head screws (x4)

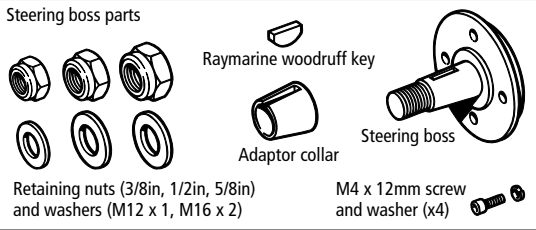

Retaining nuts (3/8in, 1/2in, 5/8in)
and washers (M12 x 1, M16 x 2)

M4 x 12mm screw
and washer (x4)

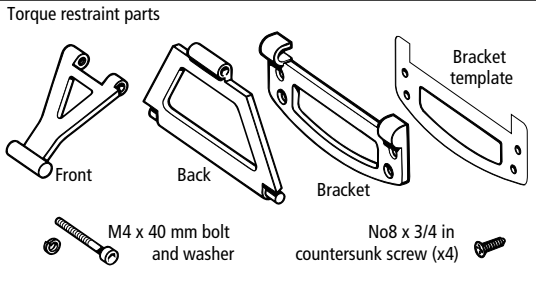

Front

Back

Bracket

Bracket
template

M4 x 40 mm bolt
and washer

No8 x 3/4 in
countersunk screw (x4)

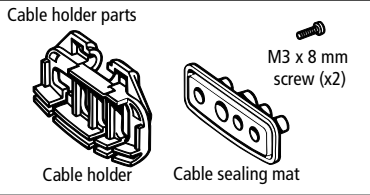

Cable holder parts

Cable holder

Cable sealing mat

M3 x 8 mm
screw (x2)

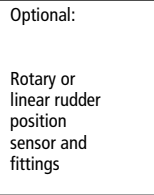

Optional:

Rotary or
linear rudder
position
sensor and
fittings

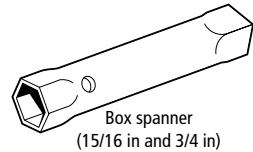

Box spanner
(15/16 in and 3/4 in)

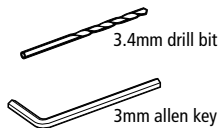

3.4mm drill bit

3mm allen key

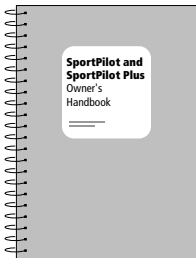

Owner's Handbook

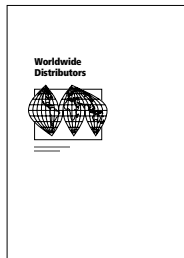

Worldwide Distributor List

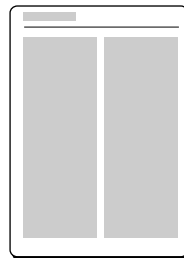

Quick Reference Card

Installation instructions

Before you start installing your SportPilot system, use the illustration to check the parts supplied. Then read through the following information and the relevant installation sections in this chapter.

Cabling guidelines

- consider how you will run cables to and from each component
- avoid running cables through bilges where possible
- avoid running cables close to fluorescent lights, engines, radio transmitting equipment etc.

EMC suppression ferrites

We supply the fluxgate compass and power cables with suppression ferrites fitted. Always use these ferrites supplied by Raymarine.

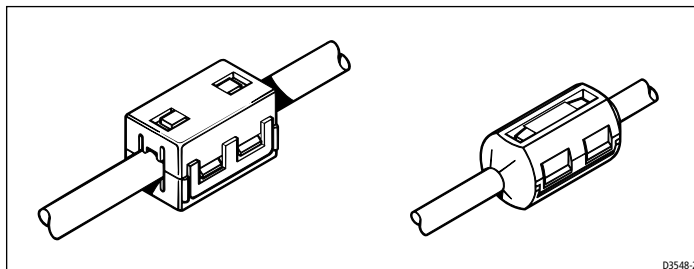

During installation you should position these ferrites as close as possible to the SportPilot, just behind the bulkhead. You may need to remove the ferrites during installation. If you do so, you **MUST** reassemble them around the cable when installation is complete.

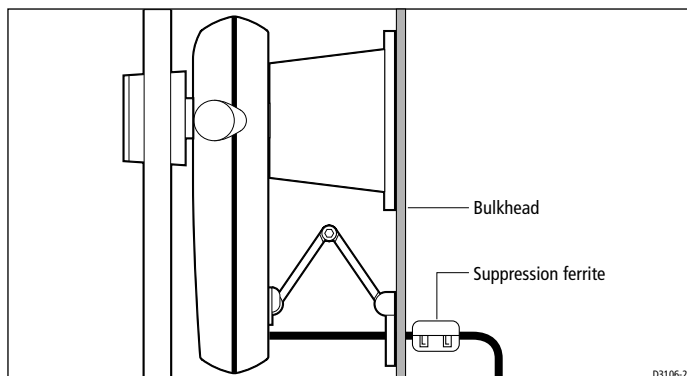

EMC installation guidelines

All Raymarine equipment and accessories are designed to the best industry standards for use in the recreational marine environment. Their design and manufacture conforms to the appropriate Electromagnetic Compatibility (EMC) standards, but correct installation is required to ensure that performance is not compromised.

Although every effort has been taken to ensure that they will perform under all conditions, it is important to understand what factors could affect the operation of the product.

The guidelines given here describe the conditions for optimum EMC performance, but it is recognized that it may not be possible to meet all of these conditions in all situations. To ensure the best possible conditions for EMC performance within the constraints imposed by any location, always ensure the maximum separation possible between different items of electrical equipment.

For **optimum** EMC performance, we recommend that:

- Raymarine equipment and cables connected to it are:
 - At least 3 ft (1 m) from any equipment transmitting or cables carrying radio signals e.g. VHF radios, cables and antennas. In the case of SSB radios, increase the distance to 7 ft (2 m).
 - More than 7 ft (2 m) from the path of a radar beam. A radar beam can normally be assumed to spread 20 degrees above and below the radiating element.
- The equipment is supplied from a separate battery from that used for engine start. Voltage drops below 10 V, and starter motor transients, can cause the equipment to reset. This will not damage the equipment, but may cause the loss of some information and may change the operating mode.
- Raymarine specified cables are used. Cutting and rejoining these cables can compromise EMC performance and must be avoided unless doing so is detailed in the installation manual.
- If a suppression ferrite is attached to a cable, this ferrite should not be removed. If the ferrite needs to be removed during installation it must be reassembled in the same position.

Connections to other equipment

If your Raymarine equipment is to be connected to other equipment using a cable not supplied by Raymarine, a suppression ferrite **MUST** always be attached to the cable near to the Raymarine unit.

4.2 Installing the compass

The compass contains a self-levelling mechanism. This enables the compass to provide accurate readings with pitch and roll movements up to +/- 35°.

Note: *The rattle that the fluxgate compass makes when shaken is normal. It is caused by the pendulum weight hitting the inside of the case.*

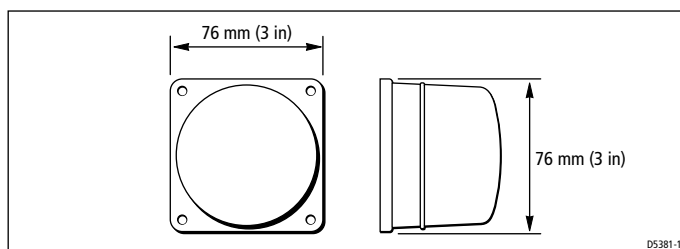

Fluxgate compass dimensions

Compass location

To achieve the best performance from the compass, mount it:

- With the Raymarine logo facing the bow.
Note: If it is not possible to install the fluxgate compass with the logo facing the bow, you must complete the Compass Calibration procedures (see Chapter 5: Compass Calibration).
- As close as possible to the boat's pitch and roll center.
- At least 0.8m (2ft 6in) away from your boat's steering compass to avoid deviation of both compasses.
- As far away as possible from large iron masses, such as the engine or other magnetic devices.

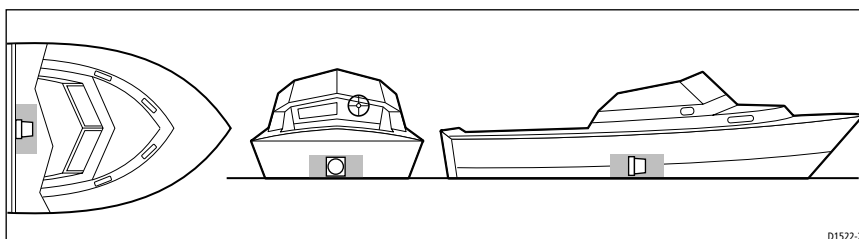

Note: To check if the intended mounting location is free from magnetic influence, tape a handheld compass to the chosen location, then turn the boat through 360°. The readings on the handheld compass and your boat's main steering compass (if accurately aligned) should not differ by more than 10° at any heading.

Compass mounting

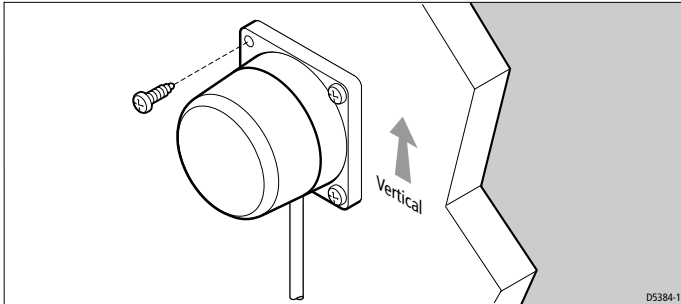

CAUTION:

You must mount the fluxgate compass on a vertical bulkhead, with the cable exiting at the base.

1. Hold the compass against the mounting location.
2. Mark the four mounting holes, then remove the compass.
3. Drill four pilot holes using a 3 mm ($\frac{1}{8}$ in) drill bit.
4. Making sure the cable exits at the bottom of the compass, secure the fluxgate compass using the self-tapping screws provided (No 8 x $\frac{3}{4}$ in, pan-head).

Note: Stick the supplied warning label near to the compass, where it is clearly visible.

Compass cabling

1. Route the cable to the steering station, taking into account the EMC installation guidelines (page 22).
2. Secure the cable at regular intervals with suitable cable clips/ties.

Note: You will plug the moulded connector into the **COMPASS** socket when installing the SportPilot (see page 45). You will also need to attach the supplied suppression ferrite behind the bulkhead as close as possible to the SportPilot.

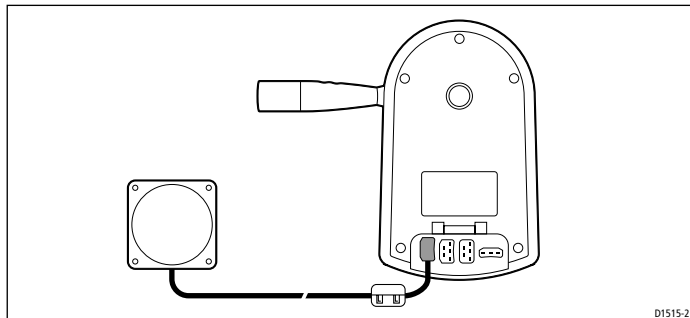

Cutting and joining the compass cable

You should not cut and rejoin the fluxgate compass cable unless absolutely necessary. If you do have to cut the cable, use Scotchlock connectors to re-join the wires color for color.

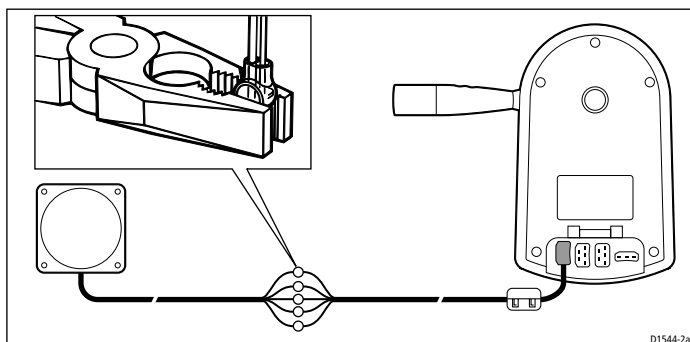

Note: Scotchlock connectors are not supplied with the Fluxgate Compass. These must be purchased from your local dealer.

4.3 Installing the rudder position sensor – optional

A rudder position sensor will improve your SportPilot's performance by providing precise information about the rudder's position.

CAUTION:

If your boat has a hydraulic helm pump, you MUST fit a rudder position sensor for the SportPilot to function accurately.

Depending on your boat's steering system, you will need to use either a linear or rotary rudder sensor. Generally, you will need:

- a linear rudder sensor if your boat has an outboard engine steered by a 'bullhorn' style hydraulic ram
- a rotary rudder sensor if your boat has an inboard ram.

Linear rudder position sensor – installation (hydraulic outboard steering systems)

Note: *Hydraulic outboard steering systems MUST be fitted with a linear rudder position sensor.*

The linear rudder position sensor (part number: Z229) is designed for 'bullhorn' style hydraulic outboard steering systems. It is totally weatherproof and designed to be mounted on the bullhorn ram.

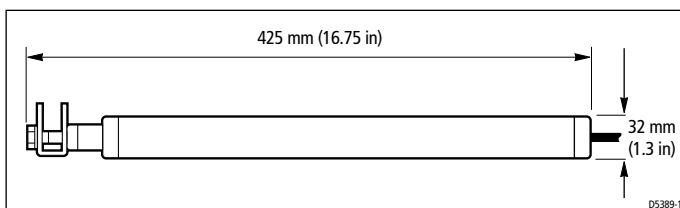

Linear rudder position sensor – dimensions

Positioning the linear rudder position sensor

You **MUST** ensure that:

- there is equal travel of the sensor shaft to port and starboard (as shown by **A** on the diagram)
- the sensor shaft is parallel to the ram – if the shaft is not parallel, the U-bracket could be driven off the ram when the shaft extends
- the sensor is clear of any obstructions when the engine(s) are turned hard-over or tilted up

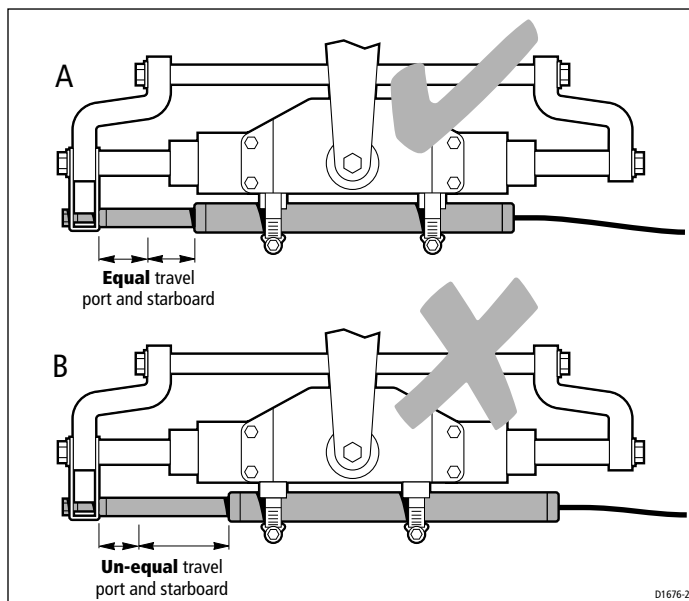

Mounting the linear rudder position sensor

1. Use the steering system to position the bullhorn ram amidships.
2. If necessary, release the hydraulic pressure from the boat's hydraulic steering system

Note: Contact your steering gear manufacture for advice on this step, and follow their instructions for releasing the hydraulic pressure.

3. Loosen the starboard bolt that secures the bullhorn ram's shaft to the end bracket.
4. Fit the U-bracket (supplied) over the end bracket and the bullhorn ram's shaft.
5. Hand tighten the starboard bolt to hold the U-bracket in place.
6. Fully open the hose clamps (supplied) using a flat bladed screwdriver, then hang them over the bullhorn ram.
7. Place the spacers (supplied) on the bullhorn ram and use adhesive tape to secure them temporarily.
8. Pull out the rudder sensor's shaft until its alignment mark is level with the end of the barrel.
9. Position the rudder sensor against the spacers so the threaded rod end of its shaft passes through the U-bracket.

10. Tighten the hose clamps around the bullhorn ram and the rudder sensor's barrel.
11. Tighten the starboard bullhorn bolt to secure the U-bracket.
12. Fit and tighten the supplied nut and washer to secure the threaded rod end of the sensor's shaft to the U-bracket.

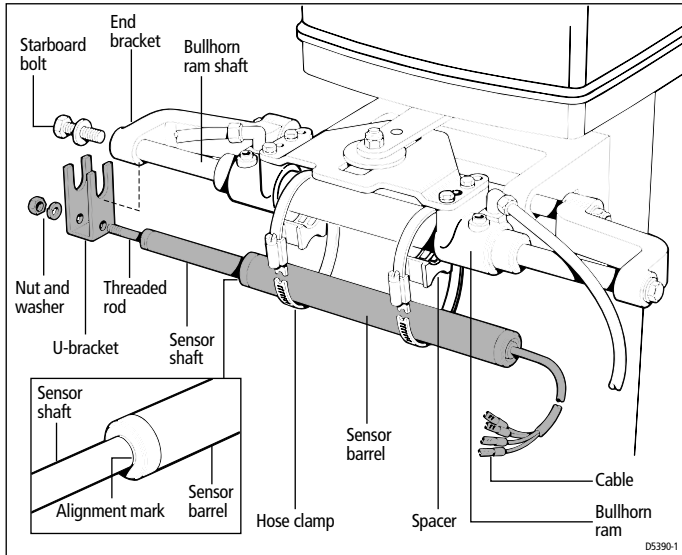

- Notes:** 1. If there is restricted space below the ram, you can mount the sensor in front of the ram.
2. We recommend installing the sensor with its shaft pointing to starboard. If you cannot install the unit in this orientation, you can fit it with the shaft pointing to port. If you do this, the SportPilot will automatically correct itself, so no manual adjustment is necessary.

Linear rudder position sensor – cabling

1. Connect the linear rudder position sensor cable to the **RUDDER REF** cable (color for color). Use the Scotchlock connectors and crimp the connectors with a pair of pliers.

Note: Connect the cables close to the SportPilot so that the connectors remain dry and free from strain.
2. Route the cable to the SportPilot, taking into account the EMC installation guidelines (*page 21*).

Note: To allow for the bullhorn's movement, leave a loop of cable at the end of the linear rudder position sensor.

Note: You will plug the moulded connector into the **RUDDER REF** socket when installing the SportPilot (see page 45).

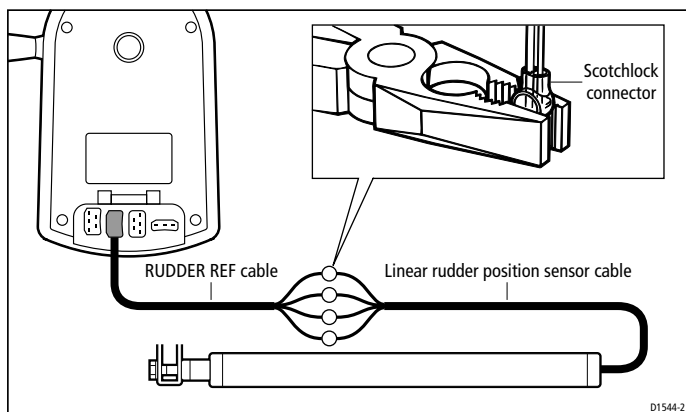

Post installation checks

When you have connected the sensor to your SportPilot, pressurize the steering system (if required).

Note: Contact your steering gear manufacture for advice on this step. Follow their instructions for re-pressurizing the hydraulic pressure.

Rotary rudder position sensor – installation (hydraulic inboard steering systems)

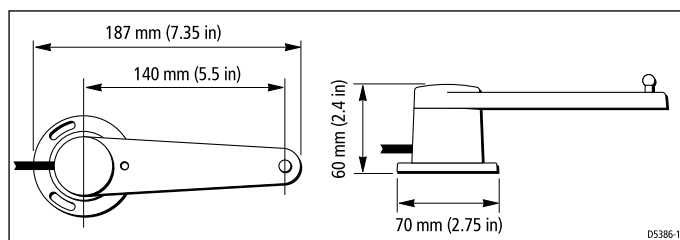

Note: Hydraulic inboard steering systems **MUST** be fitted with a linear rudder position sensor.

The rotary rudder position sensor can be used on hydraulic inboard steering systems to transmit the precise position of the boat's steering to the SportPilot. Depending on your engine installation, you can mount the sensor to the steering arm, or to the tie bar.

Connecting the sensor to a steering arm

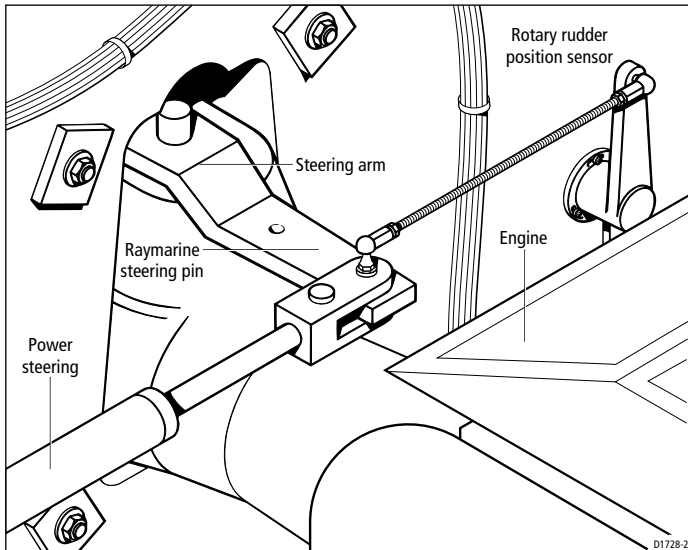

Typical installation – sensor connected to horizontal steering arm

Before you attempt to fit the sensor to a steering arm, please consider the following points:

- If the distance between the transom and the steering arm attachment point is greater than 65 mm (2.5 in), it may be necessary to mount the sensor on a fabricated base (e.g. a metal bracket or block of wood). This ensures that the connecting rod is at 90° to the center-line of the sensor and steering arms.
- It may be necessary to relocate other equipment installed on the transom.
- Although the illustration shows the sensor arm pointing upwards, if necessary the sensor can be installed so that the arm is pointing towards the bottom of the boat.
- Whichever way you install the transducer, the cable should always exit the sensor base directly opposite the sensor arm.

CAUTION:

Before you start installing the rotary rudder position sensor, make sure that you have a spare cotter/split pin available in case the original is lost or cannot be used again.

Mounting the sensor

1. With the steering amidships, align the sensor as shown in the relevant illustration below:

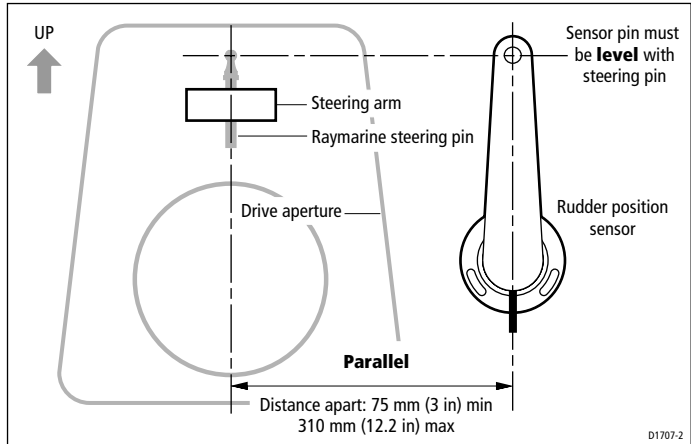

Single drive system with horizontal steering arm

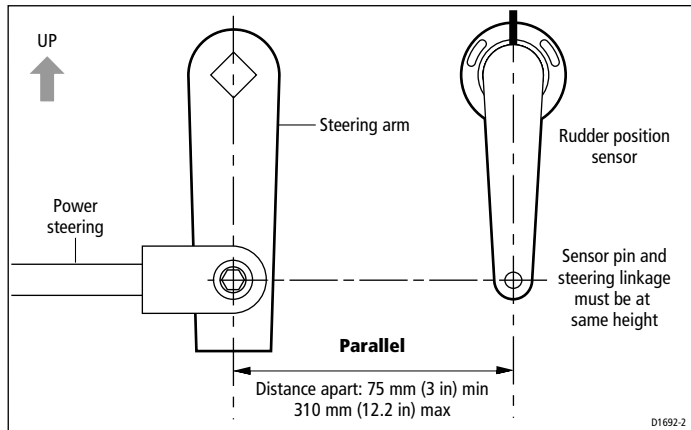

Single drive system with vertical steering arm

2. Use the three self-tapping screws to attach the sensor directly to the transom (or a fabricated mounting base).
3. Remove the pin securing the steering arm to the power steering.
4. Fit the Raymarine steering pin and retain with a split/cotter pin.

Note: *If your boat has a Volvo steering system, you should fit the plastic spacer to the steering pin (as shown in the following illustration) so the pin does not foul the steering system.*

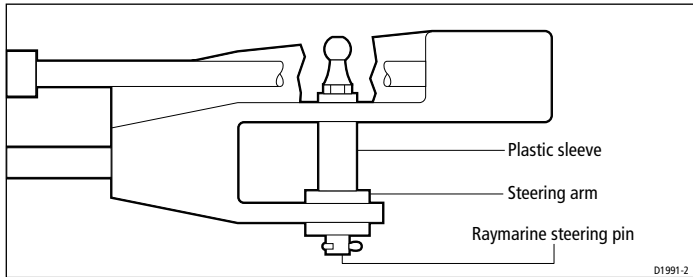

Typical Volvo installation

5. Cut the threaded connecting rod to length.
6. Screw the lock nuts and sockets onto the connecting rod.
7. Press the sockets onto the steering pins.
8. Turn the steering from side to side to make sure that the linkage is free from obstructions at all angles.

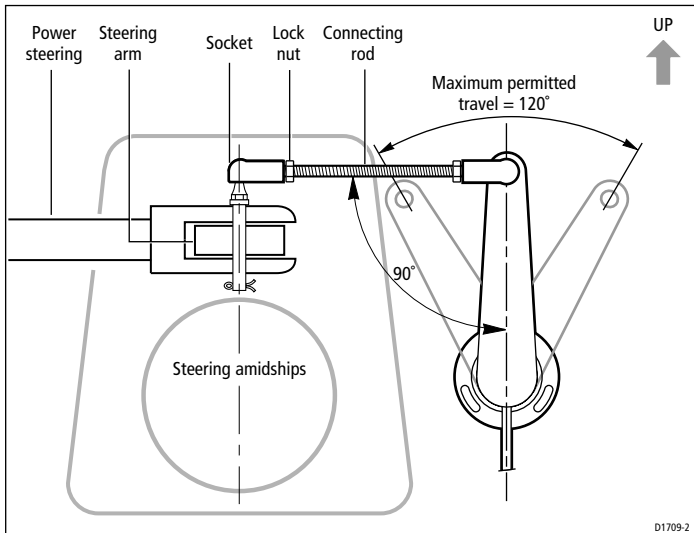

Single drive system with horizontal steering arm

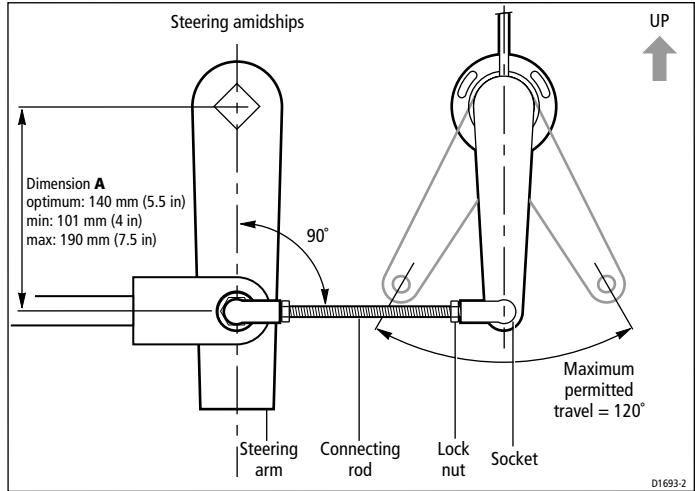

Single drive system with vertical steering arm

Note: Ideally, dimension A should be 140 mm (5.5 in). However, if necessary it can fall anywhere within the given minimum and maximum limits. This will not affect autopilot performance, but will slightly alter the scaling of the data sent to the SportPilot.

Preventing steering pin movement

Note: This section does not apply to Volvo steering systems.

If the Raymarine steering pin has excessive vertical free-play after replacing the original steering pin, use the plastic sleeve to reduce or remove any movement (as shown below).

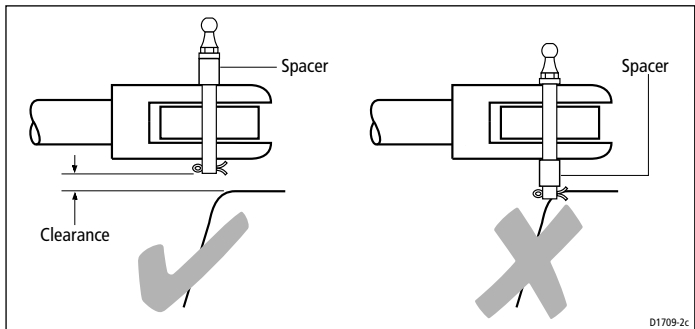

Note: The plastic spacer must be used to lift the pin so it does not foul on the steering system. If necessary, you can shorten the sleeve.

Connecting the sensor to a tie-bar

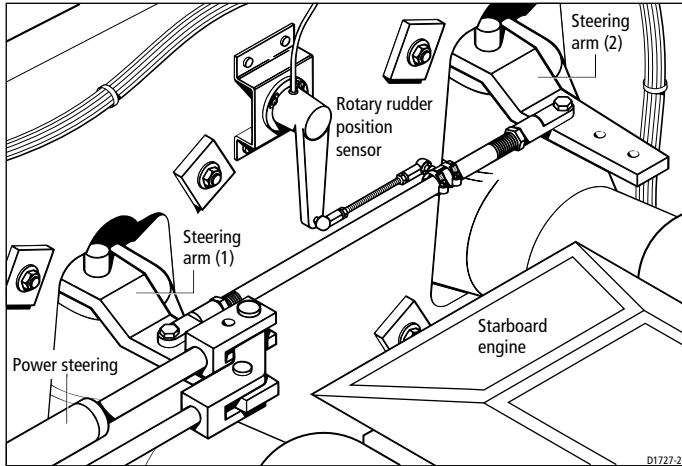

Before fitting the sensor to a tie-bar, consider these points:

- Not all installations will allow you to mount the rudder position sensor between the drive apertures. In this case, mount the sensor to a steering arm.
- You may need to mount the sensor on a fabricated base (as shown on the illustration) if the distance between the transom and the center of the tie bar is greater than 65 mm (2.5 in).

Mounting the sensor

1. Attach the sensor to the transom (or mounting base) at 90° to the tie-bar (as shown below).

Note: *Make sure the sensor steering pin is level with center of the tie-bar. If there are existing holes in the tie-bar, position the transducer within 75-310 mm (3.0-12.2 in) so you can use the threaded steering pin*

2. Position the steering amidships.
3. Measure 75 mm (3 in) to 310 mm (12.2 in) along the tie-bar from the center of the sensor steering pin.
4. Mark the tie-bar at this point.

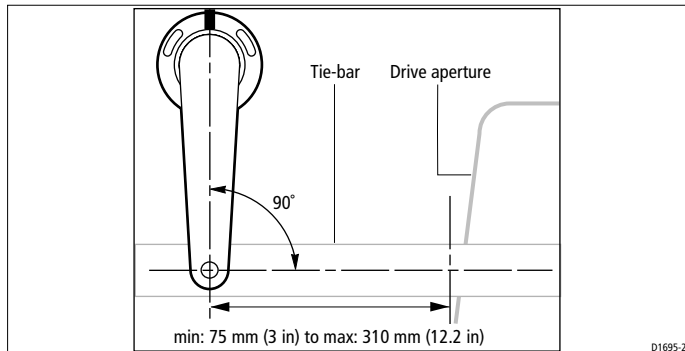

5. Use the two stainless steel hose clamps/jubilee clips to secure the steering pin to the tie-bar.

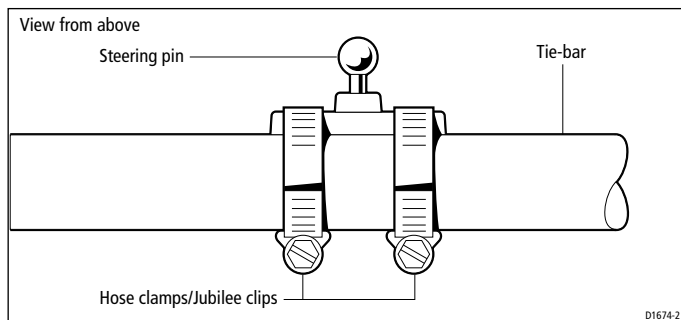

6. Cut the connecting rod to length.
7. Screw the lock-nuts and sockets onto the connecting rod.
8. Press the sockets onto the sensor pin and steering pin.

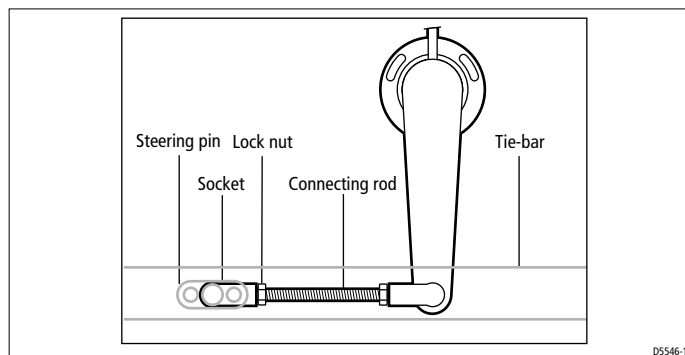

- Turn the steering from side to side. Make sure that the linkage is free from obstructions at all rudder angles.

Rotary rudder position sensor – cabling

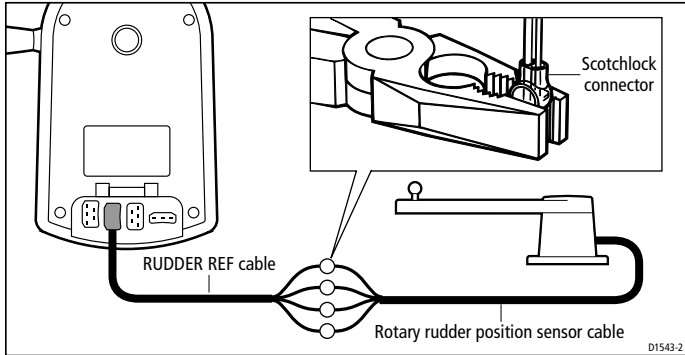

- Connect the linear rudder position sensor cable to the **RUDDER REF** cable (color for color). Use the Scotchlock connectors and crimp the connectors with a pair of pliers.
Note: Connect the cables close to the SportPilot so that the connectors remain dry and free from strain.
- Route the cable to the SportPilot, taking into account the EMC installation guidelines (*page 22*).

Note: You will plug the moulded connector into the **RUDDER REF** socket when installing the SportPilot (see *page 45*).

4.4 Providing power for the SportPilot

CAUTION:

To prevent the SportPilot draining the battery, always switch off the power supply when you leave your boat for long periods.

The SportPilot is supplied with a combined power/NMEA/SeaTalk cable consisting of 6 cores:

Brown:	12 V
Blue:	0 V
Red:	NMEA +ve
Black:	NMEA -ve
Yellow:	SeaTalk data +ve
Screen:	SeaTalk data -ve

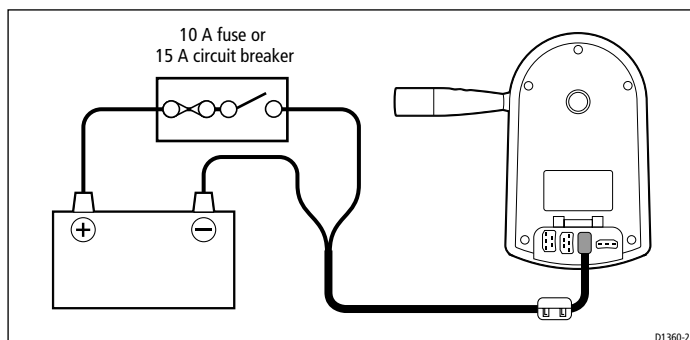

1. Connect the brown wire to the positive (12 V) terminal and the blue wire to the negative (0 V) terminal.
2. Protect the circuit with a 15 A fuse or 10 A thermal over-current circuit breaker (not supplied).
3. Route the cable to the SportPilot. You will plug the moulded end into the **POWER/NMEA** socket when installing the SportPilot.

Notes:

1. The red and black cores allow you to connect other manufacturer's equipment via NMEA (see page 38).
2. The yellow and screen cores can be used as an alternative way of connecting SeaTalk to the SportPilot (for example, if you have used a 3-pin deck connector). A positive (+) connection from the power source to the deck connector will be required.
3. Cut-back and insulate any unused cores.

Interfacing with NMEA equipment

Using the NMEA cores in the Power/NMEA cable, the SportPilot can interface directly with equipment capable of transmitting NMEA 0183 data format. Sentences decoded are:

Information	NMEA 0183 data
Cross Track Error	APA, APB, RMB, XTE, XTR
Bearing to Waypoint	APB, BPI, BWR, BWC, BER, BEC, RMB
Distance to Waypoint	WDR, WDC, BPI, BWR, BWC, BER, BEC, RMB
Waypoint Number	APB, APA, BPI, BWR, WDR, BWC, WDC, RMB, BOD, WCV, BER, BEC
Speed Through Water	VHW
Apparent Wind Angle and Speed	VWR
Water Depth	DBT

NMEA cabling

Connect the NMEA 0183 output connections from the NMEA equipment to the black and red NMEA cores of the power/NMEA lead as shown.

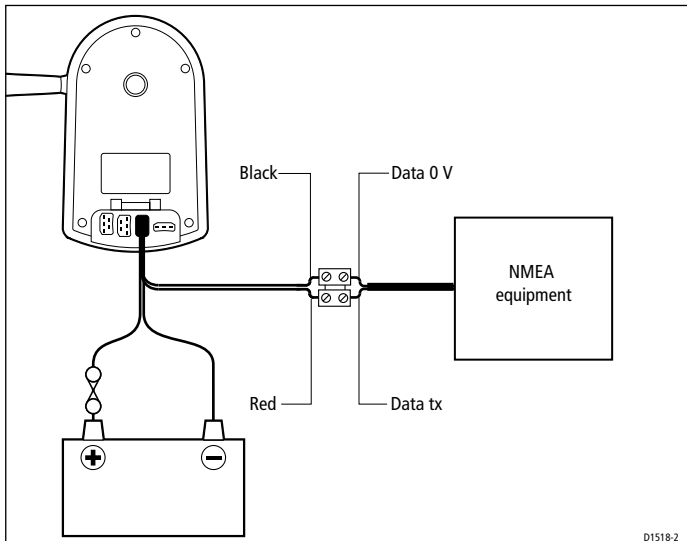

D1518-2

4.5 Connecting SeaTalk equipment

You can use the SportPilot's dedicated SeaTalk port to connect it to SeaTalk instruments or autopilot control units. The SportPilot can then share SeaTalk data with the instruments. It can also provide them with power if required.

Raymarine produce a range of SeaTalk cables you can use to connect the SportPilot to SeaTalk instruments:

- flat moulded plugs are used on recent SeaTalk instruments (e.g. ST30, ST40 and ST60)
- round plugs are used on older SeaTalk instruments (e.g. ST50)

Extension cables - flat moulded plugs at each end



Part no.	Type	Length
D284	Flat moulded plugs at each end	1 m (3 ft 3 in)
D285	Flat moulded plugs at each end	3 m (9 ft 10 in)
D286	Flat moulded plugs at each end	5 m (16 ft 5 in)
D287	Flat moulded plugs at each end	9 m (29 ft 6 in)
D288	Flat moulded plugs at each end	20 m (65 ft 6 in)

Conversion cables - flat moulded plug to round plug



Part no.	Type	Length
D187	Flat moulded plug to male round plug	0.15 m (6 in)
D188	Flat moulded plug to female round plug	0.3 m (12 in)

Extension cables - round plugs at each end



Part no.	Type	Length
D124	Male round plug to female round plug	1 m (3 ft 3 in)
D125	Male round plug to female round plug	3 m (9 ft 10 in)
D126	Male round plug to female round plug	6 m (19 ft 8 in)
D154	Male round plug to female round plug	9 m (29 ft 6 in)

Interface cables - flat moulded/round plug to bare ends

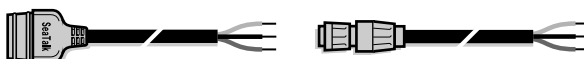

Part no.	Type	Length
D229	Flat moulded plug to bare ends	1 m (3 ft 3 in)
D179	Male round plug to bare ends	3 m (9 ft 10 in)
D181	Female round plug to bare ends	3 m (9 ft 10 in)

D5554-1

Typical SeaTalk connections

CAUTION:

Protect the power supply for the SeaTalk 12 V (red) line with a 5 A fuse (or equivalent circuit breaker) fitted as close to the SportPilot as possible.

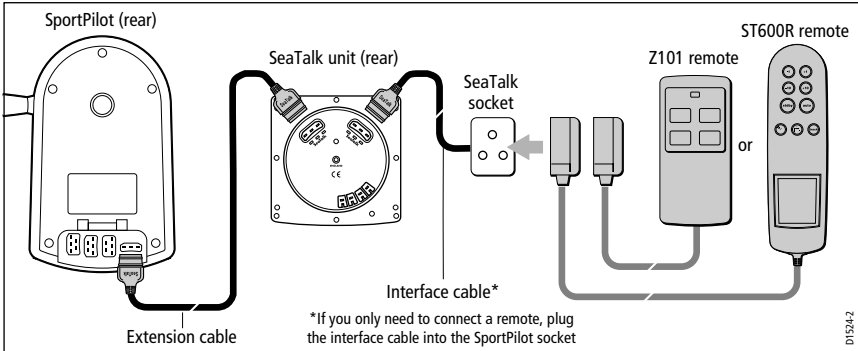

Connecting SportPilot to ST60 instrument and handheld remote

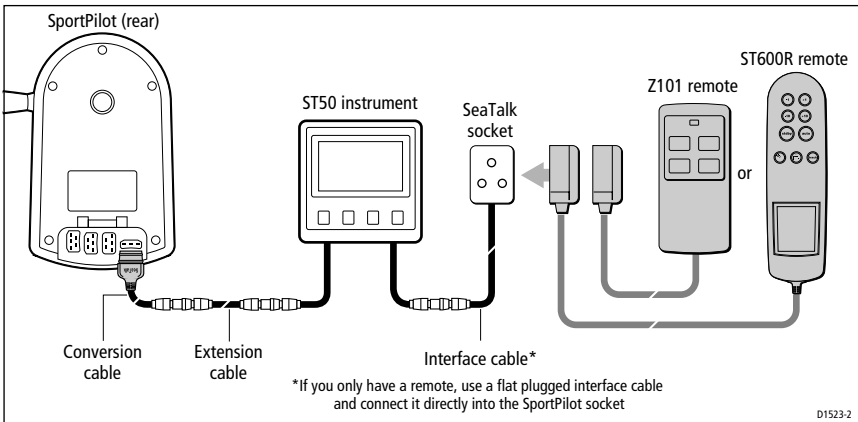

Connecting SportPilot to ST50 instrument and handheld remote

To connect just a remote to the SportPilot, either:

- use an interface cable (D229 – see *page 39*) and a 3-pin SeaTalk socket and plug (deck connector), or
- use a 3-pin deck connector and the yellow and green cores of the power cable: a positive (+) connection from the power source to the deck connector will be required

4.6 Installing the SportPilot

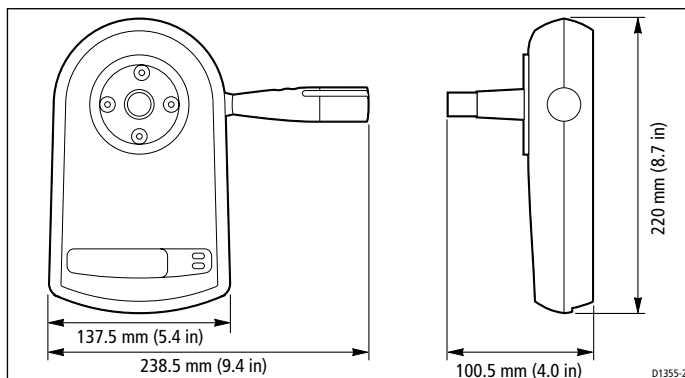

Step 1 – Remove the steering wheel

1. Turn the wheel all the way over to starboard lock. You MUST do this so you can tighten the retaining nut at the end of installation (see *page 48*) without damaging the SportPilot.
2. Remove the steering wheel hub.
3. Holding the steering wheel still, use a suitable socket or the supplied box spanner to remove the retaining nut and washer.
4. Carefully remove the steering wheel.
5. Remove the original woodruff key. **Retain the woodruff key as you will need to use it during a later stage of installation.**

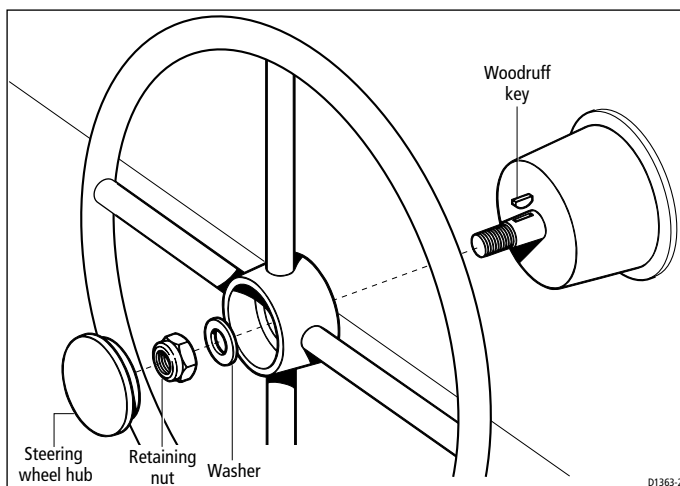

Step 2 – Mount the torque bracket

1. $\frac{3}{4}$ inch (19 mm) steering shafts only: assemble the supplied adaptor collar (5) to the shaft. Align the slot in the collar with the slot in the steering shaft.

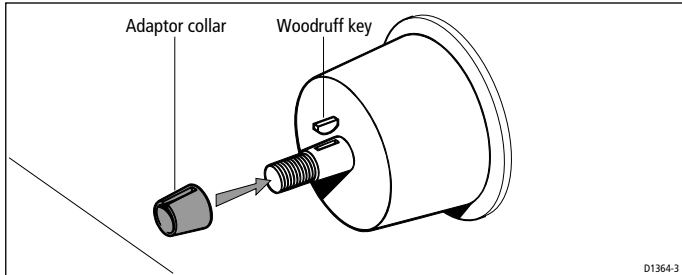

2. Temporarily assemble the front of the torque restraint to the back of the torque restraint.
3. Fit, *but do NOT tighten*, the washer and bolt to hold the front and back of the torque restraint together.

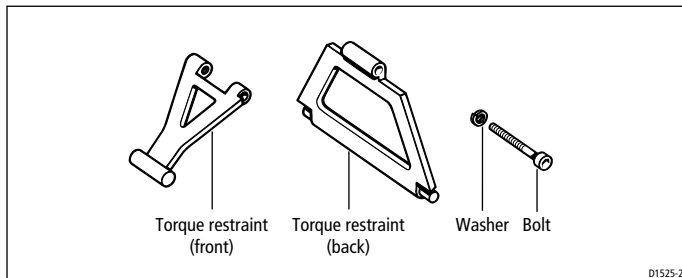

Note: *The torque restraint will not operate properly if the front and back are not assembled correctly. Therefore, once you have assembled the component parts, close the torque restraint as far as it will go. If you have assembled it correctly, the front will lay flat against the back.*

- Temporarily assemble the torque restraint to the cable holder.

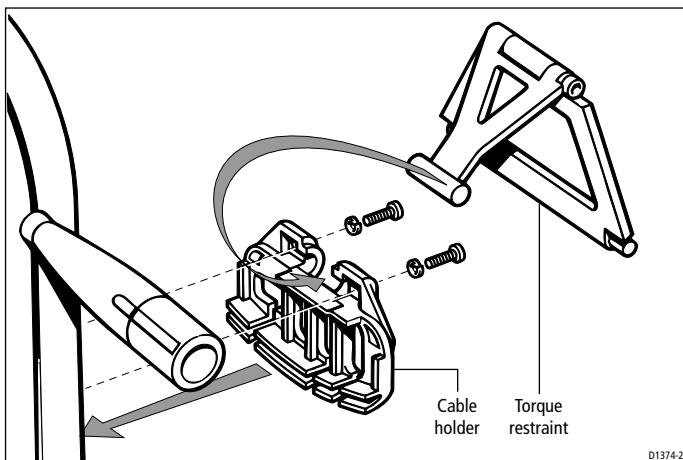

- Temporarily assemble the cable holder to the SportPilot using the screws and washers.
- Temporarily assemble the SportPilot to the steering shaft. **Do NOT tighten the retaining nut at this stage.**
- With the SportPilot aligned vertically and the control stalk pointing to starboard, unfold the torque restraint so it sits firmly against the bulkhead.
- Assemble the torque bracket to the torque restraint.

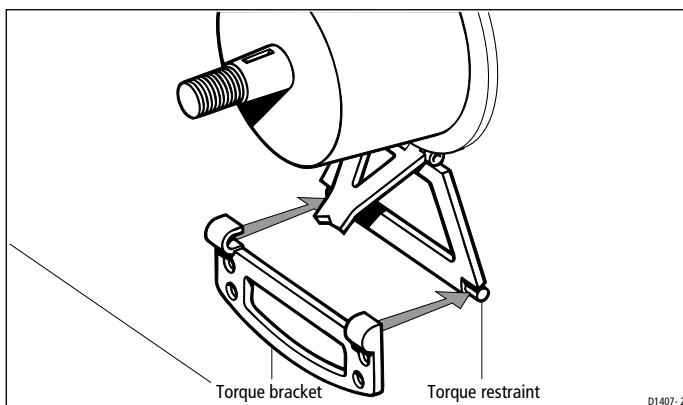

- Make sure that the lower edge of the torque bracket is level with the bottom of the SportPilot.

Note: *If your dashboard does not extend below the bottom of the SportPilot, you will need to manufacture an extension (from a suitable material) and permanently attach this to the dashboard to accommodate the torque bracket and torque restraint. The following illustration shows how to fit a dashboard extension correctly.*

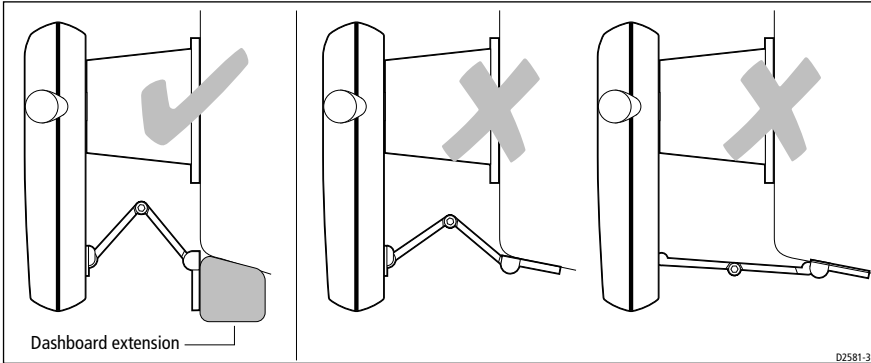

10. Draw around the torque bracket with a pencil.

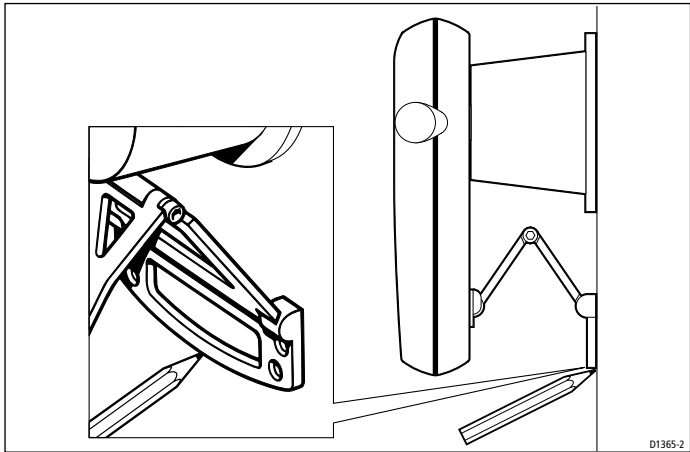

11. Remove the SportPilot (and adaptor collar/woodruff key on $\frac{3}{4}$ inch tapers) from the steering shaft.
12. **Remove the bolt from the torque restraint.**
13. Remove the cable holder from the back of the SportPilot.
14. Apply the self-adhesive template (supplied) to the bulkhead, using the pencil outline as a guide.

15. Drill 4 pilot holes using the drill bit (supplied) and then cut out the shaded cable aperture.

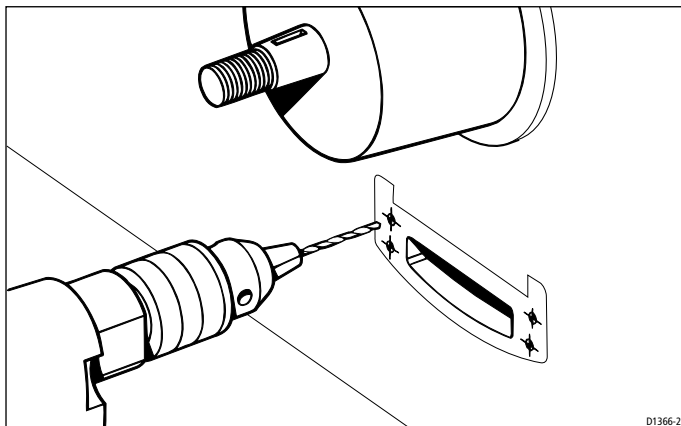

16. Remove the template and smooth any rough edges.

Step 3 – Plug the cables into the SportPilot

1. Pass the plugged ends of the power, compass, rudder position sensor (if fitted) and SeaTalk cables (if required) through the aperture.

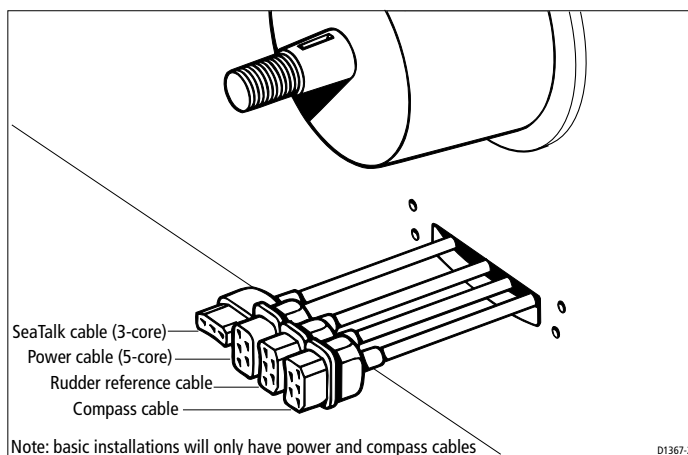

Note: Reposition the suppression ferrites so that they are located behind the bulkhead. In certain situations you need to remove the ferrites from the cable and re-fit them at the end of installation.

2. Cut the cable sealing mat must be cut (as shown) with a knife to allow the plugged cables to pass through it.

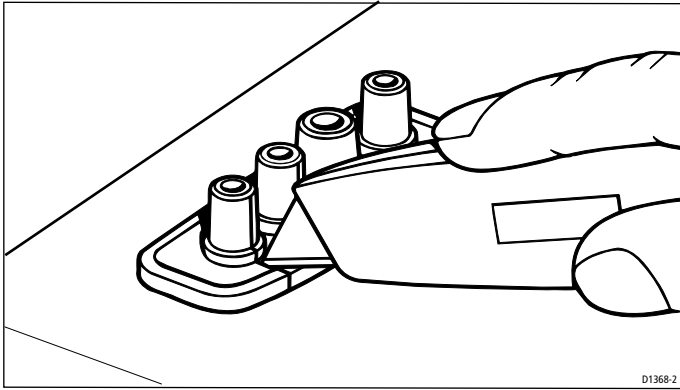

3. Pass the cables through the sealing mat.

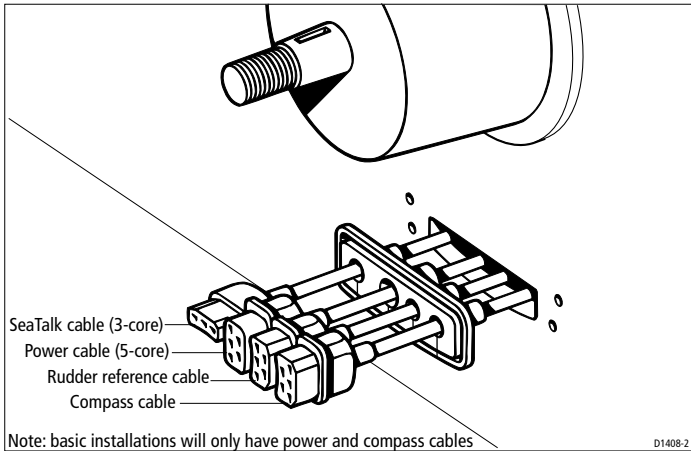

4. Pass the cables through the torque bracket aperture
5. Plug the cables into the SportPilot.

Note: *The cables are handed. Therefore, the power cable will only fit into the power socket and the compass cable will only fit into the compass socket.*

Step 4 – Assemble and secure the SportPilot

1. Assemble the free end of the torque restraint to the cable holder.
2. Fit the cable holder to the SportPilot using the washers and screws.

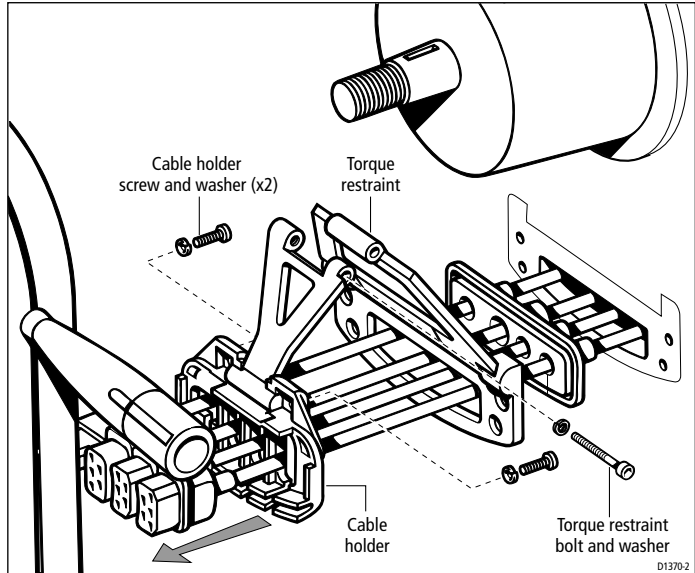

3. **$\frac{3}{4}$ inch (19 mm) taper:** Assemble the adaptor collar and the Raymarine woodruff key to the steering shaft.
1 inch (25 mm) taper: Fit the original woodruff key to the steering shaft.

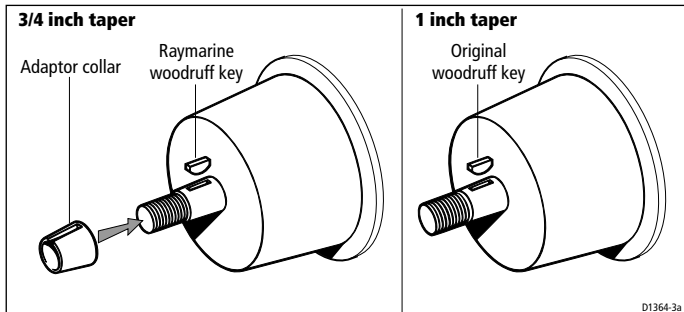

4. Secure the torque bracket and cable sealing mat to the bulkhead using the four self tapping screws.

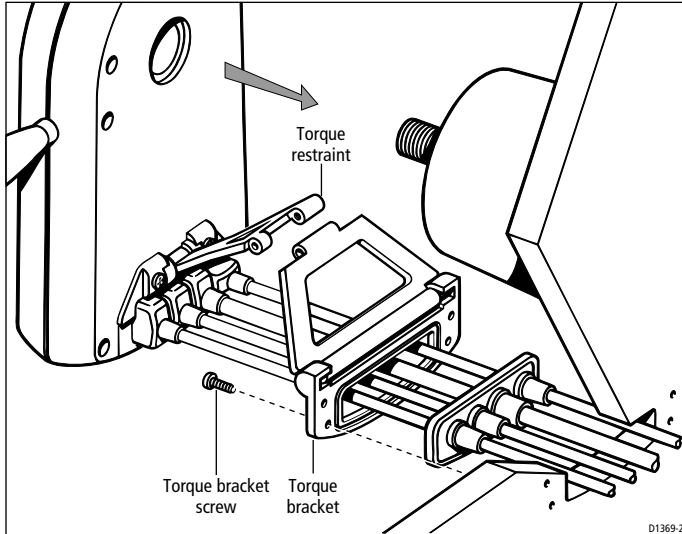

5. Assemble the SportPilot to the steering shaft.
6. Retain the SportPilot using the split washer and retaining nut.

CAUTION:

Do NOT attempt to support the SportPilot during tightening. Make sure the torque restraint bolt is removed so the SportPilot is free to rotate as you tighten the retaining nut. This will prevent damage to the SportPilot clutch.

7. Tighten the retaining nut to 25 lbft (34 Nm) maximum against the steering end stop.
8. Assemble the steering boss to the SportPilot.
9. Secure the steering boss using the 4 screws and washers.
10. **1 inch (25 mm) steering shafts only:**
 - assemble the adaptor collar to the steering boss
 - once assembled, fit the Raymarine woodruff key
11. Assemble the steering wheel to the SportPilot.
12. Secure the wheel using the nut and the washer. **Make sure that the woodruff key is fitted before tightening the wheel.**

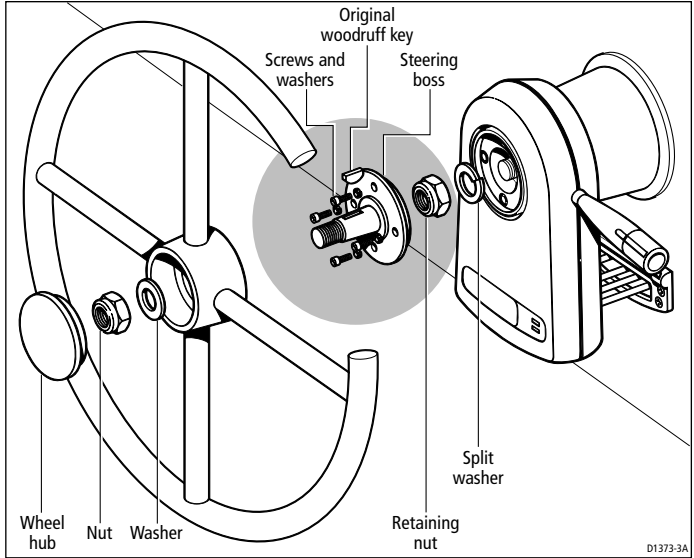

Fitting the SportPilot to 3/4 inch steering shaft

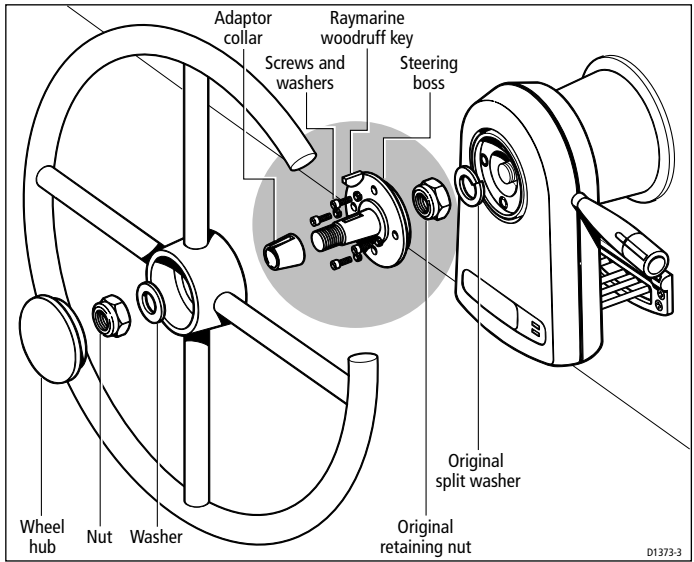

Fitting the SportPilot to 1 inch steering shaft

- Fit the torque restraint bolt and tighten it with the 3 mm allen key (supplied).

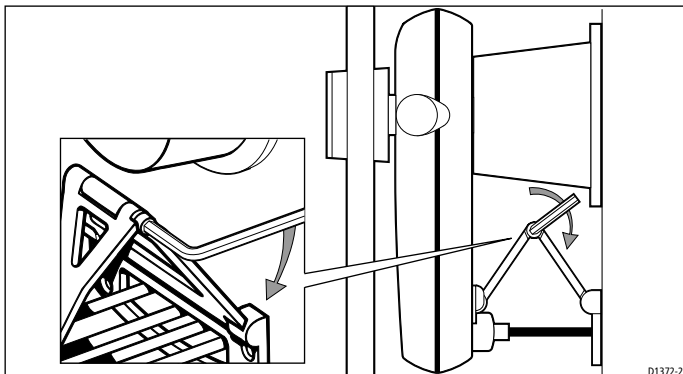

- Reposition/reassemble the suppression ferrites close to the bulkhead.

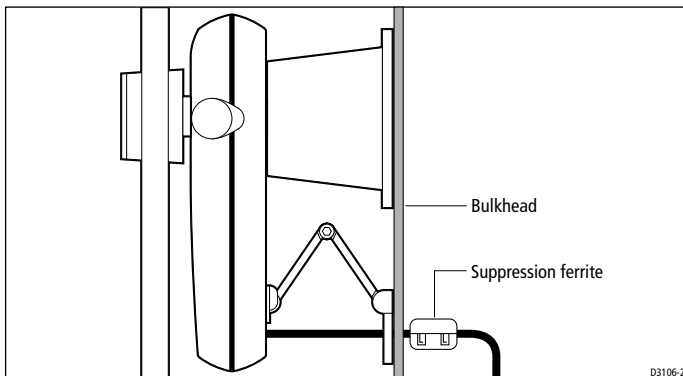

CAUTION: EMC conformance

Always check the installation before going to sea to make sure that it is not affected by radio transmissions, engine starting, etc.

Chapter 5: Compass Calibration

Important note

The procedures in this chapter only apply if:

- you have not been able to install the fluxgate compass on a forward facing bulkhead
or
- the SportPilot takes up an incorrect waypoint heading when operating in Navigator (Track) mode

Introduction

The SportPilot requires a heading reference to compensate for Northerly turning errors. In Navigator (Track) mode it also needs a heading reference to turn the boat towards the next target waypoint.

The SportPilot can usually obtain accurate heading information by attaching the fluxgate compass to a forward facing bulkhead (as described in *Chapter 4: Installing the SportPilot*).

However, if you are unable to mount the compass in this way or if the SportPilot steers onto the wrong heading, you must carry out compass linearization and heading alignment procedures in this chapter. These procedures ensure that the reading from the fluxgate compass corresponds to the heading displayed by your boat's compass.

5.1 Compass linearization and heading alignment

This procedure reduces any fluxgate compass errors caused by ferrous objects.

1. Motor the boat to a location clear of any other traffic. Sea conditions should be calm with minimal tidal flow.
2. Select Standby mode, and then press in and hold the end of the control stalk (**NAV**) for 10 seconds. The red **AUTO** and yellow **NAV** lights will then flash alternately and the unit will beep every second.

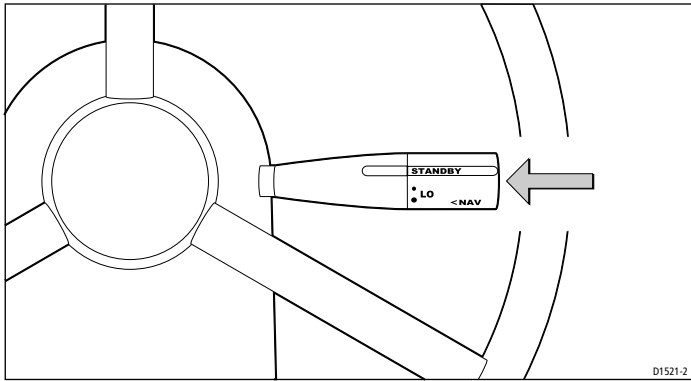

3. Turn the boat in a slow circles:
 - the boat speed should not exceed 3 knots
 - you should take at least 2 minutes to complete 360°

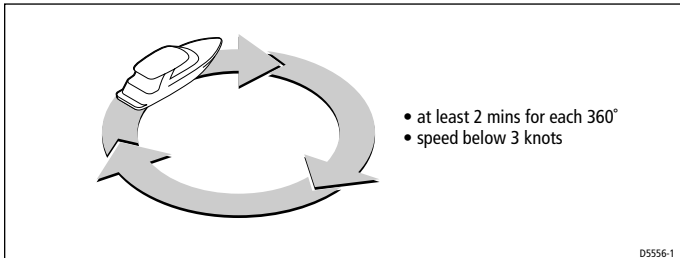

4. Keep turning your boat in circles until the SportPilot indicates that compass linearization is complete by:
 - flashing the red **AUTO** and yellow **NAV** lights together, and
 - emitting a 5 second beep

5. The SportPilot beeps again after the 5 second beep to let you know how much deviation has been detected. Each beep represents 5° of deviation:
 - 1 beep indicates 0° to 5° of deviation
 - 2 beeps indicate 5° to 10° of deviation
 - 3 beeps indicate 10° to 15° of deviation
 - 4 or more beeps indicate more than 15° of deviation

CAUTION:

The maximum acceptable deviation is 15° , so the fluxgate compass location is unsuitable if the SportPilot beeps more than 3 times. Re-site the fluxgate compass where there is less magnetic deviation and then repeat the linearization procedure.

6. Steer your boat so that it is pointing to magnetic North, (determined using a compass, GPS or a land reference).
7. Momentarily press either the **-1** or **+1** degree course change key (located on the top of the control stalk).

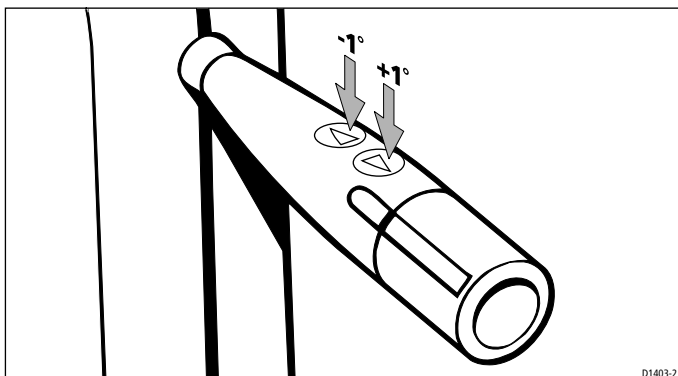
**To exit and save changes**

To save any changes and exit compass deviation/heading alignment, momentarily press in the end of the control stalk (**NAV**).

To exit without saving changes

If you wish to exit without saving any changes, turn the control stalk to the first autopilot gain position (**LO**) and then back to **STANDBY**.

5.2 Heading alignment without linearizing

If required, you can align the heading to magnetic North without carrying out compass linearization:

1. With the SportPilot in Standby mode, press and hold the end of the control stalk (**NAV**) for 10 seconds – the red **AUTO** and yellow **NAV** lights will begin to flash alternately.
2. Steer your boat so that it is pointing to magnetic North, (determined using a compass, GPS or a land reference).
3. Momentarily press either the **-1** or **+1** degree course change keys (located on the top of the control stalk).

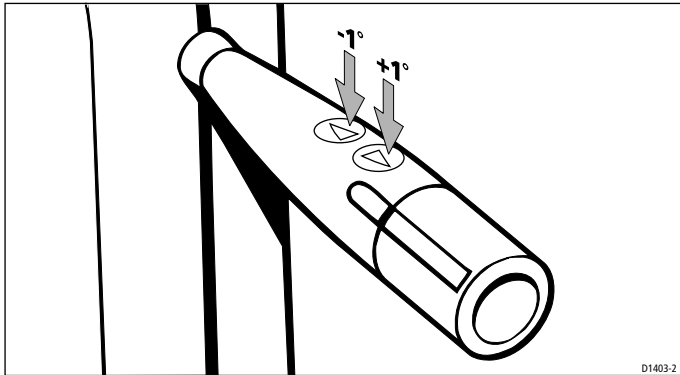

To exit and save changes

To save any changes and exit heading alignment, momentarily press in the end of the control stalk (**NAV**).

To exit without saving changes

If you wish to exit without saving any changes, turn the control stalk to the first pilot position (**LO**) and then back to **STANDBY**.

Index

A

Arriving at waypoints 13

Auto mode

Adjusting gain 11

Course changes 10

Entering Auto mode 9

Exiting Auto mode 10

C

Cabling

Compass 24

Guidelines 21

Linear rudder position sensor 28

NMEA 38

Power 37

Rotary rudder position sensor 36

Routine checks 15

SeaTalk 39

Cleaning the SportPilot 15

Compass calibration 51–54

Alignment (no linearizing) 54

Linearization and alignment 52

Compass installation 23–25

Cabling 24

Location 23

Mounting 24

Course changes 10

D

Disengaging the pilot - Standby mode 10

E

EMC

Installation guidelines 22

Servicing and safety guidelines 15

Engaging the pilot

Auto mode 9

Navigator (Track) mode 12

F

Fault finding 16

G

Gain 11

I

Installation 19

Compass 23–25

EMC guidelines 22

NMEA cabling 38

Parts supplied 20

Power cabling 37

Rudder position sensor 26–36

SeaTalk cabling 39

SportPilot 40–50

Suppression ferrites 21

L

Linear rudder position sensor

Installation 26–29

M

Maintenance 15

Making course changes 10

N

Navigator (Track) mode 12

Audible alarms 14

Entering Navigator mode 12

Exiting Navigator mode 13

Turning to next waypoint 13

Waypoint arrival and advance 13

NMEA cabling 38

O

Operating modes

Auto mode 9

Navigator (Track) mode 12

Standby mode 10

P

Parts supplied 20

Power cabling 37

Product support 16

R

Rotary rudder position sensor

Installation 29–36

Rudder position sensor

Installation 26–36

Linear installation 26–29

Rotary installation 29–36

S

SeaTalk cabling 39

Servicing 15

EMC guidelines 15

SportPilot installation 40–50

Step 1 - Remove steering wheel 41

Step 2 - Mount torque bracket 42

Step 3 - Plug-in cables 45

Step 4 - Secure SportPilot 47

Switching off 9

Switching on 9

T

Track mode

see Navigator (Track) mode

W

Waypoint arrival and advance 13

Limited Warranty Certificate

Raymarine warrants each new Light Marine/Dealer Distributor Product to be of good materials and workmanship, and will repair or exchange any parts proven to be defective in material and workmanship under normal use for a period of 2 years/24 months from date of sale to end user, except as provided below.

Defects will be corrected by Raymarine or an authorized Raymarine dealer. Raymarine will, except as provided below, accept labor cost for a period of 2 years/24 months from the date of sale to end user. During this period, except for certain products, travel costs (auto mileage and tolls) up to 100 round trip highway miles (160 kilometres) and travel time of 2 hours, will be assumed by Raymarine only on products where proof of installation or commission by authorized service agents, can be shown.

Warranty Limitations

Raymarine Warranty policy does not apply to equipment which has been subjected to accident, abuse or misuse, shipping damage, alterations, corrosion, incorrect and/or non-authorized service, or equipment on which the serial number has been altered, mutilated or removed.

Except where Raymarine or its authorized dealer has performed the installation, it assumes no responsibility for damage incurred during installation.

This Warranty does not cover routine system checkouts or alignment/calibration, unless required by replacement of part(s) in the area being aligned.

A suitable proof of purchase, showing date, place, and serial number must be made available to Raymarine or authorized service agent at the time of request for Warranty service.

Consumable items, (such as: Chart paper, lamps, fuses, batteries, styli, stylus/drive belts, radar mixer crystals/diodes, snap-in impeller carriers, impellers, impeller bearings, and impeller shaft) are specifically excluded from this Warranty.

Magnetrons, Cathode Ray Tubes (CRT), TFT Liquid Crystal Displays (LCD) and cold cathode fluorescent lamps (CCFL), hailer horns and transducers are warranted for 1 year/12 months from date of sale. These items must be returned to a Raymarine facility.

All costs associated with transducer replacement, other than the cost of the transducer itself, are specifically excluded from this Warranty.

Overtime premium labor portion of services outside of normal working hours is not covered by this Warranty.

Travel cost allowance on certain products with a suggested retail price below \$2500.00 is not authorized. When/or if repairs are necessary, these products must be forwarded to a Raymarine facility or an authorized dealer at owner's expense will be returned via surface carrier at no cost to the owner.

Travel costs other than auto mileage, tolls and two (2) hours travel time, are specifically excluded on all products. Travel costs which are excluded from the coverage of this Warranty include but are not limited to: taxi, launch fees, aircraft rental, subsistence, customs, shipping and communication charges etc. Travel costs, mileage and time, in excess to that allowed must have prior approval in writing.

TO THE EXTENT CONSISTENT WITH STATE AND FEDERAL LAW:

(1) THIS WARRANTY IS STRICTLY LIMITED TO THE TERMS INDICATED HEREIN, AND NO OTHER WARRANTIES OR REMEDIES SHALL BE BINDING ON RAYMARINE INCLUDING WITHOUT LIMITATION ANY WARRANTIES OF MERCHANTABILITY OR FITNESS FOR A PARTICULAR PURPOSE.

(2) Raymarine shall not be liable for any incidental, consequential or special (including punitive or multiple) damages.

All Raymarine products sold or provided hereunder are merely aids to navigation. It is the responsibility of the user to exercise discretion and proper navigational skill independent of any Raymarine equipment.

Raymarine

Factory Service Centers

United States of America

Raymarine Inc
22 Cotton Road, Unit D
Nashua, NH 03063-4219, USA

Telephone: +1 603 881 5200
Fax: +1 603 864 4756
www.raymarine.com

Sales & Order Services

Telephone: +1 800 539 5539 Ext. 2333 or
+1 603 881 5200 Ext. 2333

Technical Support

Telephone: +1 800 539 5539 Ext. 2444 or
+1 603 881 5200 Ext. 2444
Email: techsupport@raymarine.com

Product Repair Center

Telephone: +1 800 539 5539 Ext. 2118

UK, Europe, Middle East, Far East

Raymarine Ltd
Anchorage Park, Portsmouth
PO3 5TD, England

Telephone: +44 (0)23 9269 3611
Fax: +44 (0)23 9269 4642
www.raymarine.com

Customer Support

Telephone: +44 (0)23 9271 4713
Fax: +44 (0)23 9266 1228

Email: techsupport@raymarine.com

Stick barcode label here

Purchased from

Purchase date

Dealer address

Installed by

Installation date

Commissioned by

Commissioning date

Owner's name

Mailing address

This portion should be completed and retained by the owner.