

Distributed by
Raymarine

Any reference to Raytheon or RTN in this manual should be interpreted as Raymarine. The names Raytheon and RTN are owned by the Raytheon Company.

ST5000 Plus

SailPilot

Owner's

Handbook

Document number: 81136-4
Date: May 2001

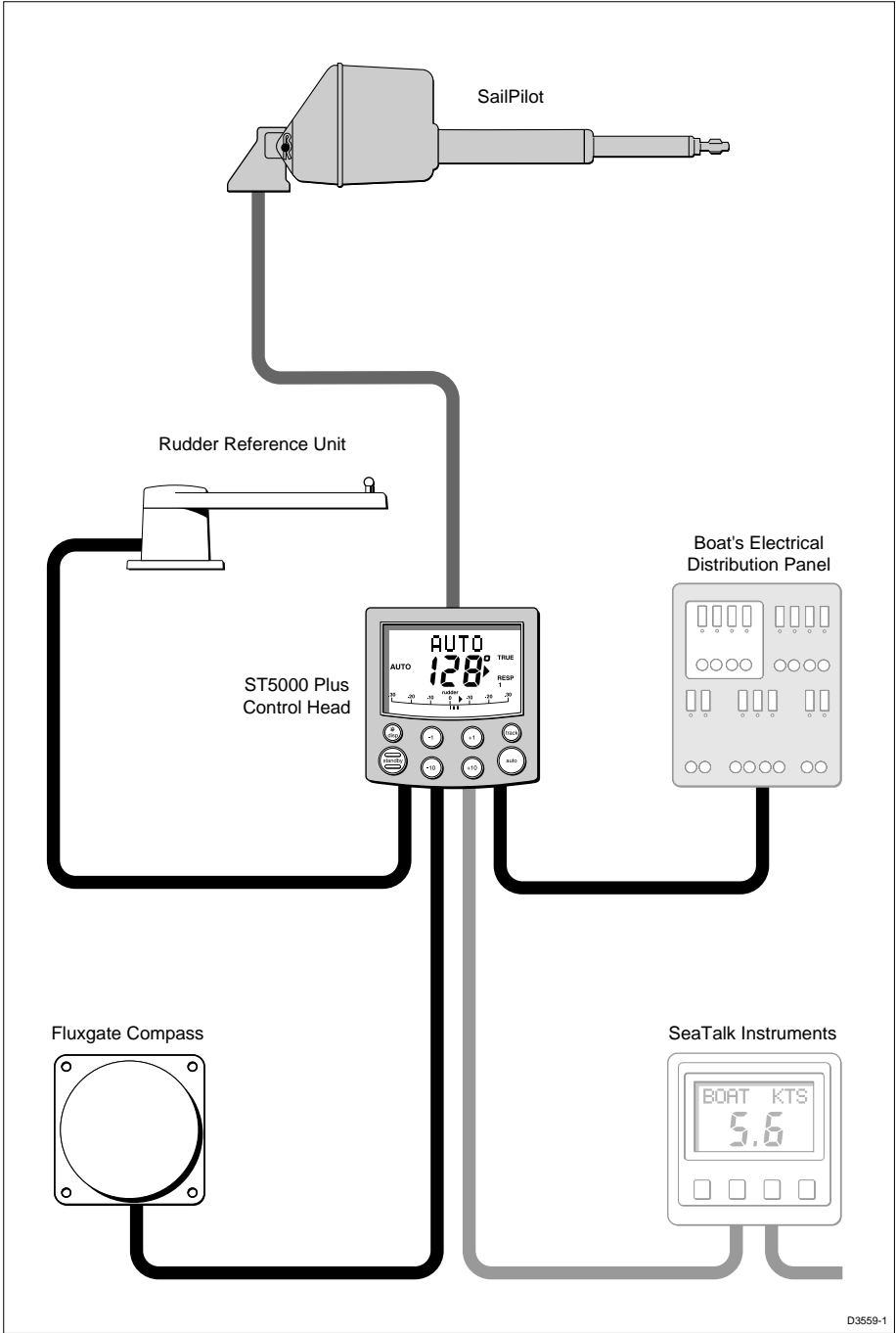

Raymarine, as part of its commitment to continuous improvement and updating, reserves the right to make changes, without prior notice, to the equipment, equipment specifications, and the instructions contained within this handbook.

To the best of our knowledge, the information contained within this handbook was correct as it went to press.

A great deal of care has been taken to ensure that this handbook is as accurate as possible. However, liability cannot be accepted for inaccuracies or omissions.

Autohelm and SeaTalk are registered trademarks of Raymarine Ltd.

WindTrim, AutoTack, AutoTrim, Auto Seastate, Autoadapt and Auto Dockside are trademarks of Raymarine Ltd.

Copyright © Raymarine Ltd 2001.

Contents

- Preface ix**
 - How this handbook is organised ix
 - Warranty ix
 - Safety information x
 - EMC conformance x

- Chapter 1: Introduction 1**
 - 1.1 Overview 1
 - 1.2 Extended systems 2
 - 1.3 Specification 2

- Chapter 2: Basic Operation 3**
 - 2.1 Key functions 3
 - 2.2 Display layout 4
 - 2.3 Using Auto mode 5
 - Engaging the Autopilot (Auto) 5
 - Disengaging the autopilot (Standby) to return to hand steering 5
 - Changing course in Auto mode 6
 - Dodging obstacles in Auto mode 6
 - Returning to the previous locked heading 7
 - Automatic tack (AutoTack) 7
 - AutoTack to starboard 8
 - AutoTack to port 8
 - Off course alarm 8
 - Operating hints 9
 - Making major course changes 9
 - Course changes under autopilot control 9
 - Gusty conditions 10
 - 2.4 Display and keypad illumination 10
 - 2.5 Data pages 11

Chapter 3: Advanced Operation	13
3.1 Operation in Track mode	13
Initiating Track mode	13
Automatic acquisition	14
Manual acquisition	15
Cross track error	16
Tidal stream compensation	16
Waypoint arrival and advance	17
Arrival	17
Skipping a waypoint – SeaTalk navigators only ..	18
Advance	18
Dodges	18
Initiating a dodge manoeuvre	18
Cancelling a dodge manoeuvre	18
Safety	18
Position confirmation at the start of a passage	19
Verifying computed positions	19
Plot frequency	19
Setting waypoints	19
General	19
3.2 Operation in Vane mode (WindTrim)	19
Selecting Vane mode	20
Adjusting the locked wind angle	20
Returning to the previous apparent wind angle	21
Dodges	21
Wind shift alarm	21
Using AutoTack in Vane mode	22
Operating hints	23
3.3 Adjusting autopilot performance	23
Changing the response level (AutoSeastate)	23
Changing the rudder gain	24

3.4 Alarms	24
SeaTalk failure	24
Off course	24
Wind shift	25
Large cross track error	25
Drive stopped	25
Data not received	25
Waypoint advance	26
Low battery	26
Watch alarm	26
Shallow alarm	27
Man overboard (MOB)	27

Chapter 4: Customising the ST5000 Plus 29

4.1 User setup	29
Compass deviation correction	31
Deviation display	31
Heading alignment	31
Heading mode	31
Bar selection	31
Data pages	32
4.2 Dealer setup	34
Calibration lock	36
Pilot type	36
Rudder gain	37
Response	37
Turn limit	37
Align rudder (Rudder Offset)	37
Rudder limit	37
Off Course alarm	38
AutoTack angle	38
AutoTrim	38

Drive type	39
Variation	39
AutoAdapt	39
Latitude	40
Rudder damping	40
Cruise speed	40
Chapter 5: Installation	41
5.1 Planning the installation	41
EMC installation guidelines	41
Suppression Ferrites	42
Connections to other equipment	42
Cabling	42
5.2 Control head	43
Siting	43
Mounting procedure	43
Surface mounting	44
Flush mounting	45
Cable connectors	46
Power supply connection	46
Connection to the SeaTalk bus	47
SeaTalk Cables	47
Cable Types	48
Typical SeaTalk Cabling	48
5.3 Fluxgate compass	48
Mounting location for steel-hulled vessels	49
Installing the fluxgate compass	50
Cabling	51
5.4 Rudder reference transducer	51
Mounting position	51
Control dimensions	52
Installing the rudder reference transducer	52
Cabling	53

5.5 SailPilot linear drive installation	54
Mounting the drive unit	55
Drive unit cabling	56
5.6 NMEA interface	57
Cabling	57
NMEA data transmission to other equipment	57
Data formats	58
Transmission of NMEA data on SeaTalk	58
Chapter 6: Post Installation Procedures	59
6.1 Functional test	59
Switch on	59
Operating sense	60
Navigation interface (GPS, Decca, Loran)	60
Wind transducer interface	61
SeaTalk interface	61
6.2 Dockside procedure	62
6.3 Initial sea trial	62
EMC conformance	62
Overview	62
Automatic compass deviation correction	63
Further heading alignment adjustment	67
Checking autopilot operation	67
Checking the rudder gain	67
Chapter 7: Maintenance	71
General	71
Servicing and Safety	71
Advice	71
Chapter 8: Fault Finding	73
Index	75

Preface

This handbook contains information on the operation and installation of your new equipment. In order to obtain the best performance from your autopilot, please read this handbook thoroughly.

How this handbook is organised

This handbook is divided into the following chapters:

Chapter 1: Introduces the autopilot, its features and its use.

Chapter 2: Covers basic autopilot operation.

Chapter 3: Explains how to use Track and Vane (WindTrim) modes and adjust autopilot performance, and summarises the ST5000 Plus alarms.

Chapter 4: Provides details on how to make adjustments to customise the autopilot to your particular vessel.

Chapter 5: Explains how to install your autopilot and its components.

Chapter 6: Covers functional testing and dockside procedures after installation, and initial sea trials.

Chapter 7: Provides general maintenance procedures.

Chapter 8: Provides information to help you resolve any problems you may encounter with your autopilot.

An index is included at the end of this handbook, followed by templates for the installation of the control head, SeaTalk deck connector and rudder reference transducer.

Warranty

To verify the ownership of your new autopilot, please take a few minutes to complete the warranty card. It is important that you complete the owner information and return the card to the factory to receive full warranty benefits.

Safety information

Passage making under autopilot control is an enjoyable experience that can, if you are not careful, lead to the relaxation of the permanent watch. A permanent watch **MUST** be maintained no matter how clear the sea may appear to be.

Remember, a large ship can travel two miles in five minutes – just the time it takes to make a cup of coffee.

The following rules should always be observed:

- Maintain a permanent watch and regularly check all around for other vessels and obstacles to navigation – no matter how clear the sea may appear a dangerous situation can develop rapidly.
- Maintain an accurate record of the vessel's position either by use of a radio navigation receiver or visual bearings.
- Maintain a continuous plot of position on a current chart. Ensure the locked autopilot heading steers you clear of all obstacles. Make proper allowance for Tidal Set – the autopilot cannot!
- Even when your autopilot is locked onto the desired Track using a radio navigation receiver, always maintain a log and make regular positional plots. Radio navigation signals can produce significant errors under some circumstances and the autopilot cannot detect this situation.
- Make sure that all members of crew are familiar with the procedures to disengage the autopilot.

Your Raymarine autopilot will add a new dimension to your boating enjoyment. However, it is the responsibility of the skipper to ensure the safety of the vessel at all times by careful observance of these basic rules.

EMC conformance

All Raymarine equipment and accessories are designed to the best industry standards for use in the leisure marine environment.

Their design and manufacture conforms to the appropriate Electromagnetic Compatibility (EMC) standards, but correct installation is required to ensure that performance is not compromised.

Chapter 1: Introduction

1.1 Overview

The ST5000 Plus is a SeaTalk® compatible autopilot available for SailPilot linear drive steering systems, which can also repeat instrument data in a programmable selection of Data Pages.

The ST5000 Plus can share all data transmitted from other Raymarine SeaTalk instruments:

- Wind information from a wind instrument can be used for wind trim (Vane) steering without the need to install a separate vane.
- Track information, from a navigation instrument, provides waypoint control from the autopilot.
- Boat speed from the Speed instrument provides optimum track-keeping performance.

The ST5000 Plus autopilot can also be used with any navigator (GPS, Decca, Loran) transmitting NMEA 0183 data.

There are four operating modes:

Standby: Autopilot disengaged

Auto: Autopilot engaged and locked onto a heading

Track: Autopilot maintains a track between two waypoints created using a navigation system

Vane: Autopilot maintains a course relative to an apparent wind angle

When the ST5000 Plus is being used to repeat instrument data, “pop-up pilot” pages are displayed for 5 seconds whenever a change in autopilot control is made.

The ST5000 Plus also provides the following:

- Automatic tack facility, which can be used in Auto and Vane modes
- Automatic compass deviation correction
- Northerly/Southerly heading compensation
- Automatic heading deadband – seastate control
- Waypoint advance feature
- Setup and calibration options to suit each installation, giving maximum performance with many types of boat, with three calibration menus (user, intermediate and dealer)

1.2 Extended systems

The ST5000 Plus is compatible with other Raymarine SeaTalk instruments.

Additional fixed and hand-held SeaTalk autopilot control units can be connected at secondary steering and control positions.

1.3 Specification

- Power Supply: 10 to 15 V dc
- Drive mechanism: Linear drive unit, high current FET drive
- Current consumption:
Standby: 60 mA (less than 200 mA with full lighting)
Auto: between 0.5 A and 1.5 A depending on drive type, boat trim, helm load and sailing conditions
- Operating temperature: 0°C to +70°C (32°F to 158°F)
- Eight button illuminated digital keypad
- LCD display of heading, locked course and navigational data, with three levels of illumination
- Input connections for SeaTalk, power, fluxgate compass, rudder reference unit and NMEA
- Output connections for: SeaTalk, clutch drive and motor drive
- Clutch current limit: 2 A

Chapter 2: Basic Operation

This chapter first provides summary diagrams of the key functions and screen layout. It then gives operating instructions for engaging the autopilot and using Auto mode, changing the lighting, and displaying Data Pages.

2.1 Key functions

The autopilot is controlled using simple push-button operations, all of which are confirmed with a beep. In addition to the main single key functions, there are several dual key functions.

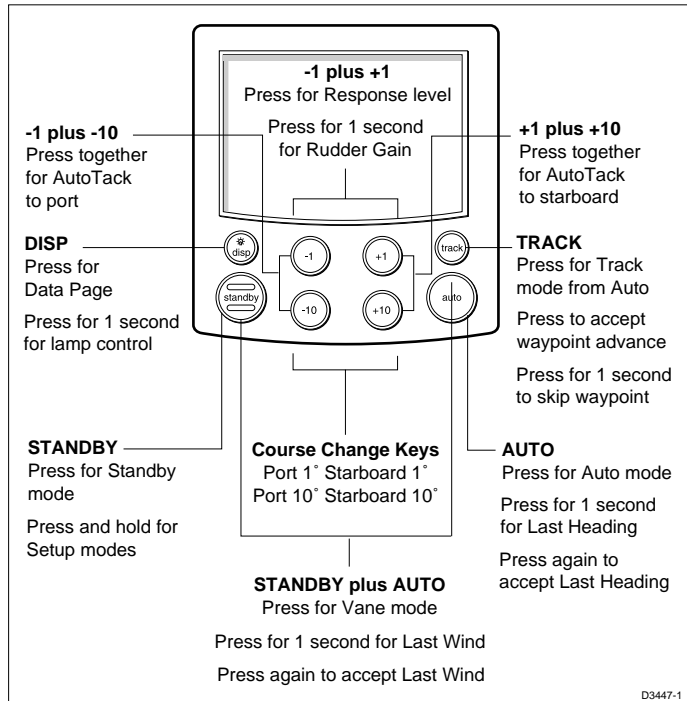

- The autopilot always powers up in Standby mode.
- Course changes can be made at any time using the **-1, +1, -10** and **+10** keys.
- You can return to manual steering at any time by pressing **standby**.

2.2 Display layout

The following illustration shows all the elements, together with a brief description, that make up the ST5000 Plus autopilot LCD display.

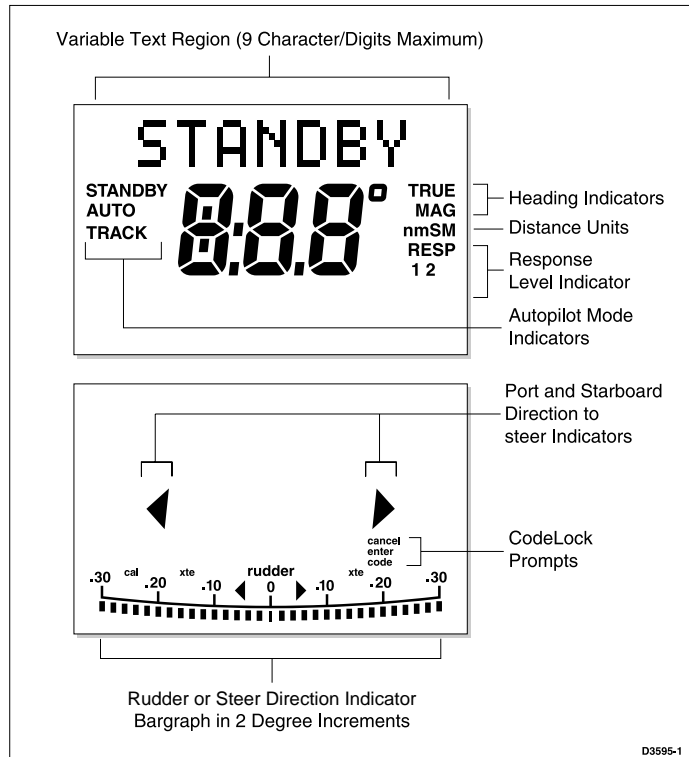

- The bar graph at the bottom of the display is normally a rudder bar. If it has been set as a direction-to-steer indicator, the display depends on the current mode, as follows:

Mode	Bar
Standby	Rudder bar for systems with a rudder reference transducer
Auto	Heading error bar
Track	Cross track error (XTE) bar, in 0.02 nm increments
Vane	Wind angle error bar

- If neither distance units (nm or SM) is displayed, the distance is in Km.

2.3 Using Auto mode

Engaging the Autopilot (Auto)

1. Steady the vessel on the required heading.
2. Press **auto**.

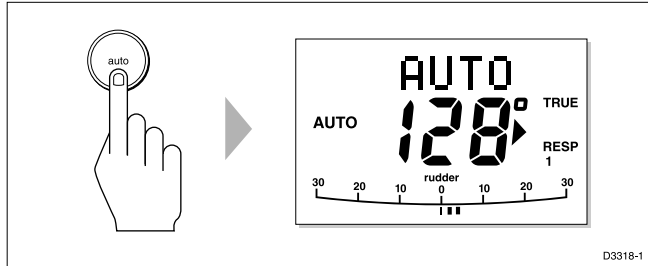

- In Auto mode, the display shows the locked autopilot heading.

CAUTION:

Passage making under autopilot control is an enjoyable experience that can, if you are not careful, lead to the relaxation of the permanent watch. A permanent watch **MUST** be maintained no matter how clear the sea may appear to be.

Remember, a large ship can travel two miles in five minutes – just the time it takes to make a cup of coffee.

Disengaging the autopilot (Standby) to return to hand steering

- Press **standby**.

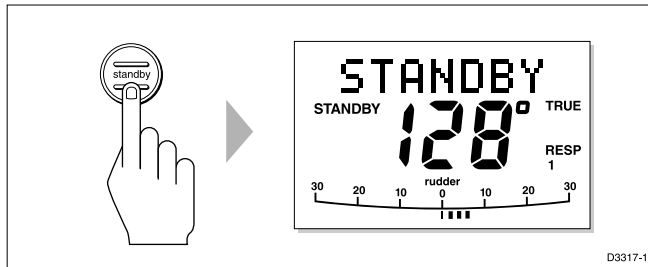

- In Standby mode, the display shows the vessel's current compass heading.
- The previous autopilot heading is memorised and can be recalled (see below).

Changing course in Auto mode

The **+1** and **+10** (starboard) and **-1** and **-10** (port) keys are used to change the locked heading, in increments of 1° and 10° , when the autopilot has control.

Example: a 30° course change to port = press **-10** three times.

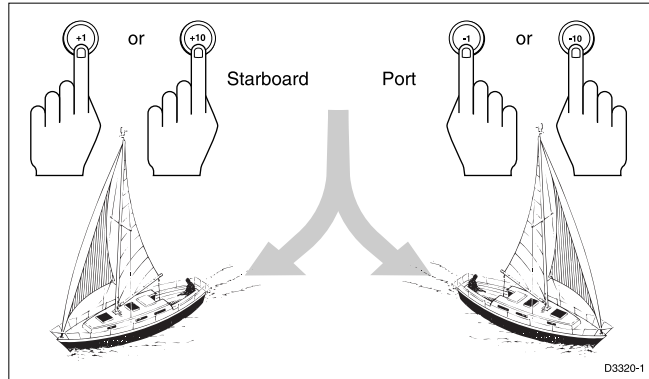

Dodging obstacles in Auto mode

In order to avoid an obstacle when your vessel is under autopilot control, select a course change in the appropriate direction (for example, port 30° = press **-10** three times).

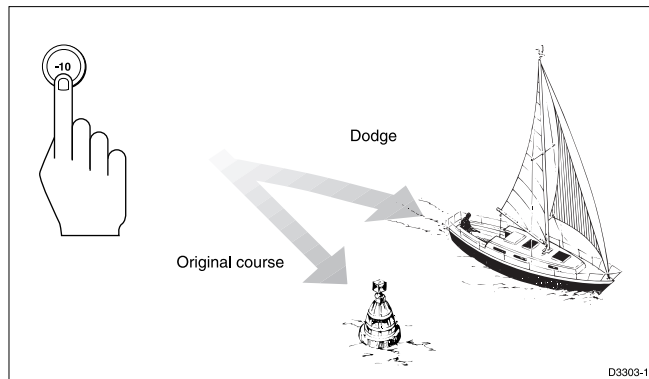

When safely clear of the obstacle, you can reverse the previous course change (for example, press **+10** three times), or return to the previous locked heading (LAST HDG).

Returning to the previous locked heading (LAST HDG)

If for any reason the vessel is steered away from the selected locked heading (for example, executing a dodge manoeuvre or selecting Standby) you can return to the previous locked heading:

1. Press **auto** for 1 second. The previous locked heading (LAST HDG) is displayed for 7 seconds.

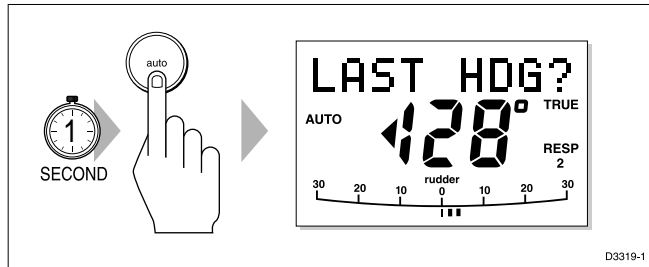

Note: A direction-to-steer indicator is displayed to show you the direction the vessel will turn.

2. To accept this heading, and resume the original course, press **auto** once within this 7 second period.

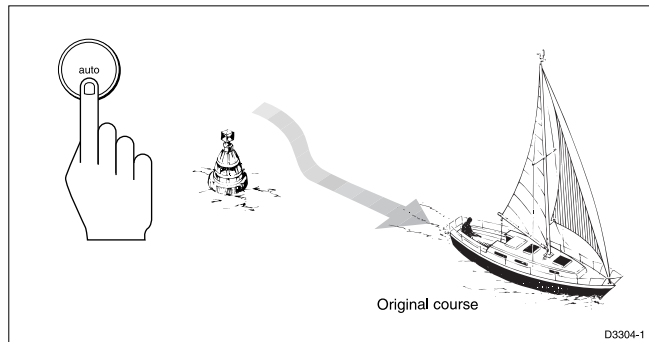

If you do not press **auto** while the display is flashing, the current heading will be maintained.

Automatic tack (AutoTack)

The ST5000 Plus has a built in automatic tack facility that turns the vessel through a predetermined angle (the factory default is 100°) in the required direction.

AutoTack to starboard

Press the **+1** and **+10** keys together to tack to starboard.

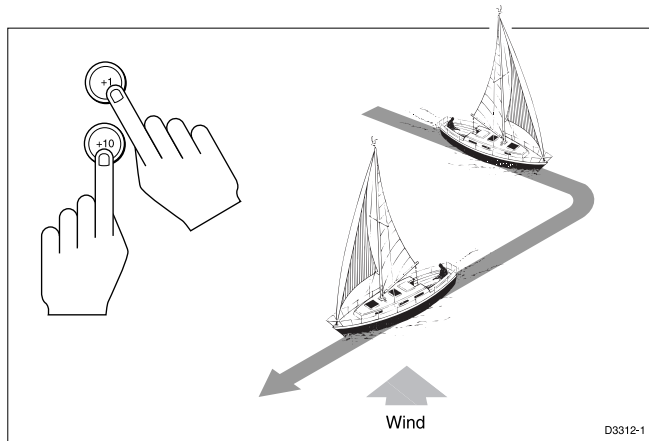

AutoTack to port

Press the **-1** and **-10** keys together to tack to port.

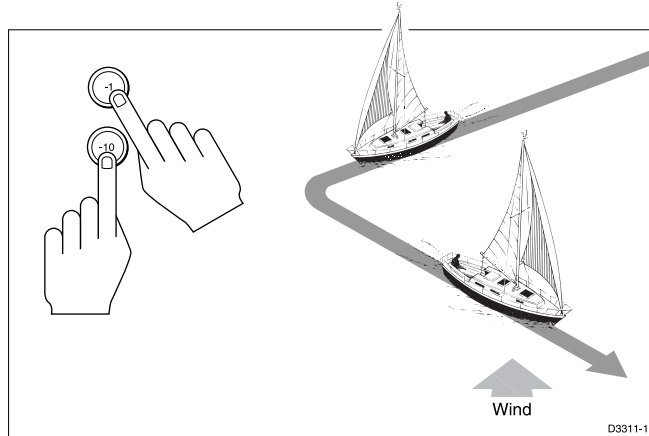

Off course alarm

The off course alarm will sound if the locked autopilot heading and the vessel's current heading differ for more than 20 seconds, by more than the alarm angle set in calibration (the factory default is 20°).

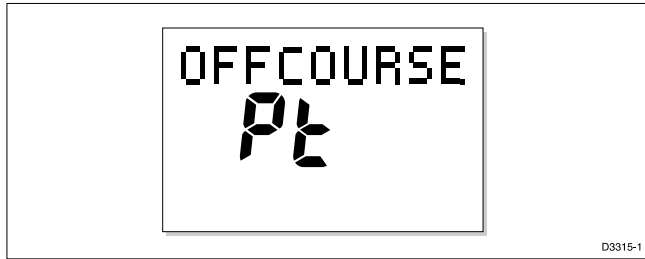

1. To cancel the off course alarm, press **standby** to return to hand steering.
2. Check whether your vessel is carrying too much sail, or whether the sails are badly balanced. Significant improvements in course keeping can usually be obtained by improving sail balance.

Operating hints

Making major course changes

- It is sound seamanship to make major course changes only when steering manually.
- Manual course changes ensure that obstructions or other vessels can be cleared properly, and due account taken of the changed wind and sea conditions on the new heading prior to engaging the autopilot.

Course changes under autopilot control

It is important to understand the effect of sudden trim changes on steering performance. When a sudden trim change occurs, due, for example, to weather helm or sail imbalance, there will be a delay before the automatic trim applies rudder to restore the locked heading. This correction can take up to one minute.

Large course changes which change the apparent wind direction can produce large trim changes. In these situations, the autopilot will not immediately assume the new automatic heading, and will only settle onto course when the automatic trim has been fully established.

To eliminate this problem, the following procedure can be adopted for large course changes:

1. Note the required new heading.
2. Select **standby** and steer manually.

3. Bring the vessel onto the new heading.
4. Select **auto** and let the vessel settle onto course.
5. Bring the vessel to the final course with 1° increments.

Gusty conditions

In gusting conditions, the course may tend to wander slightly, particularly if the sails are badly balanced. A significant improvement in course keeping can always be obtained by improving sail balance. Bear in mind the following important points:

- Do not allow the yacht to heel over excessively
- Ease the mainsheet traveller to leeward to reduce heeling and weather helm
- If necessary, reef the mainsail a little early

It is also advisable, whenever possible, to avoid sailing with the wind dead astern in very strong winds and large seas.

Ideally, the wind should be brought at least 30° away from a dead run and, in severe conditions, it may be advisable to remove the mainsail altogether and sail under headsail only.

Provided these simple precautions are taken, the autopilot will be able to maintain competent control in gale force conditions.

2.4 Display and keypad illumination

- Press **disp** for 1 second, from any mode, to enter illumination adjustment mode and turn the lights on.

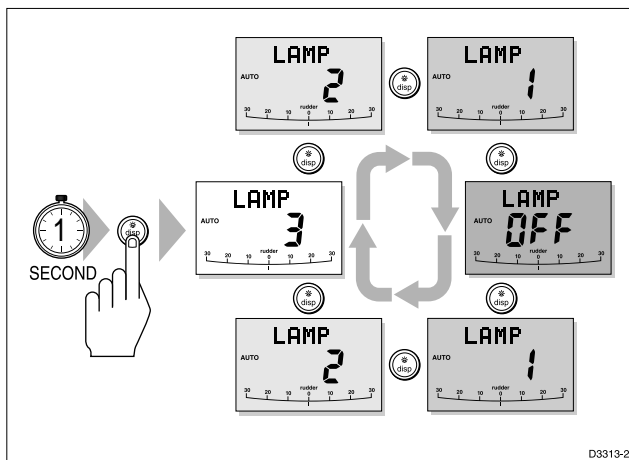

- Subsequent presses of the **disp** key cycles the possible illumination settings: L3, L2, L1, OFF, L1, L2, L3 etc. where L3 is the brightest setting.

The display times out to normal operation after 7 seconds of keypad inactivity.

Pressing any other key before the 7 second time-out will select the mode assigned to that key (for example, **auto** selects Auto mode, **standby** selects Standby mode).

Notes: If other SeaTalk instruments or autopilot control units are connected to SeaTalk, the illumination can be adjusted from these units.

Any adjustments to the illumination are lost when the unit is switched off.

The keys are still lit at a courtesy level when the display lighting is off.

2.5 Data pages

The **disp** key is used to cycle “pages” of SeaTalk or NMEA data. Once a Data Page is selected, this page becomes the principle autopilot display. The autopilot mode displays (Standby, Auto, Track and Vane) then become “pop-ups”, and are displayed for 5 seconds when the autopilot mode is changed or a course change is made.

- Press **disp** to display each Data Page in turn.
- When the last Data Page is cycled, the display returns to the current autopilot mode display (for example, Standby).
- To return to a previous Data Page, press **disp** for 1 second within 2 seconds of displaying a page. You can continue to move backwards through the Data Page sequence in this way.

The following illustration shows the default settings for the Data Pages.

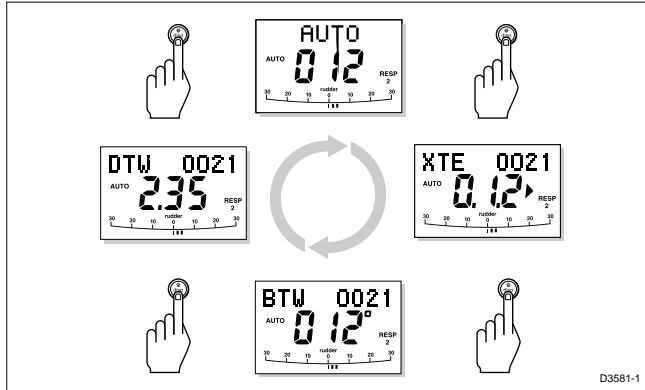

Up to 7 Data Pages are available using the **disp** key. The number of pages, and the information displayed on each page, depends on the selections made in User Setup (see section 5.1).

- If the required data for a page is not available, dashes are displayed instead of a value.
- Most displays are repeated data, and cannot be adjusted. The exceptions are the Response and Rudder Gain pages (if selected for display), which can be adjusted using the **+1** and **-1** keys.
- The current autopilot mode is shown at the left of the display, and the autopilot bar graph remains in use.
- The “direction-to-steer” arrows relate to the Data Page information.

Chapter 3: Advanced Operation

This chapter provides information on:

- Operation in Track mode
- Operation in Vane mode (WindTrim)
- Adjusting the response level and rudder gain
- Alarms

3.1 Operation in Track mode

Track mode is used to maintain a track between two waypoints created on a GPS, Decca, or Loran navigation system. The ST5000 Plus will then compute any course changes to keep your boat on track, automatically compensating for tidal streams and leeway.

The ST5000 Plus can receive cross track error (the distance your vessel is from a planned track) from:

(a) A SeaTalk navigation instrument or chartplotter

or

(b) A non-SeaTalk navigation system transmitting data in the NMEA 0183 format – this can be connected directly to the ST5000 Plus NMEA input, as described in the Installation Chapter.

Track mode is selected by pressing the **track** key, but can only be selected from Auto mode. You can return to either Auto or Standby mode from Track mode, as follows:

- Press **auto** to leave Track mode and return to Auto mode.
- Press **standby** to leave Track mode and return to manual steering.

Initiating Track mode

When initiating Track mode, the track can be acquired in one of two ways:

- Automatic acquisition, when cross track error and bearing to waypoint data are available
- Manual acquisition, when cross track error is the only available data

Automatic acquisition

Automatic acquisition can only be achieved if the pilot is receiving cross track error and bearing to waypoint information (via SeaTalk or NMEA 0183). It is initiated as follows:

1. Bring the vessel to within 0.1 nm of track.
2. Press **auto**.
3. Press **track** to enter Track mode, with the current locked heading displayed. After a short delay for data acquisition, the Waypoint Advance alarm will sound, and the display will show the planned bearing to waypoint alternating with the direction in which the boat will turn.

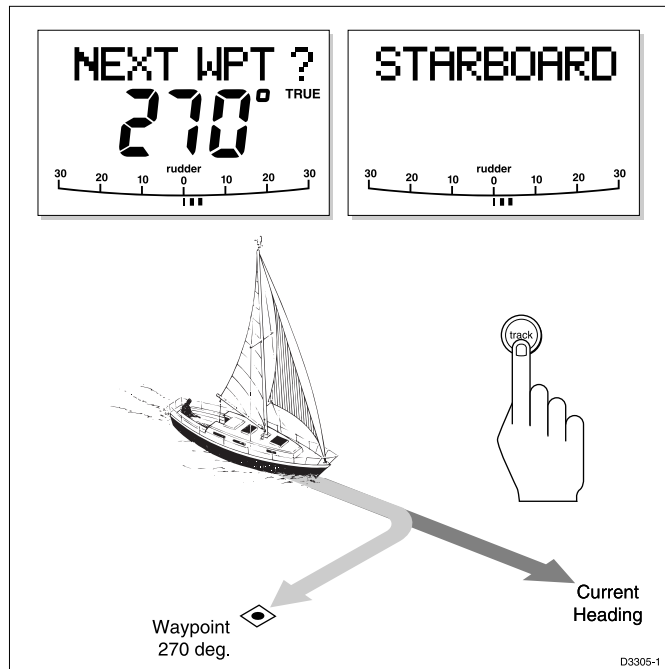

Note: *If the vessel is further than 0.3 nm from the track, the Large Cross Track Error alarm will sound. Press **standby** to cancel the alarm, hand steer closer to the track, and press **auto** and **track** again.*

4. Check that it is safe to turn onto the new course.
5. Press the **track** key. The boat will turn onto the new course and the alarm will be cancelled.

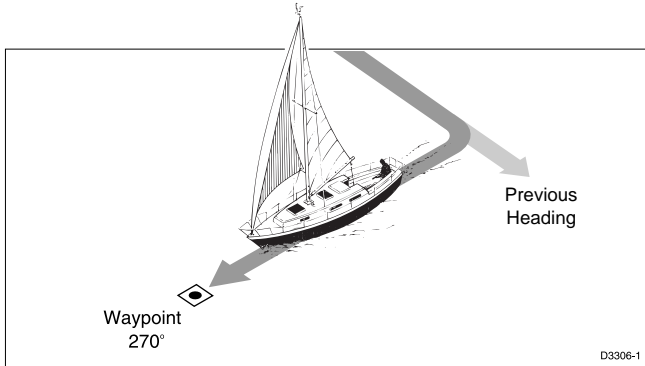
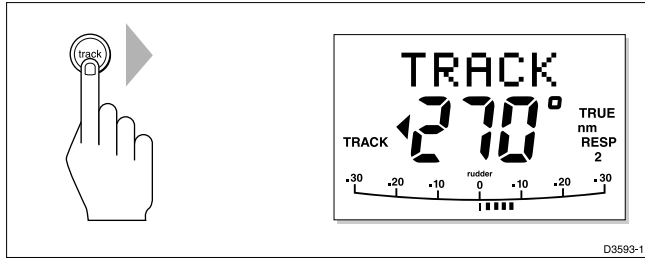

- The display shows the new bearing to waypoint.

Manual acquisition

For manual track acquisition, when only cross track error data is available:

1. Steer the vessel to within 0.1 nm of track.
 2. Bring the heading to within 5° of the bearing to the next waypoint.
 3. Press **auto**.
 4. Press **track** to enter Track mode.
- The display shows the locked pilot heading.

Note: *At low speeds, the effect of tidal streams is far more significant than it is at higher speeds. Provided the tidal flow is less than 35% of the vessel's speed, no noticeable difference should occur in the performance of Track mode. However, extra care should be taken during manual acquisition, as follows:*

- *Ensure that the vessel is as close as possible to track, and the direction made good over the ground is as close as possible to the direction of the next waypoint, before selecting Track mode.*
- *Make positive positional checks at regular intervals, especially if navigational hazards are close by.*

Cross track error

Cross track error (XTE) is the distance between the current position and a planned route. This is displayed in nautical miles (nm), statute miles (SM) or kilometres, and is taken directly from your navigator.

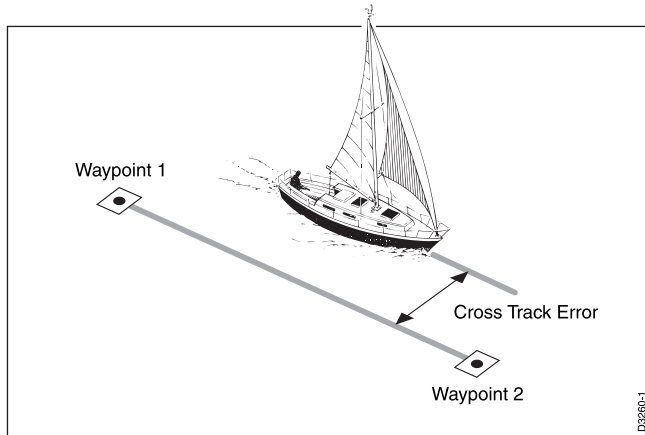

The Large XTE alarm sounds if the XTE exceeds 0.3 nm

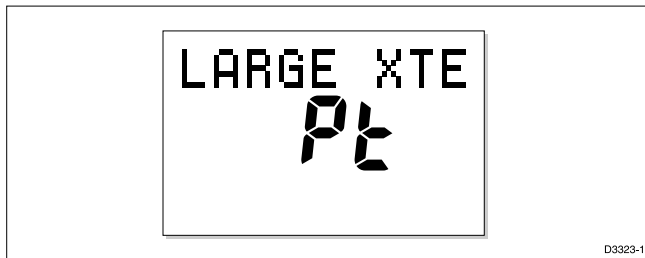

- The direction of the error is identified as port (**Pt**) or starboard (**Stb**).
- To cancel the alarm and leave track mode, press **standby** to return to hand steering, or **auto** to return to Auto mode and retain the current heading.

Note: *If the Large XTE alarm sounds, it is usually an indication that the cross tide is too great for the vessel's current speed.*

Tidal stream compensation

Under most conditions, Track mode will hold the selected track to within ± 0.05 nm (300 ft) or better.

The autopilot takes account of vessel speed when computing course changes to ensure optimum performance over a wide range of vessel speeds. If speed data is available, the ST5000 Plus uses the measured vessel speed. Otherwise, the Speed Over Ground (SOG) or specified cruise speed is used, depending on the calibration setting (see *Dealer Setup* in Chapter 4).

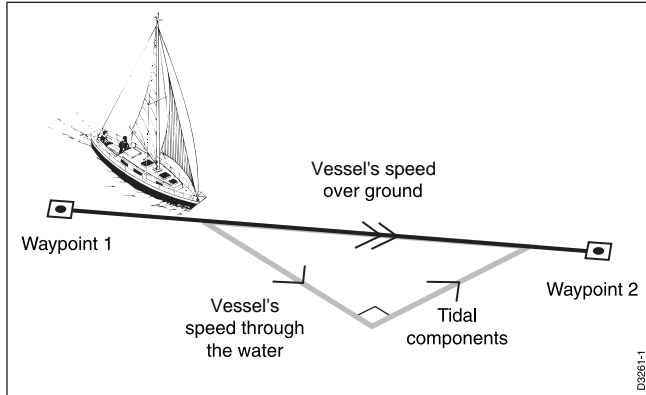

Waypoint arrival and advance

Arrival

As the vessel arrives at the target waypoint, the navigation receiver should select (manually or automatically) the next target waypoint.

The ST5000 Plus detects the new target waypoint number, sounds the Waypoint Advance alarm and displays the Waypoint Advance information. This display shows the new bearing to waypoint and the direction the boat will turn to acquire the new track.

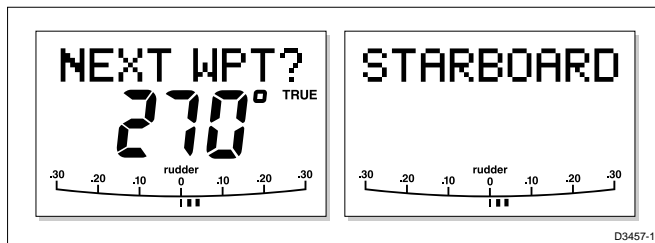

To accept to the new target waypoint, press **track**.

Note: When you reach the last waypoint in the track, the *NO DATA* alarm will sound to indicate that there is no further waypoint information. Press **auto** to continue on the same heading, or **standby** to return to hand steering.

Skipping a waypoint – SeaTalk navigators only

If you wish to advance to the next waypoint before you have arrived at the target waypoint, press **track** for 1 second. The Waypoint Advance information for the next waypoint is displayed.

Advance

While the Waypoint Advance alarm is sounding, Track mode is suspended and the ST5000 Plus maintains the current boat heading.

1. Check that it is safe to turn onto the new track.
2. Press the **track** key. This will cancel the Waypoint Advance alarm and turn the boat towards the next waypoint.

Note: *Unless the Waypoint Advance is accepted in the above manner, the alarm will continue to sound and the current heading will be maintained.*

Dodges

Full control is still available from the keypad when the autopilot is in Track mode.

Initiating a dodge manoeuvre

In Track mode, dodge manoeuvres are accomplished by simply selecting the desired course change using the course change keys (**-1**, **+1**, **-10** or **+10**).

Cancelling a dodge manoeuvre

Once the hazard has been avoided, the course change selected for the dodge manoeuvre should be cancelled by selecting an equal course change in the opposite direction.

Note: *Provided the vessel remains within 0.1 nm of track, there is no need to steer back towards the track.*

Safety

Passage making in Track mode removes the chores of compensating for wind and tidal drift, and will aid precise navigation. However, it is important to maintain an accurate log with regular plots.

Position confirmation at the start of a passage

At the start of a passage you must always confirm the fix given by the position transducer, using an easily identifiable fixed object. Check for fixed positional errors and compensate for them.

Verifying computed positions

- Verify the computed position with a dead reckoned position, calculated from the average course steered and the distance logged.

Plot frequency

- In open water, plots should be at least hourly.
- In confined waters, or when potential hazards are near, plots should be more frequent.
- Local variations in radio signal quality, and changes in the tidal stream, will produce deviations from the desired track.

Setting waypoints

- When setting waypoints, remember that deviations will occur.
- Thoroughly check along each track.
- Check up to 0.5 nm each side of the track to ensure that there are no hazards within the zone.

Note: In order for the waypoint advance function to work successfully, the last four characters of adjacent waypoint names must be different.

General

The use of Track mode will enable accurate track keeping even in complex navigational situations. However, it cannot remove the responsibility of the skipper to ensure the safety of his vessel at all times by careful navigation and frequent position checks.

3.2 Operation in Vane mode (WindTrim)

Vane mode, also known as WindTrim, allows the ST5000 Plus to maintain a course relative to an apparent wind angle. It uses wind trim to eliminate the effects of turbulence and short term wind variations, and provides smooth precise performance under Vane mode operation with minimal power consumption.

Vane mode uses the fluxgate compass as the primary heading reference and, as changes in the apparent wind angle occur, the locked compass heading is adjusted to maintain the original apparent wind angle.

To use Vane mode, the ST5000 Plus must receive wind information from one of the following sources:

- SeaTalk Wind instrument, connected to the ST5000 Plus via SeaTalk
- NMEA wind information
- Raymarine wind vane connected to a SeaTalk interface box

Selecting Vane mode

Vane mode can be selected from either Standby or Auto modes, as follows:

1. Steady the vessel onto the required apparent wind angle.
2. Press **standby** and **auto** together to select Vane mode and lock the current apparent wind angle.

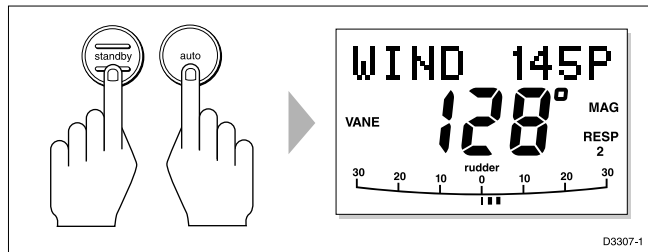

- The locked heading is displayed along with the apparent wind angle.
- The boat heading is adjusted by the ST5000 Plus to maintain the locked apparent wind angle.

Adjusting the locked wind angle

The locked wind angle can be adjusted by changing course using the **-1**, **+1**, **-10** and **+10** keys.

For example, to bear away by 10° when the vessel is on starboard tack, press **-10** to turn the vessel 10° to port. The locked apparent wind angle and locked heading both change by 10°. The new apparent wind angle is maintained, and the locked heading adjusted by the autopilot as required.

Note: *This method should only be used for minor adjustments to the apparent wind angle, since turning the boat affects the relationship between the true and apparent wind angles. For major changes, return to Standby mode, steer onto the new heading, and reselect Vane mode.*

Returning to the previous apparent wind angle (LAST WND)

If for any reason the vessel is steered away from the selected apparent wind angle (for example, a dodge manoeuvre or selecting Standby) you can return to the previous locked wind angle:

1. Press **standby** and **auto** together for 1 second to display the previous apparent wind angle (LAST WND?).

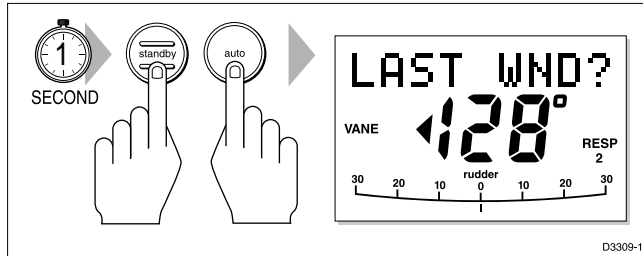

The LAST WND? text alternates with the previous wind angle and direction. The previous locked heading is displayed, with an indicator to show you the direction in which the vessel will turn.

2. Check that it is safe to turn on to this course.
3. To accept this apparent wind angle, press **standby** and **auto** together within 7 seconds.

If you do not accept the previous wind within this time, the autopilot will lock on to the current apparent wind angle.

Dodges

Full control is still available from the keypad when the autopilot is in Vane mode.

- Dodge manoeuvres are accomplished by simply selecting the desired course change using the course change keys (**-1**, **+1**, **-10** or **+10**). Both the locked heading and locked apparent wind angle are adjusted.
- Once the hazard has been avoided, you can reverse the previous course change, or return to the previous wind angle (LAST WND?).

Wind shift alarm

The Wind Shift alarm sounds, and the text WINDSHIFT is displayed, if a wind shift of more than 15° is detected.

- To cancel the alarm and retain the existing wind angle and new heading, press **standby** and **auto** together.
- Alternatively, to cancel the alarm and return to the previous heading, either: adjust the locked wind angle using the **-1**, **+1**, **-10** and **+10** keys; or press **standby** to return to hand steering, steer onto the required heading, and press **standby** and **auto** together to return to Vane mode with the new apparent wind angle.

Using AutoTack in Vane mode

The automatic tack function tacks the vessel through a set angle (the factory default is 100°). The locked heading can then be adjusted until the required apparent wind angle is achieved.

- To tack to starboard, press the **+1** and **+10** keys together.
- To tack to port, press the **-1** and **-10** keys together.

Note: *If you use the Autotack function in Vane mode, it is important to ensure that the wind vane was centred accurately when it was installed.*

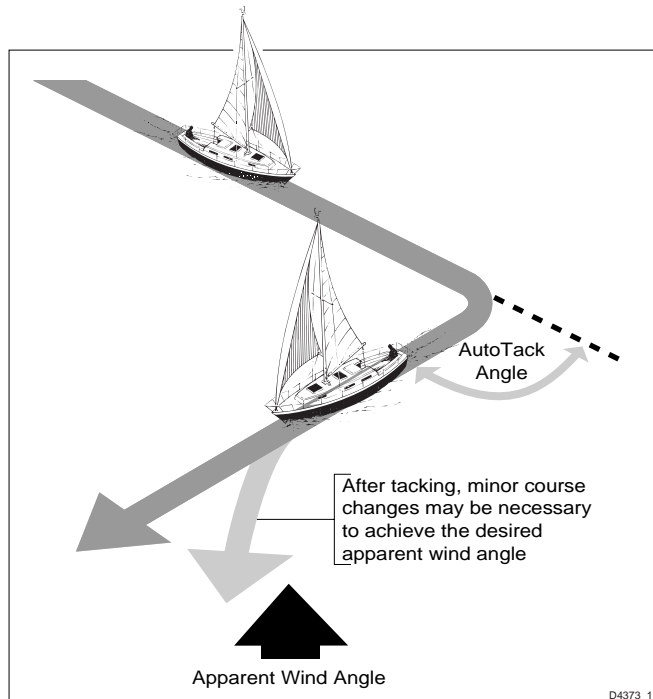

Operating hints

- It is important to ensure that the amount of standing helm is minimised by careful sail trimming.
- The headsail and mainsail should be reefed a little early rather than too late.
- In Vane Mode the pilot will react to long-term wind shifts, but will not correct for short-term changes, such as gusts.
- In gusty and unsteady inshore conditions, it is best to sail a few degrees further off the wind so that changes in apparent wind direction can be tolerated.

3.3 Adjusting autopilot performance

The response level and rudder gain can be adjusted during normal operation using a combined key-press. Alternatively, you can set up these two control displays as default Data Pages (see section 2.5).

The default calibration settings for response level and rudder gain, as specified in Dealer Setup, are restored whenever the system is powered on.

Changing the response level (AutoSeastate)

The response level controls the relationship between the autopilot's course keeping accuracy and the amount of helm/drive activity.

- **Response Level 1**, AutoSeastate (Automatic Deadband), causes the autopilot to gradually ignore repetitive movements of the vessel and only react to true variations in course. This provides the best compromise between power consumption and course keeping accuracy, and is the default calibration setting.
- **Response Level 2** (Minimum Deadband) provides the tightest course keeping possible. However, tighter course keeping results in increased power consumption and drive unit activity.

The response can be changed at any time. To do so:

1. Press the **+1** and **-1** keys together momentarily to display the Response screen.
2. Press **+1** or **-1** to change the response level.
3. Wait for 5 seconds, or press **disp**, to return to the previous display.

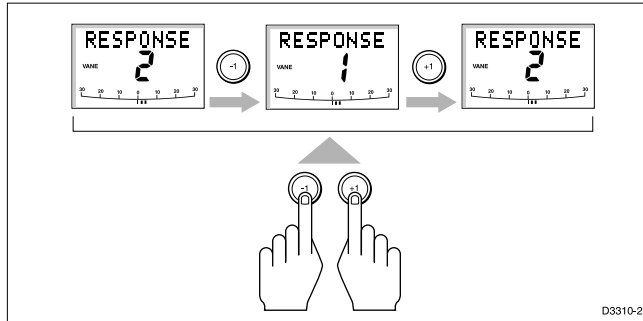

Changing the rudder gain

Press the **+1** and **-1** keys together for 1 second to display the Rudder Gain screen, and adjust the setting in the same way as for the response level. Refer to *Chapter 6, Post Installation Procedures*, for instructions on how to check that the rudder gain is set correctly.

3.4 Alarms

This section summarises the alarms (in order of priority) that are reported by the ST5000 Plus.

Press **standby** to clear an alarm and return to hand steering, unless otherwise stated.

SeaTalk failure

STLK FAIL

This silent alarm indicates that there is a wiring fault in the SeaTalk connection.

Off course

OFFCOURSE

This alarm is activated when the vessel has been off course from the locked heading by more than the specified angle for more than 20 seconds (see *Section 2.3, Using Auto Mode*).

The alarm is cleared if the heading recovers or the course is changed, or if the operating mode is changed.

Wind shift

WINDSHIFT

This alarm is activated when a change in the apparent wind angle of more than 15° is detected (see *Section 3.2, Operation in Vane Mode*).

Large cross track error

LARGE XTE

This alarm is activated when the cross track error exceeds 0.3 nm (see *Section 3.1, Operation in Track Mode*).

The alarm is cleared if the heading recovers or the course is changed, or if the operating mode is changed.

Drive stopped

DRIVESTOP

This alarm is activated if:

- the rudder reference transducer fails.
- the autopilot is unable to turn the rudder. This occurs if the weather load on helm is too high, or if the rudder position is past the preset rudder limits or the rudder end-stops.

Data not received

NO DATA

This alarm is displayed in the following circumstances:

- Compass not connected
- Track mode is engaged and the vessel arrives at the last waypoint in the track
- Track mode is engaged and the autopilot is not receiving SeaTalk navigation data.
- Track mode is engaged and the position transducer (GPS, Loran, Decca) is receiving a low strength signal – this will clear as soon as the signal strength improves.
- Vane mode is engaged and the autopilot has not received wind angle data for 30 seconds.

The autopilot stops adjusting the heading as soon as data is lost.

Waypoint advance

NEXT WPT?

The Waypoint Advance alarm sounds whenever the target waypoint number changes, which occurs in the following circumstances:

- Automatic acquisition is selected by pressing **track** from Auto
- Waypoint advance is requested by pressing **track** for 1 second in Track mode (SeaTalk Navigators only)
- When the vessel arrives at the target waypoint and the navigator accepts the next waypoint
- When the Man Overboard (MOB) function is activated in Track mode.

When the alarm sounds, the pilot continues on its current heading, but displays the bearing to the next waypoint and the direction in which the boat will turn to take up that bearing.

Check that it is safe to turn onto the new track, and press **track** to accept the waypoint advance.

Alternatively, to cancel the alarm without accepting the waypoint advance, press **standby** to return to hand steering, or **auto** to return to Auto mode.

***Note:** The waypoint advance will only operate on pilots receiving valid bearing to waypoint and waypoint number information.*

Low battery

LOW BATT

The Low Battery alarm sounds when the supply voltage drops below 10 V (± 0.5 V).

Press **standby** to clear the alarm and return to hand steering.

Start the engine to recharge the battery.

Watch alarm

WATCH

The Watch alarm is activated in Watch mode when the timer reaches 4 minutes. It is not available from Standby mode.

If you wish to set the Watch mode, the WATCH screen must be configured as one of the Data Pages for display, as described in section 5.1.

To set and control the Watch alarm:

1. Select Auto, Track or Vane mode.
2. Press the **disp** key until the WATCH Data Page is displayed.
 - The watch timer starts counting.
 - When the timer reaches 3 minutes, the text on the display starts flashing to indicate the last minute of Watch alarm.
 - When the timer reaches 4 minutes, the audible Watch alarm is activated.
3. Press **auto** at any time to silence the alarm and reset the timer to 4 minutes. (Pressing any other key resets the timer and performs the key's normal function).
4. To clear Watch mode, press **disp** to display a different page, or press **standby**.

*Note: You cannot engage Auto mode from Watch mode – pressing **auto** only resets the Watch timer.*

Shallow alarm

SHALLOW

The Shallow alarm is activated on the ST5000 Plus if a shallow depth alarm is received via SeaTalk.

- Press **disp** to cancel the alarm.

Man overboard (MOB)

If a man overboard (MOB) message is received from another instrument on the SeaTalk system, the text MOB is shown instead of the waypoint number for the XTE, DTW and BTW Data Pages.

If the autopilot is operating in Track mode, the Waypoint Advance alarm will sound to notify the change in waypoint.

Chapter 4: Customising the ST5000 Plus

The ST5000 Plus provides setup and configuration options that are used to adjust the settings for the ST5000 Plus itself, the compass, and the autopilot.

Note: *You should perform the post installation procedures described in Chapter 6 before adjusting any other calibration features.*

There are three setup levels:

- **User Setup**, which controls compass setup, rudder calibration and the ST5000 Plus display features
- **Intermediate Setup**, which displays version number information
- **Dealer Setup**, which controls the autopilot settings, and also the calibration lock which can be used to prevent accidental access to User and Intermediate Setup

The ST5000 Plus is calibrated at the factory to provide stable performance for most yachts. Although many of the setup and calibration features available in the ST5000 Plus can be fine tuned, it should not normally be necessary to adjust the Dealer Setup values once the initial installation and trials have been performed.

4.1 User setup

The flow chart on the following page shows the User Setup control procedure, and the setup screens with their default settings. Information on the functions of the different settings is given in the remainder of this section.

The following points should be considered:

- Make sure that the autopilot is in Standby mode before you access User Setup
- If the CAL LOCK screen is displayed instead of the initial page, you need to turn off the lock feature in Dealer Setup
- Setup options are always saved on exit

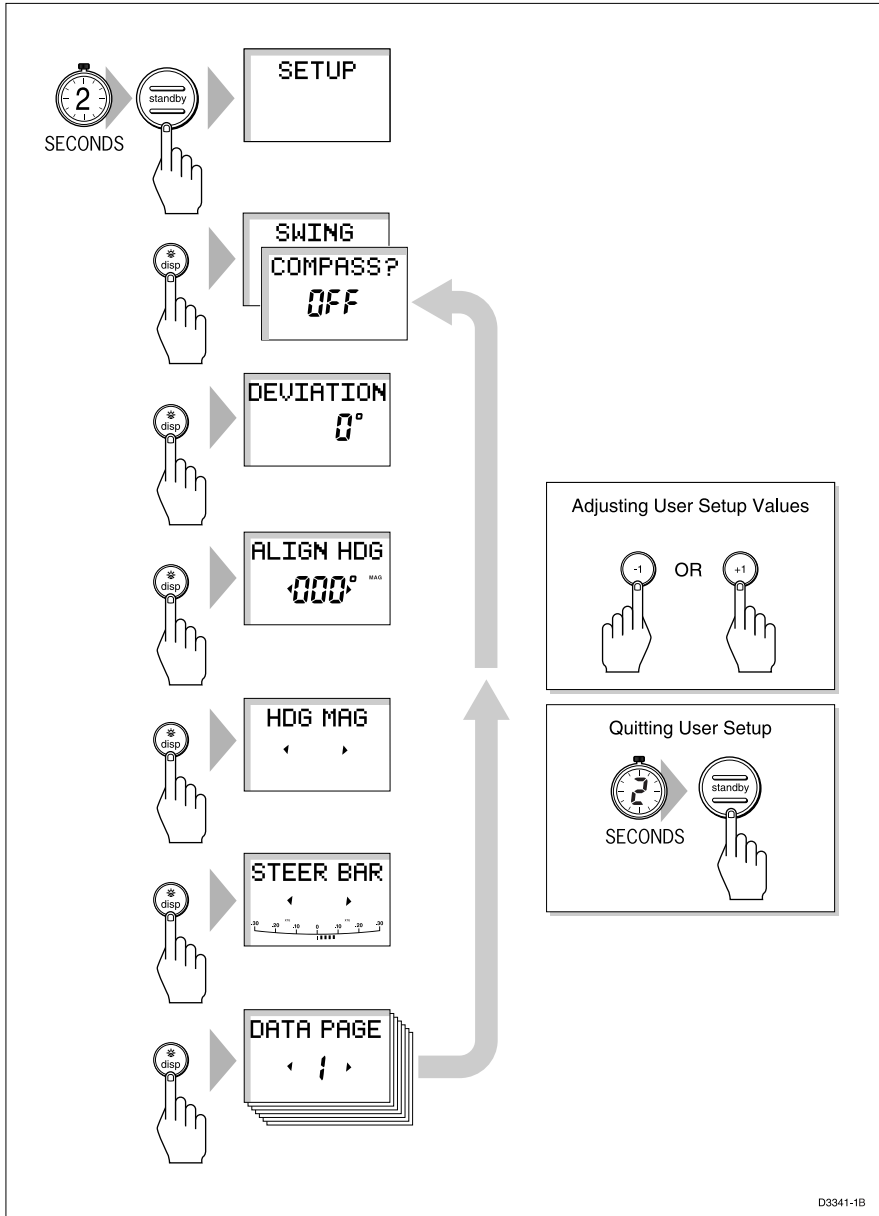

Compass deviation correction (SWING COMPASS)

The compass deviation correction option allows you to correct the compass for deviating magnetic fields. The procedure must be performed as the first item in your initial sea trial, and is described in detail in *Chapter 6, Post Installation Procedures*.

Deviation display (DEVIATION)

The deviation screen shows the current deviation value, calculated from the correction procedure (Swing Compass). You cannot edit this value.

Heading alignment (ALIGN HDG)

The heading alignment screen is used to align the autopilot compass with the ship's compass.

- Steer your vessel onto a known heading.
- Adjust the displayed heading using the **-1**, **+1**, **-10** and **+10** keys.
- Check the autopilot display on various headings and adjust as necessary.

Heading mode (HDG MAG/TRUE)

Select either magnetic or true heading mode. When heading data is displayed in normal operation, the screen indicates whether true or magnetic mode has been selected.

Bar selection (RUDD BAR/STEER BAR/NO BAR)

Select the type of bar graph that is shown at the bottom of the displays. The options are as follows:

- **RUDD BAR:** This shows the rudder position, and is the default setting. Note that a rudder reference transducer is required for accurate rudder position information.
- **STEER BAR:** The bar graph is used as a direction-to-steer indicator, as follows:

Mode	Bar
Standby	Rudder bar for systems with a rudder reference transducer
Auto compass	Heading error bar
Track	XTE bar
Vane	Wind angle

Data pages (DATA PAGE)

The next 7 User Setup pages allow the settings for the Data Pages to be modified. These are the SeaTalk/NMEA data pages available during normal operation (see section 2.5).

Each setup page initially shows the title DATA PAGE. After 1 second, this changes to the title of the data currently set for that page.

The available pages are as follows:

Data	Displayed as
Speed Knots	SPEED KTS
Log	LOG XXXX.X
Trip	TRIP XXX.X
Average Speed, Knots	AV. SPD KTS
Wind Direction	E.g. WIND PORT
Wind Speed	WIND KTS
Depth Metres	DEPTH M
Depth Feet	DEPTH FT
Depth Fathoms	DEPTH FA
Heading	HEADING
Water Temperature, Degrees C	WATER °C
Water Temperature, Degrees F	WATER °F

Data	Displayed as
Course Over Ground	COG
Speed Over Ground, Knots	SOG KTS
Cross Track Error	XTE
Distance to Waypoint	DTW
Bearing to Waypoint	BTW
Rudder Gain	RUDD GAIN
Response	RESPONSE
Watch	WATCH
Universal Time Constant	UTC

There are 3 depth pages and 2 water temperature pages. Data is displayed in the units defined by the selected page.

The default settings are:

Data Page	Default Setting	New Setting
1	XTE Cross Track Error	
2	BTW Bearing to Waypoint	
3	DTW Distance to Waypoint	
4	NOT USED	
5	NOT USED	
6	NOT USED	
7	NOT USED	

- For each setup page, scroll forwards or backwards through the available data pages, using the **+1** or **-1** keys.

Note: *If you set a page to NOT USED, it is omitted from the display cycle during normal operation. For example, with the default page settings only three pages are displayed in the sequence.*

- Press **disp** to move on to the next Data Page selection screen, and repeat the selection procedure.

Note: *If a man overboard (MOB) message is received by the autopilot, the BTW and DTW pages will display the bearing and distance to the MOB location, so it is good practice to retain these pages for display.*

4.2 Dealer setup

Dealer Setup allows you to customise the autopilot to your boat. However, the factory default settings will provide safe performance for the initial sea trial, and fine tuning is not normally required.

The flow chart on the following page shows you how to enter Dealer Setup, scroll through the setup displays, adjust the values and exit.

The features that can be adjusted are listed in the table following the flowchart. If you change any of the settings you can record them in the *New Setting* column for future reference.

Information on the functions of the different settings is given in the remainder of this section. The following points should be noted:

- Make sure that the autopilot is in Standby mode before you access Dealer Setup
- Setup options are always saved on exit

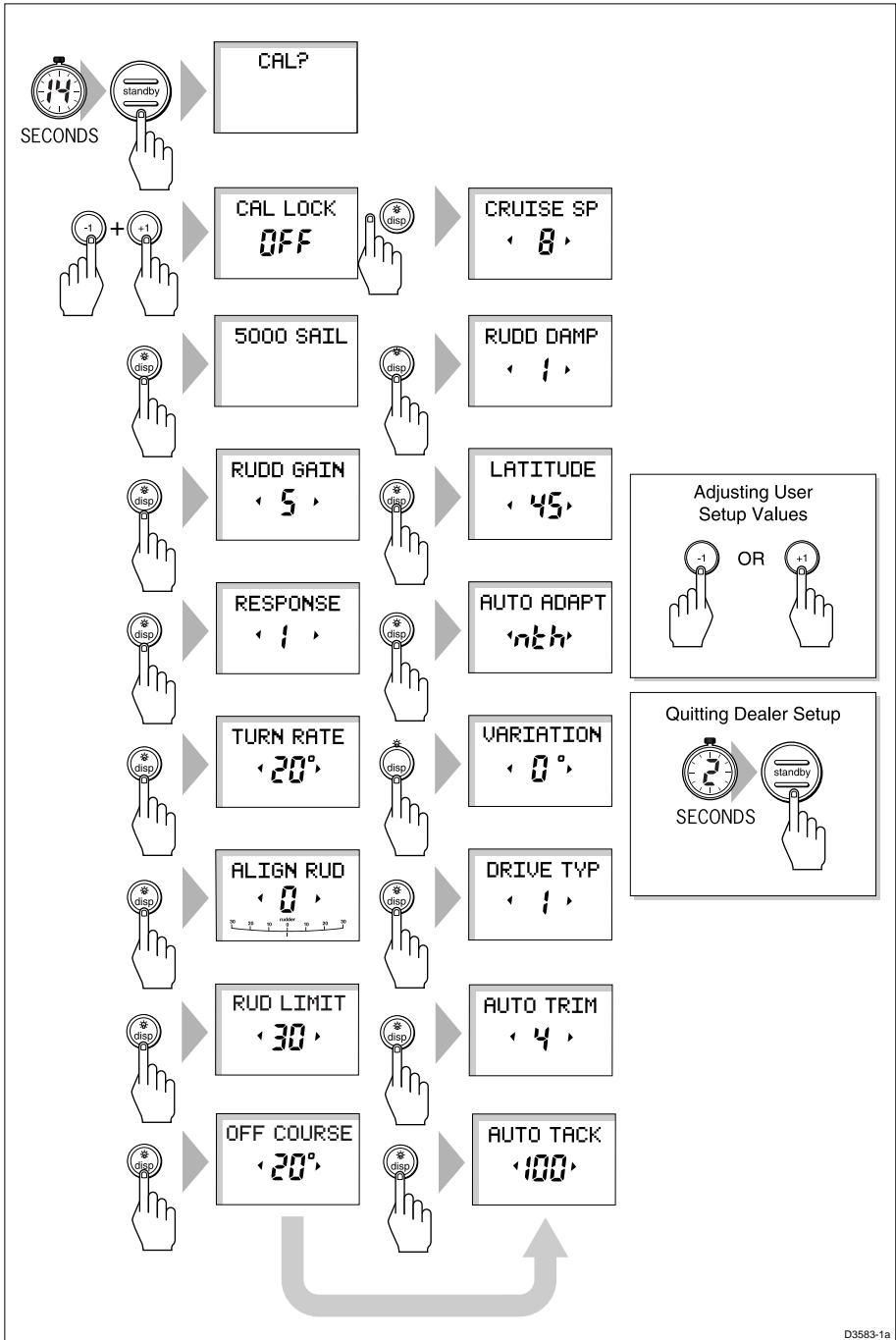

Feature	Options/ Range	Default Setting	New Setting
Calibration lock	ON or OFF	OFF	
Pilot type	5000 SAIL	5000 SAIL	
Rudder gain	1 to 9	5	
Response	1 (AutoSeastate) or 2 (no AutoSeastate)	1	
Turn rate limit	5 to 40	40	
Align Rudder	-7 to +7	0	
Rudder limit	15 to 40	30	
Off course alarm	15 to 40	20	
AutoTack angle	40 to 125	100	
AutoTrim	OFF, 1 to 4	3	
Drive type	1 (soft drive) or 2 (hard drive)	1	
Variation	-30 to +30	0	
AutoAdapt	N, S, OFF	OFF	
Latitude	0 to 80	0	
Rudder damping	1 to 9	1	
Cruise speed	4 to 60	6	

Calibration lock

Calibration lock controls whether User Setup and Intermediate Setup are available, and is intended for charter boat users.

Pilot type

The default setting of 5000 SAIL should be retained.

Rudder gain

This is the “power-on” rudder gain setting and should be adjusted to the setting which gives the best steering performance as described in *Chapter 6*.

Response

This is the power-on response setting. The response level can be changed during normal operation (see section 3.3) or via the Response Data Page, if this is set for display (see section 2.5).

Turn limit

This limits the rate of turn of your vessel when under autopilot control. The value must be within the range 5 to 20°. For sailboat applications it should be set to 20°.

Align rudder (Rudder Offset)

Set this option if your system includes a rudder reference unit.

1. Manually centre the helm. The reported rudder angle is indicated on the rudder bar graphic at the bottom of the screen.
2. Adjust the offset, using the **+1** and **-1** keys, until the rudder position is shown as central on the rudder bar. The offset must be within -7° to +7°.
3. If required, move the rudder reference unit and repeat this procedure.

Rudder limit

The rudder limit function enables you to set the limits of autopilot rudder control just inside the mechanical end stops, and thereby avoid putting the steering system under unnecessary load. The adjustment range is from 15° to 40° of rudder movement.

If your boat is fitted with a rudder reference transducer, set the autopilot rudder limit as follows:

1. Manually set the rudder to each end stop (port and starboard), and in each case use the rudder bar on the display, to determine the end-stop angle.

2. Access the rudder limit screen (RUD LIMIT).
3. Set the autopilot rudder limit so that it is 5° less than the smallest (port or starboard) mechanical end stop angle.

Off Course alarm

This feature controls the alarm that warns you if the autopilot is unable to maintain its set course. The alarm operates if the pilot strays off course by more than the alarm angle limit for more the 20 seconds. The value must be within 15° to 40° , and can be adjusted in 1° steps.

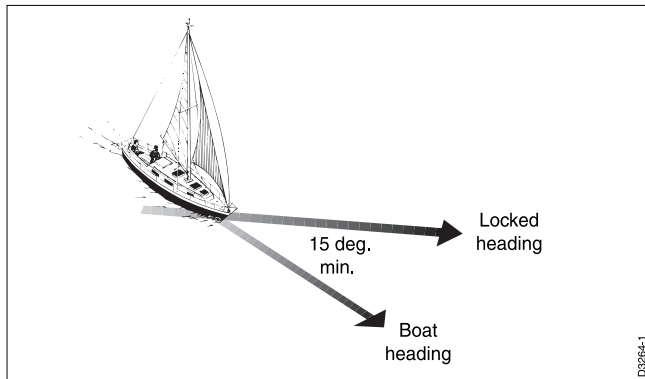

AutoTack angle

The AutoTack angle is the angle through which the vessel will turn when automatic tack is selected (see *Chapter 2*). The value must be within the range 40 to 125° , and can be adjusted in 1° steps.

AutoTrim

The AutoTrim level setting determines the rate at which the autopilot applies “standing helm” to correct for trim changes caused by varying wind loads on the sails or superstructure. The settings are:

Setting	Effect	Recommended for:
Off	No trim correction	
1	Slow trim correction	Heavy displacement vessels, with full keel or transom rudder.
2	Medium trim correction	Heavy displacement vessels.
3	Fast trim correction	Moderate to light displacement vessels.
4	Fast trim correction	Planing power vessels

The default settings should provide optimum performance with the ST5000 Plus autopilots. However, depending on the vessel's dynamic stability, an incorrect rate of trim application may result in poor course keeping due to autopilot instability. After gaining experience with the ST5000 Plus, you may wish to change the setting. The effect of the setting must be evaluated while under sail.

- Decrease the AutoTrim level if the autopilot gives unstable course keeping or excessive drive activity with a change in the heel angle.
- Increase the AutoTrim level if the autopilot reacts slowly to a heading change due to a change in the heel angle.

Drive type

Drive type controls the way which the autopilot drives the steering system. The default settings (soft drive) should be retained.

Variation

If required, set this to the level of magnetic variation present at your vessel's current position – indicated as East (E) or West (W). The variation setting is sent to other instruments on the SeaTalk system, and can be updated by other SeaTalk instruments.

AutoAdapt

The patented AutoAdapt feature allows the ST5000 Plus to compensate for heading errors at higher latitudes, which are caused by the increasing dip of the earth's magnetic field. The increased dip has the effect of amplifying rudder response on northerly headings in the northern hemisphere, and on southerly headings in the southern hemisphere.

Set AutoAdapt to **nth** in the northern hemisphere, or **Sth** in the southern hemisphere. You then need to enter your current latitude in the next setup screen, so that the ST5000 Plus can provide accurate course keeping by automatically adjusting the rudder gain depending on the heading.

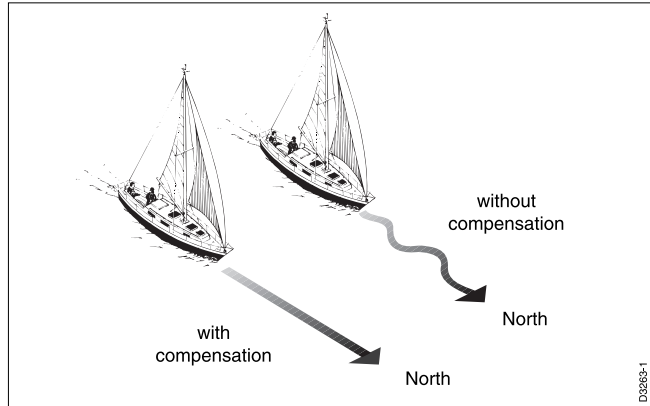

Latitude

This screen is only displayed if AutoAdapt is set to **nth** or **Sth**.

Use the **+1** and **-1** keys to set the value to your vessel's current latitude, to the nearest degree.

Note: If valid latitude data is available via SeaTalk or NMEA, it will be used instead of this calibration value.

Rudder damping

Set this option if your system includes a rudder reference unit and the drive "hunts" when trying to position the rudder. Test this when your vessel is moored dockside, by pressing **auto** and then **++10**. If the helm overshoots and has to drive back or starts to hunt back and forth, you need to increase the damping level.

Adjust the damping one level at a time, and always use the lowest acceptable value.

Cruise speed

If boat speed is not available via SeaTalk or NMEA, cruise speed should be set to the boat's normal cruising speed.

Chapter 5: Installation

We recommend that you get an experienced professional, who is familiar with your boat's primary steering system, to install your new autopilot.

5.1 Planning the installation

This chapter explains how to install and connect the following:

- Control head
- Fluxgate compass
- Rudder reference transducer
- Linear drive
- NMEA interface

Before starting the installation, decide how you will site the units and run the cables.

EMC installation guidelines

All Raymarine equipment and accessories are designed to the best industry standards for use in the leisure marine environment.

Their design and manufacture conforms to the appropriate Electromagnetic Compatibility (EMC) standards, but correct installation is required to ensure that performance is not compromised. Although every effort has been taken to ensure that they will perform under all conditions, it is important to understand what factors could affect the operation of the product.

To minimise the risk of operating problems:

- All Raymarine equipment and cables connected to it should be:
 - At least 1 m (3 ft) from any equipment transmitting or cables carrying radio signals e.g. VHF radios, cables and antennas. In the case of SSB radios, the distance should be increased to 2 m (7 ft).
 - More than 2 m (7 ft). from the path of a radar beam. A radar beam can normally be assumed to spread 20 degrees above and below the radiating element.
- The equipment should be supplied from a different battery than the one used for engine start. Voltage drops below 10 V in the power supply to our products can cause the equipment to reset. This will not damage the equipment, but will cause the loss of some information and can change the operating mode.

- Raymarine specified cables should be used at all times. Cutting and rejoining these cables can compromise EMC performance and so must be avoided unless doing so is detailed in the installation manual.
- If a suppression ferrite is attached to a cable, this ferrite should not be removed. If the ferrite has to be removed during installation it must be reassembled in the same position.

Suppression Ferrites

The following illustration shows the typical range of suppression ferrites fitted to Raymarine equipment. Always use the ferrites specified by Raymarine.

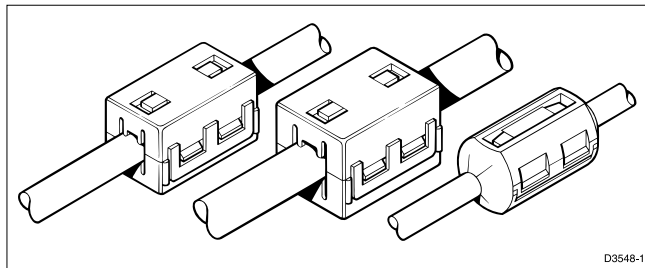

Connections to other equipment

If your Raymarine equipment is going to be connected to other equipment using a cable not supplied by Raymarine, a suppression ferrite **MUST** always be fitted to the cable close to the Raymarine unit.

Cabling

- Avoid running cables through bilges where possible
- Secure coiled lengths at regular intervals
- Avoid running cables close to fluorescent lights, engines, radio transmitting equipment etc

5.2 Control head

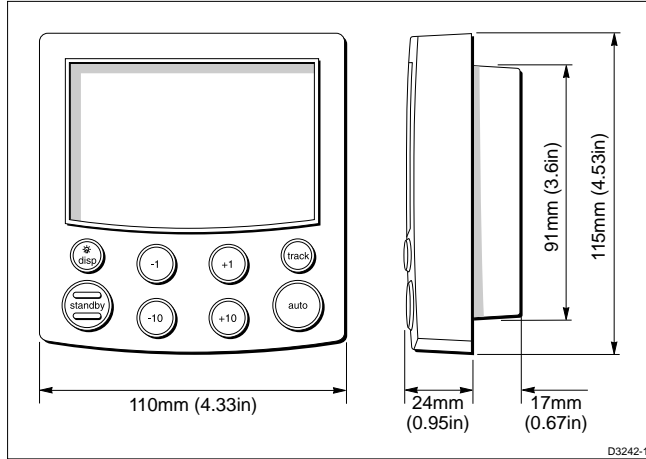

Siting

The control head is completely waterproof and should be sited where it is:

- Within easy reach of the steering position
- Protected from physical damage
- At least 230 mm (9 in) from any compass
- At least 1 m (3 ft) from any radio/radar receiving/transmitting equipment
- Mounted with sufficient space behind the bulkhead to install the cables

Note: *The back cover is designed to breath through the cable boss to prevent moisture accumulation. This must be protected from the weather by following the mounting procedure.*

Mounting procedure

Control heads are available in surface mount and flush mount styles. Use the appropriate procedure to mount your instrument, but in each case, ensure that:

- The selected location is clean, smooth and flat.
- There is sufficient space behind the selected location to accommodate the rear of the control head and connectors.

Note: *Adjacent control heads, or instruments, must have a 6 mm (1/4 in) gap between them to allow sun covers to be fitted.*

Surface mounting

To fit a surface mount control head:

1. Apply the surface mount template (supplied near the rear of this handbook) to the selected bulkhead.
2. Mark the centres of the two fixing holes and the cable boss.

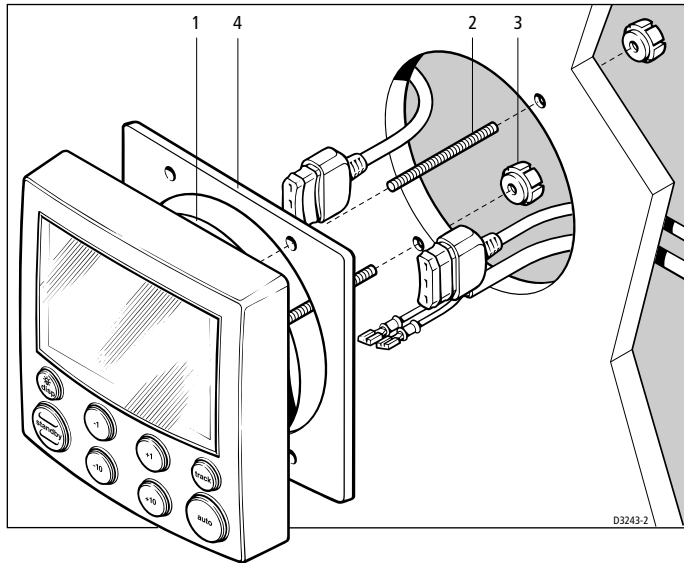

3. Drill two 4 mm (5/32 in) diameter holes for the fixing studs.
4. Use a 90 mm (3.5 in) diameter cutter to drill the hole for the cable boss (1).
5. Peel off the protective sheet from the self-adhesive gasket (4) then stick the gasket into position on the rear of the control head bezel.
6. Screw the fixing studs (2) into the display head.
7. Pass the cables (SeaTalk, power, compass etc.) through the bulkhead and connect them to the appropriate terminals (see relevant subsection for connection details).
8. Assemble the control head to the bulkhead.
9. Secure the control head with the thumb nuts (3) provided. Tighten the thumb nuts **BY HAND**. Do **NOT** use a wrench.

Flush mounting

To fit a flush mount control head:

1. Ensure that the panel on which you intend to mount the control head is between 3 mm and 20 mm thickness.
2. Apply the flush mount template (supplied near the rear of this handbook) to the selected location and mark out the aperture into which the control head will sit.
3. Cut out the aperture (3) for the control head and remove the template.
4. Peel off the protective sheet from the self-adhesive gasket (4) then stick the gasket into position on the rear of the control head bezel.

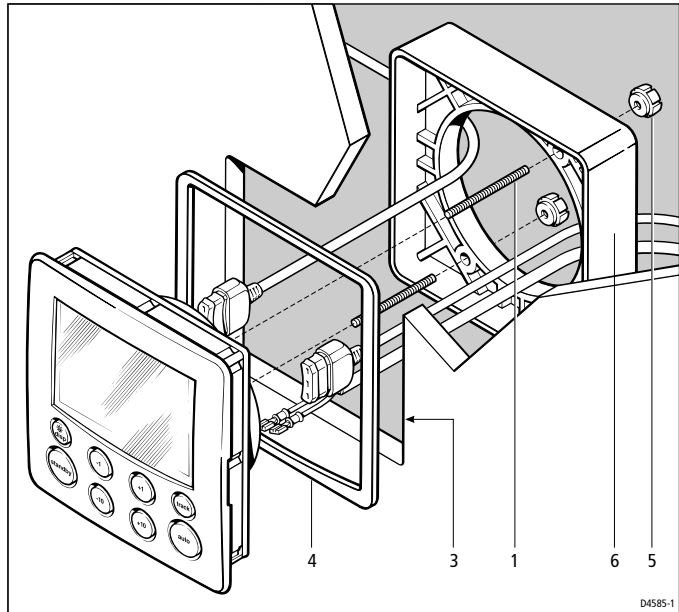

5. Screw the two fixing studs (1) into the threaded sockets on the rear of the control head.
6. Pass the cables (SeaTalk, power, compass etc.) through the bulkhead and connect them to the appropriate terminals (see relevant subsection for connection details).
7. Mount the assembled control head, studs, and gasket into the panel.
8. Locate the bracket (6) onto the fixing studs and secure the assembly to the panel with the thumb-nuts (5). Tighten the thumb nuts **BY HAND**. Do **NOT** use a wrench.

Cable connectors

- All connections, except for the SeaTalk cables, are made via spade connectors.
- When fitting the spade connectors, make sure the connector fits securely over the blade and not between the connector and its plastic insulating boot – incorrect fitting will give intermittent contact which will lead to faulty autopilot operation.

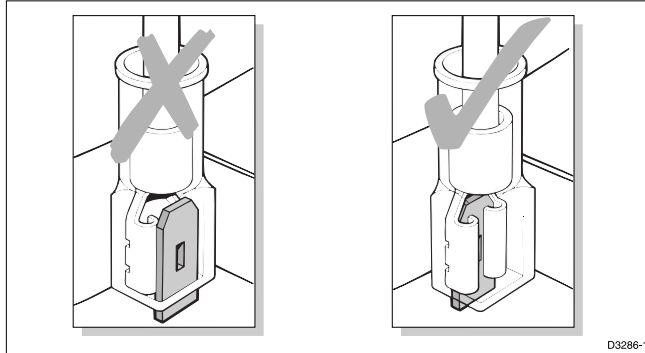

Power supply connection

- The control head requires its own dedicated power supply. It cannot source power from SeaTalk, and must supply the power to the rest of the SeaTalk system.
- The ST5000 Plus is supplied with a 2 m (6.5 ft) power lead terminated with 6 mm (1/4 in) spade connectors.
- A 20 A circuit breaker or fuse must be fitted to the +12 V supply.

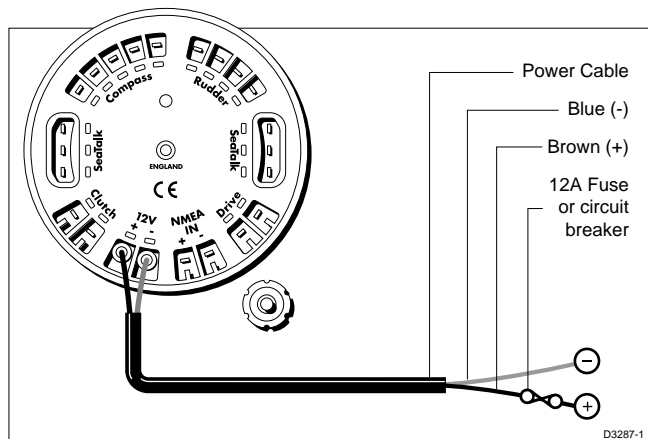

- If the supplied power lead is too short, the lead can be extended if required. The table shows the minimum acceptable cable sizes:

Cable Length	Copper Area	AWG
Up to 2.5 m (8 ft)	2.5 mm ²	14
Up to 4.0 m (13 ft)	4.0 mm ²	12

Note: *Correct cable size is critical for correct autopilot operation. If the cable is too small, a voltage drop will occur between the supply and the control head. This will reduce the power to the drive, causing slower response to course changes and corrections.*

Connection to the SeaTalk bus

SeaTalk cables are not supplied with the equipment, as different installations have different cabling requirements.

SeaTalk Cables

The following table lists the standard SeaTalk cables available from your Raymarine dealer:

Part No:	Cable Type	Length
D187	Flat to a male round connector	0.15 m (6 in) long
D188	Flat to a female round connector	0.3 m (12 in) long
D284	Flat moulded plugs at both ends	1 m (3 ft 3 in) long
D285	Flat moulded plugs at both ends	3 m (9 ft 9 in) long
D286	Flat moulded plugs at both ends	6 m (19 ft 6 in) long
D287	Flat moulded plugs at both ends	9 m (29 ft 3 in) long

Cable Types

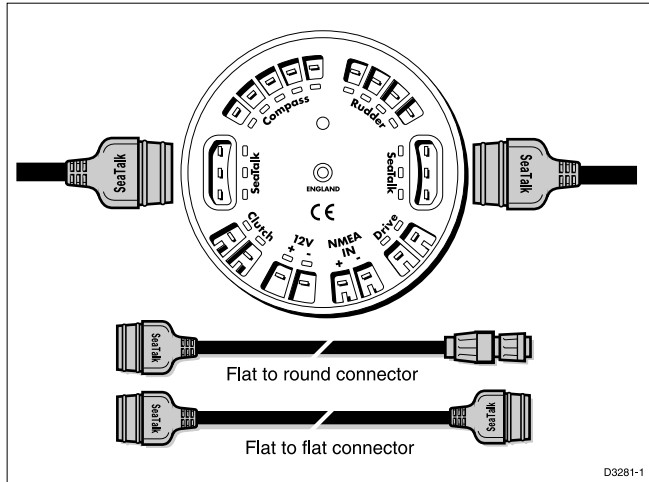

D3281-1

Typical SeaTalk Cabling

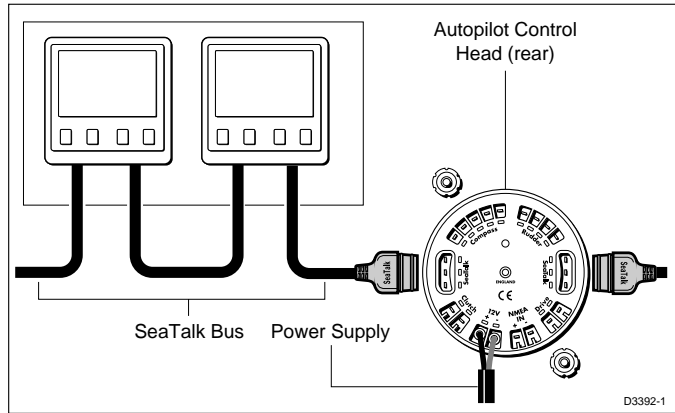

D3392-1

5.3 Fluxgate compass

Correct positioning of the fluxgate is crucial if ultimate autopilot performance is to be achieved.

The fluxgate should, to minimise gimbals disturbance, be positioned as near as possible to the pitch and roll centre of the vessel.

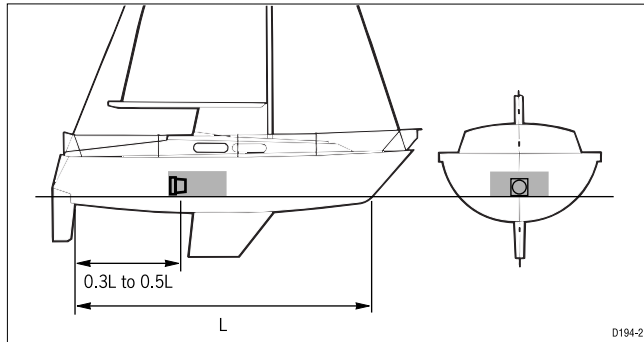

- To avoid deviation of both compasses, the fluxgate compass should be installed at least 0.8 m (2.5 ft) away from the steering compass.
- The fluxgate compass must be positioned as far away as possible from large iron masses, such as the engine and other magnetic devices, which may cause deviation and reduce the sensitivity of the sensor.
- If you have any doubts about the magnetic suitability of the chosen site, the position may be surveyed using a simple hand bearing compass. The hand bearing compass should be fixed in the chosen position and the vessel swung through 360°.
- Differences between the hand bearing compass and the main steering compass should, ideally, not exceed 20° on any heading.

Mounting location for steel-hulled vessels

If you have a steel-hulled vessel and mount the compass in the conventional location, you will obtain significant deviation due to the effects of steel on the Earth's magnetic field.

To minimise this effect, you should raise the compass transducer above the main deck or wheelhouse. However, the higher above the waterline you mount the transducer, the more the vessel's pitch and roll will affect the compass performance. Recommended mounting positions are shown in the following diagram.

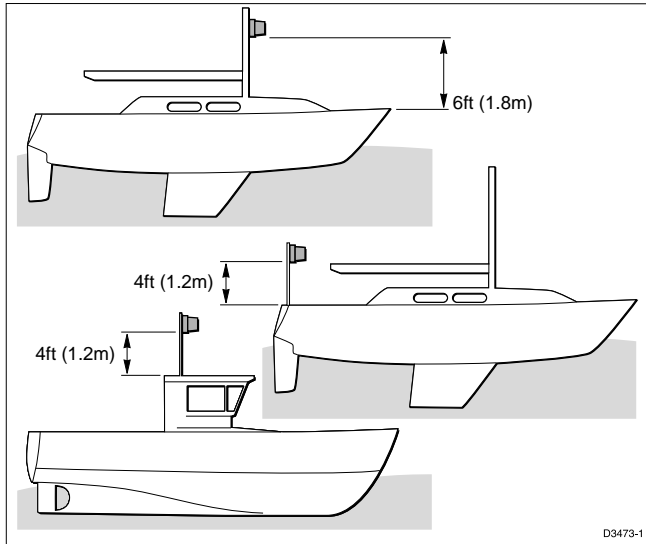

Installing the fluxgate compass

Attach the fluxgate compass to a bulkhead using the four self-tapping screws provided.

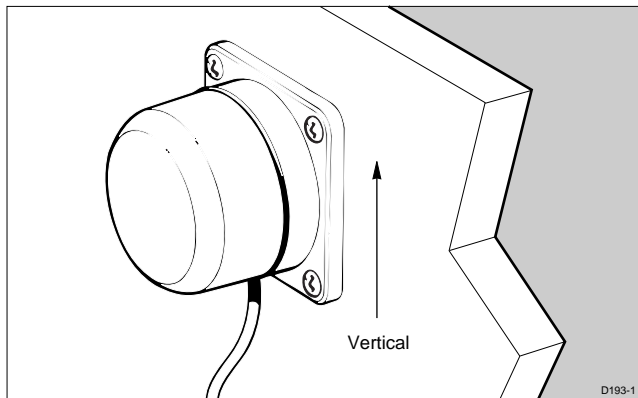

Note: A label is supplied to warn people that the compass is mounted behind or below the bulkhead. This label should be attached where it can be clearly seen.

Cabling

1. Route the fluxgate compass cable back to the control head.
2. Connect the five core cable (colour for colour) to the **Compass** terminals.

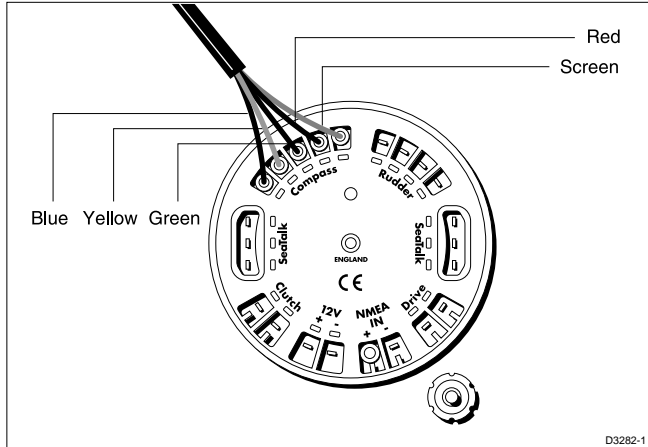

5.4 Rudder reference transducer

A rudder reference transducer is supplied with the ST5000 Plus SailPilot. This device provides the autopilot with accurate information on the position of the rudder.

Mounting position

- The rudder reference transducer should be attached to a suitable base adjacent to the rudder stock.

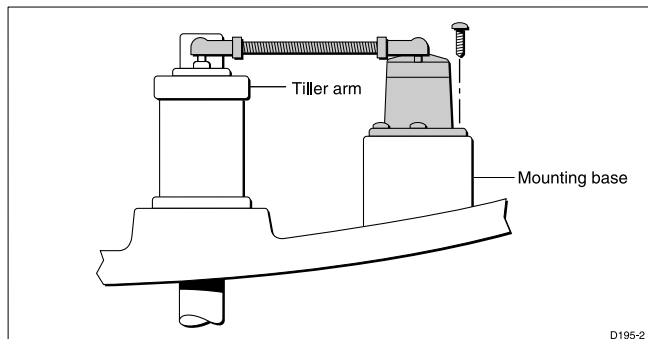

- The base height must maintain the correct vertical alignment of the transducer arm and tiller arm.
- If it is more convenient, the transducer may be mounted upside down (logo downwards).
- The transducer has a built in spring to remove any free play in the linkage to the tiller. This gives very precise rudder position.
- Transducer arm movement is limited to $\pm 60^\circ$.
- Care must be taken during installation to ensure the transducer arm is opposite the cable entry when the rudder is amidships. Failure to position the arm correctly could result in damage if the arm is driven onto its end stops by the steering system.

Control dimensions

- The dimensions must be within the specified limits.
- The tiller and transducer arms must be parallel to each other.
- With the rudder amidships, the transducer arm should be opposite the cable entry and at 90° to the connecting bar.
- Minor adjustments can be made by slackening off the retaining screws and rotating the transducer body.

Installing the rudder reference transducer

1. The tiller pin must be within the limits shown.

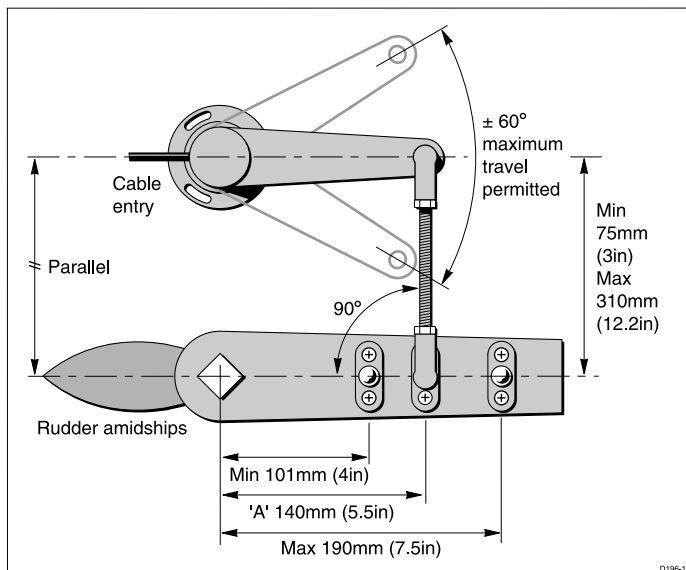

2. Dimension **A** should, ideally, be 140 mm (5.5 in) – changes within the limits shown will not degrade the autopilot performance but will slightly alter the scaling of the rudder angle display.
3. Use the self-tapping screws to secure the tiller pin to the tiller arm.
4. Cut the threaded rod to the required length.
5. Screw on the lock nuts and ball pin sockets.
6. Press the sockets onto the tiller pins.
7. Move the rudder from side to side to ensure the linkage is free from obstructions at all rudder angles.

Cabling

1. Run the rudder reference transducer cable back to the control head.
2. Connect the 4 wires (colour for colour) to the **Rudder** terminals.

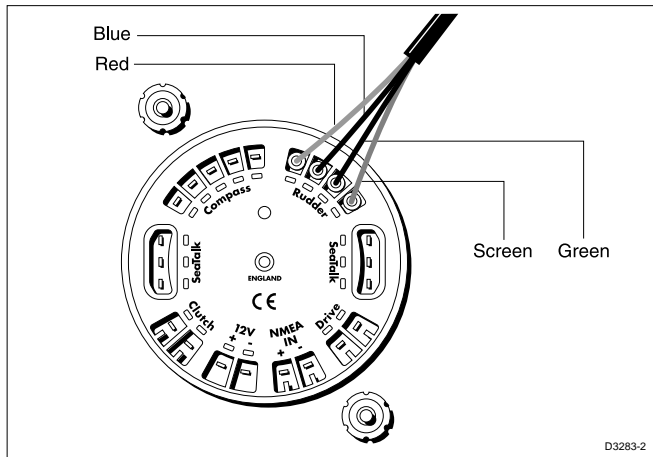

5.5 SailPilot linear drive installation

The SailPilot Linear Drive is connected directly to the rudder stock at the specified tiller arm radius.

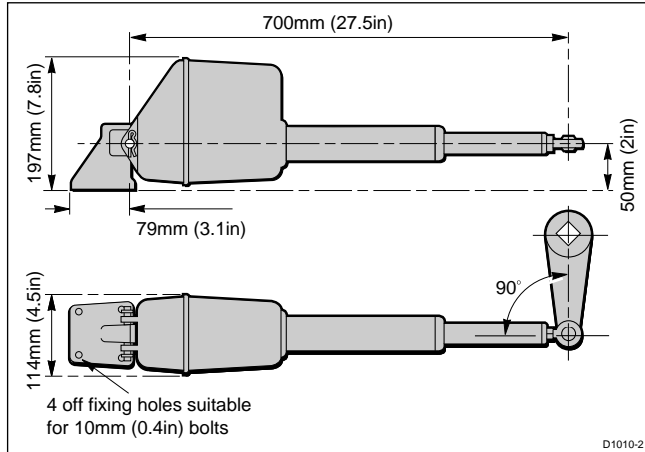

- The tiller arm radius for the SailPilot should be 250 mm (10 in)
- The drive unit should, ideally, be coupled to the rudder stock via an independent tiller arm (for example, Edson and Whitlock offer a standard fitting)
- It is possible to couple the drives pushrod to the same tiller arm or rudder quadrant used by the main steering linkage

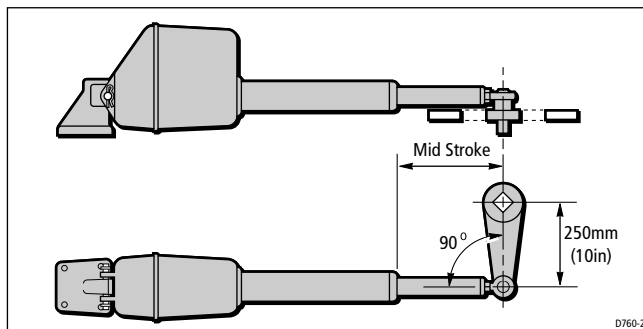

CAUTION:

The SailPilot drive unit can exert thrusts in excess of 1000 lb (454 kg). Therefore, if you have any doubts about the strength of the existing tiller arm or rudder quadrant, please consult the relevant steering gear manufacturer.

Mounting the drive unit

When siting the drive unit, please consider the following points:

- The bracket can be attached to any horizontal or vertical surface
- The drive unit can, if required, be installed upside down
- The ball end fitting allows up to 5° of misalignment between the pushrod and the tiller arms plane of rotation
- Accurate angular alignment is **extremely important** and, therefore, under no circumstances **must** this limit be exceeded
- The drive unit **must** be at right angles to the tiller arm when the rudder is amidships
- The drive unit should be clear of bilge water
- The mounting bracket should be bolted to a substantial frame member – always over-engineer to ensure reliability and maintenance of the correct alignment

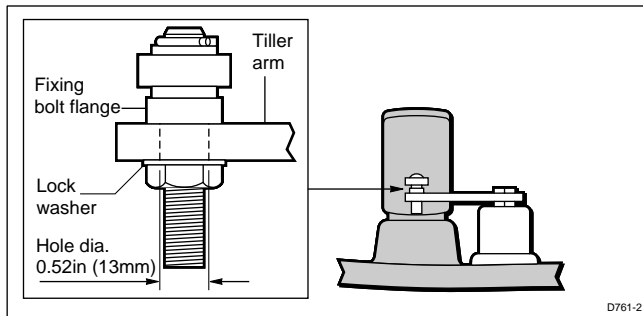

1. Using the adaptor pin supplied, make sure the pushrod ball is attached to the tiller arm with its flange positioned between the ball end and the tiller arm.
2. Make sure that the supplied lock washer is used and the nut is tightened fully.
3. Attach the mounting bracket using four stainless steel 3/8 in bolts and lock nuts/washers.
4. Having installed the drive unit, turn the steering wheel from hardover to hardover to check that:
 - No part of the drive units fouls on the yacht's structure
 - The mechanical limit stop on yacht's steering system is reached before the drive unit reaches its mechanical limit
 - Angular movement of the ball end fitting is less than 5°

Drive unit cabling

The SailPilot drive unit has electrical connections for both the motor and the clutch.

Use a suitable cable (refer to the following table) to connect the drive unit to the ST5000 Plus Control head (as shown).

Cable length	Copper area	AWG
Up to 2.5 m (8 ft)	2.5 mm ²	14
Up to 4 m (13 ft)	4.0 mm ²	12
Up to 6 m (19.5 ft)	6.0 mm ²	10
Up to 10 m (32 ft)	10 mm ²	8
Up to 16 m (32 ft)	16 mm ²	6

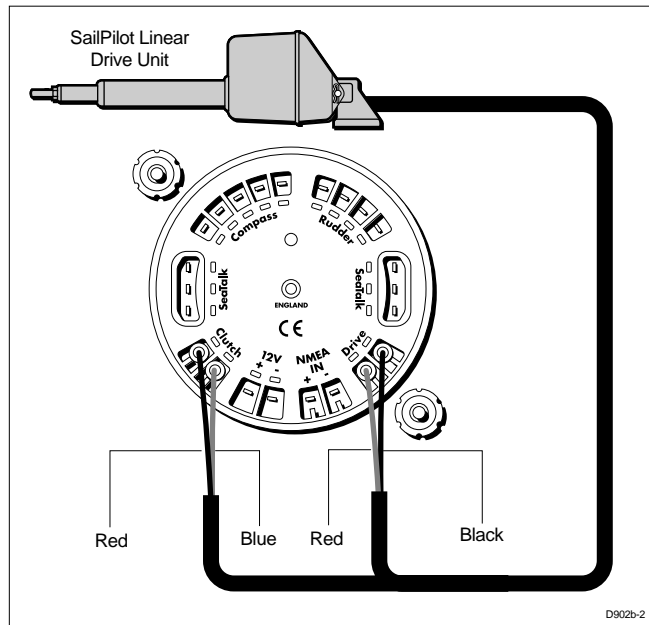

5.6 NMEA interface

ST5000 Plus will accept navigation data in the NMEA format for use in Track Control and Windvane modes. The required data formats are shown in the table at the end of this section.

Cabling

The NMEA data port is on the rear of the ST5000 Plus and should be connected to a Position Transducer or Wind Instrument.

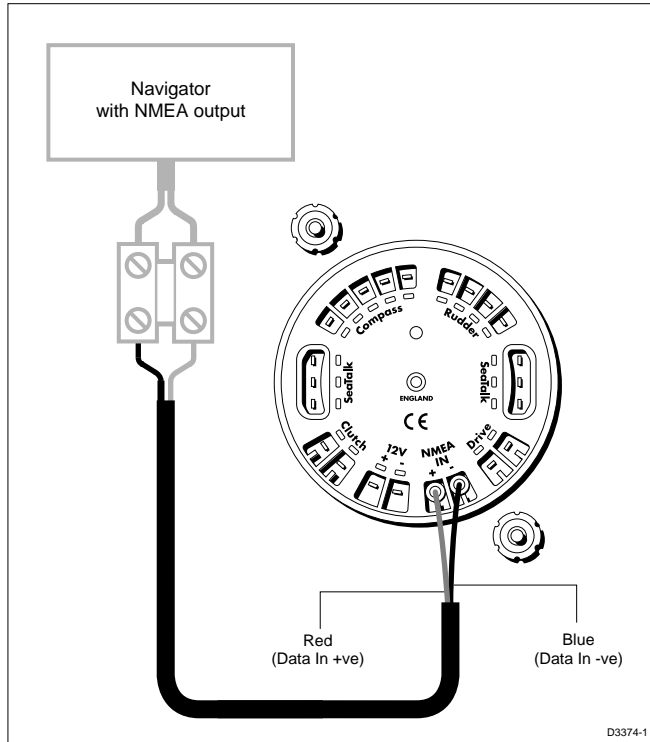

NMEA data transmission to other equipment

If you wish to transmit NMEA information to other equipment a SeaTalk Interface (Z290) should be installed.

Data formats

The following NMEA 0183 wind and navigation data can be decoded by ST5000 Plus.

Data	NMEA 0183
Course Over Ground	VTG, RMC, RMA
Speed Over Ground	VTG, RMC, RMA
Cross Track Error	APB, APA, RMB, XTE
Bearing to Waypoint	APB, BWR, BWC, RMB
Distance to Waypoint	BWR, BWC, RMB
Waypoint Number	APB, APA, BWR, BWC, RMB
Apparent Wind Speed	VWR, MWV
Apparent Wind Angle	VWR, MWV
Speed Through Water	VHW
Depth	DBT
Water Temperature	MTW

Note: *The autopilot only decodes the last four characters of waypoint names. Therefore, if long waypoint names are used, the last four characters must be unique to enable the waypoint advance function to work.*

Transmission of NMEA data on SeaTalk

If any of the above NMEA data is received and the equivalent data is not present on SeaTalk, the autopilot will transmit the data onto SeaTalk to make it available to other SeaTalk compatible instruments.

Depth is transmitted in the units defined by the first page in the data page rollover. Water temperature is always transmitted in °C.

Chapter 6: Post Installation Procedures

Once you have installed the system, you need to confirm that the system is wired correctly and is also set up to suit your type of boat.

This chapter provides instructions for the following procedures:

- **Functional test**, consisting of a few simple tests to confirm that the system is wired correctly
- **Dockside procedure**, necessary if a rudder reference transducer is fitted, to ensure that the rudder reference transducer is correctly aligned with the rudder.
- **Initial sea trial**, to swing the compass and align the heading, check the autopilot's operation and check the rudder gain

Further customisation can be performed after the sea trial, as described in *Chapter 4*.

6.1 Functional test

Switch on

Having installed your ST5000 Plus autopilot, switch on the main power breaker. If the control head is active and the system operating, the following will occur:

- The control head beeps and displays the pilot type (5000 SAIL).
- After the pilot type has been displayed for 2 seconds, the Standby mode screen should be displayed.

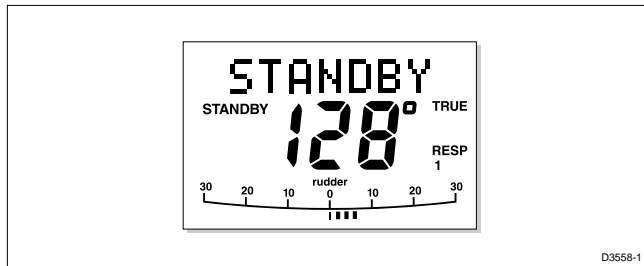

This shows that the control head is active.

- If the head does not beep, check the fuse/circuit breaker.
- If the SEATALK FAIL alarm is displayed, check the SeaTalk connections.

Operating sense

The operating sense defines the direction the helm will be applied when a course change key is pressed or the vessel goes off course. Check the operating sense as follows:

1. Press **auto**.
2. Press the **+10** key. The helm should move to produce a turn to starboard.

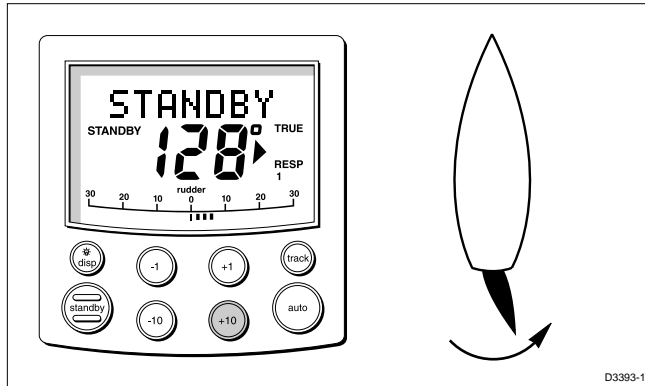

3. If the helm produces a turn to port, reverse the drive connections on the back of the control head.

Note: *If the helm overshoots and has to drive back or starts to hunt back and forth, you need to increase the Rudder Damping option in Dealer Setup (see Chapter 4).*

Navigation interface (GPS, Decca, Loran)

If the ST5000 Plus is interfaced to a navigator, via its NMEA data port, the interface can be checked by displaying the default Data Pages. These are XTE, BTW and DTW.

Press **disp** to display the first page, and check that the expected data is displayed. Press **disp** again to check each successive page.

If dashes are displayed instead of data values, the cause could be one or more of the following:

- A cabling error. Check for an open circuit, short circuit or reversed wires.
- The navigator is not configured to transmit the required data format.

- The signals being received by the navigator are too weak for reliable navigation. Refer to the navigator handbook for further action.

Wind transducer interface

If the ST5000 Plus is connected to a wind instrument via its NMEA data port or SeaTalk, then the link between the two instruments should be checked as follows:

Press **standby** and **auto** together.

The ST5000 Plus should display the Vane mode screen, with the locked wind angle and locked heading as shown.

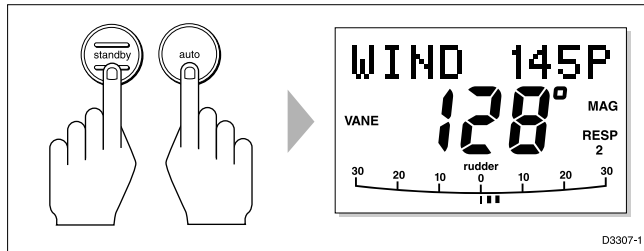

Alternatively, if the wind data is not received, the ST5000 Plus will display a NO DATA error message.

SeaTalk interface

If the ST5000 Plus has been linked to other SeaTalk instruments via SeaTalk, the link can be checked as follows:

1. Press **standby**.
2. Select display illumination level 3 on any other SeaTalk instrument or autopilot control unit.

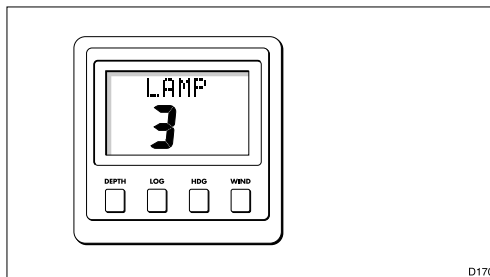

The ST5000 Plus should immediately respond by switching on its display illumination.

If the illumination does not switch on then a cabling fault exists in the SeaTalk cabling between the ST5000 Plus control head and the instruments/control unit.

6.2 Dockside procedure

The dockside procedure is only required if a rudder reference transducer is fitted, and ensures that the rudder reference transducer is correctly aligned with the rudder.

To carry out the procedure:

1. Move the helm to its centre position, using the **-1**, **+1**, **-10** and **+10** keys.
2. Check the rudder bar display. The rudder angle should be within $\pm 7^\circ$ of centre.
3. To improve the alignment, slacken the rudder reference mounting bolts and rotate the base until the reported rudder angle is as close to zero as possible. Then tighten the bolts again.
4. Fine adjustment, to align the display and helm accurately, is achieved using the *Align rudder* option in *Dealer Setup* (see *Chapter 4*). However, this cannot be used to correct an offset of more than $\pm 7^\circ$.
5. Carry out the *Rudder limit* procedure in *Dealer Setup* (see *Chapter 4*).

6.3 Initial sea trial

EMC conformance

- Always check the installation before going to sea to make sure that it is not affected by radio transmissions, engine starting etc.
- In some installations, it may not be possible to prevent the equipment from being affected by external influences. In general this will not damage the equipment but can lead to it resetting, or momentarily may result in faulty operation.

Overview

Having checked that the system is functioning correctly, a short sea trial is now required to complete the setup. It involves the following procedures:

- Automatic compass deviation correction
- Heading alignment adjustment
- Autopilot operation check
- Rudder gain adjustment

Note: *The ST5000 Plus has a built-in calibration capability which enables it to be fine tuned to suit the individual vessel, its steering system and dynamic steering characteristics. As supplied from the factory the unit is calibrated to provide safe stable autopilot control for the majority of vessels.*

The initial sea trial should be performed in the following circumstances:

- After all the installation, functional test and dockside procedures have been completed successfully
- Before any other changes have been made to the default calibration settings: check and, if necessary, reset the values to the recommended levels, as described in *Chapter 4*
- In conditions of light wind and calm water, so that autopilot performance can be assessed without the influence of strong winds or large waves
- In waters clear of any obstructions

Note: *At any time during the sea trial you can press **standby** to return to hand steering.*

Automatic compass deviation correction

The ST5000 Plus will correct the fluxgate compass for most deviating magnetic fields. Compass errors due to deviating magnetic fields can be up to 15°, depending on your vessel type. The correction procedure reduces these to a few degrees, so it is essential to perform the procedure as the first item in your initial sea trial.

CAUTION:

Failure to carry out the deviation correction may result in impaired autopilot performance on some compass headings.

To allow the system to determine the deviation and calculate any correction required, you must turn your vessel in slow circles. This procedure must be carried out in calm conditions and preferably in flat water.

To perform the deviation correction:

1. Make sure that the autopilot is in Standby mode.
2. Press and hold the **standby** key for 2 seconds to display the User Setup entry page.

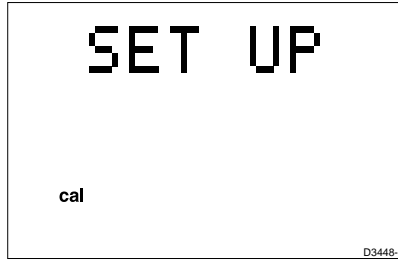

If CAL LOCK is displayed, you need to turn off the lock feature contained in Dealer Setup (see *Chapter 4*).

3. Press the **disp** key to move on to the Swing Compass page.

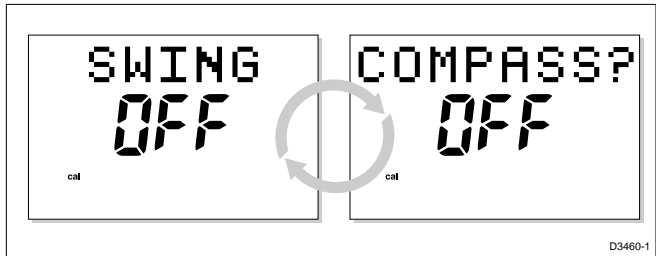

4. Press the **+1** or **-1** key to change the setting from OFF to YES. The Turn Boat page is then displayed.

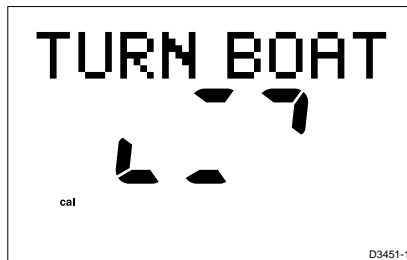

5. Keeping the boat speed below 2 knots, turn your vessel in slow circles. It should take at least 3 minutes to complete 360°.

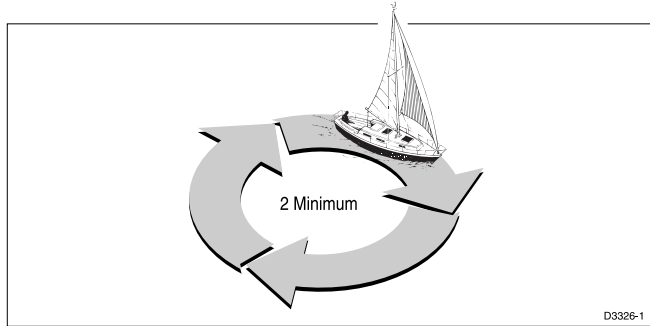

What if I turn the boat too quickly?

If you turn the boat too quickly for the compass to be corrected correctly, the text **TOO FAST** will be displayed. Apply less helm to turn in a larger circle.

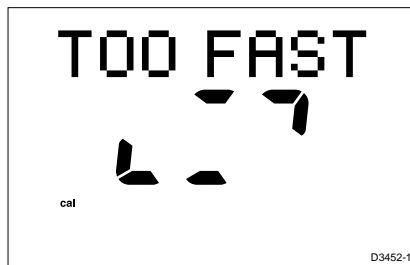

Can I cancel the process?

You can abort the correction process by pressing the **disp** key to move on to the **DEVIATION** screen.

If you wish to attempt deviation correction again, you can step back to the **Swing Compass** page or keep pressing **disp** to cycle through the calibration options until the page is displayed again. (To step back to the previous screen, press and hold the **disp** key for one second. You can only do this within two seconds of advancing to the current screen.) Repeat the procedure from step 4.

6. Keep turning your boat until the unit beeps and the **DEVIATION** screen is displayed.



This shows the maximum deviation detected, and indicates that compass correction has been completed successfully.

Note: *If the deviation value exceeds 15° or a deviation value is not displayed at all, you should consider moving the fluxgate compass to a better location.*

7. Press the **disp** key to move on to the Heading Alignment page.



8. Use the **+1** and **+1**, keys, or the **+10** and **-10** keys, to increase or decrease the displayed heading, until it agrees with the ship's steering compass or a known transit bearing.

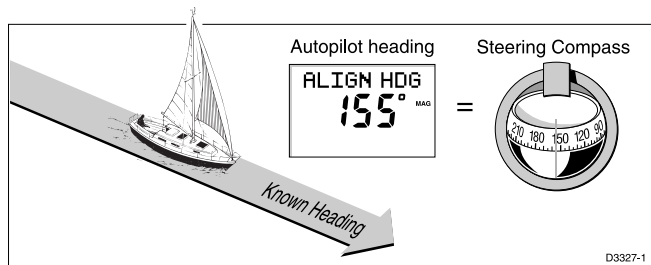

9. Press and hold **standby** for 2 seconds to exit calibration and save the new settings.

Note: *Setup options are always saved on exit.*

Further heading alignment adjustment

You should always check the compass alignment after swinging the compass. However, once the initial deviation correction procedure has been performed, you can make adjustments to the alignment as often as you wish, without swinging the compass again.

Although the compass deviation correction procedure removes most of the alignment error, you will probably be left with small errors (of the order of a few degrees) that will vary depending on the heading.

Ideally, you should check the heading reading against a number of known headings, plot a deviation curve, and determine the heading alignment value that will give the lowest **average** alignment error. This value can then be entered on the Heading Alignment screen, as described above.

If the average heading error is more than 5° , you should perform the compass deviation correction procedure again, circling slower and in more favourable conditions.

Checking autopilot operation

Having calibrated the compass the following procedure is recommended to familiarise yourself with autopilot operation:

1. Steer onto a compass heading and hold the course steady.
2. Press **auto** to lock onto the current heading. A constant heading should be achieved in calm sea conditions.
3. Use the **-1**, **+1**, **-10** and **+10** keys to alter course to port or starboard in multiples of 1° and 10° .
4. Press **standby** and disengage the autopilot to return to hand steering.

Checking the rudder gain

The factory set rudder gain level will provide stable control for initial sea trials. However, vessels can vary widely in their response to the helm, and further adjustment to the rudder gain may improve the autopilot's steering characteristics.

The following test will determine whether the rudder gain is set too high or too low.

1. In clear water and with the autopilot in Auto, alter course to starboard by 40° by pressing the **+10** key four times.
 - At cruising speeds, course changes of 40° should result in crisp turns followed by an overshoot of no more than 5°. If this occurs the rudder gain is adjusted correctly.
 - An excessively high rudder setting results in oversteer. This is recognised by a distinct overshoot of more than 5° (A). This condition can be corrected by reducing the rudder gain setting.
 - Similarly, an insufficient rudder control setting will result in understeer which gives sluggish steering performance (B). If the vessel takes a long time to make the turn and there is no overshoot then the rudder setting is too low.

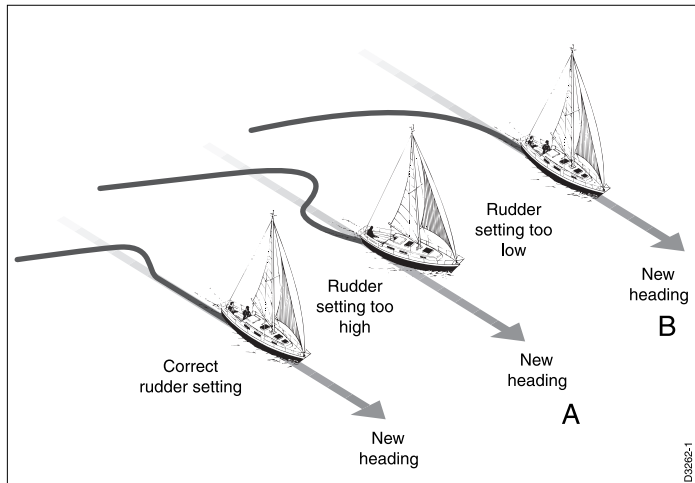

These actions are most easily recognised in calm sea conditions where wave action does not mask basic steering performance.

2. To make a temporary adjustment to the rudder gain, press the **-1** and **+1** keys together for 1 second to display the Rudder Gain screen, then press **-1** or **+1** to change the level. Wait for 5 seconds, or press **disp**, to return to the previous display.
3. Repeat the test until a crisp course change with no more 5° of overshoot is achieved.

The rudder control setting should be set to the lowest setting consistent with accurate course keeping. This will minimise helm movements and hence reduce power consumption and wear and tear.

4. Once you have determined the correct setting, change the default Rudder Gain setting in Dealer Setup, as described in *Chapter 4, Customising the ST5000 Plus*.

Chapter 7: Maintenance

General

- In certain conditions, condensation may appear on the LCD window. This will not harm the unit, and can be cleared by switching on the illumination for a while.
- **Never** use chemical or abrasive materials to clean your autopilot. If the pilot is dirty, wipe it with a clean, damp cloth.
- Periodically check the cabling for chafing or damage to the outer casing – replace any damaged cables.

Servicing and Safety

- Raymarine equipment should be serviced only by authorised Raymarine service engineers. They will ensure that service procedures and replacement parts used will not affect performance. There are no user serviceable parts in any Raymarine product.
- Some products generate high voltages, and so never handle the cables/connectors when power is being supplied to the equipment.
- Always report any EMC related problem to your nearest Raymarine dealer. We will use any such information to improve our quality standards.

Advice

Should any difficulties arise with this product, please contact the Raymarine Product Support department in the UK, or your own national distributor who will be able to provide expert assistance.

The working parts of the drive system are sealed and lubricated for life during manufacture – servicing is not required.

Before you consider returning the autopilot, make sure that the power supply cable is sound and that all connections are tight and free from corrosion.

If the connections are secure, refer to *Chapter 8, Fault Finding* chapter of this handbook. If the fault cannot be traced or rectified, please contact your nearest Raymarine dealer or Service Centre.

Always quote the product serial number, which is printed on the rear cover of the autopilot, and the software version number, which is displayed when you enter Intermediate Setup (see *Chapter 4*).

Chapter 8: Fault Finding

All Raymarine products are subjected to a comprehensive test procedure prior to packing and shipping. In the unlikely event that a fault does occur with your autopilot, the following check list should help identify the problem and provide a cure.

The autopilot display is blank

- No power – check the fuse/circuit breaker.

The displayed compass heading does not agree with the ships compass

- The compass has not been corrected for deviation – carry out the deviation and alignment procedures.

Vessel turns slowly and takes a long time to come on to course

- Rudder gain too low.

Vessel overshoots when turning on to a new course

- Rudder gain too high.

The autopilot appears to be unstable in Track mode, or track-holding is slow

- If tide speed exceeds 35% of boat speed, and boat speed is not available via SeaTalk, change the Cruise Speed setting in Dealer Setup to the boat's cruising speed.

The autopilot appears to be unstable on Northerly headings in the Northern hemisphere and Southerly headings in the Southern hemisphere

- Northerly/Southerly heading correction not set up.

Display shows CAL LOCK when entering calibration

- Calibration locked out – calibration protection feature is turned on in Dealer Setup.

The autopilot will not “talk” to other SeaTalk instruments

- Cabling problem – make sure all the cables are connected properly.

Position information not received

- Navigator not transmitting the correct position data.

The autopilot will not auto advance to the next waypoint

- No bearing to waypoint information received from the navigator.

A series of rotating dashes are displayed on screen

- Compass deviation correction is running.

The display shows a series of stationary dashes

- Data is not being received – check the cabling.

The display shows “NO DATA”

- The signals received from the navigator are too weak – refer to the navigator handbook for further action.
- Wind trim data is not available – check the connection to the wind transducer.

Index

A

- Advice 71
- Alarms 24
- Apparent wind angle
 - Adjusting 20
 - Previous 21
- Auto mode 5
- AutoAdapt 39
- Automatic Deadband 23
- Automatic track acquisition 14
- AutoSeastate 23
- AutoTack 7
 - Default angle 38
 - Vane mode 22
- AutoTrim
 - Default setting 38

B

- Bar graph 4

C

- Cabling 71
- Calibration 29–40
- Calibration lock 36
- Changing course 6
- Compass alignment 66
- Compass deviation correction 31, 63
- Course changes 6
 - operating hints 9
- Cross track error (XTE) 16
- Cruise speed 40
- Customising the autopilot 29–40

D

- Data Pages 11
 - Setting up 32
- Deadband 23
- Dealer Setup 34–40
- Depth alarm 27
- Deviation display 31
- Disengaging the autopilot 5

Display layout 4
Dodging obstacles
 Auto mode 6
 Track mode 18
 Vane mode 21
Drive Stopped alarm 25
Drive type 39

E

Engaging the autopilot 5

F

Fault finding 73
Functional test 59–60

G

Graph use 31

H

Hand steering 5
Heading 7
Heading alignment 31
Heading alignment adjustment 67
Heading mode 31

I

Illumination 10
Installation 41–58
Interfaces 60

K

Key functions 3

L

Large Cross Track Error alarm 16
LAST HDG 7
LAST WND 21
Latitude 40
Lighting 10
Low Battery alarm 26

M

- Maintenance 71
- Man Overboard (MOB) 27
- Manual steering 5
- Manual track acquisition 15
- Minimum Deadband 23

N

- Navigation data displays 11
- Navigation interface (GPS, Decca, Loran) 60
- NEXT WPT 26
- No Data alarm 25

O

- Off Course alarm 8
 - Default angle 38
- Operating modes 1
- Operating sense 60

P

- Performance 23
- Pilot type 36
- Previous heading 7

R

- Response level 23
 - Default setting 37
- Rudder bar 31
- Rudder damping 40
- Rudder gain 24, 37, 67
- Rudder offset 37

S

- Sea trial 62
- SeaTalk data displays 11
- SeaTalk interface 61
- Servicing 71
- Setup 29–40
- Shallow alarm 27
- Standby mode 5
- Steering bar 31
- Swinging the compass 63

T

- Testing autopilot operation 67
- Testing the system 59–60
- Tidal stream compensation 16
- Track acquisition 13
- Track mode 13–14
- Turn limit 37

U

- User Setup 29

V

- Vane mode 19–20
- Variation 39

W

- Watch alarm 26
- Waypoint arrival and advance 17
- Wind Shift alarm 21
- Wind transducer interface 61
- WindTrim 19–20

Surface mount template

Drill 5mm (3/16in)



Machine hole
90mm (3.54in)
diameter

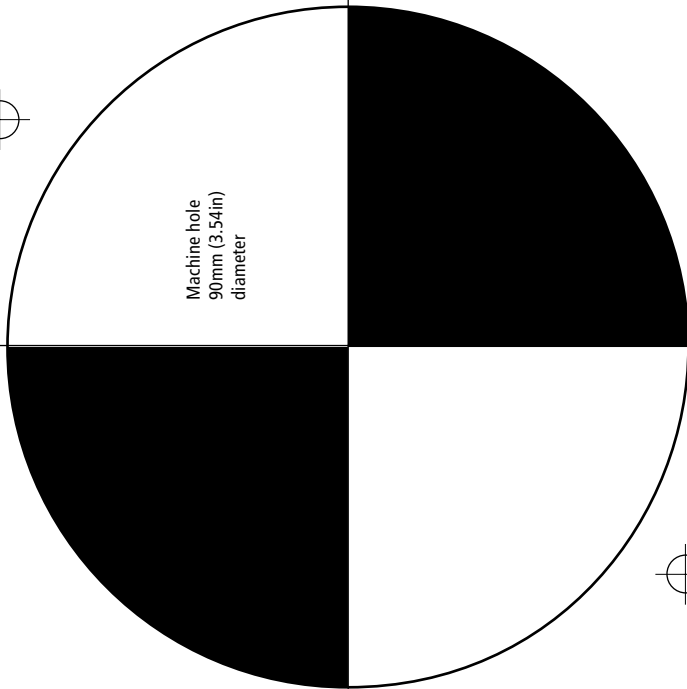

Drill 5mm (3/16in)





Flush Mount Template

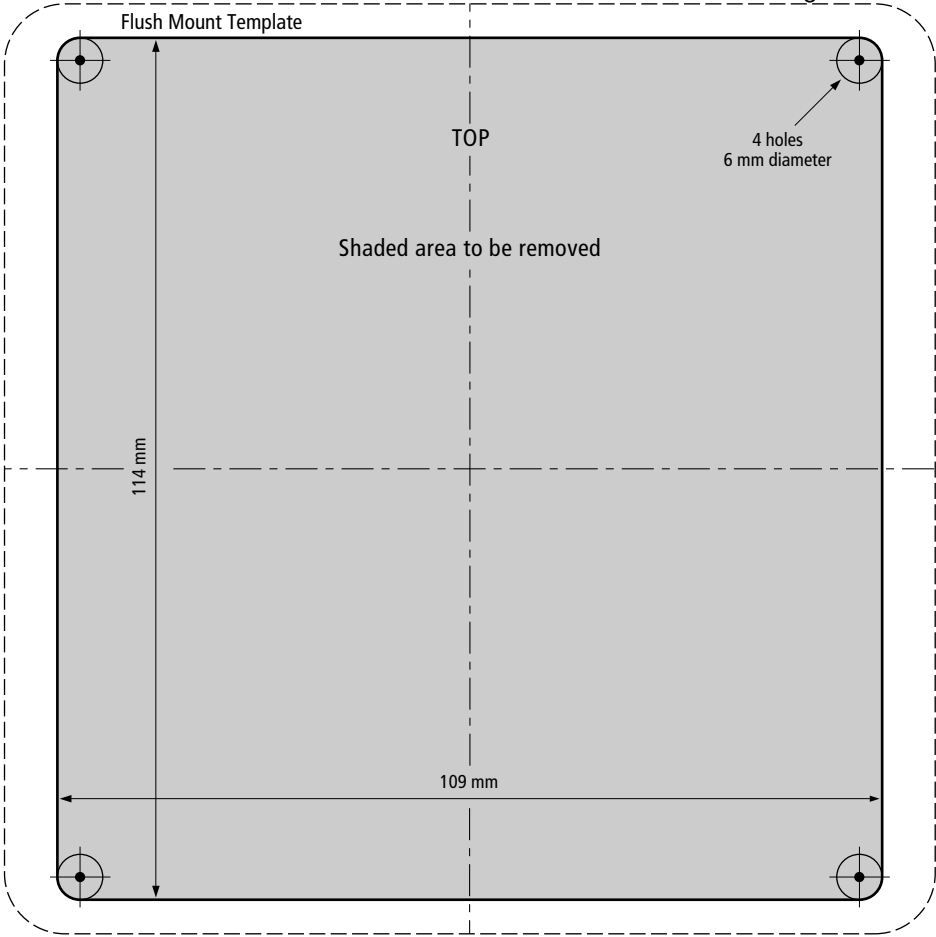

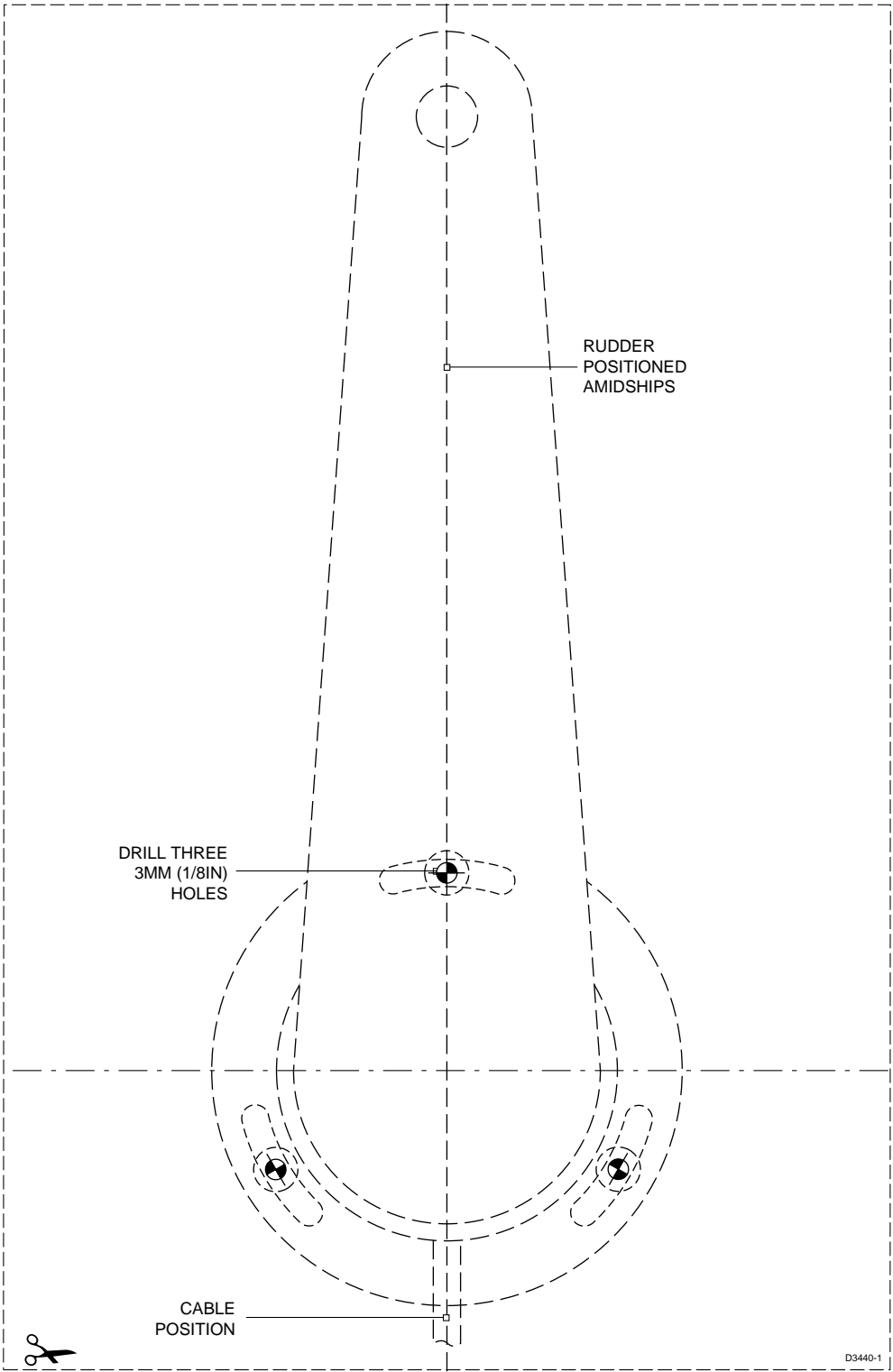

Limited Warranty Certificate

Raymarine warrants each new Light Marine/Dealer Distributor Product to be of good materials and workmanship, and will repair or exchange any parts proven to be defective in material and workmanship under normal use for a period of 2 years/24 months from date of sale to end user, except as provided below.

Defects will be corrected by Raymarine or an authorized Raymarine dealer. Raymarine will, except as provided below, accept labor cost for a period of 2 years/24 months from the date of sale to end user. During this period, except for certain products, travel costs (auto mileage and tolls) up to 100 round trip highway miles (160 kilometres) and travel time of 2 hours, will be assumed by Raymarine only on products where proof of installation or commission by authorized service agents, can be shown.

Warranty Limitations

Raymarine Warranty policy does not apply to equipment which has been subjected to accident, abuse or misuse, shipping damage, alterations, corrosion, incorrect and/or non-authorized service, or equipment on which the serial number has been altered, mutilated or removed.

Except where Raymarine or its authorized dealer has performed the installation, it assumes no responsibility for damage incurred during installation.

This Warranty does not cover routine system checkouts or alignment/calibration, unless required by replacement of part(s) in the area being aligned.

A suitable proof of purchase, showing date, place, and serial number must be made available to Raymarine or authorized service agent at the time of request for Warranty service.

Consumable items, (such as: Chart paper, lamps, fuses, batteries, styli, stylus/drive belts, radar mixer crystals/diodes, snap-in impeller carriers, impellers, impeller bearings, and impeller shaft) are specifically excluded from this Warranty.

Magnetrons, Cathode Ray Tubes (CRT), TFT Liquid Crystal Displays (LCD) and cold cathode fluorescent lamps (CCFL), hailer horns and transducers are warranted for 1 year/12 months from date of sale. These items must be returned to a Raymarine facility.

All costs associated with transducer replacement, other than the cost of the transducer itself, are specifically excluded from this Warranty.

Overtime premium labor portion of services outside of normal working hours is not covered by this Warranty.

Travel cost allowance on certain products with a suggested retail price below \$2500.00 is not authorized. When/or if repairs are necessary, these products must be forwarded to a Raymarine facility or an authorized dealer at owner's expense will be returned via surface carrier at no cost to the owner.

Travel costs other than auto mileage, tolls and two (2) hours travel time, are specifically excluded on all products. Travel costs which are excluded from the coverage of this Warranty include but are not limited to: taxi, launch fees, aircraft rental, subsistence, customs, shipping and communication charges etc. Travel costs, mileage and time, in excess to that allowed must have prior approval in writing.

TO THE EXTENT CONSISTENT WITH STATE AND FEDERAL LAW:

(1) THIS WARRANTY IS STRICTLY LIMITED TO THE TERMS INDICATED HEREIN, AND NO OTHER WARRANTIES OR REMEDIES SHALL BE BINDING ON RAYMARINE INCLUDING WITHOUT LIMITATION ANY WARRANTIES OF MERCHANTABILITY OR FITNESS FOR A PARTICULAR PURPOSE.

(2) Raymarine shall not be liable for any incidental, consequential or special (including punitive or multiple) damages.

All Raymarine products sold or provided hereunder are merely aids to navigation. It is the responsibility of the user to exercise discretion and proper navigational skill independent of any Raymarine equipment.

Raymarine

Factory Service Centers

United States of America

Raymarine Inc
22 Cotton Road, Unit D
Nashua, NH 03063-4219, USA
Telephone: +1 603 881 5200
Fax: +1 603 864 4756
www.raymarine.com

Sales & Order Services

Telephone: +1 800 539 5539 Ext. 2333 or
+1 603 881 5200 Ext. 2333

Technical Support

Telephone: +1 800 539 5539 Ext. 2444 or
+1 603 881 5200 Ext. 2444
Email: techsupport@raymarine.com

Product Repair Center

Telephone: +1 800 539 5539 Ext. 2118

UK, Europe, Middle East, Far East

Raymarine Ltd
Anchorage Park, Portsmouth
PO3 5TD, England
Telephone: +44 (0)23 9269 3611
Fax: +44 (0)23 9269 4642
www.raymarine.com

Customer Support

Telephone: +44 (0)23 9271 4713
Fax: +44 (0)23 9266 1228

Email: techsupport@raymarine.com

Stick barcode label here

Purchased from

Purchase date

Dealer address

Installed by

Installation date

Commissioned by

Commissioning date

Owner's name

Mailing address

This portion should be completed and retained by the owner.