

AIS500

AUTOMATIC IDENTIFICATION SYSTEM

AUTOMATIC IDENTIFICATION SYSTEM
AIS500 Transceiver

Installation instructions

Raymarine®

Trademarks and registered trademarks

Autohelm, HSB, RayTech Navigator, Sail Pilot, SeaTalk and Sportpilot are UK registered trademarks of Raymarine UK Limited. Pathfinder and Raymarine are UK registered trademarks of Raymarine Holdings Limited. 45STV, 60STV, AST, Autoadapt, Auto GST, AutoSeastate, AutoTrim, Bidata, G Series, HDFI, LifeTag, Marine Intelligence, Maxiview, On Board, Raychart, Raynav, Raypilot, RayTalk, Raystar, ST40, ST60+, Seaclutter, Smart Route, Tridata, UniControl and Waypoint Navigation are trademarks of Raymarine UK Limited.

All other product names are trademarks or registered trademarks of their respective owners.

Copyright ©2008 Raymarine UK Ltd. All rights reserved.

ENGLISH

Document number: 87112-1

Date: November 2008

Contents

Chapter 1 Introduction	7	Chapter 5 Post installation procedures.....	35
Applicability	7	5.1 Switching on	36
Safety information.....	7	5.2 Configuration	36
General information	8	5.3 Checking for interference.....	37
Requirements for USA & Canada	9	5.4 Using AIS	38
Requirements for areas outside of USA & Canada.....	11	Chapter 6 Diagnostics.....	39
System information	13	6.1 Status indication	40
Chapter 2 Planning the installation	17	6.2 Troubleshooting	41
2.1 EMC installation guidelines	18	Chapter 7 Specifications.....	43
2.2 Parts supplied	19	7.1 General	44
2.3 Tools required	19	7.2 Transceiver.....	44
2.4 Basic system	20	7.3 GPS Receiver.....	45
Chapter 3 Cables & connections	23		
3.1 Cable types and length	24		
3.2 Routing cables	24		
3.3 Transceiver connections	25		
3.4 Cable shielding	26		
Chapter 4 Installation procedures	27		
4.1 Fitting transceiver.....	28		
4.2 Fitting GPS antenna	29		
4.3 Connecting up	31		

Chapter 1: Introduction

Applicability

The information in this book applies to all geographical areas unless otherwise stated.

Safety information



Warning: Product installation

This equipment must be installed in accordance with the Raymarine instructions provided. Failure to do so could result in poor product performance, personal injury, and/or damage to the vessel.



Warning: Switch off power supply

Ensure the boat's power supply is switched OFF before starting to install this product. Do NOT connect or disconnect equipment with the power switched on, unless instructed in this document.



Warning: Potential ignition source

This product is NOT approved for use in hazardous/flammable atmospheres. Do NOT install in a hazardous/flammable atmosphere (such as in an engine room or near fuel tanks).



Warning: Ensure safe navigation

This product is intended only as an aid to navigation and must never be used in preference to sound navigational judgment. Only official government charts and notices to mariners contain all the current information needed for safe navigation, and the captain is responsible for their prudent use. It is the user's responsibility to use official government charts, notices to mariners, caution and proper navigational skill when operating this or any other Raymarine product.

Caution: Power supply protection

When installing this product ensure the power source is adequately protected by means of a suitably-rated fuse or automatic circuit breaker.

Safety Notice

RF radiation statement

Your Raymarine AIS500 transceiver generates and radiates radio frequency (RF) electromagnetic energy (EME).

Safe Compass Distance

Safe Compass Distance is 1 meter minimum for any compass. Some compass types may require greater distances. To be sure, you should locate your transceiver as far as possible from the compass. Test your compass to verify proper operation while the transceiver is also operating.

General information

Intended Use

Raymarine AIS500 is an AIS Class B transceiver, and is intended for world wide use aboard leisure marine boats and workboats not covered by International Maritime Organization (IMO) and Safety of Life at Sea (SOLAS) Carriage Regulations.

Caution: Cleaning

When cleaning this product do NOT use acid, ammonia-based or abrasive products, and do NOT use high pressure washing (jet wash) equipment.

Product disposal

Dispose of this product in accordance with the WEEE Directive.



The Waste Electrical and Electronic Equipment (WEEE) Directive requires the recycling of waste electrical and electronic equipment. Whilst the WEEE Directive does not apply to some Raymarine products, we support its policy and ask you to be aware of how to dispose of this product.

AIS disclaimer

All information presented by the Raymarine AIS transceiver is advisory only, as there is a risk of incomplete and erroneous information. By placing the AIS500 into service you acknowledge this and assume complete responsibility for any risks associated with this device, and accordingly release Raymarine and SRT Marine Technology Ltd from any and all claims arising from the use of the AIS service.

Warranty registration

To register your AIS500 transceiver ownership, please take a few minutes to fill out the warranty registration card found in the box, or visit www.raymarine.com and register on-line.

It is important that you register your product to receive full warranty benefits. Your unit package includes a bar code label indicating the serial number of the unit. You should stick this label to the warranty registration card.

Technical accuracy

To the best of our knowledge, the information in this document was correct at the time it was produced. However, Raymarine cannot accept liability for any inaccuracies or omissions it may contain. In addition, our policy of continuous product improvement may change specifications without notice. As a result, Raymarine cannot accept liability for any differences between the product and this document.

AIS500 installation guide

Information scope

This document gives introductory, installation and troubleshooting information for the Raymarine Automatic Identification System Type 500 Transceiver (AIS500) transceiver.

Refer to the *ProAIS User Manual* and the operating manual for your Raymarine Multi-Function Display, for instructions on how to configure and operate your AIS system.

All documents are available to download as PDFs from www.raymarine.com

Static data requirement

The AIS500 transceiver needs to be correctly programmed with the following vessel data (static data) before use:

- Vessel Maritime Mobile Service Identity (MMSI) number
- Vessel name
- Vessel call sign
- Vessel dimensions including AIS GPS antenna location
- Vessel type

A MMSI number comprises 9 digits, and a full, valid 9 digit value must be entered in order to be accepted during setup. Any number that does not meet these criteria will not be accepted by the system. All other fields (i.e. vessel type, name etc.) are optional.

If your vessel already has an MMSI number (used for a VHF DSC radio) then the same MMSI number must be used to program the transceiver.

If a valid MMSI number is not entered, the AIS500 will enter Silent Mode and will not transmit. However, it will still operate as a receiver.

Important: In the United States of America, the MMSI and Static Data must be entered only by a Raymarine dealer or other appropriately qualified installer of marine communications equipment on board vessels. The user is NOT authorized to do this.

In Europe and other parts of the world outside of the United States of America, the MMSI and Static Data can be set up by the user.

For further details, refer to the requirements for the area in which you are operating .

Requirements for USA & Canada

Important information

AIS500 conforms to the relevant FCC requirements

Raymarine AIS transceivers comply with the Federal Communications Commission (FCC) and Industry Canada requirements that regulate marine AIS and VHF radio usage for the US and Canada, respectively. Marine AIS users in the US must comply with all applicable FCC rules and regulations, some of which are described in this handbook. This information was current at the time this handbook was printed. Up-to date information, including licensing requirements, can be obtained on the FCC website at: www.fcc.gov/wtb/marine

Official FCC forms can be obtained on the FCC website at: www.fcc.gov/formpage.html

FCC Notice

Compliance statement

This device complies with part 15 of the FCC Rules. Operation is subject to the following two conditions:

1. This device may not cause harmful interference, and
2. This device must accept any interference received, including interference that may cause undesired operation.

Changes or modifications to this equipment not expressly approved in writing by Raymarine Incorporated could violate compliance with FCC rules and void the operator's authority to operate the equipment.

Station Licence

FCC station license requirement

An FCC Ship Radio Station License and Call Sign are not required for most recreational vessels travelling in US waters. However, you must obtain a license if your vessel travels to foreign ports.

Ships that use MF/HF single side-band radio, satellite communications, or telegraphy must be licensed by the FCC. You

can obtain a Station License by filing FCC Form 605, which is available from the FCC website listed above.

Operator License

FCC operator license requirement

An Operator License is not required to operate a Class B AIS Transceiver within US territorial waters. However, a license is required to operate the transceiver if you dock in a foreign port (including Canada and Mexico) or leave a foreign port to dock in a US. port. You can request a Restricted Radiotelephone Operator Permit from the FCC by filing Form 753.

Industry Canada

Industry Canada license requirement

You do not need a license to operate this transceiver within sovereign waters of Canada or the US. You will need a license to operate this radio outside of Canada or the US. To obtain Industry Canada licensing information, contact the nearest field or regional office, or write:

Industry Canada Radio Regulatory Branch
Attention: DOSP
300 Slater Street
Ottawa, Ontario
Canada, KIA 0C8

The following information about the radio is required to complete the license application:

- Industry Canada Certification Number: 4069B-AIS500
- FCC Type Number: PJ5-AIS500
- FCC Type Accepted: Parts 15 and 80

- Output Power: 2 Watts
- Modulation: GMSK
- Frequency Range: 156.025 to 162.025 MHz

Maritime Mobile Service Identity (MMSI)

A nine-digit Maritime Mobile Service Identity (MMSI) number is required to operate the AIS500 transceiver.

Note: You can request an MMSI number from the FCC when you apply for a Station License. If your vessel does not require a license, you may obtain an MMSI by contacting BoatUS (www.boatus.com). Once obtained, you can program the MMSI number into your AIS500 as described in the documentation accompanying the transceiver.

Programming the MMSI & static data

Important: In the United States of America, it is a violation of the rules of the Federal Communications Commission to input an MMSI that has not been properly assigned to the end user or to otherwise input any inaccurate data in this device. The MMSI and Static Data must be entered only by a Raymarine dealer or other appropriately qualified installer of marine communications equipment on board vessels. Instructions for entering the MMSI and static data are given in the documentation on the CDROM supplied with the AIS500 transceiver.

Once static data has been programmed, you must not change it. If the information programmed is no longer correct, contact the Raymarine help desk or the dealer or retailer from whom you purchased the transceiver, to arrange reprogramming.

Antenna Mounting & EME Exposure

This system has a Maximum Permissible Exposure (MPE) Radius of 1.5 meters (per OET Bulletin 65), assuming the maximum power of the radio and antennas with a maximum gain of 3 dBi. Accounting for the height of an average adult (2 meters) the minimum height of the antenna above the deck to meet RF exposure compliance requirements is 3.5 meters. Do not operate the transceiver when anyone is within the MPE radius of the antenna, unless shielded from the antenna field by a grounded metallic barrier.



Warning: Maximum Permissible Exposure

Failure to observe these guidelines may expose those within the maximum permissible exposure (MPE) radius to RF radiation absorption that exceeds the FCC MPE limit. It is the radio operator's responsibility to ensure that no one comes within this radius.

For optimal radio performance and minimal human exposure to radio frequency electromagnetic energy, make sure the antenna is:

- connected to the radio before transmitting
- located where it will be away from people
- located at least 1.5 meters (5 feet) from the radio's main unit

Requirements for areas outside of USA & Canada

Maritime Mobile Service Identity (MMSI)

A nine-digit Maritime Mobile Service Identity (MMSI) number is required to operate the AIS500 Transceiver. In some areas, a radio operator licence is required before an MMSI number will be issued. You can request an MMSI number from same agency that issues radio or Ship Radio licences in your area. Once obtained, you can program the MMSI number into your AIS500 as described in the documentation on the CDRom supplied with the AIS500 transceiver.

Antenna Mounting & EME Exposure

For optimal radio performance and minimal human exposure to radio frequency electromagnetic energy, make sure the antenna is:

- connected to the radio before transmitting
- properly mounted
- located where it will be away from people
- located at least 1.5 metres (5 feet) from the radio's main unit

List of Countries

In Europe, the AIS500 transceiver may be used in the following countries:

Austria	Liechtenstein
Belgium	Lithuania
Bulgaria	Luxembourg
Croatia	Macedonia, former Yugoslav Republic of
Cyprus	Malta

Czech Republic	Netherlands
Denmark	Norway
Estonia	Poland
Finland	Portugal
France	Romania
Germany	Slovakia
Greece	Slovenia
Hungary	Spain
Iceland	Sweden
Ireland	Switzerland
Italy	Turkey
Latvia	United Kingdom

Declaration of Conformity

Certificate No.	Raymarine	
RT081		
<h1>EC Declaration of Conformity</h1>		
We	Raymarine UK Limited,	of Robinson Way Anchorage Park Portsmouth Hampshire England PO3 5TD
<i>declare, under our sole responsibility, that the product identified in this declaration, and to which this declaration relates, is in conformity with the essential requirements of European Parliament and Council Directive:</i>		
<i>1999/5/EC on radio equipment and telecommunications terminal equipment and the mutual recognition of their conformity.</i>		
Product Name:	Raymarine AIS500 AIS Class B Transceiver	
Product Number:	E62235	
<i>The product has been assessed in accordance with the Conformity Procedures in Article 10 and detailed in Annexes III and IV of the Directive and by application of all or part of the following standard(s):</i>		
For Article 3.1(a) [Health]		
EN50384:2002 for occupational exposure to electromagnetic fields		
EN50385:2002 for general public exposure to electromagnetic fields		
EN50383:2002 which is referenced by the preceding two standards		
[Safety]		
EN60945:2002		
EN60950-1:2006 – relevant sections not addressed by the immediately preceding standard		
For Article 3.1(b) [EMC]		
EN301-843-1 v1.2.1 (2004-06)		
EN60945:2002		
For Article 3.2 [Spectrum usage]		
IEC 62287-1: 2006-03 Clause 11, for the AIS transmitter and receivers		
IEC 62287-1: 2006-03 Annex C, Clause C4, for the DSC receiver		
IEC 61108-1: 2003-07 Clauses 4.3.7 & 4.3.8, for the GPS receiver		
For Article 3.3(e) [Access to emergency services]		
IEC 62287-1: 2006-03 Clause 9, for operation in intended environment		
IEC 62287-1: 2006-03 Clauses 10, 12, 13 for operational requirements		
<i>The assessment is consistent with a Technical Construction File showing conformity with the essential requirements of the Directive and has been reviewed by Notified Body No. 0168</i>		
<i>The CE mark has been affixed to the product, together with the identification number of the Notified Body.</i>		
<i>Technical documentation for this product is held by:</i>		
<i>Software Radio Technology plc, of Wireless House, Westfield Industrial Estate, Midsomer Norton, Bath, BA3 4BS</i>		
Signatory:	Name Title Company Name	Gordon Pope Director of Engineering Raymarine UK Limited
	Signature	_____
	Date	3rd February 2009
CE0168D		

D11635-1

System information



Warning: AIS limitation

Never assume that your AIS is detecting all vessels in the area. Always exercise due prudence and do not use AIS as a substitute for sound navigational judgement.

Overview

The AIS500 uses digital radio signals to exchange 'real-time' information between vessels and shore based stations on dedicated VHF frequencies. This information is used to identify and track vessels in the surrounding area and to provide fast, automatic and accurate collision avoidance data.

Although AIS augments your radar application by operating in radar blind spots and detecting smaller AIS-fitted vessels, it does not replace radar, as it relies on receiving transmitted AIS information and therefore cannot detect objects such as landmasses and navigational beacons.

NEVER assume that AIS is displaying information from all vessels in the area, because:

- Not all vessels are fitted with AIS
- Although it is mandatory for larger commercial vessels to carry AIS, it is not mandatory to use it.

AIS should be used only to augment radar information, not substitute it.

Classes of AIS

Your AIS500 is a transceiver that receives messages from and transmits messages to vessels carrying Class A or Class B transceivers.

Class A Transceivers

Class A AIS transceivers transmit and receive AIS signals. AIS transceivers are currently mandatory on all commercial vessels exceeding 300 tons that travel internationally (SOLAS vessels).

The following information can be transmitted by a Class A AIS system:

- Static data. Includes information such as vessel name, vessel type, MMSI number, call sign, IMO number, length, beam and GPS antenna location.
- Voyage related data. Includes information such as draft, cargo, destination, ETA and other relevant information.
- Dynamic data. Includes information such as time (UTC), ship's position, COG, SOG, heading, rate of turn and navigational status.
- Dynamic reports. Ship's speed and status.
- Messages. Alarms and safety messages.

Remember that not all vessels will transmit all of the information.

Class B Transceivers

Class B AIS transceivers transmit and receive AIS signals, but use a reduced set of data compared to Class A (see *Data Summary*). A Class B AIS transceiver can be fitted on any vessel not fitted with a Class A transceiver, but is not mandatory aboard any vessel.

Your AIS500 transceiver is a Class B transceiver.

Data Summary

Data	Class A (receive)	Class B (send)	Class B (receive)
Ship's name	Yes	Yes	Yes
Type	Yes	Yes	Yes

Data	Class A (receive)	Class B (send)	Class B (receive)
Call sign	Yes	Yes	Yes
IMO number	Yes	No	No
Length and beam	Yes	Yes	Yes
Antenna location	Yes	Yes	Yes
Draft	Yes	No	No
Cargo Information	Yes	Yes	Yes
Destination	Yes	No	No
ETA	Yes	No	No
Time	Yes	Yes	Yes
Ship's position	Yes	Yes	Yes
COG	Yes	Yes	Yes
SOG	Yes	Yes	Yes
Gyro heading	Yes	Yes*	Yes
Rate of turn	Yes	No	No
Navigational status	Yes	No	No
Safety message	Yes	No	Yes

*Class B transceivers do not transmit a Gyro heading unless the transceiver is receiving an NMEA HDT sentence from an external source.

Data reporting intervals

AIS information is classed as either static or dynamic. Static information is broadcast, when data has been amended, or upon request, or by default, every 6 minutes.

The reporting rates for dynamic information depend on speed and course change, and are given in the following tables.

Note: The reporting rates shown here are for reference and may not be the rate at which information is actually received by an AIS500 Transceiver. This is dependent on a number of factors, including but not limited to antenna height, gain and signal interference.

Class A systems

Ships Dynamic Conditions	Reporting rate
At anchor or moored	3 Minutes
0-14 knots	10 Seconds
0-14 knots and changing course	3 $\frac{1}{3}$ Seconds
14-23 knots	6 Seconds
14-23 knots and changing course	2 seconds
Faster than 23 knots	2 seconds
Faster than 23 knots and changing course	2 seconds

Class B systems

Ships Dynamic Conditions	Reporting rate
0 to 2 knots	3 Minutes
Above 2 knots	30 Seconds

Other AIS sources

Source	Reporting rate
Search and Rescue (SAR) aircraft	10 seconds
Aids to navigation	3 minutes
AIS base station	10 seconds or 3.33 seconds, depending on operating parameters

Chapter 2: Planning the installation

Chapter contents

- [2.1 EMC installation guidelines on page 18](#)
- [2.2 Parts supplied on page 19](#)
- [2.3 Tools required on page 19](#)
- [2.4 Basic system on page 20](#)

2.1 EMC installation guidelines

Raymarine equipment and accessories conform to the appropriate Electromagnetic Compatibility (EMC) regulations, to minimize electromagnetic interference between equipment and minimize the effect such interference could have on the performance of your system

Correct installation is required to ensure that EMC performance is not compromised.

For **optimum** EMC performance we recommend that wherever possible:

- Raymarine equipment and cables connected to it are:
 - At least 1 m (3 ft) from any equipment transmitting or cables carrying radio signals e.g. VHF radios, cables and antennas. In the case of SSB radios, the distance should be increased to 7 ft (2 m).
 - More than 2 m (7 ft) from the path of a radar beam. A radar beam can normally be assumed to spread 20 degrees above and below the radiating element.
- The product is supplied from a separate battery from that used for engine start. This is important to prevent erratic behavior and data loss which can occur if the engine start does not have a separate battery.
- Raymarine specified cables are used.
- Cables are not cut or extended, unless doing so is detailed in the installation manual.

Note: Where constraints on the installation prevent any of the above recommendations, always ensure the maximum possible separation between different items of electrical equipment, to provide the best conditions for EMC performance throughout the installation

Suppression ferrites

Raymarine cables may be fitted with suppression ferrites. These are important for correct EMC performance. If a ferrite has to be removed for any purpose (e.g. installation or maintenance), it must be replaced in the original position before the product is used.

Use only ferrites of the correct type, supplied by Raymarine authorized dealers.

Connections to other equipment

Requirement for ferrites on non-Raymarine cables

If your Raymarine equipment is to be connected to other equipment using a cable not supplied by Raymarine, a suppression ferrite **MUST** always be attached to the cable near the Raymarine unit.

2.2 Parts supplied

Check all parts are present.

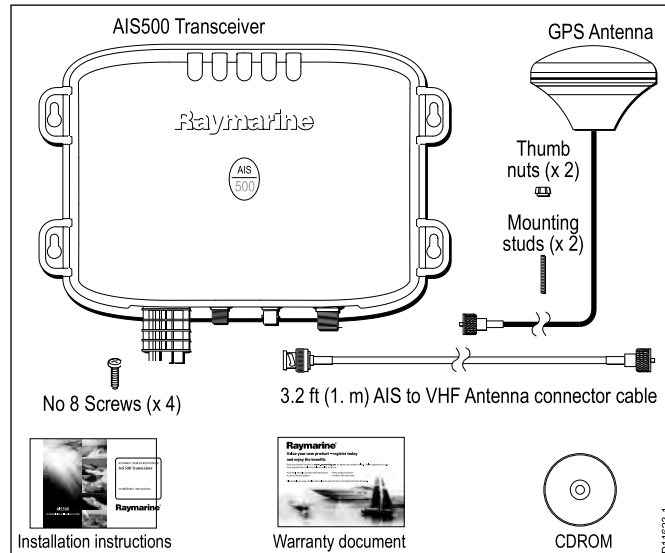

2.3 Tools required

Ensure you have these tools before starting installation.

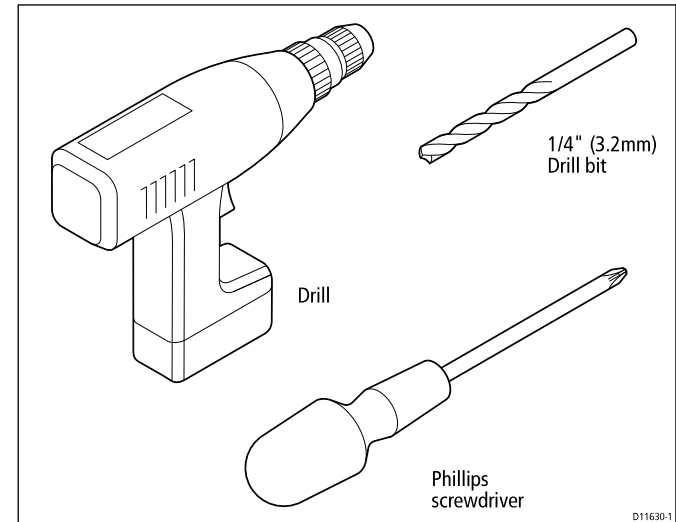

2.4 Basic system

The following illustration shows a basic AIS500 system.

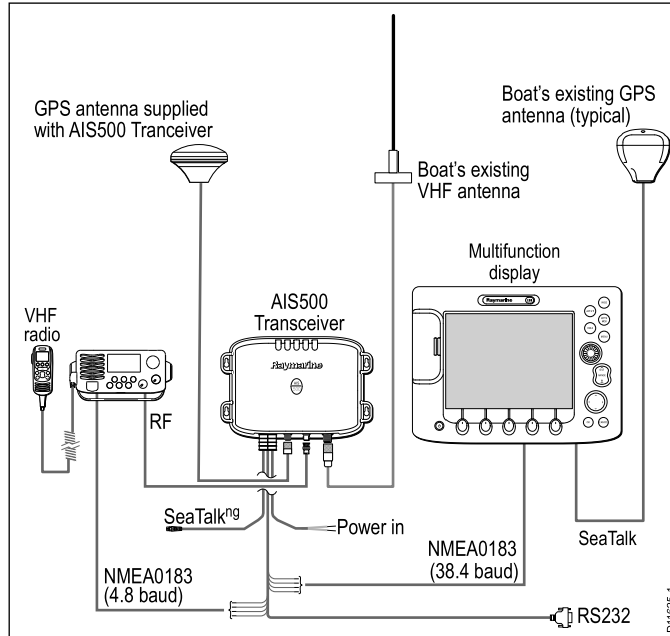

AIS500 dimensions

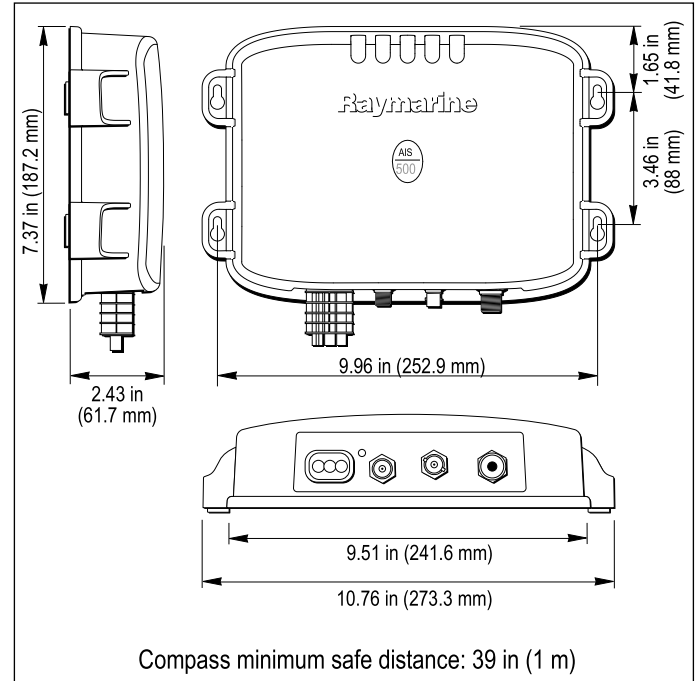

Site requirements

When planning the installation, take the following site requirements for the AIS500 transceiver and GPS antenna, into account.

AIS500 transceiver

This product is NOT approved for use in hazardous/flammable atmospheres. Do NOT install in a hazardous/flammable atmosphere (such as in an engine room or near fuel tanks).

The AIS500 transceiver must be fitted in a location where it is not likely to be stepped on or tripped over, and which:

- Is close enough to allow connection to the boat's VHF set with the 3 ft (1 m) RF cable supplied.
- Is at least 3 ft (1 m) from an engine, compass or any magnetic device.
- Has at least 6 in (100 mm) of clear space below, to allow access for cabling and adequate cable bends.
- Is maintained at a temperature between -10°C (14°F) and 55°C (130°F).
- Is maintained in a dry condition and where there is no likelihood of the transceiver being splashed.
- Does NOT have a flammable or hazardous atmosphere.

Power supply

The AIS500 transceiver requires a 12 V dc or 24 V dc power supply, typically from a circuit breaker on the boat's power panel or from a fuse block near the transceiver.

VHF antenna requirement

The AIS500 transceiver requires inputs from both GPS and VHF antenna.

The AIS500 transceiver has an inbuilt VHF splitter to enable you to connect your existing VHF antenna directly to the AIS500 transceiver, then route the split signal from the transceiver to your VHF set. This may cause some degradation of performance of your VHF set. If the level of degradation is unacceptable, we recommend you use separate VHF antennae for the AIS500 and the VHF set.

The loss values for the inbuilt splitter are given in the *Specification* section.

GPS antenna requirement

A GPS antenna is supplied with the transceiver and must be installed in accordance with the instructions given here. Do NOT connect any other GPS antenna to the AIS500 transceiver.

The GPS antenna can be mounted either on a flat horizontal surface or on a suitable pole.

- If you intend surface mounting the antenna, ensure you have access to the underside of the mounting surface.
- If you intend pole-mounting the antenna, the pole needs a 1 inch 14 TPI thread.

Important: The main requirement of the intended location for the GPS antenna is that it gives a good direct line of site to the entire sky, right around the horizon.

Ensure that the intended mounting location is:

- Open and clear of any obstructions (such as masts, search lights, or other structures) that could block line-of-sight to the sky.
- As low as possible, to keep the antenna as stable as possible. The more stable the unit, the more effectively it will track satellites and provide stable data.
- As far as possible (at least 1 m (3 ft)) from other antennae and electronic equipment.

Do NOT mount the antenna:

- In any area where it could be stepped on or tripped over
- Up a mast. This will cause the antenna to swing and give significant errors in position data
- In the direct path of a radar beam.

SeaTalk^{ng} requirement

A fitted SeaTalk^{ng} connector enables you to connect the AIS500 transceiver to SeaTalk^{ng}, aboard vessels on which the multi-function displays are connected via SeaTalk^{ng}.

Before connecting to SeaTalk^{ng}, refer to the *SeaTalk^{ng} Reference Manual*, and ensure that with this product connected, the maximum permitted Load Equivalence Number (LEN) value for the system will not be exceeded.

Note that the AIS500 transceiver has a SeaTalk^{ng} LEN value of 1.

Chapter 3: Cables & connections

Chapter contents

- 3.1 Cable types and length on page 24
- 3.2 Routing cables on page 24
- 3.3 Transceiver connections on page 25
- 3.4 Cable shielding on page 26

3.1 Cable types and length

It is important to use cables of the appropriate type and length

- Unless otherwise stated use only standard cables of the correct type, supplied by Raymarine.
- Ensure that any non-Raymarine cables are of the correct quality and gauge. For example, longer power cable runs may require larger wire gauges to minimize voltage drop along the run.

3.2 Routing cables

Cables must be routed correctly, to maximize performance and prolong cable life.

- Do NOT bend cables excessively. Wherever possible, ensure a minimum bend radius of 100 mm.

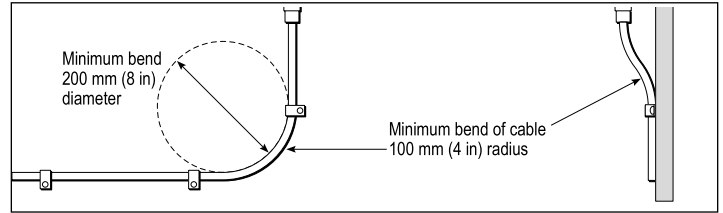

- Protect all cables from physical damage and exposure to heat. Use trunking or conduit where possible. Do NOT run cables through bilges or doorways, or close to moving or hot objects.
- Secure cables in place using tie-wraps or lacing twine. Coil any extra cable and tie it out of the way.
- Where a cable passes through an exposed bulkhead or deckhead, use a suitable watertight feed-through.
- Do NOT run cables near to engines or fluorescent lights.

Always route data cables as far away as possible from:

- other equipment and cables,
- high current carrying ac and dc power lines,
- antennae.

3.3 Transceiver connections

The transceiver has attached cables to provide connections to:

- Power supply
- NMEA0183, 4800 baud
- NMEA0183, 38400 baud
- RS232
- SeaTalk^{ng}

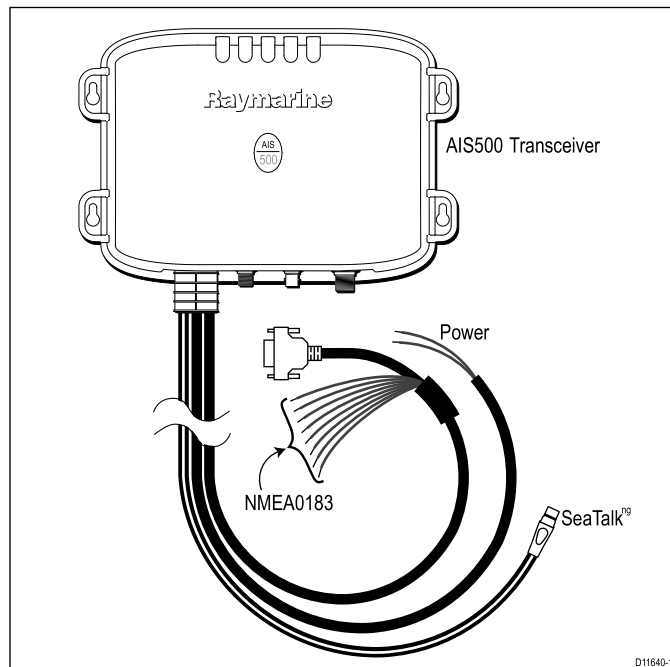

RF connections

In a typical AIS500 system:

- The boat's existing VHF antenna connects to the **ANTENNA** connector on the AIS500 transceiver.
- The supplied 1 m RF cable connects the antenna connector on the boat's existing VHF set, to the **VHF RADIO** connector on the AIS500 transceiver.

If this arrangement results in unacceptable degradation of the performance of the VHF radio, separate antennae should be used for the AIS500 transceiver and the VHF radio. In this case, the supplied 1 m RF cable is not used and the **VHF RADIO** connector on the AIS500 transceiver remains unconnected.

Note that when the AIS500 transceiver transmits, there is a very brief interruption to the boat's VHF receive function. This may be noticeable during when a long, continuous broadcast is being received.

GPS connections

The GPS supplied as part of the AIS500 system has a fitted 10 m (33 ft) cable to connect to the AIS500 transceiver **GPS** connector.

NMEA connections

The AIS500 transceiver has a fitted cable which provides prepared, bare-wire NMEA0183 connections at both 4800 baud and 38400 baud rates, as follows:

Wire color	NMEA0183 Function
Green	4800 baud receive -
White	4800 baud receive +
Brown	4800 baud transmit -

Wire color	NMEA0183 Function
Yellow	4800 baud transmit +
Orange with green stripe	38400 baud receive -
Orange with white stripe	38400 baud receive +
Orange with brown stripe	38400 baud transmit -
Orange with yellow stripe	38400 baud transmit +

A multiplexer built into the transceiver manages both 4800 and 38400 baud rates. This feature effectively frees up an NMEA port on your multi-function display (MFD). If only one NMEA0183 port exists on your equipment, the multiplexer eliminates the need for a separate multiplexer.

Typically the NMEA0183 connections are used as follows:

- The 4800 baud wires connect to the appropriate points on the VHF radio or other NMEA0183 4800 baud input/output device.
- The 38400 baud wires connect to appropriate Raymarine MFDs. The NMEA0183 port on each MFD connected in this manner must be set to 38400 baud.

3.4 Cable shielding

Ensure that all data cables are properly shielded that the cable shielding is intact (e.g. hasn't been scraped off by being squeezed through a tight area).

Chapter 4: Installation procedures

Chapter contents

- [4.1 Fitting transceiver on page 28](#)
- [4.2 Fitting GPS antenna on page 29](#)
- [4.3 Connecting up on page 31](#)

4.1 Fitting transceiver

Ensure that the intended installation site meets the conditions described under Site requirements, mark and drill the mounting holes, then fit the transceiver as shown in the following illustrations.

Note: This procedure shows how to mount the transceiver vertically, which is the recommended method. However, you may mount it horizontally if necessary.

Note: If you are fitting the transceiver to fiberglass that has a gelcoat surface, overdrill the surface to prevent the gelcoat from damage when securing the screws. Before drilling the pilot holes, hand drill the marked locations with an oversized bit and countersink to approximately 9.5 mm (3/8 in) diameter.

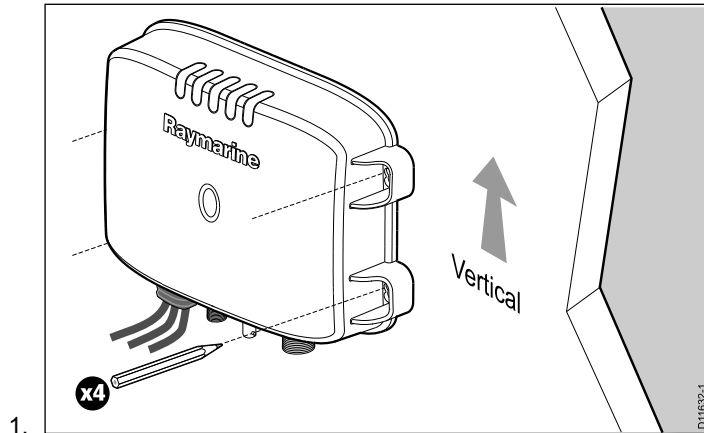

2.

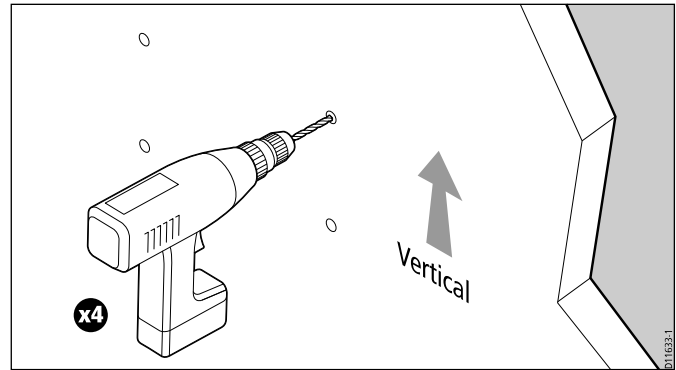

3.

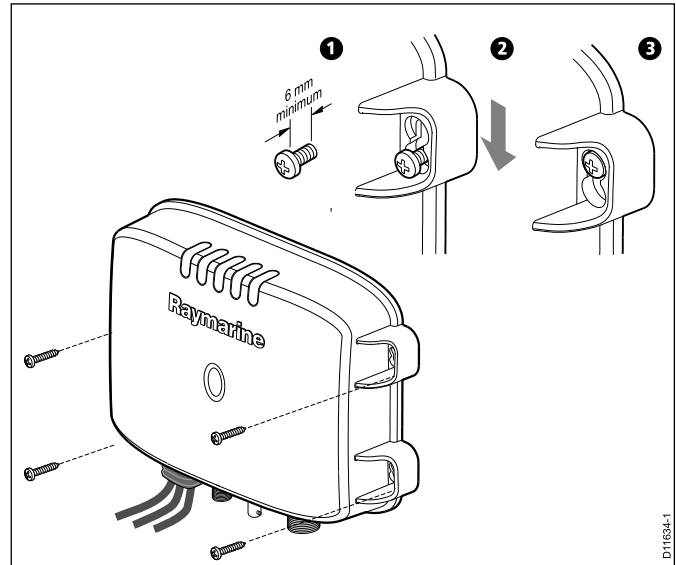

4.2 Fitting GPS antenna

To fit the GPS antenna:

1. Select a suitable location for the GPS antenna as described under *Site requirements*.
2. Fit your GPS antenna using either the *Surface mounting* or *Pole mounting* procedure, as appropriate.
3. Ensuring the conditions in *Running cables* are fulfilled, run the GPS antenna cable to the AIS transceiver.

Surface mounting

When surface mounting the GPS antenna, you can route the cable either centrally (Option A) or from the side of the antenna (Option B).

1. Use the template supplied in this handbook to mark the two 6 mm (0.25 in) mounting holes.
 - OPTION A: If the cable is going to pass through the mounting surface drill a 19 mm (0.75 in) center hole.
 - OPTION B: If the cable is to be routed from the side of the receiver (i.e. above the mounting surface), remove the two plastic tabs (1) obstructing the cable channel. If you do not remove these tabs before using the cable channel, you could damage the cable.

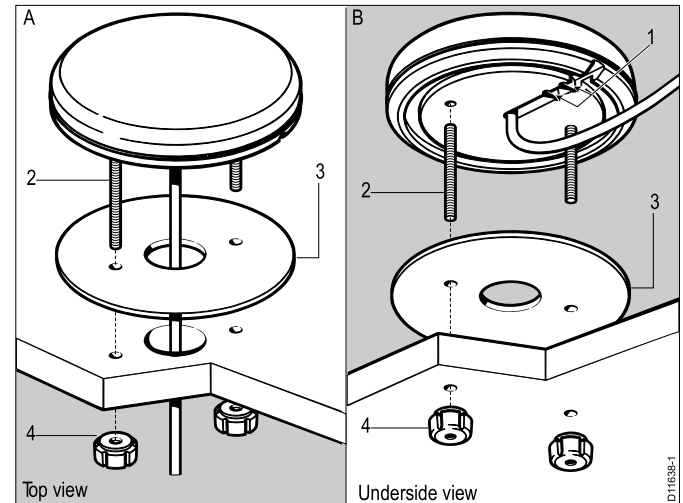

2. Screw the two mounting studs (2) into the underside of the receiver.
3. Stick the supplied gasket (3) to the mounting surface, ensuring that the holes on the gasket correspond with the drilled holes.
4. Route the cable as follows:
 - For Option A, feed the cable down through the center hole.
 - For Option B, route the cable along the cable exit channel.
5. Carefully place the receiver so the mounting studs pass through the holes in the mounting surface.
6. Secure the receiver to the surface using the two thumb nuts (4).

Pole mounting

If you want to pole-mount the GPS antenna, obtain a pole of suitable length with a 1 inch 14 TPI thread.

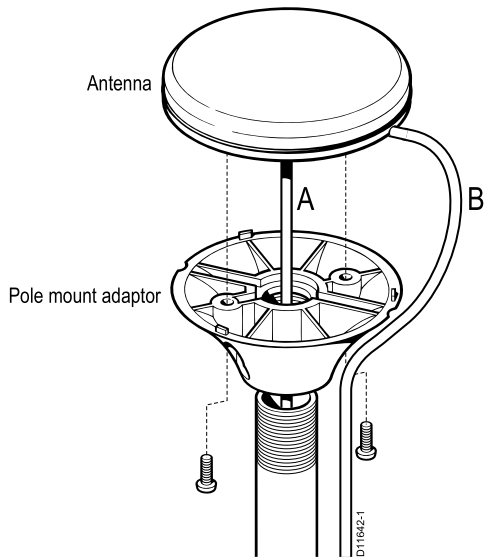

5. Ensuring you do not trap the cable, place the GPS antenna on the pole mount adaptor so the screw holes align, then secure the antenna with the 2 screws retained at step 2.

1. Ensuring that the *Site requirements* are met, securely attach the pole to a suitable, secure point.
2. Remove and retain the screws securing the GPS antenna from the pole mount adaptor, then separate these two items.
3. Screw the pole mount adaptor fully onto the pole and ensure it is secure on the pole.
4. Route the antenna cable as follows:
 - i. If you want to route the antenna cable directly down from the antenna (option A), feed it through the center of the pole mount adaptor and then down through the pole.
 - ii. If you want to route the antenna cable out of the side of the antenna (option B), remove the two plastic tabs from the cable channel, then feed the cable along the channel.

4.3 Connecting up

Carry out the following procedures to connect up the AIS500 system:

- *Connecting GPS*
- *Connecting to VHF*
- *Connecting to multi-function displays*
- *Connecting power*



Warning: Switch off power supply

Ensure the boat's power supply is switched OFF before starting to install this product. Do NOT connect or disconnect equipment with the power switched on, unless instructed in this document.

Connecting GPS

Connect the cable from the GPS antenna to the **GPS** connector on the underside of the AIS transceiver.

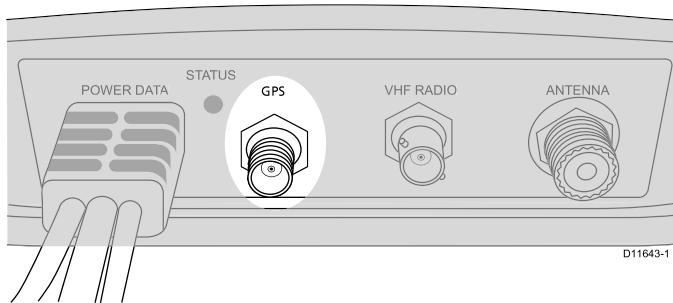

If the GPS antenna is not connected, the transceiver will operate in Silent Mode and an alarm message will be generated. You must acknowledge all alarm messages.

The transceiver will not transmit, but will still receive.

Connecting to VHF

Ensure power to the ship's VHF set is switched off, then connect the AIS500 transceiver by carrying out the *Connecting RF* and the *Connecting NMEA (low baud rate)* procedures.

Connecting RF

At the AIS500 transceiver:

1. Connect the cable from the existing VHF antenna to the **ANTENNA** connector.
2. Using the 1 m (3 ft) RF cable supplied, connect the **VHF RADIO** connector to the antenna connector on the boat's VHF set.

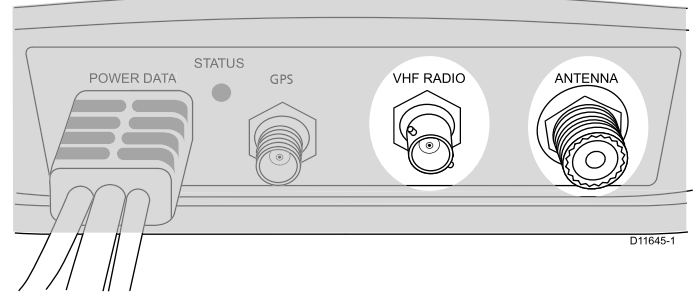

Connecting NMEA0183 (low baud rate)

Connect the AIS500 transceiver 4800 baud NMEA0183 bus to the ship's VHF as follows:

1. Identify the 4800 baud NMEA0183 wires from the AIS500 transceiver.

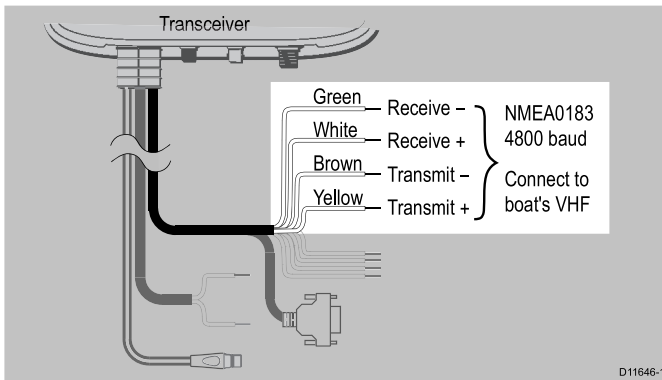

2. Connect these wires to the appropriate points on the ships VHF.

Connecting to multi-function displays

Data is transferred between the AIS500 transceiver and the associated Raymarine multi-function display(s) using either NMEA0183 (at 38400 baud) or SeaTalk^{ng}.

Ensure power to the multi-function displays is switched off, then connect the AIS500 transceiver by carrying out either the *Connect using NMEA0183* OR the *Connect using SeaTalk^{ng}* procedure.

Connect using NMEA0183 (high baud rate)

If your multi-function displays are NOT connected to a SeaTalk^{ng} system, connect the AIS500 transceiver 38400 baud, NMEA0183 bus to the boat's 38400 baud, NMEA0183 system as follows:

1. Identify the 38400 baud, NMEA0183 wires from the AIS500 transceiver.

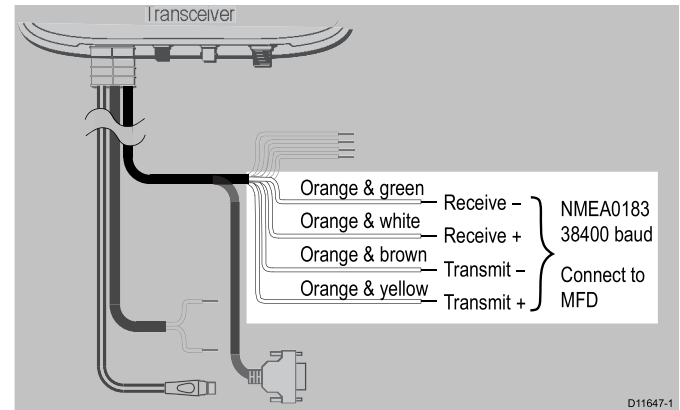

2. Connect these wires to the appropriate points on the boat's 38400 baud, NMEA0183 system.

Connect using SeaTalk^{ng}

Important: Do not connect to a Raymarine SeaTalk^{ng} system, if this will cause the maximum permitted SeaTalk^{ng} Load Equivalence Number (LEN) value for the system to be exceeded (see *Site Requirements*).

If your multi-function displays are connected to a SeaTalk^{ng} system, connect the AIS500 transceiver SeaTalk^{ng} connector to SeaTalk^{ng} as follows:

1. Identify the AIS500 transceiver SeaTalk^{ng} connector.

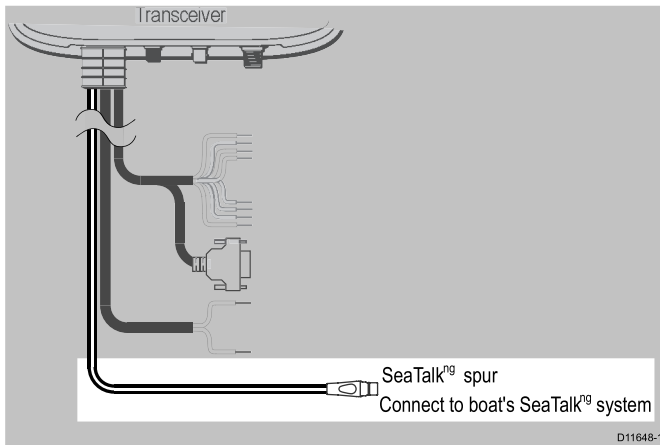

2. Connect to a convenient point on the SeaTalk[®] system.

Connecting power

Power supply protection

Always protect the power supply by connecting the red (positive) wire to the supply via a 5 A fuse or equivalent automatic circuit breaker.

Sharing a breaker

The text within the illustration has been updated for clarity

Where more than 1 piece of equipment shares a breaker you must provide protection for the individual circuits. E.g. by connecting an in-line fuse for each power circuit.

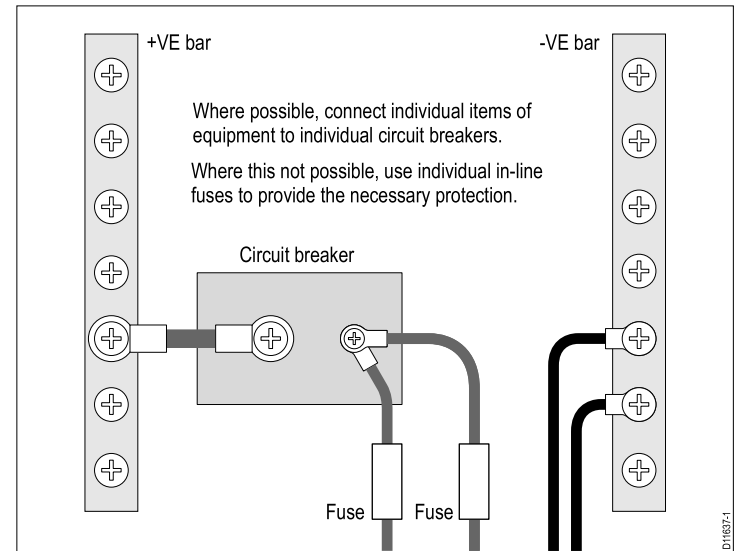

Power connection procedure

The use of crimped and soldered lugs is recommended, to provide optimum connection to the power source.

Connect the AIS500 transceiver power cable to either a 12 V dc or 24 V dc power source as follows:

1. Ensuring the intended power source is switched off, connect the red wire via a 5 A fuse or equivalent automatic circuit breaker to the supply positive terminal.
2. Connect the black wire to the supply negative terminal.

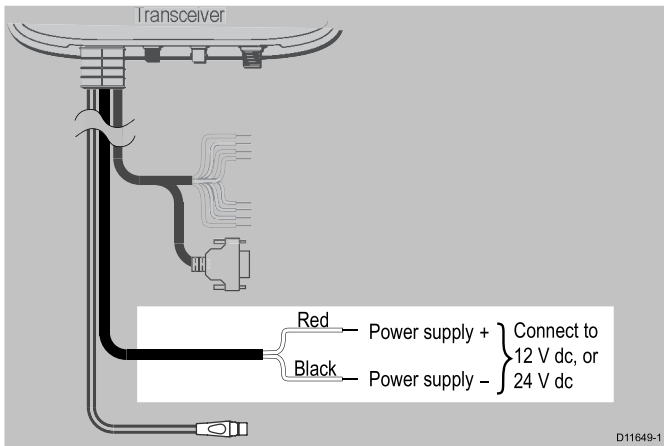

Chapter 5: Post installation procedures

Chapter contents

- 5.1 Switching on on page 36
- 5.2 Configuration on page 36
- 5.3 Checking for interference on page 37
- 5.4 Using AIS on page 38

5.1 Switching on

When the installation is complete, observe the STATUS indicator and:

1. Switch on power to the AIS500 transceiver.
2. Check that:
 - i. When power is first applied, the **STATUS** indicator flashes RED twice, then after a few seconds shows AMBER.
 - ii. After a time (up to 2 minutes) the indicator changes to green. This indicates the AIS500 transceiver is operating normally.

5.2 Configuration



Warning: Configure before use

This Raymarine product must be correctly configured, to ensure optimum performance and minimize the chances of unsafe or other erroneous data.

Configuration requirement

After installation and successful switch on, the AIS500 transceiver must be configured for optimum performance aboard the vessel. The person configuring the AIS500 needs to know the following vessel information:

- MMSI number
- Name
- Call sign
- Dimensions
- Type
- GPS antenna position

The manner in which configuration is carried out depends on the legal requirements of the geographical area you are.

Important: Before starting any AIS configuration procedure, SWITCH OFF all associated multi-function displays (MFDs), otherwise you will not be able to correctly configure your AIS500 transceiver.

USA

In the USA, it is a legal requirement that the configuration is performed by a suitable dealer.

You can use the supplied ProAIS PC software, to check the vessel data programmed into your AIS500. If this information is incorrect please contact your Raymarine dealer before using the transceiver.

Areas outside of USA

In areas outside of the USA, use the supplied ProAIS PC software to configure your AIS500 transceiver, as described in the instructions provided in the *ProAIS User Guide*.

5.3 Checking for interference

Post installation check

If you have installed any system aboard a boat or made other changes to the boat's electronic systems (radar, VHF radio etc.), you need to check before casting off, that all electrical systems operate satisfactorily without any undue electrical interference, in order to conform with Electro Magnetic Compatibility (EMC) regulations. To do this:

1. Ensuring it is safe to do so, turn on all electronic systems aboard the boat.
2. Check that the electronic systems all operate satisfactorily.

5.4 Using AIS

The exact method of using AIS depends on which type of Raymarine multi-function display (MFD) you are using.

Refer to the handbook for your MFD for information on using AIS.

Chapter 6: Diagnostics

Chapter contents

- [6.1 Status indication on page 40](#)
- [6.2 Troubleshooting on page 41](#)

6.1 Status indication

The current operating status of the AIS500 transceiver is shown by a **STATUS** LED on the bottom of the unit.

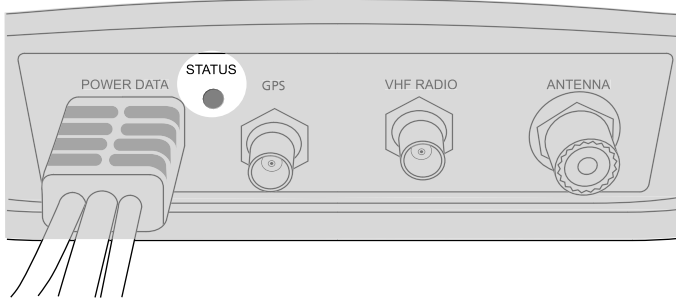

When power is switched on, the **STATUS** indicator flashes RED twice, then after a few seconds it goes to AMBER.

The amber condition continues while the transceiver acquires a GPS fix then transmits a position report. This can take up to 2 minutes.

When the first position report has been transmitted, the **STATUS** indicator goes to GREEN. This condition remains all the time the AIS500 transceiver is operating normally

A summary of **STATUS** indicator colors is as follows:

Color	Status
GREEN	AIS500 transceiver is operating normally
AMBER	Either: <ul style="list-style-type: none">• The AIS500 transceiver is starting up, or• The AIS500 transceiver has not transmitted for more than 2 reporting periods. This could be due to high AIS traffic or loss of GPS fix.

BLUE (continuous)	Running in Silent Mode
BLUE (flash)	Each time AIS data is received
RED	Fault condition. Refer to the Troubleshooting section

6.2 Troubleshooting

Issue	Action
No power	Check: <ul style="list-style-type: none"> • All power connections • Check relevant fuses • That power supply is at the correct voltage (12 V or 24 V)
AIS configuration data is not saved	Switch off all associated multi-function displays (MFDs), then re-configure
No data	Check that: <ul style="list-style-type: none"> • Connections are secure throughout the system • The VHF aerial lead is securely connected and that you can send and receive VHF radio information
No vessel data	At the relevant Raymarine multi function display: <ul style="list-style-type: none"> • Place the cursor over the targeted vessel and ensure the AIS DATA soft key is not set to OFF • Ensure the AIS layer is set to ON • Ensure displayed target types are set to ALL
No AIS data	Check the NMEA output from the multi-function displays to the AIS500 input, and ensure: <ul style="list-style-type: none"> • The wires are correctly connected • The baud rate is 38400 baud

Status indicator remains amber	Wait at least 30 minutes to check that a 'Quiet time' has not been requested by the local authority Check that the: <ul style="list-style-type: none"> • GPS antenna is properly connected • GPS antenna has a clear view of the sky, without any obstructions • MMSI number has been properly configured (use the proAIS application)
Status indicator is red	Check that: <ul style="list-style-type: none"> • The VHF antenna is properly connected and in particular it is not short circuiting to the vessel structure • That power supply is at the correct voltage (12 V or 24 V) • The MMSI number has been properly configured (use the proAIS application)

Chapter 7: Specifications

Chapter contents

- [7.1 General on page 44](#)
- [7.2 Transceiver on page 44](#)
- [7.3 GPS Receiver on page 45](#)

7.1 General

Waterproofing	IPX2
Operating temperature range	-10°C to +55° C (14°F to 131°F)
Storage temperature range	-20°C to +75° C (-4°F to 167°F)
Humidity	Up to 95% at 35° non-condensing
Power supply voltage	12 V to 24 V dc, reverse polarity protected
Supply current at 12 V dc	Nominal: 0.62 A Peak (during transmit): 2.1 A
Size	273.3 mm x 187.2 mm x 61.7 mm (10.76 in x 7.37 in x 2.43 in)
Weight	1.19 kg (2.63 lb)
Mounting	Four keyholed mounting tabs and mounting screws
Connectors	VHF antenna – SO-239 VHF In – BNC GPS In – TNC PC RS232 – 9 Way D Type NMEA0183 HS – stripped wires NMEA0183 LS – stripped wires Power – stripped wires SeaTalk ^{ng} - proprietary Raymarine connector
NMEA sentences	!AIVDO, !AIVDM, !AIALR, and !AITXT
• With NMEA GPS output ON	\$GPGLL, \$GPGGA, \$GPVTG, \$GPGSV, \$GPGSA, \$GPZDA, \$GPRMC, and \$GPGBS
VHF splitter losses	Receive: less than 4 dB Transmit: less than 1 dB

7.2 Transceiver

Operating frequency range	156.025 MHz to 162.025 MHz
Channel spacing	25 kHz
Receivers	2 receivers
Receiver sensitivity	<-107 dBm
Transmitter	1 transmitter
Transmitter output power	2 W (33 dBm)
Transceiver standard	Class B 'CS' AIS to IEC62287-1

7.3 GPS Receiver

Receiver channels	16
Receiver sensitivity	Acquisition -140 dBm Tracking -150 dBm
Nominal Time to First Fix	34 seconds

Raymarine[®]
...world leaders in marine electronics.

www.raymarine.com

CE0168

www.busse-yachtshop.de | info@busse-yachtshop.de