

ST40 Speed Instrument Owner's Handbook

Document number: 81157_2
Date: 1st May 2001

Important information

WARNING

Although your ST40 instrument is designed to give accurate and reliable performance, it should serve only as an aid to navigation and should never lead to the erosion of good seamanship. Always maintain a permanent watch and be aware of situations as they develop.

EMC conformance

All Raymarine equipment and accessories are designed to the best industry standards for use in the leisure marine environment.

The design and manufacture of Raymarine equipment and accessories conform to the appropriate Electromagnetic Compatibility (EMC) standards, but correct installation is required to ensure that performance is not compromised.

Handbook information

To the best of our knowledge, the information in this handbook was correct when it went to press. However, the Raymarine policy of continuous product improvement may change product specifications without notice. Consequently, unavoidable differences may occur between the product and the handbook from time to time, for which Raymarine cannot accept liability.

Contents

- Important information i**
 - WARNING i
 - EMC conformance i
 - Handbook information i

- Preface v**
 - Parts supplied vi

- Chapter 1: Operation 1**
 - 1.1 Introduction 1
 - 1.2 Operating procedures 1
 - Adjusting display backlighting and contrast 3

- Chapter 2: Maintenance and Fault Finding 5**
 - 2.1 Maintenance 5
 - Servicing and safety 5
 - Instrument 6
 - Transducer 6
 - Cabling 6
 - 2.2 Fault finding 6
 - Preliminary procedures 6
 - Fixing faults 6
 - Assistance 8

- Chapter 3: Installation 9**
 - 3.1 Planning your installation 9
 - EMC installation guidelines 9
 - Suppression Ferrites 10
 - Connections to Other Equipment 10
 - Tools required 10

Site requirements	11
Transducer	11
Instrument	13
3.2 Procedures	13
Fitting transducer	13
Running transducer cable	14
Connections to the instrument	14
Stand-alone connections	15
SeaTalk connections	16
Fitting the instrument	16
3.3 Calibration requirement	19
Chapter 4: Calibration	21
4.1 Introduction	21
EMC conformance	21
4.2 User calibration	21
4.3 Intermediate calibration	23
4.4 Dealer calibration	23
Instrument Specification	25
Glossary	27
Index	29

Preface

Thank you for purchasing a Raymarine product. We are sure your ST40 instrument will give you many years of trouble-free operation.

This instrument is designed to provide reliable performance, even under the most demanding conditions.

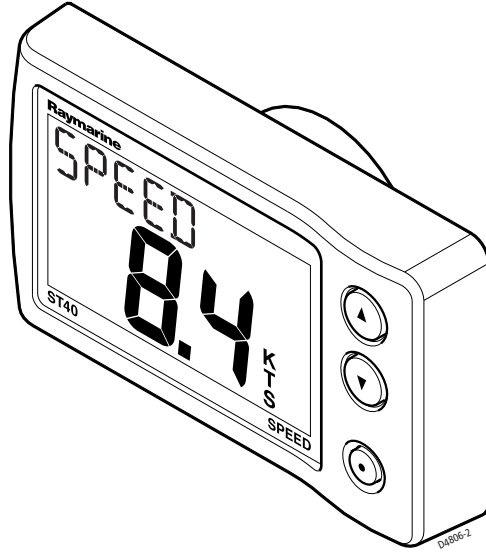

Parts supplied

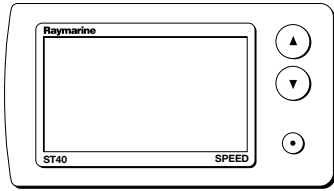

ST40 Speed instrument

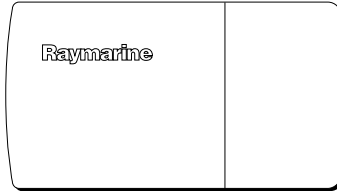

Instrument Cover

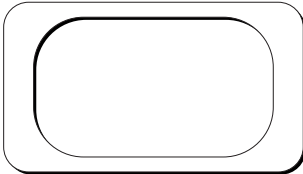

Gasket

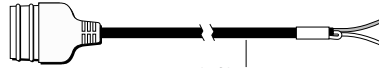

1 m (3 ft) power cable

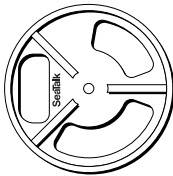

Clamping bracket

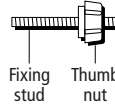
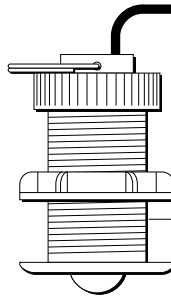

Fixing stud

Thumb nut

Speed transducer
Supplied with bung
(not illustrated)

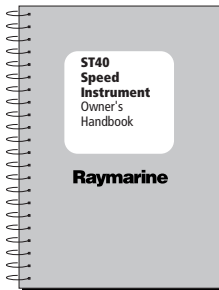

Owner's Handbook.
Warranty document and fitting
templates included in Handbook

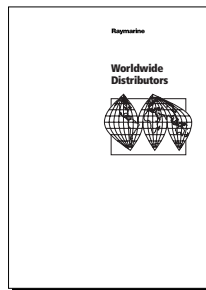

Worldwide Service Centre
Handbook.

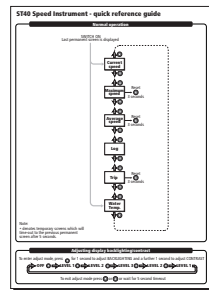

Quick Reference Guide

Note:

The items shown here are supplied for an ST40 Speed system. If an instrument is purchased separately, a transducer is not included. If any item is not present, contact your Raymarine Dealer.

Chapter 1: Operation

1.1 Introduction

Your ST40 Speed instrument provides:

- Speed information (current, maximum and average), in either knots (KTS), miles per hour (MPH) or kilometres per hour (KPH).
- Log and trip information. These are given in either nautical miles (NM), statute miles (M) or kilometres (KM).
- Water temperature information. This is given in either degrees Celsius (°C) or Fahrenheit (°F).

Note: *The required speed, distance and water temperature units are selected during User calibration (see Chapter 4, Calibration).*

CAUTION

Your instrument is calibrated to factory (default) settings when first supplied and must therefore be calibrated before use, to ensure optimum performance on your vessel. Do NOT use the instrument until the calibration procedures have been satisfactorily completed, using the procedures in Chapter 4, Calibration.

Coloured bezel and Desktop Mounting Bracket options are available for your ST40 instrument. Contact your Raymarine dealer for further information.

1.2 Operating procedures

Operating information is presented in flow chart form. The flow charts show the various operating screens and key presses necessary to carry out the various instrument functions. Key presses are momentary unless otherwise stated.

Note that:

- The maximum speed reading is reset to zero at power up.
- The average speed reading is reset to zero at power up.
- The Log screen shows the total distance covered by the vessel since the ST40 Speed instrument was fitted.
- The trip reading is reset to zero at power up.

NORMAL OPERATION

Switch on

The permanent screen selected at last switch off, is displayed.
(Current speed or Water temperature)

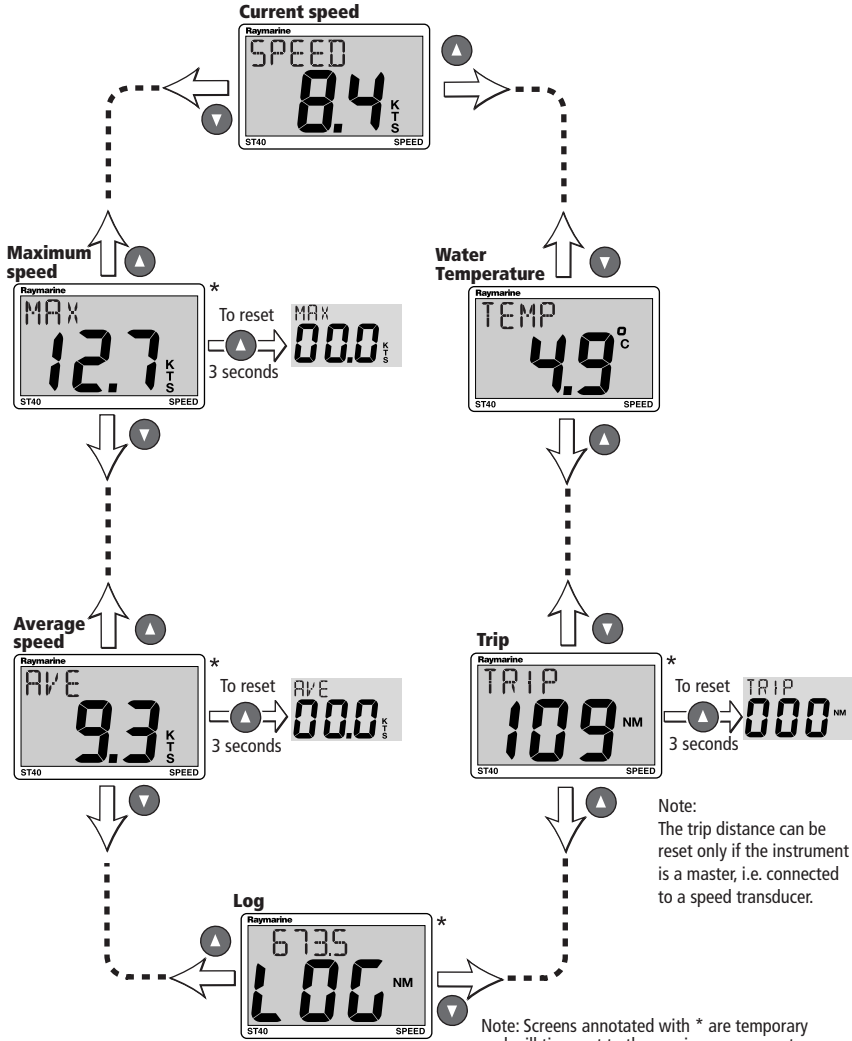

Note:
The trip distance can be reset only if the instrument is a master, i.e. connected to a speed transducer.

Note: Screens annotated with * are temporary and will time-out to the previous permanent screen **(Current speed or Water temperature)** after 5 seconds.

Adjusting display backlighting and contrast

Hold down  for 1 second to enter Adjust Backlight mode
for 2 seconds to move through Adjust Backlight mode and enter Adjust Contrast mode

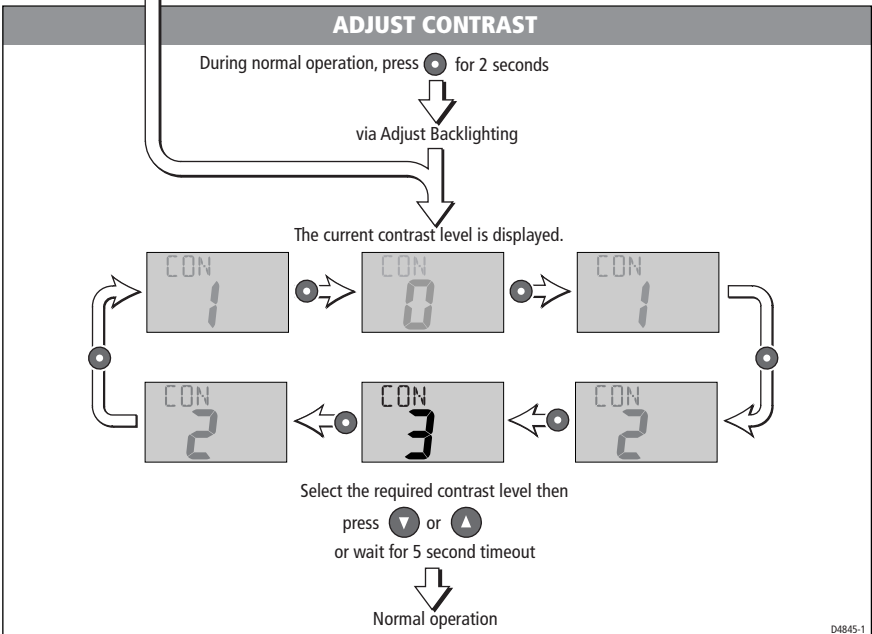
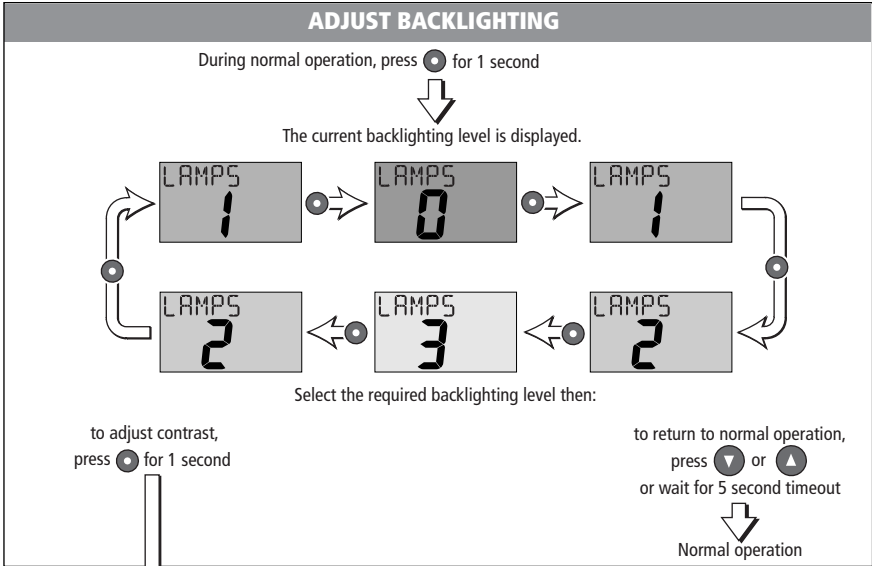

Chapter 2: Maintenance and Fault Finding

2.1 Maintenance

Servicing and safety

- Raymarine equipment should be serviced only by authorised Raymarine service technicians. They will ensure that service procedures and replacement parts used will not affect performance. There are no user-serviceable parts in any Raymarine product.
- Some products generate high voltages, so never handle the cables/connectors when power is being supplied to the equipment.
- When powered up, all electrical equipment produces electromagnetic fields. These can cause adjacent pieces of electrical equipment to interact with one another, with a consequent adverse affect on operation. In order to minimise these effects and enable you to get the best possible performance from your Raymarine equipment, guidelines are given in the installation instructions, to enable you to ensure minimum interaction between different items of equipment, i.e. ensure optimum Electromagnetic Compatibility (EMC).
- Always report any EMC-related problem to your nearest Raymarine dealer. We will use any such information to improve our quality standards.
- In some installations, it may not be possible to prevent the equipment from being affected by external influences. In general this will not damage the equipment but it can lead to spurious resetting action, or momentarily may result in faulty operation.
- Always switch off the power to Raymarine equipment before working on it.

When requesting service, please quote equipment Type, Model Number, Serial Number and, if possible, Software Release Issue. The Software Release Issue can be ascertained by means of the Intermediate Calibration facility, see *Chapter 4, Calibration*.

Instrument

Certain atmospheric conditions may cause a small amount of condensation to form on the instrument window. This will not harm the instrument and will clear after the instrument has been switched on for a short period.

Periodically clean your ST40 instrument with a soft damp cloth. Do NOT use chemical or abrasive materials to clean the instrument.

Transducer

Refer to the Installation and Maintenance instructions supplied with the transducer.

Cabling

Examine all cables for chafing or other damage to the outer shield and, where necessary, replace and re-secure.

2.2 Fault finding

Preliminary procedures

If you appear to have a problem, first check the security of the connections at the rear of the instrument and reconnect any that are loose.

Changes in the electronic environment may adversely affect the operation of your ST40 equipment. Typical examples of such changes are:

- Electrical equipment has recently been installed or moved aboard your vessel.
- You are in the vicinity of another vessel or shore station emitting radio signals.

Fixing faults

All Raymarine products are subjected to comprehensive test and quality assurance programmes prior to packing and shipping. However, if a fault occurs, the following guidelines may help to identify and rectify the problem.

Low battery

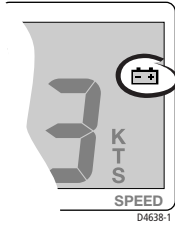

Action

Recharge your vessel's battery as soon as possible

Display blank

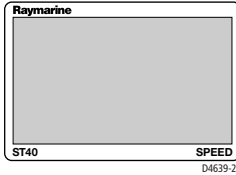

Action

Check fuse/circuit breaker.

Check power supply.

Check SeaTalk cabling and connector security.

No speed or water temperature information

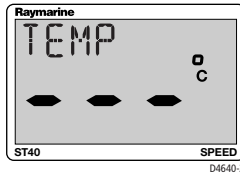
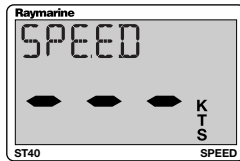

Action

Check the condition of the transducer cable and the security of the connections.

No speed information but water temperature information is present

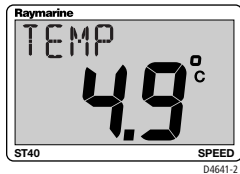
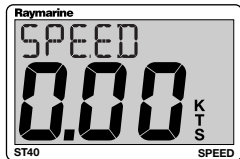

Action

Transducer paddle wheel may be fouled.

CAUTION

If you need to remove the transducer insert, have the transducer bung to hand and secure it in the transducer body immediately after the insert has been removed, to prevent excessive ingress of water.

Clean the paddle wheel.

SeaTalk information not being transferred between instruments

For example, backlighting level changes implemented at one instrument do not affect other instruments

Action

Check security of SeaTalk connections between instruments.

Check condition of SeaTalk cables.

Isolate faulty instrument by disconnecting instruments one by one.

A group of SeaTalk instruments not working

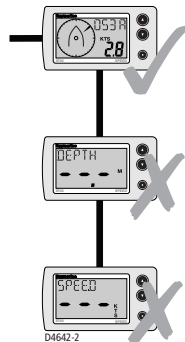

Action

Check the security of SeaTalk connectors between functioning and non-functioning instruments.

Assistance

If you are unable to rectify any problem, please contact your local Raymarine Dealer for assistance.

Chapter 3: Installation

This chapter describes how to install the ST40 Speed instrument, and associated speed transducer. The transducer is fitted in the hull of the vessel and is connected to the rear of the instrument.

3.1 Planning your installation

Determine the best positions for both transducer and instrument, such that the *EMC installation guidelines* and the *Site requirements* (below) are satisfied.

EMC installation guidelines

All Raymarine equipment and accessories are designed to the best industry standards for use in the leisure marine environment.

Their design and manufacture conform to the appropriate Electromagnetic Compatibility (EMC) standards, but correct installation is required to ensure that performance is not compromised. Although every effort has been taken to ensure that they will perform under all conditions, it is important to understand what factors could affect the operation of the product.

The guidelines given here describe the conditions for optimum EMC performance, but it is recognised that it may not be possible to meet all of these conditions in all situations. To ensure the best possible conditions for EMC performance within the constraints imposed by any location, always ensure the maximum separation possible between different items of electrical equipment.

For **optimum** EMC performance, it is recommended that **wherever possible**:

- All Raymarine equipment and cables connected to it are:
 - At least 1 m (3 feet) from any equipment transmitting or cables carrying radio signals e.g. VHF radios, cables and antennas. In the case of SSB radios, the distance should be increased to 2 m (7 ft).
 - More than 2 m (7 ft) from the path of a radar beam. A radar beam can normally be assumed to spread 20 degrees above and below the radiating element.

- The equipment is supplied from a different battery from that used for engine start. Voltage drops below 10 V in the power supply to our products, and starter motor transients, can cause the equipment to reset. This will not damage the equipment, but may cause the loss of some information and may change the operating mode.
- Raymarine specified cables are used at all times. Cutting and rejoining these cables can compromise EMC performance and so must be avoided unless doing so is detailed in the installation manual.
- If a suppression ferrite is attached to a cable, this ferrite should not be removed. If the ferrite needs to be removed during installation it must be reassembled in the same position.

Suppression Ferrites

The following illustration shows typical cable suppression ferrites fitted to Raymarine equipment. Always use the ferrites supplied by Raymarine.

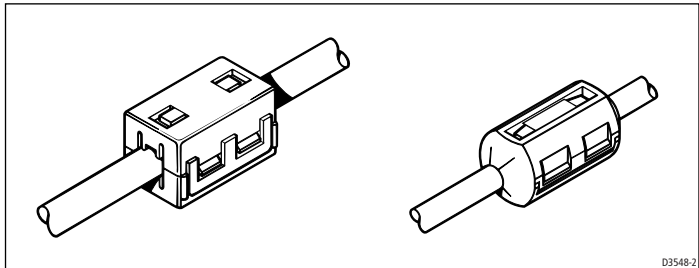

Connections to Other Equipment

If your Raymarine equipment is going to be connected to other equipment using a cable not supplied by Raymarine, a suppression ferrite **MUST** always be fitted to the cable close to the Raymarine unit.

Tools required

The tools required for fitting the standard ST40 instrument system are shown in the following illustration.

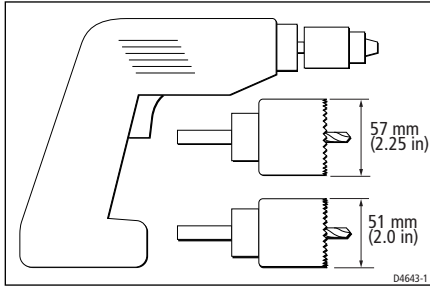

Note: *If you intend fitting a nonstandard transducer, extra tools may be required*

Site requirements

Transducer

The transducer types required for the various hull types are as follows:

Hull material	Transducer type
Glass reinforced plastic (GRP) Steel Aluminium	M78712 Through hull plastic (supplied as standard)
Wood	M78716 Through hull bronze

Other transducer types are also available for specific requirements. For further details, contact your local Raymarine dealer.

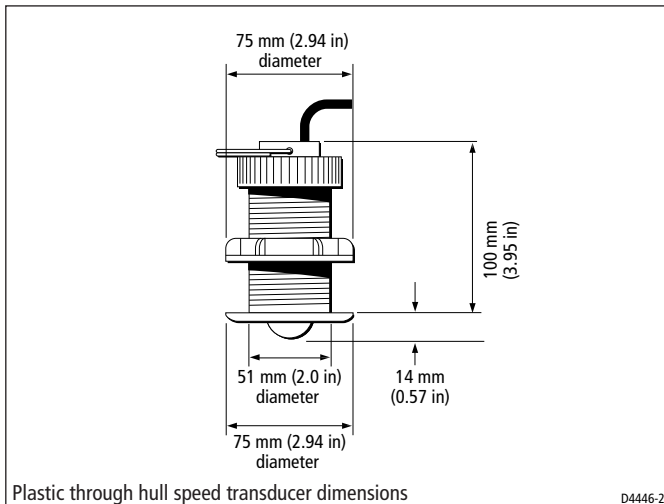

The transducer should:

- Be ahead of the propellers (by a minimum of 10% of the water line length).
- Be at least 150 mm (6 in) away from the keel (ideally ahead of the keel if a sailing yacht).
- Be as near as possible to the centre line of the vessel.
- Be clear of other through-hull fittings or projections.
- Have sufficient clearance inside the hull to fit the nut.
- Have 100 mm (4 in) of headroom to allow for withdrawal.

The transducer should be sited within the clear water flow areas indicated by the shaded areas in the following diagram.

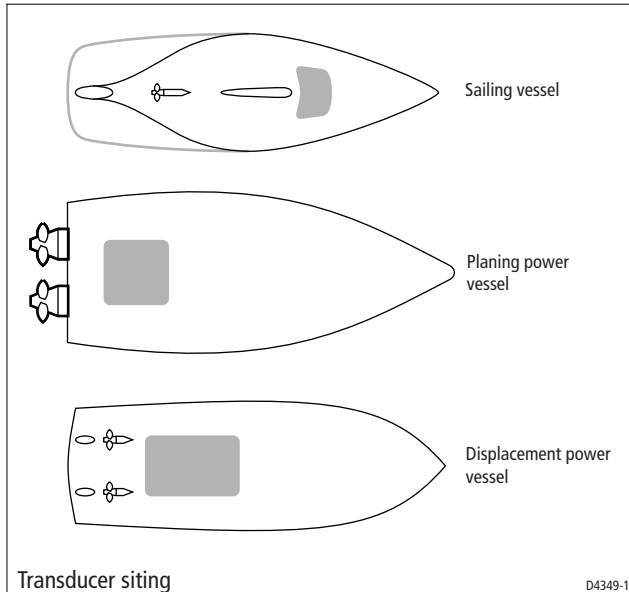

Instrument

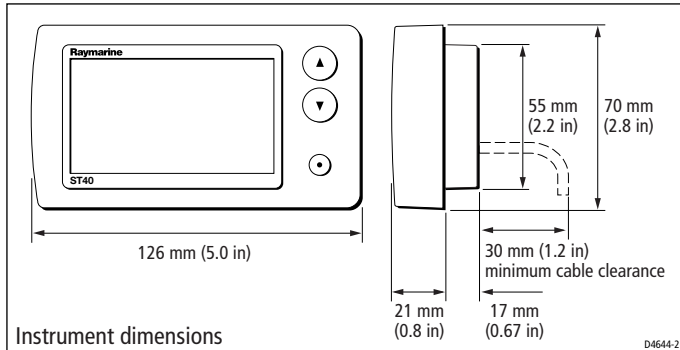

CAUTION:

The presence of moisture at the rear of the instrument could cause damage either by entering the instrument through the breathing hole or by coming into contact with the electrical connectors.

Each instrument must be positioned where:

- It is easily read by the helmsman or navigator
- It is protected against physical damage
- It is at least 230 mm (9 in) from a compass
- There is reasonable rear access for installation and servicing
- The rear of the instrument is protected from water.

3.2 Procedures

Adapt these procedures as appropriate, to suit your individual requirement.

CAUTION:

Where it is necessary to cut holes (e.g. for cable routing and instrument mounting), ensure that these will not cause a hazard by weakening critical parts of the vessel's structure. If in doubt, seek advice from a reputable boat builder.

Fitting transducer

Instructions for installing and maintaining the speed transducer are packed with it. Before attempting to install the transducer, read these instructions and the *Site requirements* for transducers described in this Chapter.

Running transducer cable

Each transducer has a 9 m (30 ft) cable fitted with spade terminals for connection to the ST40 Speed instrument. Observing the following guidelines, run the cable to the instrument:

- If the cable has to be fed through the deck, always use a good quality deck gland.
- Where cables are fed through holes, always use grommets to prevent chafing.
- Secure long cable runs so they do not present a hazard.
- Wherever possible, route the cable away from fluorescent lights, engines, radio transmitting equipment, as these may cause interference.

Connections to the instrument

You can connect your instrument:

- Directly to the speed transducer as a stand-alone master instrument. When connected in this manner, the instrument must be connected to a suitable power source using the 1 m (3 ft) power cable provided.
- As part of a SeaTalk system either as a repeater or, with a transducer also connected as a system master. To connect to SeaTalk, you will need an additional SeaTalk Interconnection Kit, (Part No. E25028). When connected in this manner, power can be provided from the SeaTalk bus (e.g. from the autopilot).

You can also connect the instrument to both the speed transducer and SeaTalk. When thus connected, the instrument will be the master speed instrument for the SeaTalk system.

If it is necessary to fit spade connectors to the transducer cable, do so as shown in the following illustration. Prepare the cable, as at (a), and fit the spade connectors, as at (b). When fitting each spade connector, ensure that wire strands do not extend beyond the rear of the spade connector insulation.

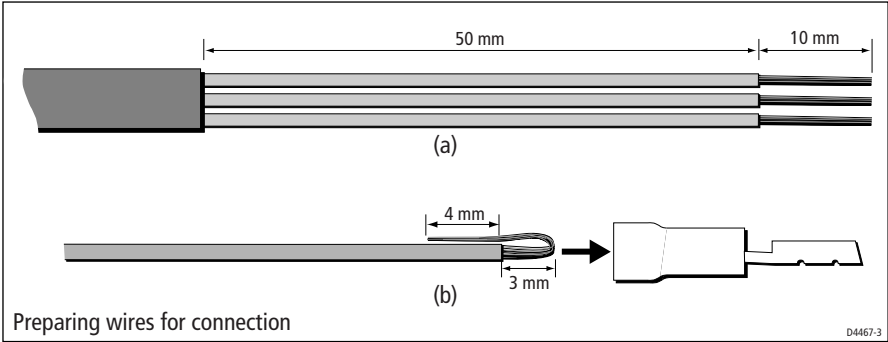

Stand-alone connections

CAUTION

Ensure that the power supply for each stand-alone ST40 instrument is protected by a 3 A fuse or circuit breaker.

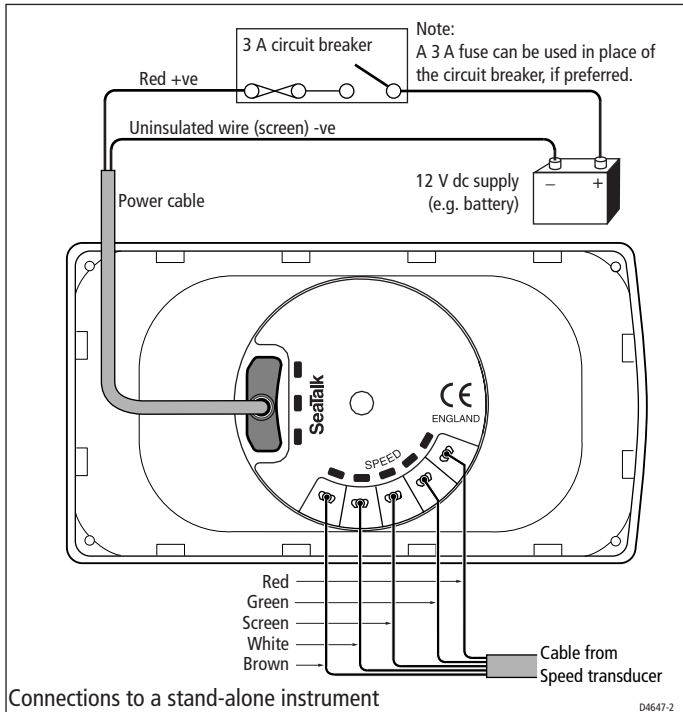

SeaTalk connections

CAUTION

When instruments are connected to SeaTalk, ensure that the power supply for the SeaTalk 12 V line is protected by a 5 A fuse or circuit breaker.

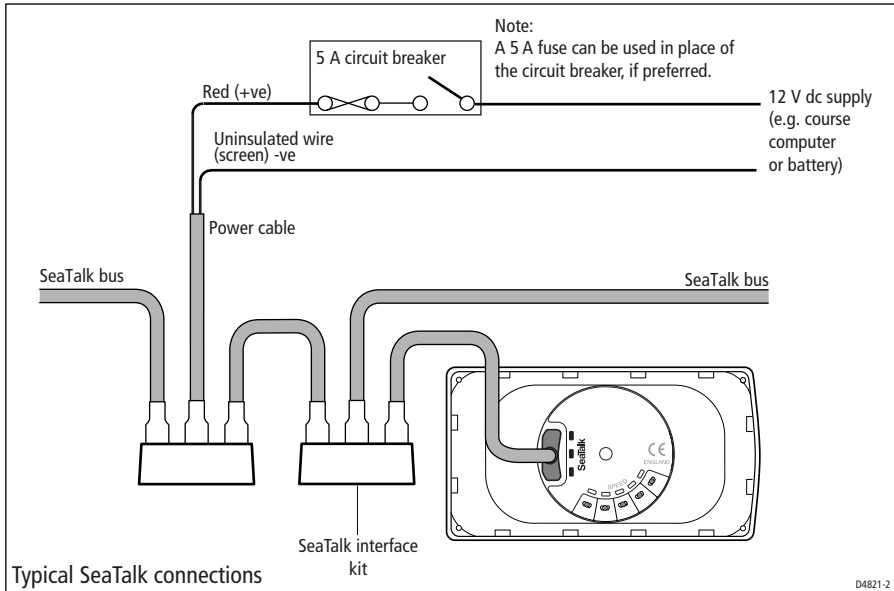

Fitting the instrument

Fit your ST40 instrument as shown in the following illustrations.

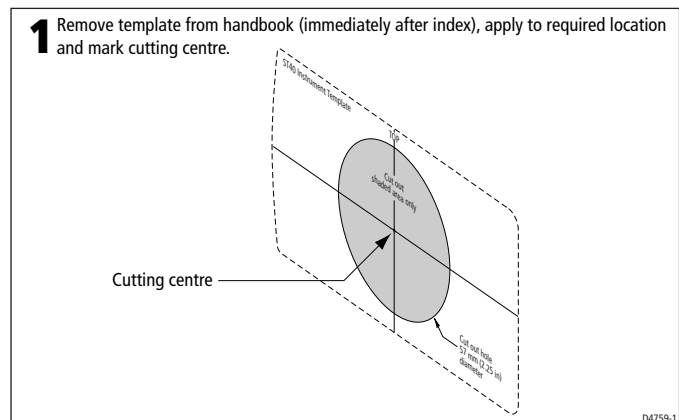

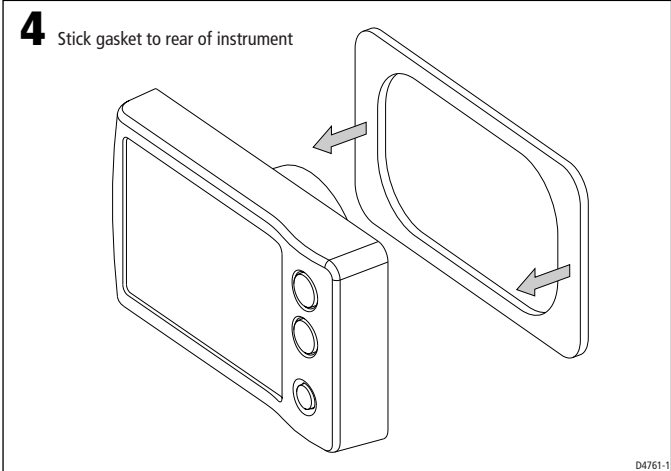
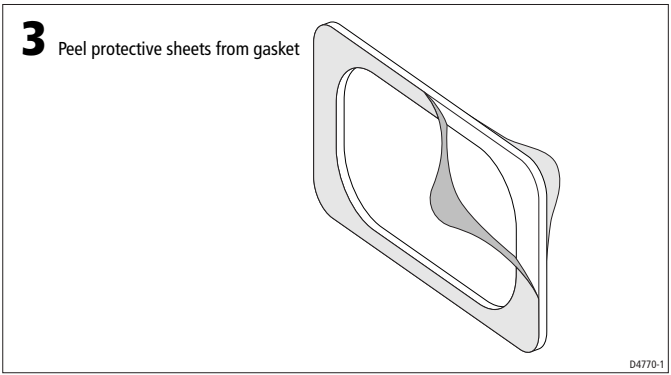
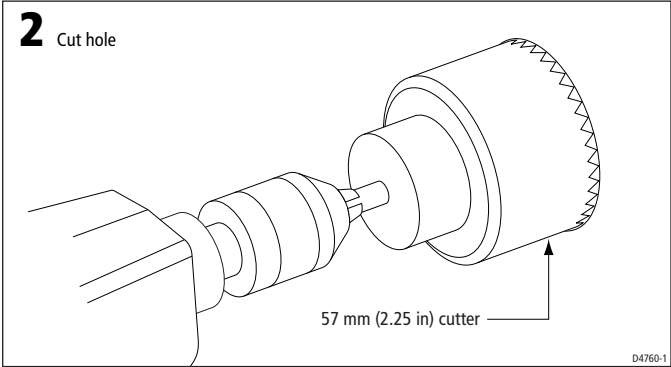

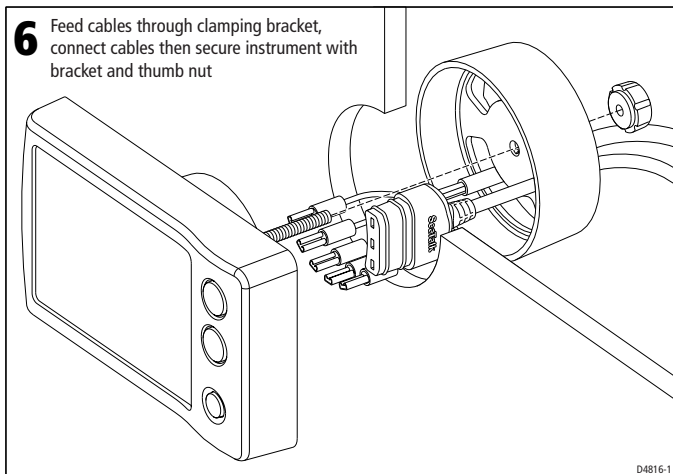
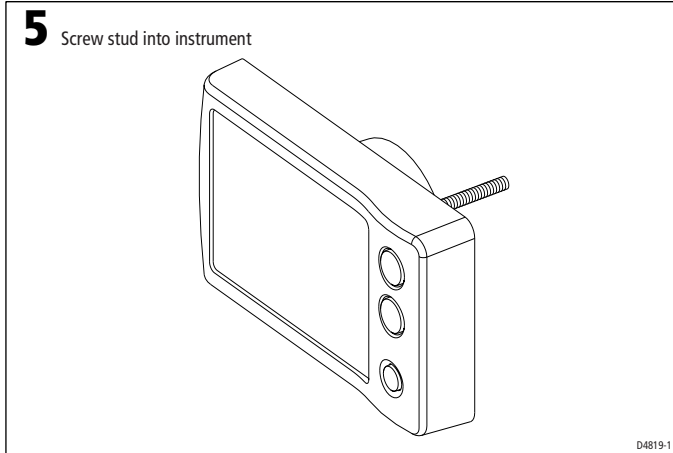

Desktop Mounting Bracket

An optional Desktop Mounting Bracket (Part No. E25024) enables you to mount your ST40 instrument in locations where other forms of mounting are impractical.

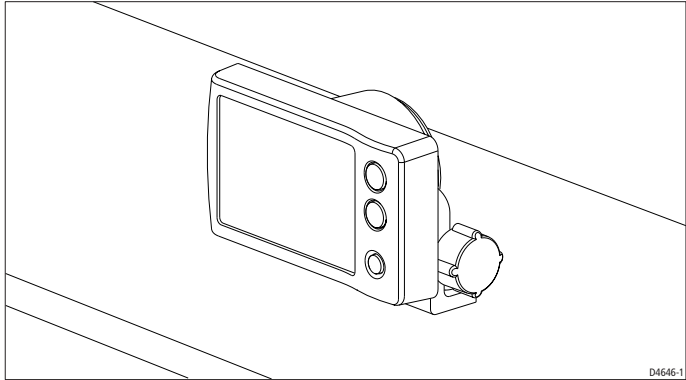

To bracket mount your ST40 instrument, do so in accordance with the *Instruction Sheet*, which is included with the Desktop Mounting Bracket.

3.3 Calibration requirement

Once installation is complete and before you use your instrument, carry out the calibration procedures detailed in *Chapter 4, Calibration*.

Chapter 4: Calibration

4.1 Introduction

The procedures in this Chapter must be carried out before the equipment is used operationally, to optimise the performance of the instrument with the vessel.

Calibration information is presented in flow chart form. The flow charts show the various calibration screens and key presses necessary to carry out calibration. All key presses are momentary unless otherwise stated.

EMC conformance

Always check the installation before going to sea to make sure that it is not affected by radio transmissions, engine starting etc.

4.2 User calibration

User calibration enables you to:

- Set the required units for speed readings. Either KTS (knots), MPH (miles per hour) or KPH (kilometres per hour).
- Set the required distance units. Either NM (nautical miles), SM (statute miles) or KM (kilometres).
- Select water temperature units. Either °C or °F, as required.
- Set the speed display response. Use higher response values when boating in conditions requiring rapid updates of the current speed (e.g. competition sailing or on power boats). Use slower response values when you require an average speed over a longer period of time (e.g. when cruising, especially in heavy seas).
- Set the correct speed reading, either by using a **Cal factor** screen to adjust the calibration factor, or by applying Speed Over Ground (SOG) as the current speed. Your vessel must be moving at 0.5 KTS or more and be receiving SeaTalk SOG data, to enable SOG to be applied as the current speed. This should be done only in conditions of zero tide and current.

To carry out User calibration, power up the instrument then follow the procedure in the *User calibration* flow diagram.

USER CALIBRATION

During normal operation
hold down and for approximately 2 seconds

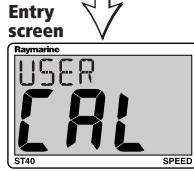

Note:
If there is no key activity when the **Entry screen** is displayed, calibration will time out to normal operation after 5 seconds,

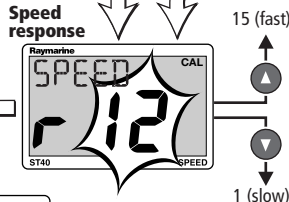

Speed units

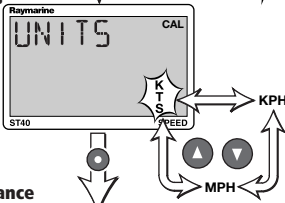

Distance units

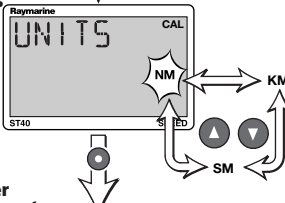

Water temperature units

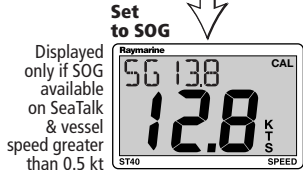
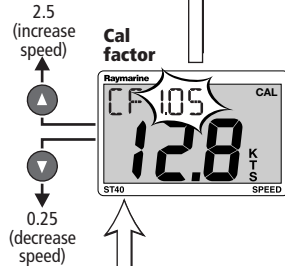
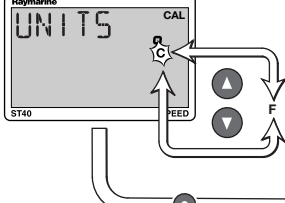

To apply SOG value as speed reading, press for 3 seconds, in conditions of zero tide and current

Note:
Screens other than the **Entry screen** and the **Speed response** screen are available only on master instruments.

To save your settings and return to normal operation from any screen,
hold down and for approximately 2 seconds

4.3 Intermediate calibration

Intermediate calibration enables you to:

- Check the instrument software version.
- Check and if necessary set, the instrument status - either MASTR (master) or REPTR (repeater).

Follow the procedure in the *Intermediate calibration* flow diagram.

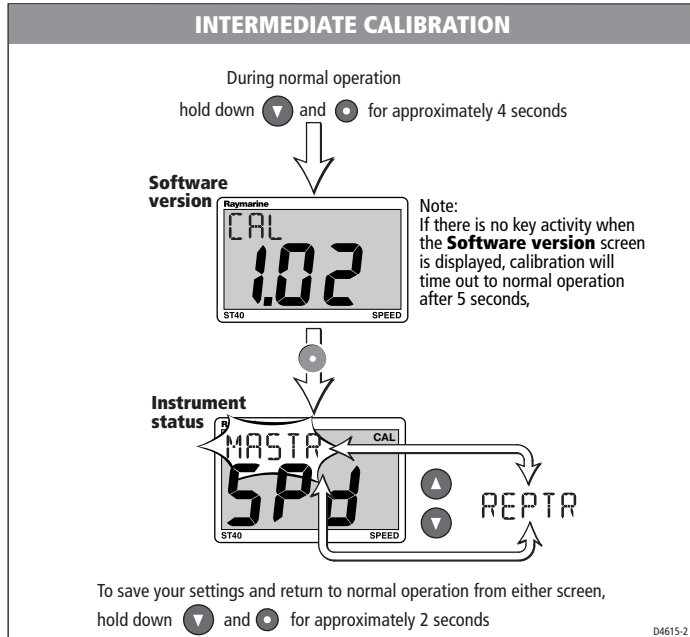

4.4 Dealer calibration



Dealer calibration enables you to set:

- User calibration on/off.
- Boat show mode on/off.

Dealer calibration also gives access to the **Factory defaults** screen. This enables you to reapply the factory settings if you want to reset the instrument to a known operating condition.

Follow the procedure in the *Dealer calibration* flow diagram.

DEALER CALIBRATION

During normal operation
hold down  and  for approximately 12 seconds

Entry screen

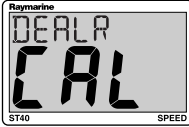

Note:
If there is no key activity when the **Entry screen** is displayed, calibration will time out to normal operation after 5 seconds,

Calibration access

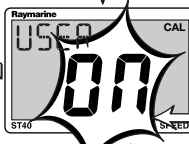

If **NO**
If **YES** →

Return to normal operation with factory defaults set



Boat show mode

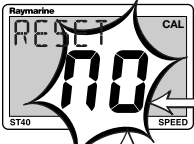

CAUTION:
Do NOT switch the Boat Show mode on.
This function must only be used for demonstration purposes.

Factory defaults



To save your settings and return to normal operation from any screen,
hold down  and  for approximately 2 seconds

Instrument Specification

Supply voltage:	10 V to 16 V dc.
Current consumption (12 V supply):	25 mA typical. 60 mA with maximum backlighting.
Operating temperature:	0°C to +70°C.
Interfaces:	SeaTalk.
Overall dimensions:	126 mm x 70 mm x 38 mm (5.00 inches x 2.80 inches x 1.55 inches).
Boss diameter:	55 mm (2.20 inches).
Speed range:	0 to 99.9 knots.
Log range:	0 to 99999.
Trip range:	0 to 999 nautical miles.
Water temperature reading range:	-10°C to +40°C.
Approvals:	
CE - conforms to	89/336/EC(EMC), EN60945. 94/25/EC(RCD), EN28846 (applies to transducer only).

Glossary

- Cal factor** Calibration factor. Used in ST40 Speed and Bidata instruments to ensure the current speed reading is the actual speed. Values are from 0.25 (reduce speed reading) to 2.5 (increase speed reading).
- EMC** Electromagnetic Compatibility.
- KPH** Kilometres Per Hour.
- KTS** Knots.
- MPH** Miles Per Hour.
- NM** Nautical Miles.
- Response** Determines the rate at which an instrument responds to changes in boat speed. Values are from 1 (slow response) to 15 (fast response).
- SeaTalk** SeaTalk is a proprietary Raymarine system which links different compatible products, to provide a single, integrated navigational system. SeaTalk can also communicate with non-SeaTalk equipment using the internationally- accepted National Marine Electronics Association (NMEA) protocol. Contact your Raymarine dealer for details.

Index

A

Average speed reset 2

B

Backlighting 3

Boat show mode 23

C

Calibration 21–24

Dealer 23–24

Intermediate 23

setting appropriate response values 21–24

setting user access 24

User 21–22

Calibration requirement 1, 19

Cleaning the instrument 6

Condensation 6

Connecting the instrument 14–16

Contrast 3

Current consumption 25

D

Dealer calibration 23–24

Desktop Mounting Bracket 18–19

Dimensions 25

Display

backlighting 3

contrast 3

E

EMC

conformance i, 21

installation guidelines 9–10

F

Factory defaults

setting 23

Fault finding 6

assistance 8

blank display 7

low battery 7

no speed information 7

no speed or water temperature information 7

SeaTalk problems 8

I

Installation 9–19

connecting the instrument 14–16

EMC guidelines 9–10

fitting the instrument 16–19

planning 9–13

procedures 13–19

site requirements 11–13

tools required 10–11

transducer 14

Instrument

cleaning 6

condensation 6

connecting 14–16

current consumption 25

dimensions 25

fitting 16–19

site requirements 13

status (master or repeater) 23

supply voltage 25

Intermediate calibration 23

L

Log distance 1

range 25

M

Maintenance 5–6

Maximum speed 1

Maximum speed reset 2

N

Normal operation 2–3

O

Operating procedures 1–3

Operating temperature 25

P

Panel lighting 3

Parts supplied vi

R

Reset

average speed 2

maximum speed 2

trip distance 2

S

Servicing and safety 5

Setting

backlighting 3

calibration factor 22

contrast 3

correct speed 22

speed response 22

speed to SOG 22

speed units 22

water temperature units 22

Site requirements 11–13

instrument 13

transducer 11–12

Software version 23

Specifications 25

Speed

appropriate response values 21

average 1

calibration factor 27

current 1

maximum 1

range 25

response 27

setting response 22

setting units 22

T

Transducer

fitting 14

site requirements 11–12

Trip distance 1

Trip distance reset 2

Trip range 25

U

User calibration 21–22

V

Voltage 25

W

Water temperature 1

range 25

setting units 22

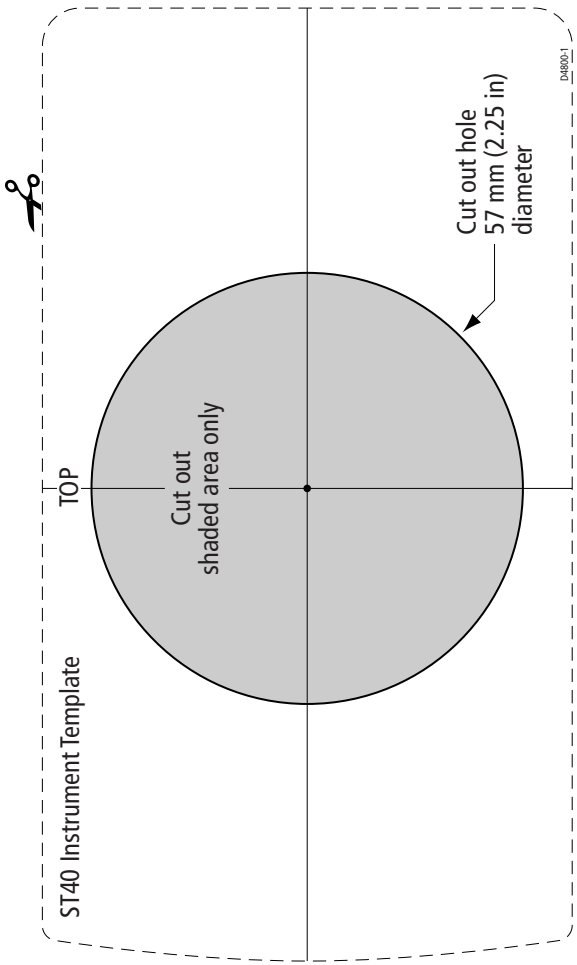

Limited Warranty Certificate

Raymarine warrants each new Light Marine/Dealer Distributor Product to be of good materials and workmanship, and will repair or exchange any parts proven to be defective in material and workmanship under normal use for a period of 2 years/24 months from date of sale to end user, except as provided below.

Defects will be corrected by Raymarine or an authorized Raymarine dealer. Raymarine will, except as provided below, accept labor cost for a period of 2 years/24 months from the date of sale to end user. During this period, except for certain products, travel costs (auto mileage and tolls) up to 100 round trip highway miles (160 kilometres) and travel time of 2 hours, will be assumed by Raymarine only on products where proof of installation or commission by authorized service agents, can be shown.

Warranty Limitations

Raymarine Warranty policy does not apply to equipment which has been subjected to accident, abuse or misuse, shipping damage, alterations, corrosion, incorrect and/or non-authorized service, or equipment on which the serial number has been altered, mutilated or removed.

Except where Raymarine or its authorized dealer has performed the installation, it assumes no responsibility for damage incurred during installation.

This Warranty does not cover routine system checkouts or alignment/calibration, unless required by replacement of part(s) in the area being aligned.

A suitable proof of purchase, showing date, place, and serial number must be made available to Raymarine or authorized service agent at the time of request for Warranty service.

Consumable items, (such as: Chart paper, lamps, fuses, batteries, styli, stylus/drive belts, radar mixer crystals/diodes, snap-in impeller carriers, impellers, impeller bearings, and impeller shaft) are specifically excluded from this Warranty.

Magnetrons, Cathode Ray Tubes (CRT), TFT Liquid Crystal Displays (LCD) and cold cathode fluorescent lamps (CCFL), hailer horns and transducers are warranted for 1 year/12 months from date of sale. These items must be returned to a Raymarine facility.

All costs associated with transducer replacement, other than the cost of the transducer itself, are specifically excluded from this Warranty.

Overtime premium labor portion of services outside of normal working hours is not covered by this Warranty.

Travel cost allowance on certain products with a suggested retail price below \$2500.00 is not authorized. When/or if repairs are necessary, these products must be forwarded to a Raymarine facility or an authorized dealer at owner's expense will be returned via surface carrier at no cost to the owner.

Travel costs other than auto mileage, tolls and two (2) hours travel time, are specifically excluded on all products. Travel costs which are excluded from the coverage of this Warranty include but are not limited to: taxi, launch fees, aircraft rental, subsistence, customs, shipping and communication charges etc. Travel costs, mileage and time, in excess to that allowed must have prior approval in writing.

TO THE EXTENT CONSISTENT WITH STATE AND FEDERAL LAW:

(1) THIS WARRANTY IS STRICTLY LIMITED TO THE TERMS INDICATED HEREIN, AND NO OTHER WARRANTIES OR REMEDIES SHALL BE BINDING ON RAYMARINE INCLUDING WITHOUT LIMITATION ANY WARRANTIES OF MERCHANTABILITY OR FITNESS FOR A PARTICULAR PURPOSE.

(2) Raymarine shall not be liable for any incidental, consequential or special (including punitive or multiple) damages.

All Raymarine products sold or provided hereunder are merely aids to navigation. It is the responsibility of the user to exercise discretion and proper navigational skill independent of any Raymarine equipment.

Raymarine

Factory Service Centers

United States of America

Raymarine Inc
22 Cotton Road, Unit D
Nashua, NH 03063-4219, USA

Telephone: +1 603 881 5200
Fax: +1 603 864 4756
www.raymarine.com

Sales & Order Services

Telephone: +1 800 539 5539 Ext. 2333 or
+1 603 881 5200 Ext. 2333

Technical Support

Telephone: +1 800 539 5539 Ext. 2444 or
+1 603 881 5200 Ext. 2444
Email: techsupport@raymarine.com

Product Repair Center

Telephone: +1 800 539 5539 Ext. 2118

UK, Europe, Middle East, Far East

Raymarine Ltd
Anchorage Park, Portsmouth
PO3 5TD, England

Telephone: +44 (0)23 9269 3611
Fax: +44 (0)23 9269 4642
www.raymarine.com

Customer Support

Telephone: +44 (0)23 9271 4713
Fax: +44 (0)23 9266 1228

Email: techsupport@raymarine.com

Stick barcode label here

Purchased from

Purchase date

Dealer address

Installed by

Installation date

Commissioned by

Commissioning date

Owner's name

Mailing address

This portion should be completed and retained by the owner.