

MANUAL

# **Simrad AI50**

Class B Transceiver

988-0168-001 May07 English



**MANUAL**

**Simrad AI50**

Class B Transceiver

988-0168-002 Iss.2.0 English

**© 2007 Navico**

The technical data, information and illustrations contained in this publication were to the best of our knowledge correct at the time of going to print. We reserve the right to change specifications, equipment, installation and maintenance instructions without notice as part of our policy of continuous development and improvement.

No part of this publication may be reproduced, stored in a retrieval system or transmitted in any form, electronic or otherwise, without prior permission from Simrad Ltd.

No liability can be accepted for any inaccuracies or omissions in the publication, although every care has been taken to make it as complete and accurate as possible.

988-0168-001 Iss.2.0 May 07 WP

[www.Busse-Yachtshop.de](http://www.Busse-Yachtshop.de)

email: [info@busse-yachtshop.de](mailto:info@busse-yachtshop.de)

# AIS50 CLASS B TRANCEIVER

## CONTENTS

### 1 INTRODUCTION

1.1 General Overview	9
1.2 About this manual	10
1.3 SimNet/NMEA2000 Network System	10

### 2 INSTALLATION

2.1 General	11
2.2 Panel Mounting	11
2.3 Bracket Mounting	12
2.4 GPS Antenna	12
2.5 VHF Antenna	13
2.6 Power/Data Cable	15
2.7 SimNet Cable	15
2.8 SD card (Not supplied)	16

### 3 KEYPAD OVERVIEW

3.1 Layout	17
3.2 PWR/Lights key (Powering on and off)	17
3.3 Navigation Keys	18
3.3.1 Display Mode	18
3.3.2 Menu Mode	18
3.3.3 Data Entry Mode	18
3.4 Zoom Keys	18
3.5 ENTER/MENU	18
3.6 INFO/STATUS	19
3.7 TRACK/CLR TRK	19
3.8 HOME/DSC	19
3.9 VIEW/DISPLAY	19
3.10 PWR/☀ (Backlight adjustment)	19

### 4 INITIAL CONFIGURATION

4.1 Window Display convention	21
4.2 Initial Start Up Sequence	21
4.3 Ship Configuration Procedure	23
4.3.1 MMSI Entry	23
4.3.2 Vessel Type Entry	25
4.3.3 Vessel Dimensions & GPS Reference	26

4.3.4 Call Sign Entry	27
4.3.5 Vessel Name Entry	28

## 5 MENU MODE

5.1 General	29
5.2 Display Mode settings	29
5.2.1 Coastline Detail	29
5.2.2 Tracking Offset	30
5.2.3 Display Offset	30
5.2.4 Show Range Rings	31
5.3 Display Settings	31
5.3.1 Display Brightness	31
5.3.2 Keypad Brightness	32
5.3.3 Keypad Colour	32
5.3.4 Display Palette	32
5.4 Favourites List	33
5.4.1 Add an Entry	33
5.4.2 Edit an Entry	34
5.4.3 Delete an Entry	35
5.5 Alarm Setup	35
5.5.1 Collision Alarm	36
5.5.1.1 CPA/TCPA	36
5.5.1.2 Guard Zone	37
5.5.2 Lost Vessel Alarm	38
5.5.3 Favourites Alarm	39
5.6 System Setup	40
5.6.1 Units of Measure	40
5.6.2 Set Local Time	41
5.6.3 Ship Configuration	41
5.6.4 Key Beeps	42
5.6.5 Set Language	42
5.6.6 Data Logging	42
5.6.6.1 Enabling	43
5.6.6.2 Disabling	44
5.6.6.3 Playback Log	44
5.6.7 Transmit Enable	45
5.6.8 Reset Options	45
5.7 SimNet/NMEA2000	45
5.7.1 Data Sources	46
5.7.2 Network Management	46

---

5.7.2.1 Device Instance	46
5.7.2.2 System Instance	47
5.7.3 Network List	47
5.7.4 Remote Enable	48
5.7.4 DSC Radio Select	48
5.8 Product Info	48

## **6 AIS MAP MODE**

6.1 General	51
6.2 Vessel Icon Detail	51
6.3 Range Rings/ Range Info	51
6.4 Point Of View	52
6.5 Coast Line Detail	54
6.6 Cursor	54
6.7 Transmit Legend	54
6.8 Vessel Information	55
6.8.1 Own Vessel	55
6.8.2 Other Vessel's Info (Reduced list)	55
6.8.3 Other Vessel (Full list)	56
6.8.4 Other Vessel (Minimal list)	56
6.9 General Rules for Vessel Information	57
6.10 Making a DSC Call (in map mode)	57
6.11 Text Mode	58
6.11.1 Changing the Sort Order	59
6.12 Making a DSC Call (in text mode)	59
6.13 Tracking Individual Vessels	59
6.14 Tracking your own Vessel	60
6.15 Clearing Down All Trails	60
6.16 Light Adjustment (Short Cut)	61

## **7 ALARMS**

7.1 General	63
7.2 Collision Alarm – CPA/TCPA	64
7.3 Collision Alarm – Lost Vessel	65
7.4 Collision Alarm – Guard Zone	66
7.5 BIIT Alarm	66
7.6 Lost Vessel Alarm	67
7.7 Favourites Alarm	67
7.8 Loss Of Compass Heading Data	68
7.9 Safety Message Alarm	69

## **8 APPENDIX**

8.1 Maintenance	71
8.2 Troubleshooting	71
8.3 Accessories	72
8.4 Product Specifications	72
8.5 Dimensions	74
8.6 Service and Warranty	74
8.7 Declaration of Conformity (EU)	75

# 1 INTRODUCTION

## 1.1 General Overview

Simrad's AI50 is an Automatic Identification System (AIS). It is an autonomous and continuous information reporting system, operating in the VHF maritime mobile band. It allows AIS equipped vessels to automatically and dynamically exchange and display information with similarly equipped vessels and shore based traffic stations. Fig. 1.1



*Fig. 1.1 - AI50 Class B Transceiver*

The AI50 uses a sophisticated automatic digital time sharing technology which allows a large number of similarly equipped vessels within VHF range of each other, to time share the same radio channel without interference. This enables the automatic exchange of static information like; MMSI (Maritime Mobile Service Identifier) Number, Vessel's Name, Call Sign and Type. Also dynamic data like; Position, Course, Distance and more, from ship to ship, and from ship to shore based traffic stations.

The advantages of the AI50 are:

- Increased awareness of the current shipping situation within your VHF range through the exchange of data between vessels.
- Improving traffic management in busy shipping lanes through exchanging information between vessels and shore based traffic stations.

- Reporting information automatically in shipping areas where it is mandatory.

## **WARNING**

***As with all electronic navigational equipment, it is only an aid to navigation and should not be used as a substitute for good seamanship. Remember - Maritime law requires that you keep a good lookout at all times.***

***The position of a vessel on the screen is the position of the most recent transmission and may not be the current position.***

## **1.2 About this manual**

The manual combines operating and installation information for the AI50. Operation is sub-divided into main working categories for easy reference.

## **1.3 SimNet/NMEA2000 Network System**

SimNet is Simrad's proprietary high speed data bus network complete with NMEA2000. It provides intelligent sharing of data and control information between a wide range of marine electronics and instruments.

## 2 INSTALLATION

### 2.1 General

The AI50 can be flush mounted or bracket mounted, however, to determine the best possible location for good navigation, you need to consider these few options:

- For ease of use - keep it within easy reach
- For good screen visibility - keep away from direct sunlight if possible
- Ensure good ventilation
- Decide how and where, you are going to run the cabling from the rear of the unit.

The AI50 is very simple to install, however, the performance of the equipment is directly affected by the quality of the installation. Please read these instructions carefully before attempting installation. If in any doubt, consult a qualified marine electronics engineer.

### 2.2 Panel Mounting

The transceiver requires a flat surface with an area of at least 172mm x 115mm (6.8in x 4.5in) for mounting Fig 2.1.

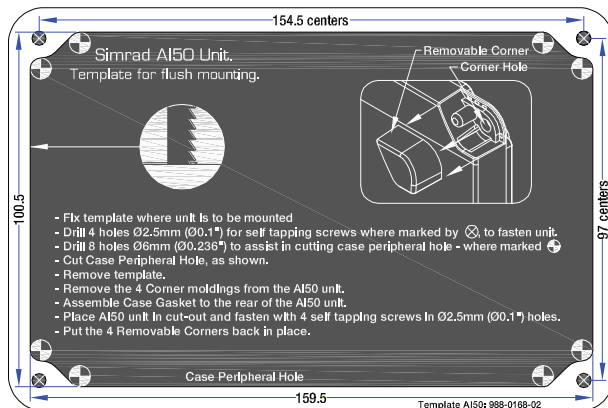

*Fig. 2.1 – Panel Cut-out drawing*

Allow sufficient space behind the unit for cable entry – at least 50mm (2.0in), in addition to the depth of the unit, is recommended. The surface should be rigid and sturdy enough to be able to support the weight of the

unit, taking into account the shock loads likely to be encountered when the vessel is under way in heavy seas.

1. Remove the backing paper and stick the cutting template onto your console or panel where the unit is to be mounted.
2. Drill a 2.5mm hole in each corner, where shown, to fasten the unit.
3. Drill 8 x 6mm holes where shown to assist in cutting the case peripheral hole.
4. Carefully cut the hole where shown on the template.
5. Remove the template.
6. Assemble case gasket to the rear of the AI50 unit.
7. Place the AI50 unit in the cut-out and fasten with 4 self tapping screws into 2.5mm holes.
8. Carefully remove 4 corners, (3 left and 3 right supplied, ), from the moulding rosette. (*Note: they are numbered 1 and 2 on rear*)
9. Place the 4 snap fit, removable corner covers into place. (No. 1 is placed in the bottom left and top right position, No. 2 is placed in the top left and bottom right position.

### 2.3 Bracket Mounting

Using the supplied bracket as a template, hold it against the surface it is going to be mounted on. With a marker pen, make a mark through the centre of the holes and drill a 3.5mm pilot hole on each mark. Secure to the surface with the supplied self tapping screws.

### 2.4 GPS Antenna

The antenna, ideally needs to be mounted as low as possible with a clear view of the sky to minimise errors due to movement over and above the transitory movement of the vessel. It can either be deck mounted, or mounted onto a rail. Use only the cable supplied with the antenna to connect it to the AI50.

**Note** *DO NOT connect your antenna using further extension cables as this may degrade the reception to a point where it may not function correctly.*

To minimize interference, place the antenna in a position away from steel constructions, wires, metal masts, sources of electrical interference, such as radar etc. If installing the GPS antenna close to other antennas, mount it either above or below their radiation beams.

The antenna cable is terminated in a push fit connector (SMB). Push the antenna plug firmly into the socket on the back of the AI50.

For a guide to the connections on the AI50 see Fig. 2.2

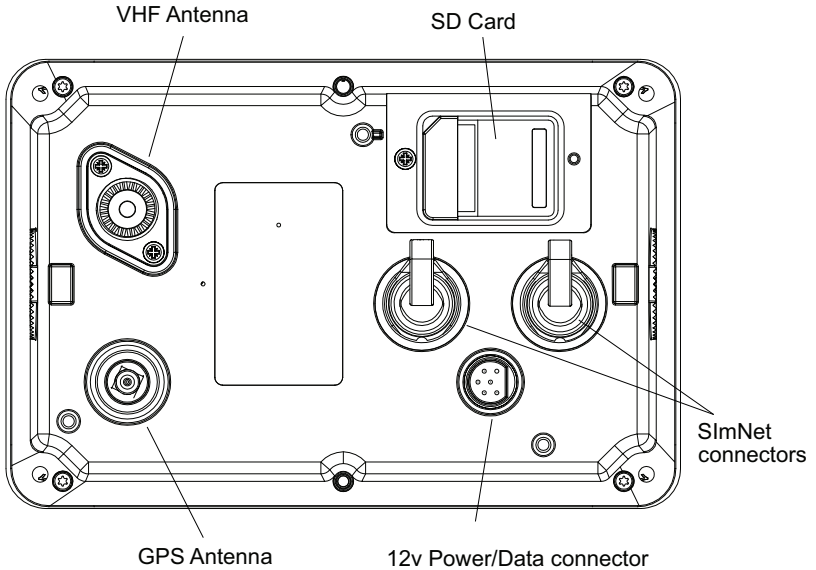

Fig. 2.2 - Rear view connections

## 2.5 VHF Antenna

**Note** *North American Users - To meet FCC (Federal Communications Commission) rules on Radio Frequency Exposure, it is recommended that the VHF antenna is mounted at least 3m (10ft) away from any area accessible to any personnel on board. If this distance is achieved by vertical separation, the antenna must be at least 5m (16.5ft) above deck. This guideline applies only to antennas not exceeding 3dBi gain.*

### **WARNING**

**Failure to observe these recommendations may expose those within the MPE (Maximum Permitted Exposure) radius of 3m (10ft) to RF absorption levels that exceed the FCC safe limits.**

The most important factor in the performance of any AIS transceiver will be the quality and positioning of the antenna.

As the range of VHF signals are governed by line of sight, the antenna should be placed as high as possible, while remaining clear of any metallic objects. Long whip antennae are generally recommended for larger boats, although the most popular antennae for marine use is 1m (3ft 3in) long. On sailboats these are usually mounted on the masthead, where the length of the antenna keeps it clear from the navigation lights and wind vanes. This type of antenna can also be mounted on the cockpit roof or powerboat garages.

For maximum range, it is recommended that a VHF antenna specifically tuned for use with an AIS is used, and mounted away from the standard VHF antenna. Vertical separation is preferred, but where this is not practical, at least 5 metre horizontal spacing is recommended

### **WARNING**

***The antenna coaxial cable and any connectors used must be rated at 50Ω. Under no circumstances should standard domestic TV cable and connectors be used. Incorrectly rated cabling and connectors could result in power not reaching the antenna, but also power could be reflected back into the AI50 unit, damaging it in the process.***

The quality of any connections and integrity of the cable will directly affect the performance of the radio. Poor soldering or corrosion of the terminals can impair performance. We recommend that screw or crimp terminal type connectors are not used for any through deck fittings - a good quality waterproof solder terminal connector will be less susceptible to poor connection due to corrosion of the contacts.

To ensure the best performance of the radio, the antenna cable should be routed where it is least likely to interfere with, or receive interference from other electronic equipment, such as echo sounder transducer cables and high current carrying cables.

The antenna cable should terminate in a standard marine PL259 plug fitting. Connect the antenna plug to the socket on the back of the AI50 and screw the retaining collar down Fig. 2.3.

**Note** *To avoid possible water damage to the transceiver, it is recommended that all cables are looped to provide a drip path.*

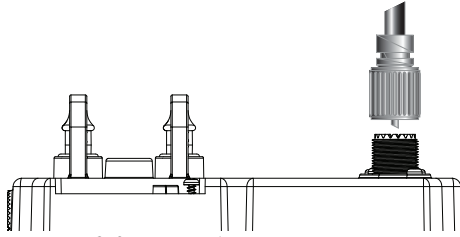

*Fig 2.3 - VHF Antenna connection*

## 2.6 Power/Data Cable

**Power cable** - The electrical installation is quite straightforward - push the connector end of the supplied Power/Data cable firmly into the socket on the rear of the unit. The Power cable has two wires, one red and one black. Connect the red cable to +12V via a 2Amp fuse, and the black cable to 0V.

**Data cable** - The data cable is used for connectivity to AIS enabled chart plotters with NMEA0183 interface. The Data cable is screened and has four wires. For connection data refer to the following table Fig.2.4.

Signal	Colour	Comment
Out +ve	Orange	
Out -ve	Blue	
In +ve	Yellow	Not Used
In -ve	Green	Not Used
0v	Screen	

*Fig. 2.4 - NMEA0183 connections*

## 2.7 SimNet Cable

The AI50 is connected to the SimNet databus using the cable supplied. Ensure that the connector on the end of the cable is in the correct orientation and press firmly into either of the two sockets on the rear of the unit. Fig.2.2.

The spare socket can be used to daisy chain SimNet to another item of equipment. If the spare socket is not used insert the supplied blanking plug.

## 2.8 SD card (Not supplied)

The SD card slot is situated on the reverse of the unit under a water resistant cover, Fig. 2.5.

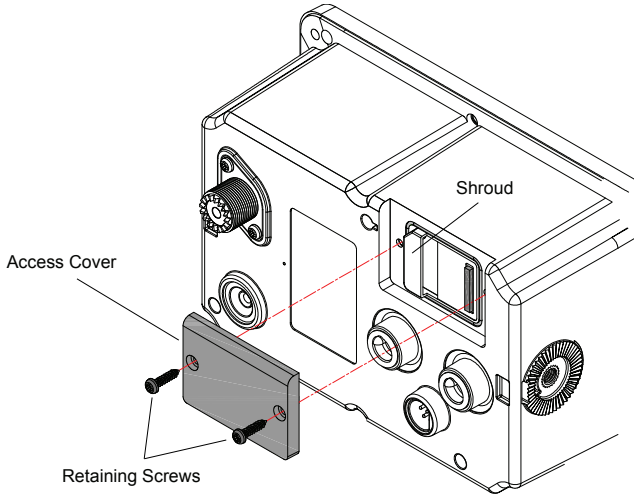

Fig. 2.5 - SD Card Access Cover

**Note** *DO NOT insert or remove the SD card while the AI50 is powered up.*

Locate and undo the two retaining screws, and carefully remove the cover to reveal the SD card slot.

With the SD card contact side down, place under the shroud and slide firmly into place, making sure the card is sitting squarely and not at an angle.

Replace the cover and screw back into place, making sure not to over tighten the screws.

**Note** *The use of high speed SD cards is not recommended. Use Class 1 SD cards only.*

## 3 KEYPAD OVERVIEW

### 3.1 Layout

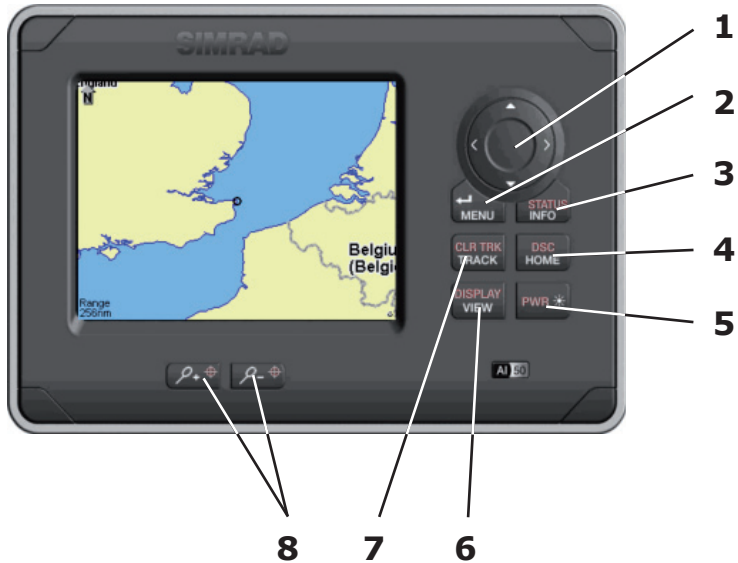

Fig. 3.1 - AI50 Automatic Identification System

### Keypad Functions

1. 8-way NavPad
2. ENTER/MENU
3. INFO/STATUS
4. HOME/DSC
5. PWR/\* (Lighting)
6. VIEW/DISPLAY
7. TRACK/CLR TRK
8. Zoom In/Out

### 3.2 PWR/Lights key (Powering on and off)

To turn the AI50 on, press the PWR/\* key.

**Note** *When turning your AI50 on for the first time, you will be directed to configure it for full use. If this is declined the AI50 will only function as a receiver until fully configured. (Refer to chapter 4).*

To turn the AI50 off, press and hold the PWR/\* key for a few seconds.

### 3.3 Navigation Keys

The circular 8-way NavPad, (Fig. 3.1 Item 1) can operate in a variety of ways depending on which mode the unit is in.

#### 3.3.1 Display Mode

The ▲▼◀▶ keys are used to position the cursor around the screen. By using a combination of keys, for example, pressing the ▲ and the ◀ together, the cursor will move diagonally up and to the left.

#### 3.3.2 Menu Mode

The ▲▼ keys are used to highlight menu items before selecting them. The ▶ key is used to select a new menu item, or go further into an item's sub menu. A single press of the ◀ key returns you to the previous menu or mode. Press and hold the ◀ key returns you to the Display Mode

#### 3.3.3 Data Entry Mode

During data entry, the ▲▼◀▶ keys are used to highlight characters and numbers before using the ↵ MENU key to select them.

### 3.4 Zoom Keys

In Display Mode the key has two functions:

A short single press, will increase or decrease the range shown in the display about your current position.

Press and holding, will increase or decrease the range shown in the display about the cursor.

### 3.5 ENTER/MENU

Pressing the ↵ MENU key in any display mode, will select "Menu Mode" and display the menu in the top left corner.

When navigating within a menu, once an item has been highlighted, pressing the ↵ MENU key will select that item or sub menu.

When in data entry mode the ↵ MENU key is used to enter that data into the systems memory.

### **3.6 INFO/STATUS**

A short press allows you to view the received information of a vessel that has been highlighted using the cursor. Press and holding the Info key will show your own vessel's information in a column on the right side of the display.

### **3.7 TRACK/CLR TRK**

The AI50 can show the track of a selected vessel. A single press toggles tracking mode on/off. Press and holding, will clear all displayed tracks.

### **3.8 HOME/DSC**

Resets the view and your own vessel's position to the centre of the display or the offset position if activated. Press and holding the HOME/DSC key initiates a DSC call, to a highlighted vessel, via an installed, compatible SimNet VHF radio.

### **3.9 VIEW/DISPLAY**

Toggle between views (HEADUP, NORTHUP, COGUP). Press and hold to access Text Mode in which the map is replaced by a list of target vessels and their details. While in Text Mode, short presses of the "VIEW/TEXT" key will cycle through the predefined order in which the vessels are sorted. Press and hold again to restore map view.

### **3.10 PWR/☼ (Backlight adjustment)**

Short presses of the PWR/Lights key will cycle through preset lighting levels.

Press and holding will power the unit down.



## 4 INITIAL CONFIGURATION

### 4.1 Window Display convention

Throughout the operation of the AI50 all displays will conform to the following convention for daylight settings:

#### Title Bar:

This is the top bar of a window, and will display the title or type of warning/alarm being displayed. In information and menu windows the Title Bars will be “Blue”. In general alert windows it will be “Yellow” and in windows displaying serious alarms, it will be “Red”.

#### Information area:

The middle portion of the window will show the information/menu or graphic relevant to the title displayed and will be grey.

#### Instruction Bar:

The lower bar in the window is known as the “Instruction Bar”. This bar will inform you of what action to perform, relevant to the information being shown, and will normally be “White”. For general alerts it will be “Yellow” and for serious alarms it will be “Red”.

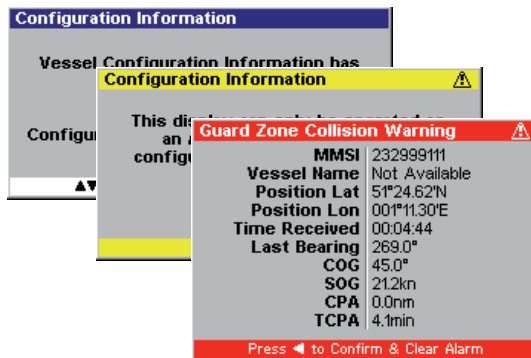

Fig. 4.1 - Window convention

### 4.2 Initial Start Up Sequence

On initial power up the display will show a warning regarding good seamanship Fig. 4.2.

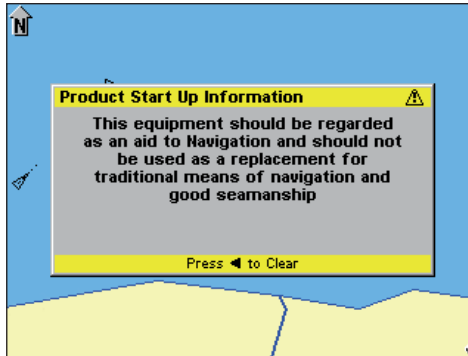

Fig. 4.2 - Start Up Screen

Press [left arrow] to clear this window and continue. If you have not previously configured the unit, a new Information window appears asking if you wish to configure the AI50 for full operation now. The default value is “Yes” as shown in Fig. 4.3.

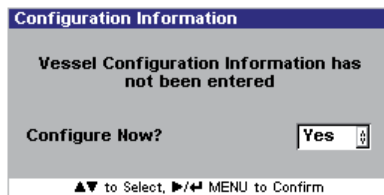

Fig. 4.3 - Configuration request

If you wish to configure your AI50 now, press [left arrow] MENU to continue go to section 4.3.1. Use the ▲ ▼ keys to change the value to “No”, then press [left arrow] MENU to confirm.

If you select “No” the following message will be displayed Fig. 4.4.

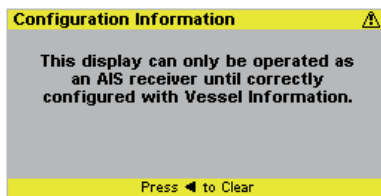

Fig. 4.4 – Configuration warning

Pressing [left arrow] will return you to the Display Mode as shown in section 6.1

If you decide not to enter your MMSI at this stage, it can be entered later from within the System setup menu, refer to section 5.6.3. However, you will not be permitted to enter any other information about your vessel until MMSI entry has been completed.

**Note** *Your AI50 will only operate as a receiver, until you have fully completed the ship configuration as described in Section 4.3.*

### 4.3 Ship Configuration Procedure

From the Display Mode, press the  $\leftarrow$  MENU key to enter Menu Mode. Scroll down the displayed menu using the  $\blacktriangledown$  key to “System Setup”, and press  $\leftarrow$  MENU or  $\blacktriangleright$ .

Scroll down the system setup menu using the  $\blacktriangledown$  key to “Ship Configuration”, press  $\leftarrow$  MENU or  $\blacktriangleright$ . A more detailed procedure is explained from section 4.3.1 onwards.

All values selected during this procedure will be automatically stored in the AI50 memory once completed.

#### **WARNING**

***All data entered during this procedure can be edited at any time, except the MMSI. Once this has been entered and confirmed it will become locked and shown as greyed out. Indicating that it can be viewed, but not edited.***

Should it become necessary to change your MMSI, for example, if you wish to re-install your AI50 into a new vessel; you will need to contact your local Simrad dealer about reprogramming a new number.

#### 4.3.1 MMSI Entry

If you have selected "YES" when asked to “Configure Now”, a warning window will appear Fig. 4.5.

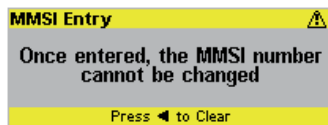

*Fig. 4.5 – MMSI Entry warning*

Press the  $\blacktriangleleft$  key to clear the message and continue. The warning disappears from the screen and you are now ready to enter your MMSI number Fig. 4.6.



Fig. 4.6 – MMSI Entry display

Using the ▲▼◀▶ keys highlight the first number of your MMSI and press the ↵ MENU key to select it. The first number appears in the display and the cursor moves on to the second. Repeat this procedure until every number has been entered.

If you enter an incorrect number in error, use the ▲▼◀▶ keys to highlight the "◀" or "▶" and press ↵ MENU to move the cursor onto the position of the error. When the cursor is in the correct position, use the ▲▼◀▶ keys to highlight the correct number and press the ↵ MENU to select it. Continue to enter the rest of your number until complete.

Once you are sure that your MMSI number is correct, highlight "OK" and press the ↵ MENU key.

**Note** "OK" will only function if all digits have been entered.

Once your MMSI number has been entered the entry screen will change, this time the title bar will read "Confirm MMSI Entry". You must now repeat the above entry procedure to confirm your MMSI entry.

Once you are sure that your confirmation is correct, highlight "OK" and press the ↵ MENU key.

If both entries are identical the following message will be displayed confirming a successful entry. Fig. 4.7.



Fig. 4.7 - MMSI Confirmation

Press the ◀ key, the display will change to the “Vessel Configuration Information” window (Section 4.3.2), to enter the remaining ships configuration information.

If the two entered MMSI numbers do not match, a message indicating this will be shown Fig 4.8.

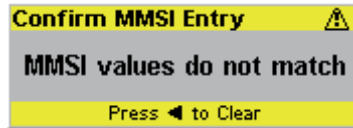

Fig. 4.8 - MMSI mismatch warning

Press the ◀ key, the display will revert back to the Configuration Request window Fig. 4.3.

If you need to cancel the input mode, highlight the CANCEL button and press ↵ MENU. A warning will be shown in the display Fig. 4.9.



Fig. 4.9 - MMSI cancelled warning

Press the ◀ key, and the display will revert back to the Configuration Request window Fig. 4.3.

Once the MMSI number has been entered and confirmed, the next stage of the configuration is highlighted. The MMSI number is now shown as greyed-out and locked into the system memory; no further changes can be made to it except by an authorised agent. Fig. 4.10.

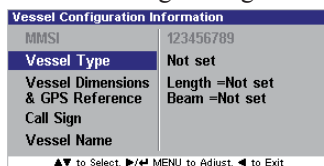

Fig. 4.10 – Vessel configuration list

### 4.3.2 Vessel Type Entry

Press ↵ MENU or ▶ to select “Vessel type”, “Not Set” will be highlighted. Fig. 4.11.

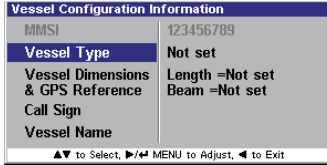

Fig. 4.11 – Vessel Type Entry Screen

The ▲ ▼ keys allow you to cycle through the available choices, they are:

- Not Set (default)
- Pleasure Craft
- Sailing Vessel
- Military
- Diving Ops
- Dredging
- Tow Large Load
- Towing
- Fishing

When you have made your choice, press ◀ MENU to select it and enter it into the systems memory.

### 4.3.3 Vessel Dimensions & GPS Reference

Using the ▲ ▼ ◀ ▶ keys highlight “Vessel Dimensions & GPS Reference” and press ◀ MENU or ▶ to select it. A window opens as shown in Fig. 4.12.

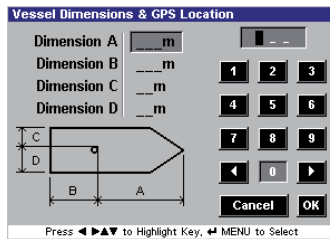

Fig. 4.12 – Vessel Dimensions & GPS Reference Entry Screen

All numeric entries must include preceding zero's. For example if “DimA” is 20 metres, it should be entered as “020” and not “20” before the “OK” is selected, if not the following message will appear. Fig. 4.13.

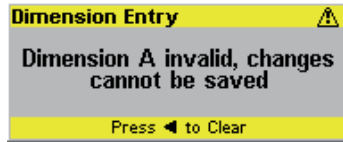

Fig. 4.13 - Dimension entry error

Enter the required dimensions of your vessel (in metres), with reference to the GPS antenna, using the same method of entry as described during MMSI entry. As you enter each dimension the cursor will advance to the next one until all have been entered. Select "OK" and press  $\leftarrow$  MENU to accept your entry. The display returns to the vessel configuration Information window.

If you have entered an incorrect number in error, highlight either the " $\leftarrow$ " or " $\rightarrow$ " and pressing the  $\leftarrow$  MENU key until the cursor is on the error position.

Now using the  $\blacktriangle$   $\blacktriangledown$   $\blacktriangleleft$   $\blacktriangleright$  keys, highlight the correct number and press the  $\leftarrow$  MENU to select it. Once you entry is complete highlight "OK" and press  $\leftarrow$  MENU to accept.

#### 4.3.4 Call Sign Entry

Using the  $\blacktriangle$   $\blacktriangledown$  keys highlight "Call Sign", and press  $\leftarrow$  MENU or  $\blacktriangleright$  to select it. A window opens as shown in Fig. 4.14.

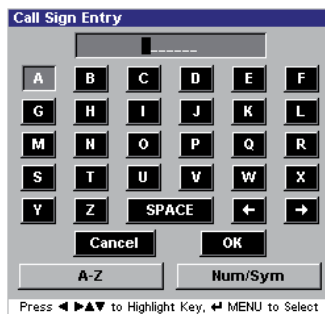

Fig. 4.14 – Call Sign Entry Screen

Enter the Call Sign of your vessel using the same method of entry as described during MMSI entry. When complete highlight the OK button and press  $\leftarrow$  MENU to store it in the system memory.

If you have made an error in your entry, see section 4.3.3 for a description

of how to correct it.

### 4.3.5 Vessel Name Entry

Using the ▲▼ keys highlight “Vessel Name”, and press ← MENU or ► to select it. A window opens identical to the call sign entry window in Fig. 4.13 but with “Vessel Name Entry” in the title bar.

Enter your vessel’s name using the same method of entry as described during MMSI entry. When complete highlight the OK button and press ← MENU to store it in the system memory.

Once the Vessel Name has been entered, the display returns to the Vessel Configuration Information menu, Fig. 4.15.



Fig. 4.15 – Completed vessel configuration

Configuration is now complete and stored in the system’s memory ready for use.

To exit the configuration menu, press the ◀.

## 5 MENU MODE

### 5.1 General

The AI50 has many advanced features that are user configurable. These options can be accessed by pressing  $\leftarrow$  MENU during any display mode. A window opens in the top left corner displaying the Main menu options as shown in Fig. 5.1.



Fig. 5.1 – Menu Mode Display

### 5.2 Display Mode settings

This section will change the way the display looks when in operation.

From the Main menu select “Display Mode”, and press  $\leftarrow$  MENU or  $\blacktriangleright$ . A sub menu opens displaying the various options and their current status, as shown in Fig. 5.2.

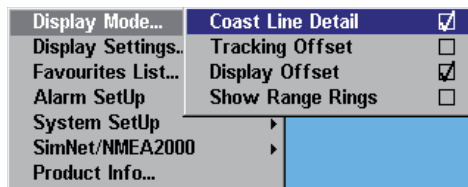

Fig. 5.2 – Display Mode Options

#### 5.2.1 Coastline Detail

This option allows you to toggle the coastline detail on/off. The default value is “on” and a tick is shown in the box. To toggle this option on/off, highlight it and press  $\leftarrow$  MENU or  $\blacktriangleright$ .

#### **WARNING**

***The coastline map is a visual aid to assist with orientation and range. It is not a marine chart and must not be used as a substitute for accurate charting***

### 5.2.2 Tracking Offset

This option allows you to track the progress of your own vessel in relation to all other AIS equipped vessels within your VHF range.

Your vessel is shown as a boat shaped icon and will start to track away from the centre of the screen in the direction of your heading.

As your vessel icon approaches the edge of the screen, the display will refresh and scroll forward putting your vessel back to the centre again.

The default value for this option is “off”, the box will not be ticked. To toggle this option on/off, highlight it and press **↵** MENU or **▶**, and a tick will appear in the box.

When set to “on” your vessel is no longer maintained at the centre of the display, and will be allowed to track away.

### 5.2.3 Display Offset

This option allows you to toggle the display offset on/off. The default value for this option is “off”, and the box will not be ticked.

To toggle this option, highlight it and press the **↵** MENU or **▶**. Your vessel is now offset to the lower half of the screen, allowing a greater range to be displayed in front of you, Fig. 5.3.

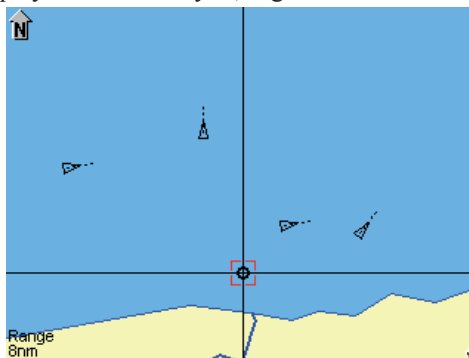

Fig. 5.3 – Display Offset on

**Note** This mode is limited to “COG-UP” or “HDG-UP” view points.

The display only has one position, and is generally only available as

Head-Up mode. Your vessel will be shown in the lower half of the screen and pointing towards the top. It will remain like this for the duration of this mode, and when your vessel turns, the map will rotate about it.

**Note** *If in this mode you start tracking your own vessel, if “Show Range Rings” is activated, the range rings will disappear and the boat will move up the display under its own heading.*

**Note** *The display could also work for a COG-Up, but the relationship between the vessel and the map might not be representative of actual events taking place, due to the influences of the wind and tide. Therefore, if no compass is connected to the system, this mode will automatically appear as COG-Up.*

### 5.2.4 Show Range Rings

This option allows you to toggle the range rings on and off. The default value is “off” and no tick is shown in the box. To toggle this option on/off, highlight it and press the ← MENU or ►.

When set to “off” the range rings disappear from the display, however, the overall range is still displayed in the lower left corner of the screen.

## 5.3 Display Settings

This section will configure the way the display and keyboard will look.

From the main menu highlight “Display Settings” and press ← MENU or ►. A sub menu opens displaying the various settings and their current values as shown in Fig. 5.4.

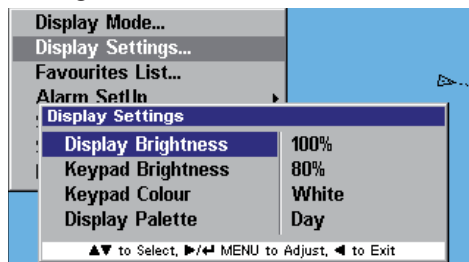
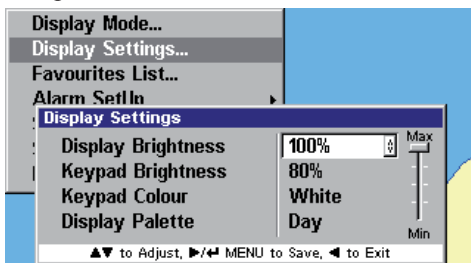

Fig. 5.4 – Display settings menu

### 5.3.1 Display Brightness

This option allows you to change the brightness of the display in steps of 10%.

Using the ▲▼ keys highlight “Display Brightness” and press ↵ MENU or ► to select it. This opens a box with the current value in as shown in Fig. 5.5.



*Fig. 5.5 – Changing display settings*

Use the ▲▼ keys to adjust the Display Brightness to a suitable level, between 0 – 100%, then press ↵ MENU or ► to store it.

Press ◀ to exit and return to the previous menu.

### 5.3.2 Keypad Brightness

This option allows you to change the brightness of the keypad in 10% steps.

Using the ▲▼ keys highlight “Keypad Brightness” and press ↵ MENU or ► key to select it. This opens a box with the current value in. Use the ▲▼ keys to adjust the Keypad Brightness to a suitable level, between 0 – 100%, then press ↵ MENU or ► to store it.

Press ◀ to exit and return to the previous menu.

### 5.3.3 Keypad Colour

This option allows you to change the colour of the keypad backlighting .

Using the ▲▼ keys highlight “Keypad Colour” and press ↵ MENU or ► to select it. This opens a box with the current value in. Use the ▲▼ to change the colour, between White and Red, then press ↵ MENU or ► to store it.

Press ◀ to exit and return to the previous menu.

### 5.3.4 Display Palette

This option allows you to change the display colour palette from a bright high visibility one ideal for daytime operation, to a low intensity one ideal for night time operation.

Using the ▲▼ highlight “Keypad Palette” and press ←MENU or ► to select it. This opens a box with the current value in. Use the ▲▼ keys to change the colour between Day and Night, then press ←MENU or ► to store it.

Press ◀ to exit and return to the previous menu.

## 5.4 Favourites List

Vessels can be added to a “Favourites List” and an alarm set, so that you receive an alert when a vessel on your list comes within VHF range. (To set the alarm, refer to section 5.5.3). There are two methods for adding vessels to your list.

### 5.4.1 Add an Entry

**Method one** - From the main menu and select “Favourites List” then press ←MENU or ►. A window will open showing the current list of favourites, Fig. 5.6.

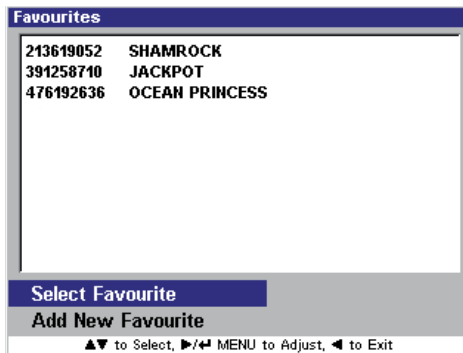

Fig. 5.6 - Favourites list (non selectable)

Using the ▲▼ keys highlight “Add New Favourite”, and press ←MENU or ►. The display changes showing the two available data entry fields, Fig. 5.7.



Fig. 5.7 – Adding a Favourite

To enter the vessel's MMSI highlight it and press  $\leftarrow$  MENU or  $\blacktriangleright$ . The "Favourite MMSI Entry" window opens, this entry procedure is identical to entering your own MMSI number, (see section 4.3.1). Once completed select "OK" and press  $\leftarrow$  MENU. The display will return to the previous window, Fig 5.8.



Fig. 5.8 – New Favourite added

Next, highlight "Vessel Name" and press  $\leftarrow$  MENU or  $\blacktriangleright$ . The "Vessel Name Entry" window opens, this entry procedure is identical to entering your own Vessels Name, (see section 4.3.5). Once completed select "OK" and press  $\leftarrow$  MENU. The display returns to the previous window, Fig 5.8.

**Note** *A favourite can be added to the list with just an MMSI number, but cannot be added with just the vessel name. Unlike your own vessels MMSI number, this MMSI can be changed, edited or deleted once entered.*

*If an entry is inserted without the name, the next time that vessel is in range the name will be inserted automatically. If a name already exists in that field then it will not be overwritten.*

Press  $\blacktriangleleft$  to exit and return to the previous menu.

**Method Two** - In Map Mode, Using the  $\blacktriangle\blacktriangledown\blacktriangleleft\blacktriangleright$  keys, place the cursor over the selected vessel, and a highlighted box will appear. Press the INFO key once, and the display changes to show a summary of that vessel's information. Press the INFO key a second time and a full listing of the information appears. Now Press  $\leftarrow$  MENU to add this vessel to your list.

### 5.4.2 Edit an Entry

From the Favourites List highlight "Select Favourite" and press the  $\leftarrow$  MENU or  $\blacktriangleright$ . The top vessel is now highlighted. Using the  $\blacktriangle\blacktriangledown$  keys highlight the vessel you wish to edit and press  $\leftarrow$  MENU or  $\blacktriangleright$ . A menu window opens with the available options as shown in Fig. 5.9.

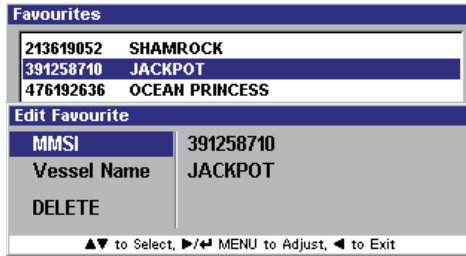

Fig. 5.9 - Editing a Favourite

Highlight the field you wish to edit and press ◀ MENU or ►. Editing the MMSI number is described in section 4.3.1 and editing the Vessel Name is described in section 4.3.5

Press ◀ to exit and return to the previous menu.

### 5.4.3 Delete an Entry

From the Favourites List highlight “Select Favourite” and press ◀ MENU or ►. The highlighter bar is now on the top favourite in the list. Using the ▲ ▼ keys highlight the item you wish to delete and press ◀ MENU or ►.

The window shows three choices “MMSI”, “Vessel Name” and “DELETE”. Highlight “DELETE” and press ◀ MENU or ►.

## 5.5 Alarm Setup

This section allows you to activate/deactivate and setup parameters of the various safety alarms on your AI50.

For detailed information about alarm messages, please refer to section 7.2.

From the main menu select “Alarm Setup” and press ◀ MENU or ►. A sub menu opens displaying the various types of alarms as shown in Fig. 5.10

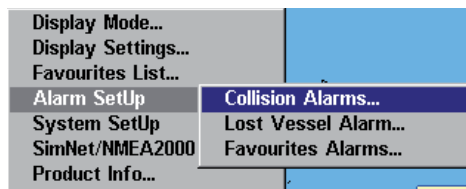

Fig. 5.10 – Alarm list

Using the ▲▼ keys highlight the Alarm type you wish to activate or change and press ↵ MENU or ►.

### 5.5.1 Collision Alarm

This alarm aids in the prevention of a collision at sea by calculating the Closest Point of Approach, (CPA), and the Time to Closest Point of Approach, (TCPA), from the received position, COG and SOG of the AIS transmissions, from all AIS equipped vessels in your VHF range.

From the “Alarm Setup” menu select “Collision Alarm”, the display will change to show the activation status and values. The default is “Not Active”. Fig. 5.11.

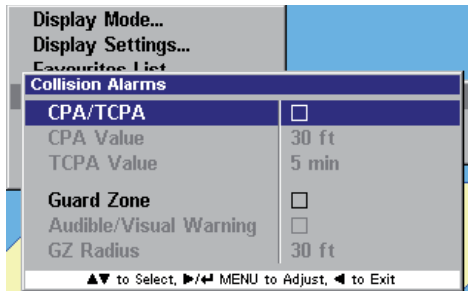

Fig. 5.11 – Collision Alarms

#### 5.5.1.1 CPA/TCPA

When you activate the CPA/TCPA Alarm from within the Alarm Setup Menu, the CPA/TCPA will be calculated for all AIS equipped vessels in your VHF range.

**Note** *CPA – Closest Point of Approach is the calculated distance of how close a vessel will pass.*

*TCPA – Time to Closest Point of Approach is the calculated time to reach the CPA*

When both the CPA and TCPA values calculated by the AI50 are less than, or equal to the values set by the user, then an alarm will sound, and a warning will be displayed.

### WARNING

***The CPA/TCPA values are set by the user, as described***

**above. It is the responsibility of the user to determine how close another vessel may pass without being dangerous, and how quickly the user can react to manoeuvre their own vessel to avoid a collision.**

To activate the “CPA/TCPA” alarm, highlight it and press the ← MENU or ► key. A tick will appear in the box, to indicate the alarm is now active and using the values shown.

To change “CPA Value” use ▲ ▼ keys to highlight it then press the ← MENU or ► key to select it. The value field is now highlighted. Fig. 5.12.

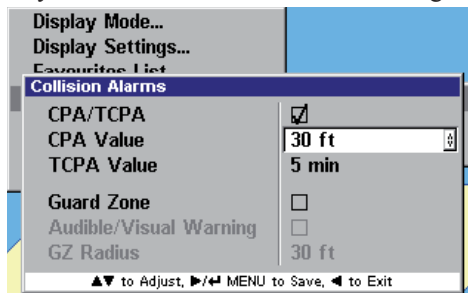

*Fig. 5.12 - CPA/TCPA values*

Use ▲ ▼ to cycle through the predefined values and select an appropriate one, (30ft – 8.1nm or equivalent in selected units), then press ← MENU or ◀ to accept it. The cursor returns to highlight “CPA Value”.

Press ◀ to exit and return to the previous menu.

To change “TCPA Value” use ▲ ▼ keys to highlight it and press the ← MENU or ► key to select it. The value field is now highlighted.

Use ▲ ▼ to cycle through the predefined values and select an appropriate one, (5 min – 95min), then press ← MENU or ◀ to accept it. The cursor returns to highlight “TCPA Value”.

If the calculated values are less than or equal to the values set by the user, an alarm condition will exist.

### **5.5.1.2 Guard Zone**

This option allows you to set a perimeter around your vessel. When activated a red ring will appear around your vessel in the display, labelled

“GZ”. Any AIS equipped vessel at a distance less than, or equal to the value set by the user, will trigger an alarm and its icon will turn red. An optional audible/visual warning can also be triggered if activated during setup.

To activate the “Guard Zone” alarm, highlight it and press the **↵** MENU or **▶** key. A tick will appear in the box, to indicate the alarm is now active and using the values shown.

**Audible/Visual Warning**

To activate the “Audible/Visual Warning”, highlight it and press the **↵** MENU or **▶** key. A tick will appear in the box, to indicate the alarm is now active.

**GZ Radius**

To change “GZ Radius” use **▲▼** keys to highlight it then press **↵** MENU or **▶** to select it. The value field is now highlighted.

Use **▲▼** to cycle through the predefined values and select an appropriate one, (35ft – 27nm or equivalent in selected units), then press **↵** MENU or **◀** to accept it. The cursor returns to “Collision Alarms” menu and the display changes as shown in Fig. 5.13.

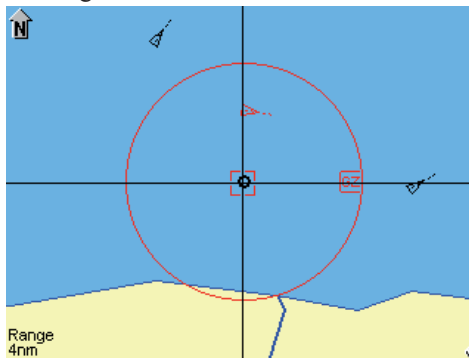

*Fig. 5.13 – Guard Zone active*

Press **◀** to exit and return to the previous menu.

**5.5.2 Lost Vessel Alarm**

A Lost Vessel Alarm occurs when the reception from a vessel has been lost for a period of time, which has been determined by its missed transmission periods and last known speed.

This function allows the user to activate a warning message each time a vessel is lost from within the current display range.

From the “Alarm Setup” menu select “Lost Vessel Alarm”, the display changes to show the activation status and current setting, Fig. 5.14.

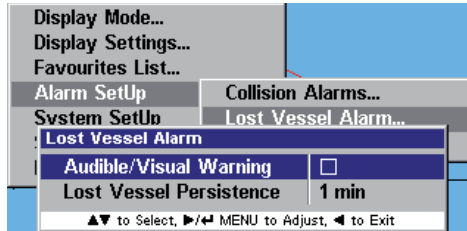

Fig. 5.14 – Lost Vessel Alarm

### Audible/Visual Warning

This section will activate an audible and visual alarm each time a vessel is lost from AI50 reception.

To activate the “Audible/Visual Warning”, highlight it and press ◀ MENU or ►. A tick will appear in the box, to indicate the alarm is now active and using the value shown.

### Lost Vessel Persistence

When a vessel has been lost from AI50 reception, its icon will change to a vessel icon with a strike through it. (Refer to section 6.2). Lost vessel persistence is the user assignable time period for which this lost vessel icon will remain on the screen.

To change “Lost Vessel Persistence” use ▲ ▼ keys to highlight it and press ◀ MENU or ► to select it. The value field is now highlighted.

Use ▲ ▼ to cycle through the predefined values and select an appropriate one, (1 min – 30 min), then press ◀ MENU or ◀ to accept it. The cursor returns to highlight “Lost Vessel Persistence”.

Press ◀ to exit and return to the previous menu.

## 5.5.3 Favourites Alarm

This option allows you to be notified if a vessel in your “Favourites List” comes within VHF range.

To activate the “Favourites Alarm”, highlight it and press **←** MENU or **▶**. A tick will appear in the box, to indicate the alarm is now active.

Press **◀** to exit and return to the previous menu.

## 5.6 System Setup

This section is where you customise the AI50 to function how you want.

From the Main menu select “System Setup”, and press **←** MENU or **▶**. A menu window showing the following range of options:

- Units of Measure
- Set Local Time
- Ship Configuration
- Key Beeps
- Set Language
- Data Logging
- Transmit Enable
- Reset Options

### 5.6.1 Units of Measure

This section allows you to change the units of distance and speed. The options are as follows:

- Distance in:   Nautical Miles (default)  
                  Miles  
                  Kilometres
  
- Speed in:       Knots (default)  
                  MPH  
                  KPH

From the System Setup menu select “Units of Measure” and press **←** MENU or **▶**. A window opens showing a choice of “Distance” or ”Speed units”, Fig. 5.15

Highlight the one you wish to change then press **←** MENU or **▶**. Using **▲** **▼** to cycle through the options then press **←** MENU or **▶** to select it.

Press **◀** to exit and return to the previous menu.

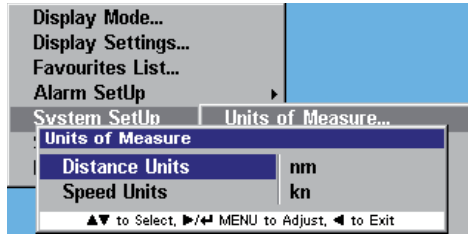

Fig. 5.15 - Units of Measure

### 5.6.2 Set Local Time

This section allows you to apply an offset to the GPS's UTC as displayed in "Own Vessel Information".

From the System Setup menu select "Set Local Time", and press ◀ MENU or ►. A window will open displaying "Set Local Time", Fig. 5.16.

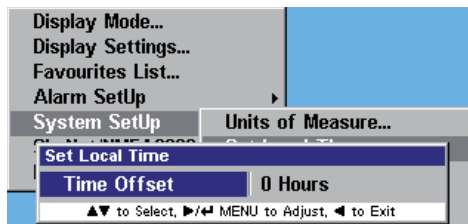

Fig. 5.16 – Set Local Time

Press ◀ MENU or ► to enter an offset. Using ▲▼ cycle through the range (-13 to +13 hours), to the appropriate offset and press ◀ MENU or ► to select it.

Press ◀ to exit and return to the previous menu.

**Note** *This will only affect the time being displayed in the own vessel information bar. All received vessel information will be displayed as UTC.*

### 5.6.3 Ship Configuration

This section allows you to enter and edit information about your vessel such as:

- MMSI Number (If not initially entered and confirmed)
- Vessel Type
- Vessel Dimensions and GPS Reference

- Call Sign
- Vessel Name

For a detailed explanation of how to configure your vessel, refer to section 4.3.

### 5.6.4 Key Beeps

This function toggles the sound the AI50 makes when a key is pressed.

From the System Setup menu select “Key Beeps”, press  $\leftarrow$  MENU or  $\rightarrow$ , the display changes to show a box with a tick in, this is the default setting. Pressing  $\leftarrow$  MENU or  $\rightarrow$  will toggle this option on/off.

Press  $\leftarrow$  to exit and return to the previous menu.

### 5.6.5 Set Language

This section allows you to change the operating language of your AI50.

From the System Setup menu select “Set Language”, and press  $\leftarrow$  MENU or  $\rightarrow$ , the display changes to show a list of available languages, as show in Fig. 5.17, English being the default choice.

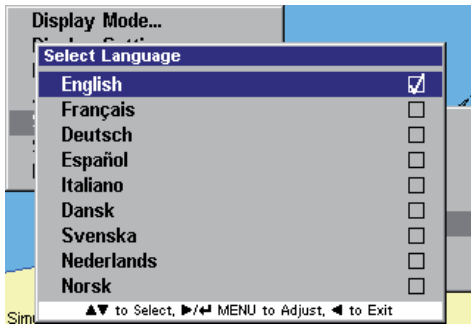

Fig. 5.17 – Language list

Using the  $\blacktriangle$   $\blacktriangledown$  keys highlight the language you wish the AI50 to operate in and press  $\leftarrow$  MENU or  $\rightarrow$ . A tick will appear in the box of your chosen language.

Pressing the  $\leftarrow$  key will return you directly to the Map Mode.

### 5.6.6 Data Logging

This function enables you to store an electronic record, of the dynamic

and static data received from all vessels within VHF range, during a voyage, including your own vessel's data.

**Note** *In order to use the Data Logging function, you will require an SD card.*

The installation procedure of the SD card, can be found in section 2.8.

### 5.6.6.1 Enabling

To enable data logging on your AI50, first you have to select a data file name, that the information will be stored under.

From the System Setup menu select "Data Logging", and press  $\leftarrow$  MENU or  $\blacktriangleright$ . A window opens displaying the options as shown in Fig. 5.18.

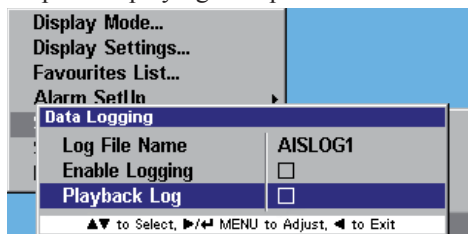

Fig 5.18 – Logging menu

Select "Log File Name" and press  $\leftarrow$  MENU or  $\blacktriangleright$ . The "File Name" is highlighted. Using the  $\blacktriangle$   $\blacktriangledown$  keys cycle through the predefined names (AISLOG1 to AISLOG10), then press  $\leftarrow$  MENU or  $\blacktriangleright$  to select one.

Highlight "Enable Logging" and press  $\leftarrow$  MENU or  $\blacktriangleright$ . A tick will appear in the box and the file name will be greyed out. All data for your voyage will now be stored under this file name.

**Note** *If you enter this menu with a log file open, you will only be able to end logging.*

Pressing the  $\blacktriangleleft$  key returns you to the previous menu and a pop-up window informs you that the file has been created.

Logging is now enabled, all information being received will now be recorded onto the installed SD card, under the selected file name.

If you have omitted to fit an SD card into your AI50 or you have a non compatible SD card, when you try to enable logging the following

message will be shown in the display, Fig. 5.19.



Fig 5.19 – Logging failure

### 5.6.6.2 Disabling

From the System Setup menu select “Data Logging”, press ◀ MENU or ▶. A window opens displaying the options as shown in Fig. 5.18.

Highlight “Enable Logging” then press ◀ MENU or ▶. The tick disappears and the file name above is no longer greyed out.

Pressing the ◀ key returns you to the previous menu and a pop-up window informs you that the file is OK.

**Note** *If the data logging is not disabled correctly before powering down, all data could be lost.*

*Disabling a log file will not delete any of the data stored on it.*

### 5.6.6.3 Playback Log

To playback a data log on your AI50, first you have to select the correct data file name for the voyage you wish to replay.

From the System Setup menu select “Data Logging”, and press ◀ MENU or ▶. A window opens displaying the options as shown in Fig. 5.18.

Select “Log File Name” and press ◀ MENU or ▶ key. The “File Name” is now highlighted.

Using the ▲ ▼ keys cycle through the predefined file names until you find the one you wish to replay, then press ◀ MENU or ▶ to select it.

Highlight “Playback Log” and press ◀ MENU or ▶ to enable it. A tick will appear in the box and the file name will be greyed out.

**Note** *If you enter this menu with a log file open, you will only be able to end playback.*

Press ◀ to exit and return to the previous menu.

### 5.6.7 Transmit Enable

This option allows you to Enable/Disable the AI50's VHF transmitter, rendering you either visible/invisible to other AIS equipped vessels in your VHF range.

From the "System Setup" menu highlight "Transmit Enable" and press ↵ MENU or ▶ to select it. Press ↵ MENU or ▶ to toggle the option On/Off.

Press ◀ to exit and return to the previous menu.

### 5.6.8 Reset Options

Selecting this option will reset all system variables back to their factory default settings, except for the ship's configuration.

From the System Setup menu select "Reset Options", and press ↵ MENU or ▶. The Reset Options window will open as shown in Fig. 5.20.

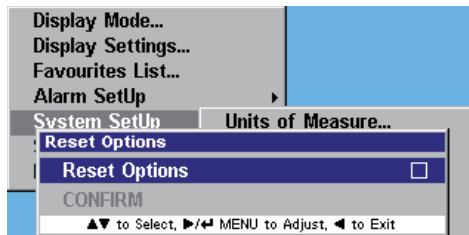

Fig. 5.20 – Reset Option

To perform a system reset press ↵ MENU or ▶, a tick appears in the box. Highlight "CONFIRM" and press ↵ MENU or ▶ again. A window will open confirming that the system has been reset. Fig. 5.21.

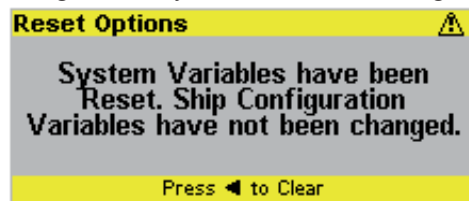

Fig. 5.21 – Reset Confirmed

Press ◀ to clear the message and return to the display mode.

## 5.7 SimNet/NMEA2000

From the Main menu select “SimNet/NMEA2000”, and press  $\leftarrow$  MENU or  $\blacktriangleright$ . A window opens showing the following choices:

- Data Sources
- Network Management
- Network List
- Remote Enable
- DSC Radio Select

### 5.7.1 Data Sources

This section allows you to select a SimNet/NMEA2000 data source, to provide compass heading information.

**Note** *This data source must be able to supply magnetic compass heading.*

From the System Setup menu select “SimNet/NMEA2000”, highlight “Data Source” and press  $\leftarrow$  MENU or  $\blacktriangleright$ . The “Data Source” window will open with the “Heading” Highlighted. Press  $\leftarrow$  MENU or  $\blacktriangleright$  to highlight source list. Fig. 5.22.



Fig. 5.22 – Data Source menu

Using the  $\blacktriangle$   $\blacktriangledown$  keys cycle through the options, then press  $\leftarrow$  MENU or  $\blacktriangleright$  to select your choice.

Press  $\blacktriangleleft$  to exit and return to the previous menu.

### 5.7.2 Network Management

From the SimNet/NMEA2000 menu select “Network Management”, and press  $\leftarrow$  MENU or  $\blacktriangleright$ . The Network Management window opens showing “Device Instance” and “System Instance”

### 5.7.2.1 Device Instance

This option will normally be used on large complicated systems, where there maybe more than one radio system or AIS on the same SimNet bus. For example, the system may contain more than one AI50.

To prevent conflict across the network, these can each be assigned a unique device number between 0 and 255 in steps of 1. Fig. 5.23.

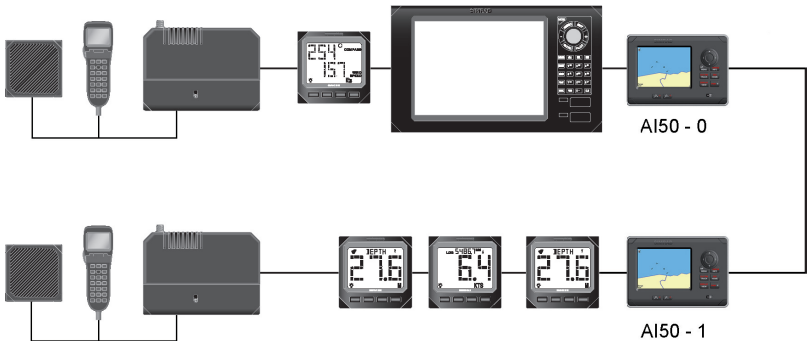

Fig. 5.23 – Device Instance

From the Network Management highlight “Device Instance” and press the **←** MENU or **▶** key. Using the **▲** **▼** keys select a Device Instance number and press **←** MENU or **▶** to enter it into memory.

Press **◀** to exit and return to the previous menu.

### 5.7.2.2 System Instance

A SimNet system can have a maximum of 50 devices or “Nodes” attached to it. If a large vessel has a requirement for more than 50 nodes, then a multiple network system is required. The system Instance allows the user to allocate a unique number between 0 and 15 to each network, which allows the multiple networks to intercommunicate.

If your vessel is large enough that it is likely to require setting up multiple networks, it is strongly advised that you contact Simrad Technical Support to discuss your particular system requirements before proceeding further.

From the Network Management highlight “System Instance” and press the **←** MENU or **▶** key. Using the **▲** **▼** keys select a System Instance number and press **←** MENU or **▶** to enter it into memory.

Press ◀ to exit and return to the previous menu.

### 5.7.3 Network List

This function displays all products connected to the SimNet/NMEA2000 network. From the SimNet/NMEA2000 menu select “Network List”, and press the ◀ MENU or ▶ key. The Network List window opens, showing a list of all the products connected to the SimNet Network.

Press ◀ to exit and return to the previous menu.

### 5.7.4 Remote Enable

This option allows you to Enable/Disable the Simrad WR20 Remote Commander handset from controlling the AI50.

From the “SimNet/NMEA2000” menu select “Remote Enable” and press ◀ MENU or ▶ to select it.

Press the ◀ MENU or ▶ key again to toggle the option On/Off.

Press ◀ to exit and return to the previous menu.

### 5.7.4 DSC Radio Select

If a compatible DCS radio is installed on the SimNet network, the AI50 will enable the user to initiate a DSC call.

**Note** *DSC functions will only be available, if the MMSI number has been entered into the radio.*

From the SimNet/NMEA2000 menu highlight “DSC Radio Select”, and press ◀ MENU or ▶ to select it. A window opens showing the DSC Radio Select menu. Press ◀ MENU or ▶ to highlight list of radios.

Using the ▲ ▼ keys scroll through the list and press ◀ MENU or ▶ to make your selection.

If no radio is present on the SimNet network then “N/A” will be shown in the radio list.

Press ◀ to exit and return to the previous menu.

## 5.8 Product Info

This section will display information about your AI50's Unique Identifier, Software version and Ship Configuration information.

From the Main menu select "Product Info", and press  $\leftarrow$  MENU or  $\rightarrow$ . A window opens showing the first screen of information; press the  $\leftarrow$  key to display the second set of information, Fig. 5.24 and Fig. 5.25.

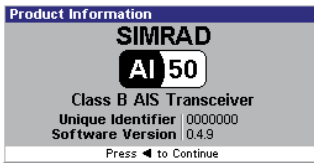

Fig. 5.24 – Product Info 1

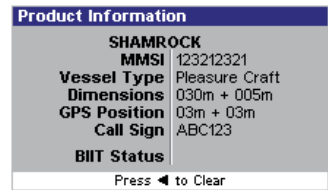

Fig. 5.25 – Product Info 2



## 6 AIS MAP MODE

### 6.1 General

This section will describe the features of the AI50 Map Mode as shown in Figure 6.1.

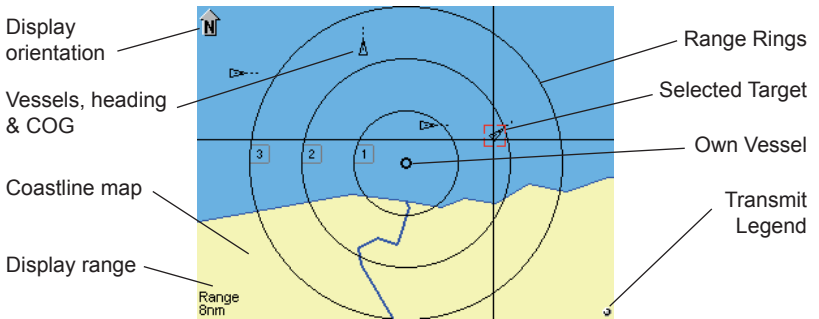
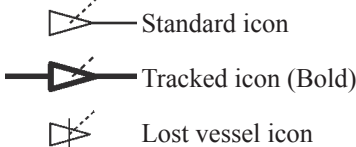

Fig. 6.1 – AI50 Display

If the unit is returning or entering the Map mode from any other display mode, the last settings remain valid.

### 6.2 Vessel Icon Detail

The AI50 displays different icons for each vessel state, they are as follows:







If a vessel displaying one of these icons goes into an alarm state, then the icon will turn red.







### 6.3 Range Rings/ Range Info

The Range rings consist of three concentric circles situated around the centre point of the display.

The screen range information is shown in the bottom left hand corner of the display, as shown in Figure 6.1; this indicates the range across the whole display.

Each circle displays range information on the left radial intersect point.

The range on your AI50 can be adjusted by using the   keys. Pressing the  increases the range across the display (zoom out) and  decreases the range across the display (zoom in).

If you wish to zoom in/out on vessels in a particular area, using the     keys, place the cursor on the selected area, press and hold either the  or  key, the display will zoom in/out at that point.

If your own vessel is still in view it will be shown as a small circle.

You can set your screen to display any of the 12 ranges, they are:

No.	Range (between rings)	Total Range (Across display)	
		Full display	(Showing own vessel info bar)
1	0.01nm	0.08nm	0.06nm
2	0.02nm	0.16nm	0.12nm
3	0.05nm	0.4nm	0.3nm
4	0.1nm	0.8nm	0.6nm
5	0.2nm	1.6nm	1.2nm
6	0.5nm	4.0nm	3.0nm
7	1.0nm	8.0nm	6.0nm
8	2.0nm	16.0nm	12.0nm
9	4.0nm	32.0nm	24.0nm
10	8.0nm	64.0nm	48.0nm
11	16.0nm	128.0nm	96.0nm
12	32.0nm	256.0nm	192.0nm

### 6.4 Point Of View

The AI50 can display information in one of three ways; “NORTH UP”, “HEAD UP” and “COG UP”. The symbol in the top left corner of the display informs you of your current view.

**Note** *HDG UP will only be available if a compass source is present.*

Pressing the DISPLAY/VIEW key, will cycle through the available options; “NORTH UP”, “HEAD UP” and “COG UP”.

As you cycle through the options, the full name will be displayed in the top left corner for 2 seconds before changing to an arrow with a relevant letter in, denoting your selected view, “N”, “H”, and “C” Fig. 6.2.

Your COG will be shown as a dashed line emanating from the centre of your vessel’s icon.

North Up – The top of the display lines up with True North.

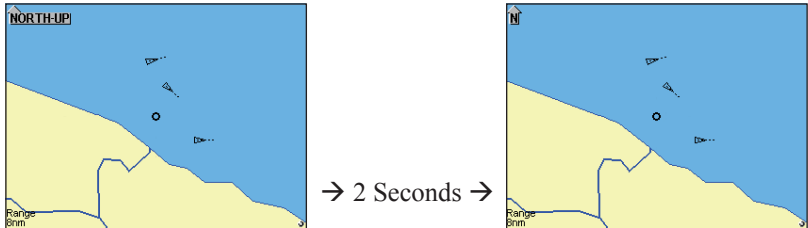

HDG Up – The top of the display lines up with the vessels True Heading.

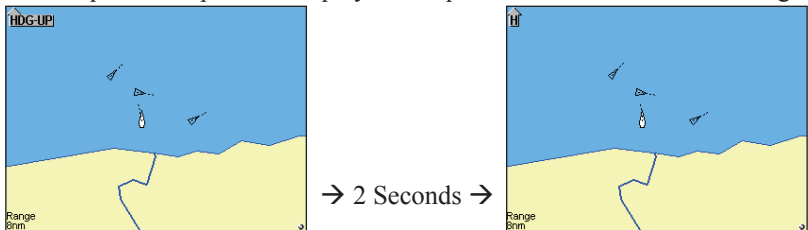

COG Up – The top of the display lines up with the vessels COG True.

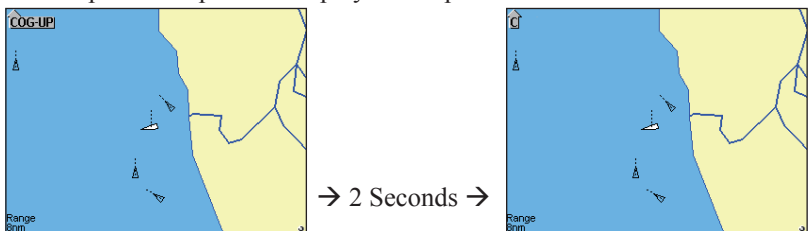

Fig.6.2 – View Modes

**Note** *The “HDG Up” option will only be available when the unit is interfaced to a suitable source of Compass Heading information through the SimNet port.*

## 6.5 Coast Line Detail

The coast line detail is drawn from internally stored worldwide maps. It

can be toggled on/off from within “Display Mode” options in the Main Menu, see section 5.2.

## WARNING

***The coastline map is a visual aid to assist with orientation and range. It is not a marine chart and must not be used as a substitute for accurate charting.***

When the coastline detail is turned off the display will turn a light shade of green which should not be confused with land mass, Fig. 6.3a and Fig. 6.3b.

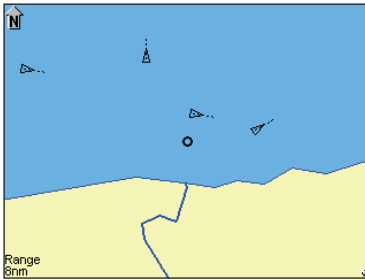

Fig. 6.3a - Coastline detail on

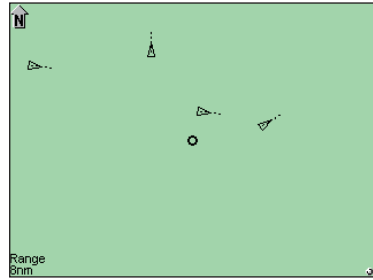

Fig. 6.3b - Coastline detail off

## 6.6 Cursor

The cursor is the intersecting horizontal and vertical lines on the display, which appear whenever the 8-way NavPad is used. It automatically times out after approximately 30 seconds of inactivity.

A single press of any cursor keys will move it by 1 pixel in the direction of that key. Press and holding the cursor key will allow it to accelerate and move rapidly across the screen.

## 6.7 Transmit Legend

This is a small circle situated in the bottom right hand corner of the display, and informs the user about the transceiver status.

When the AI50 starts to transmit your vessels data, the transmit legend will turn green for 1 second. If there is an internal fault it will turn red, with an indication of the fault, all other times it will be white.

## 6.8 Vessel Information

The AI50 is able to view information from any AIS equipped vessel in

your VHF range.

### 6.8.1 Own Vessel

Press and hold the **INFO/STATUS** key for 2 seconds, the display changes to show your own vessels information in a panel on the right side of the screen. Fig. 6.4.

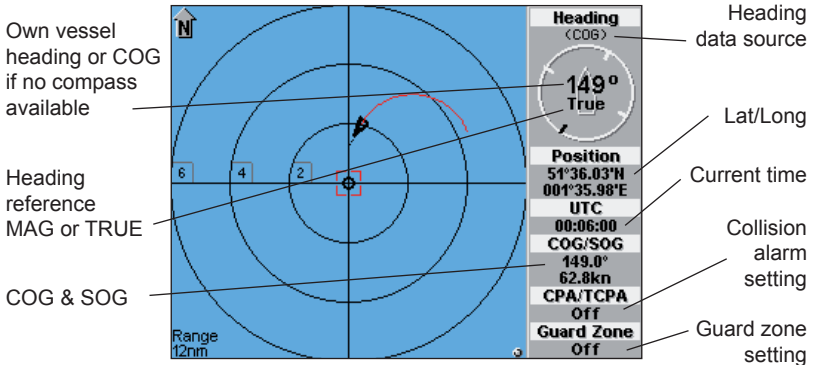

Fig. 6.4 – Own Vessel Information

To return to Full Screen View, press and hold the **INFO** key for another 2 seconds.

### 6.8.2 Other Vessel's Info (Reduced list)

Using the **▲▼◀▶** keys, place the cursor on the selected vessel, a highlighted box will appear. Press the **INFO** key once, the display changes to show you a summary of that vessel's information Fig. 6.5.

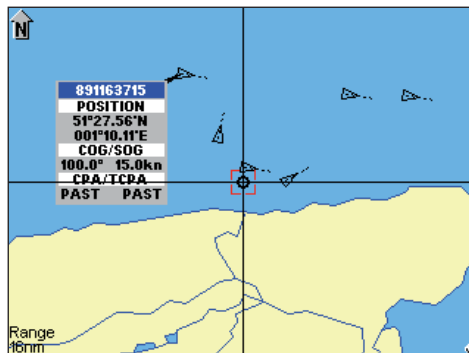

Fig. 6.5 – Shortened List

After approximately 10 seconds the list will change to the minimum and

display the vessel's name when available, otherwise it will display the MMSI number.

### 6.8.3 Other Vessel (Full list)

Press the INFO key a second time and you can view a full listing of the information relating to that vessel. Fig. 6.6

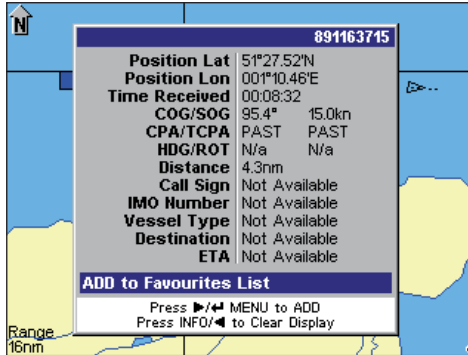

Fig. 6.6 – Full List

To enter this vessel into your “Favourites List” press ◀ MENU or ►.

To initiate a call to this vessel using a suitable DSC VHF Radio (If attached), press and hold the HOME/DSC key. Refer to section 6.10

### 6.8.4 Other Vessel (Minimal list)

Press the INFO key a third time and just the MMSI or name will be displayed. Fig. 6.7.

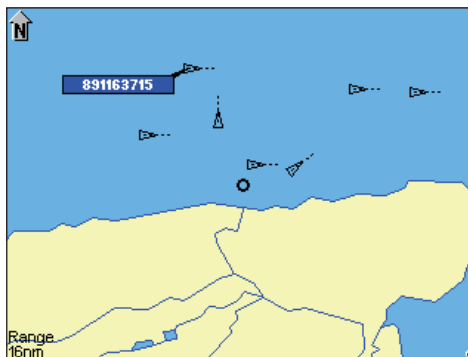

Fig. 6.7. – Vessels MMSI displayed

Pressing the INFO key a fourth time will return you to the AIS display.

## 6.9 General Rules for Vessel Information

As icons with dialogue boxes move across the display, they may overlap each other; if this is the case the current highlighted selected dialogue box will be the top one.

**Note** *If a lost vessel icon is selected, the only information displayed in the box will be the vessels MMSI, name and last received position.*

## 6.10 Making a DSC Call (In map mode)

To make a DSC call, the unit must be connected to a SimNet compatible DSC VHF radio.

In Display Mode highlight a vessel icon then press and hold the **HOME/DSC** key, the AI50 will format a Routine Individual DSC call. A “Creating DSC Call” window opens showing the MMSI number and name of the vessel you intend to call.

If this is correct and you wish to continue, press **← MENU** or **▶** to send the call. The “Routine DSC Call” window opens confirming that the call has been created and sent to the VHF radio.

If you wish to cancel the DSC call at this stage, press the **◀** key and the display will return to the map view.

If the AI50 is not connected to a compatible VHF radio when the DSC key is pressed a message window will open indicating that a compatible VHF radio cannot be detected.

Press the **◀** key to return to the map view.

**Note** *Further control for the DSC radio from this point must be done at the radio. For further information on the DSC functionality consult your radio’s user manual.*

## 6.11 Text Mode

To enter Text Display Mode, from the Map view, press and hold the **VIEW/DISPLAY** key. The screen will change as shown Fig.6.8.

Displaying 10 Ships, Sorted by Speed			
MMSI/NAME	POS LAT	POS LON	UTC
106344109	51° 21.66' N	000° 57.30' E	00:07:44
407456188	51° 30.60' N	001° 00.94' E	00:07:44
SHAMROCK	51° 24.32' N	001° 13.65' E	00:07:44
OSPREY	51° 23.92' N	001° 15.86' E	00:07:44
THIRSTY ...	51° 25.31' N	001° 07.75' E	00:07:44
891163715	51° 27.55' N	001° 10.15' E	00:07:44
476192636	51° 26.78' N	001° 22.48' E	00:07:44
213504917	51° 30.09' N	001° 16.13' E	00:07:44
391258710	51° 26.85' N	001° 19.16' E	00:07:44
BUBBLES	51° 25.41' N	001° 12.15' E	00:07:44

Press ▲▼ to Select, ◀▶ to Scroll, VIEW to Sort, Hold DSC to Call

Fig.6.8 – Text Mode

At the top just under the title bar are the Data Headings these are:

- MMSI/NAME
- COG
- SOG
- DISTANCE
- CPA
- TCPA
- POS LAT
- POS LON
- UTC
- HDG
- ROT
- CALLSIGN
- IMO No
- TYPE
- DEST
- ETA

Each consecutive line below the headings holds the voyage static data for a vessel within VHF range. Because this information does not fit on the screen, use the ◀▶ keys to scroll across the page, and use the ▲▼ to scroll down the page.

### 6.11.1 Changing the Sort Order

To change the display order in which the vessels are sorted, press the VIEW key, this will cycle through the following sort order:

- Sort by Acquire Time
- Sort by Distance (Closest first)
- Sort by TCPA/CPA (shortest time first)
- Sort by Speed (Fastest first)
- Sort by Vessel Name (alphabetical)

## 6.12 Making a DSC Call (In text mode)

To make a DSC call to a highlighted vessel use the same method as that described in Section 6.10

To return to Map view, press and hold the **VIEW/DISPLAY** key again

## 6.13 Tracking Individual Vessels

To track a selected vessel, place the cursor over it to highlight it and press the **TRACK** key once. That icon will turn Bold and tracking will start immediately, (although a trail may not be noticeable until the vessel has moved sufficiently). Fig. 6.9.

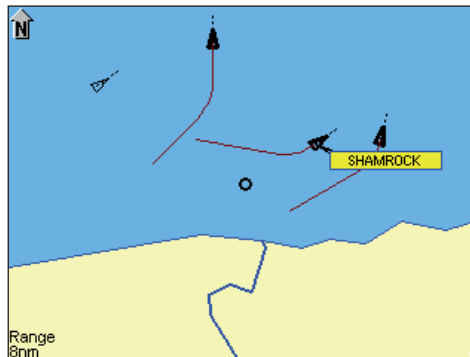

*Fig. 6.9 – Tracking individual vessels*

Multiple vessels can be tracked by selecting them using the above procedure.

To cancel individual tracking, select the vessel icon you wish to cancel and press the **TRACK** key. The vessel icon will return to its non-bold state and the existing trail will be cleared.

## 6.14 Tracking your own Vessel

To turn own vessel tracking on, place the cursor over your vessel to highlight it and press the **TRACK** key once. Your icon will turn red and bold, and tracking will start immediately, although a trail may not be

noticeable until your vessel has moved sufficiently Fig.6.10.

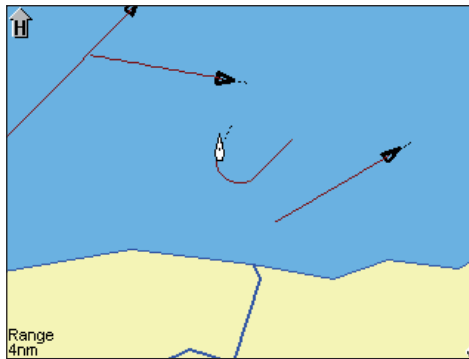

Fig. 6.10 - Tracking your own vessel

**Note** *If “Tracking Offset” is not active when you select “TRACK”, your vessel will be shown as a small circle at the centre of the display.*

*If “Tracking Offset” is already active when you select “TRACK”, your vessel will be shown as a distinctive boat icon at its current GPS location on the display, See section 5.5.2.*

## 6.15 Clearing Down All Trails

To clear all existing vessel trails, including your own vessels, press and hold TRACK (CLR TRK) for 2 seconds.

All vessels will return to their non-bold state and all tracks will be cleared from your display.

## 6.16 Light Adjustment (Short Cut)

Single presses of the  key will cycle through the preset lighting levels for both the keypad and display. (100% to off in 20% steps).

The current backlighting settings will be stored when the AI50 is powered down.

For further lighting options refer to section 5.3.1.

## 7 ALARMS

### 7.1 General

This section details the types of visual alarms, alerts and warnings used by the AI50. All alarm windows will have a hazard symbol displayed in the title bar.

All alarms relating to another vessel will display the following information about that vessel when triggered:

- MMSI
- Ships Name
- Latitude
- Longitude
- UTC
- Bearing
- COG
- SOG
- CPA
- TCPA

Each alarm state produced by the AI50 has an order of priority dependent on how serious the alarm condition is these are shown with their respective warning icon below:

 **Level 1** – is the highest priority alarm, which require immediate action. This alarm status if not acted upon with great urgency, could result in loss or serious damage to your vessel and /or loss of life.

 **Level 2** – high priority requires prompt attention. If this alarm status is not acted upon with some urgency, it could possibly develop into a “Level 1” Alarm resulting in loss or serious damage to your vessel and /or loss of life.

 **Level 3** – medium priority, and are reserved for warnings of a less urgent nature.

**Note** *All audible and visual alarms will remain until confirmed and cleared. If further alarms are activated before the current one is cleared, they will be stacked up and displayed in order of their priority, the highest priority being at the top.*

## 7.2 Collision Alarm – CPA/TCPA

This is a **Level 1** alarm. If you have activated the CPA/TCPA Alarm from within the Alarm Setup Menu, the CPA/TCPA is then calculated from the received position, COG and SOG of the AIS transmissions, from all AIS equipped vessels in your VHF range.

**Note** *CPA – “Closest Point of Approach” is the calculated distance of how close a vessel will pass.*

*TCPA – “Time to Closest Point of Approach” is the calculated time to reach the CPA.*

*The CPA/TCPA alarm values are set by the user, as described in section 5.5.1.1.*

### WARNING

***It is the responsibility of the user to determine how close another vessel may pass without being dangerous, and how quickly the user can react to manoeuvre their own vessel in order to avoid a collision.***

If both values calculated by the AI50 are less than, or equal to the values set by the user, then an alarm will activate, regardless of what screen the unit is in. An audible alarm will sound and a window will open displaying the following information Fig. 7.1.

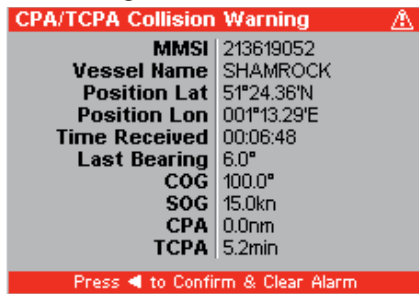

Fig. 7.1 – CPA/TCPA Alarm

Because this information is live, it is continuously being recalculated and updated.

To confirm and clear this alarm, press ◀, this will close the window and return you to current display.

The icon of the vessel which caused the alarm to activate will turn red, indicating an alarm condition still exists. Fig. 7.2.

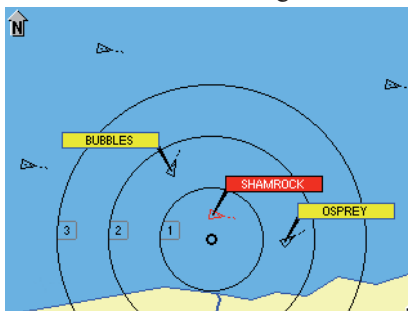

Fig. 7.2 – Collision Alarm view

### **WARNING**

***It is the responsibility of the vessel's captain to determine what action to take in this situation in order to avoid a collision.***

Once action has been taken, and the calculated values increase beyond the limits as set in the “Collision Alarm” menu, the vessel’s icon will return to its normal state.

## **7.3 Collision Alarm – Lost Vessel**

This is a **Level 1** alarm and will sound whether the Lost Vessel alarm as described in Section 5.5.2, has been set by the user or not.

If a vessel activates a CPA/TCPA or Guard Zone alarm, and the AIS transmissions from that vessel are lost; regardless of what screen the AI50 is in, an audible alarm will sound and a “Lost Vessel Collision Alert” window will open, displaying the last received information

To confirm and clear this alarm, press ◀, this will close the window and return you to current display.

The icon of the vessel which caused the alarm to activate will change to a “Lost Vessel” icon, (refer to section 6.2). It will retain its previous colour and bold outlines, and flash at a rate of once every second, indicating that this condition still exists.

The icon will remain on the display in this state for 10 minutes before

being erased. However, if reception from the lost vessel’s AIS is re-established, the icon will return to its previous state.

### 7.4 Collision Alarm – Guard Zone

This is a **Level 2** alarm. The guard zone is determined by the radius dimension entered by the user, as described in Section 5.5.1.2, and a red circle will surround your vessel. The size of this circle will be dependent on the display range selected.

**Note** *If “Track Own Vessel” mode has been activated; the red circle will track with your own vessel’s icon.*

For every AIS equipped vessel entering your Guard Zone, an audible alarm will sound, regardless of what screen the AI50 is in and a “Guard Zone Collision Warning” window will be displayed. Fig. 7.3

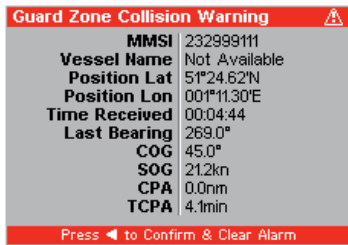

Fig. 7.3 – Guard Zone Warning

To confirm and clear this alarm press the MENU key. The icon of the vessel which caused the alarm to activate will turn red, indicating an alarm condition still exists.

Once a vessel leaves the Guard Zone its icon will return to the normal state.

### 7.5 BIIT Alarm

The BIIT (*Built In Integrity Test*) is a **Level 2** alarm.

The AI50 is constantly monitoring and testing the integrity of the AIS transceiver. Should a fault be detected within the unit, the small circle situated in the bottom right hand corner of the display flashes red, and a text message informs the user about the transceiver status.

The “BIIT” message will remain there until the fault is cleared by the

AI50 circuitry, or the unit has been repaired.

If the unit is powered down with a BIIT fault still active, the fault type will be saved to memory and displayed the next time the AI50 is turned on.

## 7.6 Lost Vessel Alarm

This is a **Level 3** alarm, and will be activated when the AIS reception from a vessel is lost.

An audible alarm will sound and a “Lost Vessel Alarm” window will open, displaying the last received information.

To confirm and clear this alarm, press ◀, this will close the window and return you to current display.

The icon of the vessel which caused the alarm to activate will change to a “Lost Vessel” icon, (refer to section 6.2). If the text display is active, the text line for that vessel’s data will be greyed out.

If reception from the lost vessel’s AIS is re-established, then the icon will return to its previous state.

## 7.7 Favourites Alarm

This is a **Level 3** alarm, and will only display if the option has been activated in the “Alarm Setup Menu”. If a vessel entered on your favourites list comes within your VHF range the following window will open and the alarm will sound. Fig. 7.4.

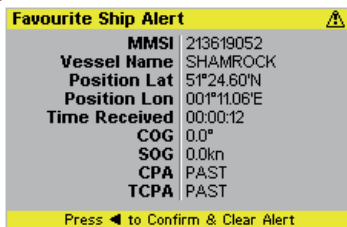

*Fig. 7.4 - Favourite ship alert*

To confirm and clear this alarm, press ◀, this will close the window and return you to current display.

## 7.8 Loss Of Compass Heading Data

This is a **Level 3** alarm, and will only activate if the SimNet/NMEA2000 data for the ships compass is lost.

An audible alarm will sound and a “Loss of Compass” alarm window will open showing details of the lost compass and any other compatible compass units on the network.

Using the ▲▼ select an alternative device and press the ← MENU key to select it.

If the ← MENU key has been pressed without selecting a new compass the unit will continue to operate without compass information and any displays consisting of the vessel’s own heading will be blank.

If “HDG Up” or “North Up” View Point mode is selected, it will be cancelled and the display View Point will change to “COG Up”.

If the original compass unit returns to the network this will automatically be re-selected, and a message window will appear to indicate this.

To confirm and clear this alarm, press ◀, this will close the window and return you to current display.

## 7.9 Safety Message Alarm

AIS technology incorporates a messaging system that allows approved users to broadcast safety messages that will appear as text in the AIS display.

This is a **Level 3** alarm, and will activate if a safety message is received from another vessel over the AIS network. An audible alarm will sound and a “Safety Message Alarm” window will open, displaying the received information and the safety message. An example is shown in Fig. 7.5.

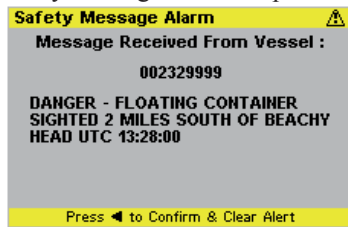

Fig. 7.5 – Example Safety Message

To confirm and clear this alarm, press ◀, this will close the window and return you to current display.



## 8 APPENDIX

### 8.1 Maintenance

Periodically wipe down the casing and display screen with a clean damp cloth.

To remove heavier marks add a small quantity of mild detergent to some water, dampen cloth and wring out thoroughly before wiping unit.

#### **WARNING**

***Never use cleaning solutions containing spirit or alcohol as these can damage the unit.***

### 8.2 Troubleshooting

These simple checks should be carried out before seeking technical assistance and may save time and expense.

General Symptom	Possible Cause	Remedy
Unit will not switch on	<ul style="list-style-type: none"> <li>Faulty connector to power</li> <li>Fuse has blown</li> </ul>	<ul style="list-style-type: none"> <li>Check power connection</li> <li>Replace fuse and check power supply</li> </ul>
No picture on display	<ul style="list-style-type: none"> <li>Unit not powered up</li> <li>Light level set too low</li> </ul>	<ul style="list-style-type: none"> <li>Press PWR/ key</li> <li>Increase light level. (See section 3.10 and 5.3.1)</li> </ul>
No mapping detail	<ul style="list-style-type: none"> <li>Coastline detail not active</li> </ul>	<ul style="list-style-type: none"> <li>Activate coastline detail (see section 5.2.1)</li> </ul>
No GPS Position data	<ul style="list-style-type: none"> <li>Antenna or cable problem</li> </ul>	<ul style="list-style-type: none"> <li>Check antenna cable and connections</li> </ul>
No HDG info	<ul style="list-style-type: none"> <li>SimNet cable problem</li> </ul>	<ul style="list-style-type: none"> <li>Check SimNet power/ connector</li> </ul>
Not logging	<ul style="list-style-type: none"> <li>No SD card</li> <li>Wrong type of SD card</li> </ul>	<ul style="list-style-type: none"> <li>Install SD card (see section 2.8)</li> <li>Install correct type SD card (see section 2.8)</li> </ul>
No AIS transmission	<ul style="list-style-type: none"> <li>MMSI not entered</li> <li>Transmit disabled</li> </ul>	<ul style="list-style-type: none"> <li>Enter MMSI number</li> <li>Enable Transmit (see section 5.6.7)</li> </ul>

## 8.3 Accessories

The following accessories are available from local Simrad agents:

VA14\*                    VHF AIS antenna - S/S whipwith 20m  
Cable, terminated in a PL259 plug.

\* One off required for operation

## 8.4 Product Specifications

### AIS Type

Class B for use on non-SOLAS craft

### VHF Receiver

Receiver type            Dual TDMA (shared DSC)  
Sensitivity                < -107dBm for 20% PER  
Transmit power          2Watt  
Type Approval            IEC62287-1

### GPS Receiver

Receiver type            Integral 16 channel receiver

### EMC

IEC60945

### Power

Voltage                    10.8 – 15.6VDC  
Current                    <1A  
SimNet/NMEA2000        Network load 1

### Backlighting

Keypad                    LED (Red or White)

### Display Type

VGA TFT                    102mm (4in)

### Connectors

VHF Antenna PL259  
GPS Antenna                SMB

### Physical

With Bracket 201mm (7.9") x 133mm (5.2") x 77mm (3")  
Without Bracket          172mm (6.8") x 115mm (4.5") x 77mm (3")  
Weight                     1Kg

### Environmental

Waterproofing            IP67  
Temperature range        -15°C to +55°C

### Interfaces

#### NMEA0183

Out                         38kbaud    VDM, VDO, RMC, ALR  
In                            38kbaud    for configuration & testing only

**SimNet/NMEA2000 PGN's**

## NMEA2000 Mandatory PGNs

59392 ISO Acknowledgment  
59904 ISO Request  
60928 ISO Address Claim  
126996 NMEA2000 Product Information

## NMEA2000 Data PGNs

126992 System Time  
129025 Position, "Rapid Update"  
129026 COG & SOG, "Rapid Update"

## NMEA2000 AIS PGNs

129038 Class A Position Report  
129039 AClass B Position Report  
129040 Class B Extended Position Report  
129792 DGNSS Broadcast Binary Message  
129793 UTC and Date Report  
129794 Class A Static and Voyage Related Data  
129795 Addressed Binary Message  
129796 Acknowledge  
129797 Binary Broadcast Message  
129798 SAR Aircraft Position Report  
129800 UTC/Date Enquiry  
129801 Addressed Safety Message  
129802 Broadcast Safety Message  
129803 Interrogation  
129804 Assignment Mode Command  
129805 Data Link Management Message

## Simrad/SimNet Proprietary PGNs

130844 Bluetooth Control  
65323 Group Setup Message  
130840 DataUserGroup Configuration  
65332 Remote Control  
61184 Simrad/SimNet Parameter command  
65480 Simrad/SimNet Parameter reply  
130842 AIS & VHF Message Transport

## 8.5 Dimensions

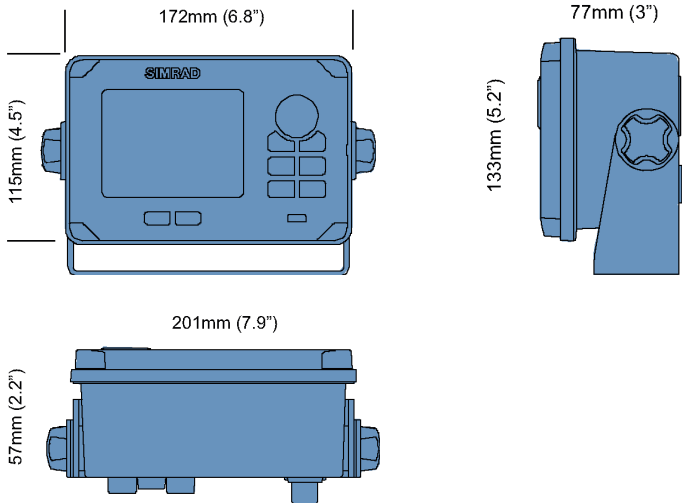

8.1 - AI50 dimensions

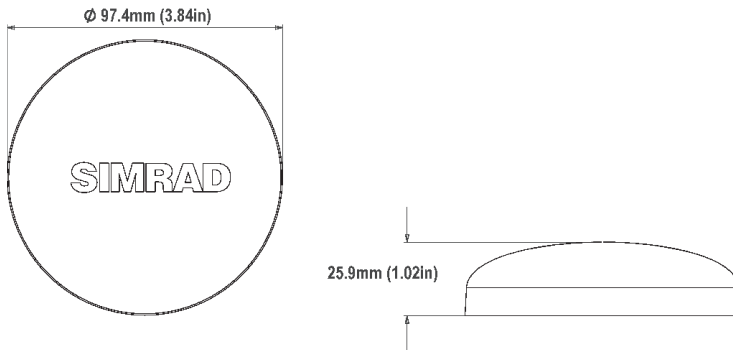

8.2 - AI50 GPS Antenna dimensions

## 8.6 Service and Warranty

If it is necessary to have a unit repaired, please contact your local authorized dealer. For worldwide warranty details and a list of authorised Simrad agents please refer to the Warranty Card supplied with this unit.

## 8.7 Declaration of Conformity (EU)

	English	Hereby, Simrad Limited (Margate) declares that this AI50 is in compliance with the essential requirements and other relevant provisions of Directive 1999/5/EC.
	Finnish	Simrad Limited (Margate) vakuuttaa täten että AI50 tyyppinen laite on direktiivin 1999/5/EY oleellisten vaatimusten ja sitä koskevien direktiivin muiden ehtojen mukainen.
	Dutch	Hierbij verklaart Simrad Limited (Margate) dat het toestel AI50 in overeenstemming is met de essentiële eisen en de andere relevante bepalingen van richtlijn 1999/5/EG.
	French	Par la présente, Simrad Limited (Margate) déclare que ce AI50 est conforme aux exigences essentielles et aux autres dispositions de la directive 1999/5/CE qui lui sont applicables.
	Swedish	Härmed intygar Simrad Limited (Margate) att denna AI50 står i överensstämmelse med de väsentliga egenskapskrav och övriga relevanta bestämmelser som framgår av direktiv 1999/5/EG.
	Danish	Undertegnede Simrad Limited (Margate) erklærer herved, at følgende udstyr AI50 overholder de væsentlige krav og øvrige relevante krav i direktiv 1999/5/EF.
	German	Hiermit erklärt Simrad Limited (Margate), dass sich dieses AI50 in Übereinstimmung mit den grundlegenden Anforderungen und den anderen relevanten Vorschriften der Richtlinie 1999/5/EG befindet. (BMW i)
	Greek	Με την παρούσα Simrad Limited (Margate) δηλώνει ότι AI50 συμμορφώνεται προς τις ουσιαστικές απαιτήσεις και τις λοιπές σχετικές διατάξεις της οδηγίας 1999/5/EK.
	Italian	Con la presente Simrad Limited (Margate) dichiara che questo AI50 è conforme ai requisiti essenziali ed alle altre disposizioni pertinenti stabilite dalla direttiva 1999/5/CE.
	Spanish	Por medio de la presente Simrad Limited (Margate) declara que el AI50 cumple con los requisitos esenciales y cualesquiera otras disposiciones aplicables o exigibles de la Directiva 1999/5/CE.
	Portuguese	Simrad Limited (Margate) declara que este AI50 está conforme com os requisitos essenciais e outras provisões da Directiva 1999/5/CE.

Website – [www.simradyachting.com](http://www.simradyachting.com)

