

Manual

Simrad DD15 Direct Drive

English

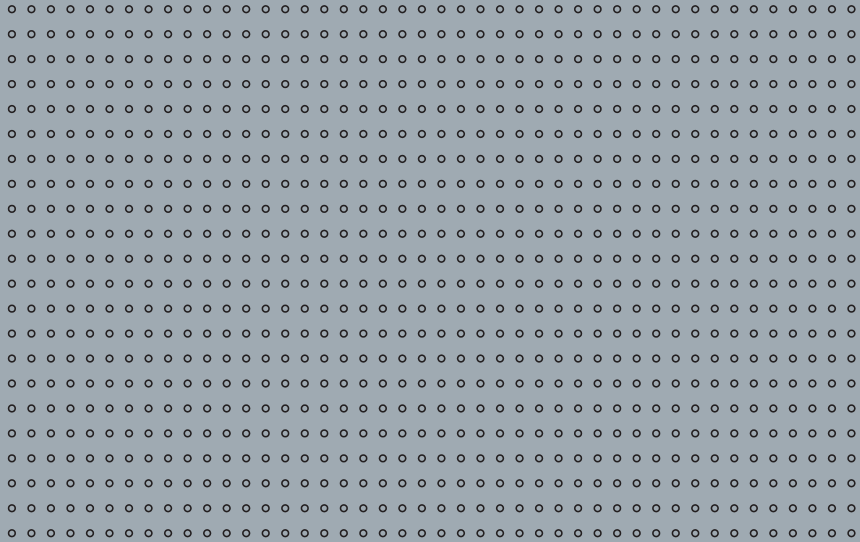

MANUAL

SIMRAD DD15

Direct Drive

20222303A

English

About this document

Rev	Date	Written by	Checked by	Approved by
A	06.04.06	NG	IK	ThH
First edition				

© 2006 Simrad AS. All rights reserved.

No part of this work covered by the copyright hereon may be reproduced or otherwise copied without prior permission from Simrad AS.

The information contained in this document is subject to change without prior notice. Simrad AS shall not be liable for errors contained herein, or for incidental or consequential damages in connection with the furnishing, performance, or use of this document.

Contents

1	SYSTEM DESCRIPTION	5
1.1	General.....	5
1.2	How to use this manual.....	6
1.3	Performance	7
1.4	Compatibility in 12 Volts.....	8
2	CONSTRUCTION	9
2.1	Electric Motor	9
2.2	Planetary gearbox.....	9
2.3	Electro magnetic clutch.....	10
3	INSTALLATION	11
3.1	Mechanical mounting.....	11
	Reducing noise and vibrations	12
	Feedback unit mounting.....	13
	Direct drive in combination with rack and pinion system	15
	Direct drive in front of pedestal	17
3.2	Electrical connections	18
3.3	Test the system.....	19
4	MAINTENANCE	20
5	TECHNICAL SPECIFICATIONS	21
	Draglinks	22
	Spare Parts.....	22

This page is intentionally left blank

1 SYSTEM DESCRIPTION

1.1 General

The DD15 Direct Drive is a very strong and compact autopilot drive and more efficient than hydraulic and most electro-mechanical autopilot drive units. It is powerful (the max. output torque of 150 Kgm is equivalent to 150 Kg force on the end of a 1 meter steering tiller) and is build for 24 hours per day continuous operation with a total weight of only 12 Kgs. The combination of the flat wound (pancake) electric motor with the efficient planetary and spur gearbox results in an extremely efficient drive unit to keep the battery charging time to the minimum. The drive can be used on boats from 30 to 45 feet l.o.a. (or up to 150 Kgm rudder torque) equipped with a mechanical steering system that can be back driven. Due to the electro mechanical clutch, the direct drive can be back driven with the force of a finger tip leaving the mechanical steering as sensitive as without drive unit.

The DD15 includes the Simrad RF300 Rudder Feedback unit with transmission link and 10 m (30 feet) of cable. It transforms the angular travel of the rudder to a digital signal read by the autopilot steering computer.



Figure 1-1 Simrad DD15 Direct Drive (with RF300)

1.2 How to use this manual

This manual is intended as a reference guide for correctly installing the Simrad DD15 Direct Drive.

Please take time to read the manual to get a thorough understanding of the use of the drive and the connection to an autopilot system.

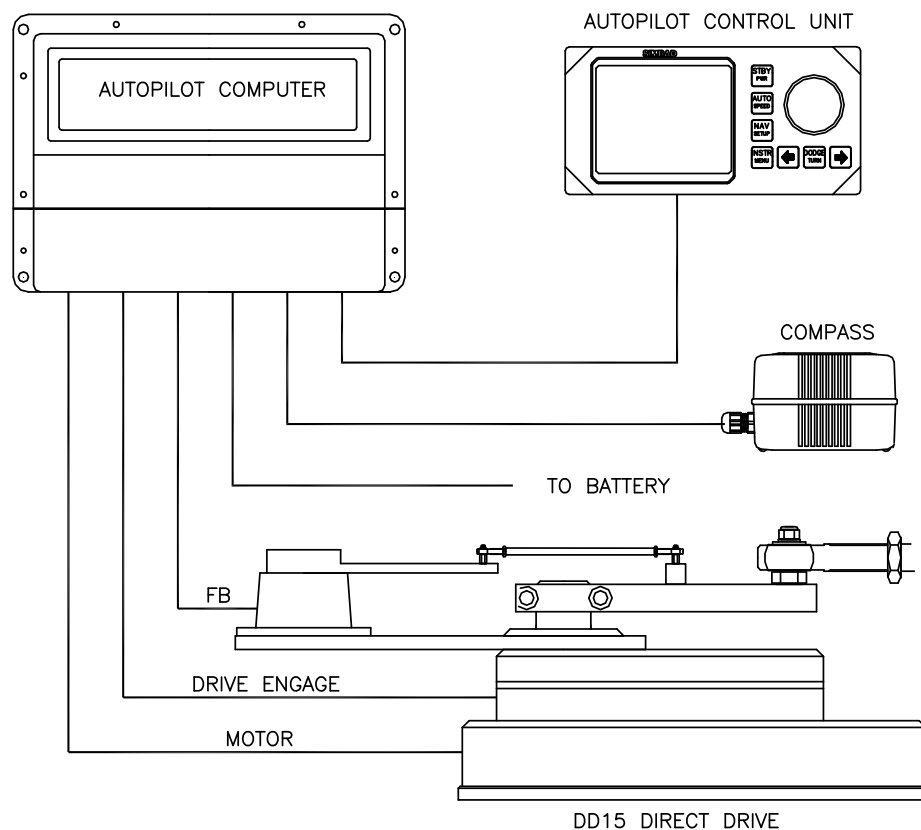

Figure 1-2 Basic autopilot system

This illustration shows the minimum number of components for a working autopilot configuration.

1.3 Performance

The performance table shows the relation between the consumed power and the output power. The “rudder torque midships” line shows the output torque against the needed amperage at midships rudder and the “rudder torque full rudder” line shows the output torque against the needed amperage at full rudder. The “hard over time” line shows the hard over time (time to travel 72° of rudder travel) of the drive relative to the output torque. The table also presents the strength of the drive unit related to man power. The unit is much stronger than a human being and can last much longer. One should note however that when the unit is operated in the dark grey zone, the trim of the boat is not at its best and the sails should be adjusted to achieve lower rudder torques. The below table shows that the Simrad direct drive will steer the yacht even in the worst possible conditions. As the drive will mostly operate in the light grey zone but not continuously, the average power consumption on 12 volts is 2 amps.

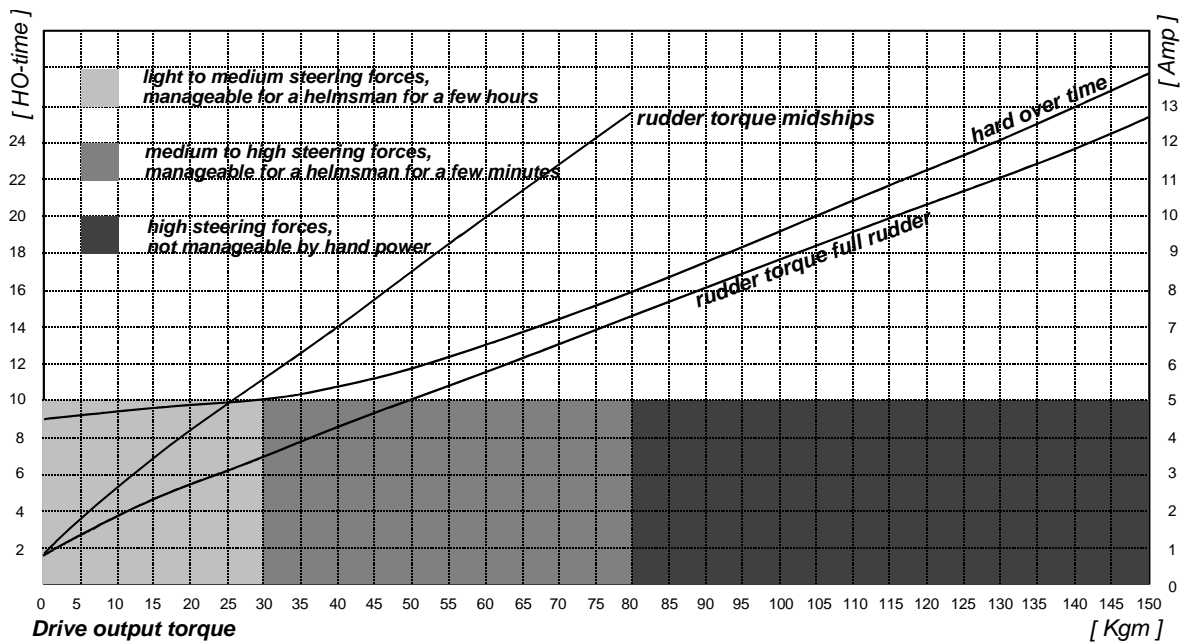

Figure 1-3 DD15 Direct Drive performance table

1.4 Compatibility in 12 Volts

The following table shows the maximum rudder torques at amidships and full rudder that can be achieved with the Simrad direct drive in combination with the autopilot computer. The hard over time (HO-time) states the time it takes the drive to travel the full 72 degrees of rudder travel when the speed control of the autopilot is set to maximum speed.

Autopilot computer 12 Volt version.	Max. Output (Amp.)	Rudder torque amidships (Kgm)	Rudder torque full rudder (Kgm)
Simrad AC10 (J3000X)	12	73	140
Simrad AC20 (J300X)	20	80	150

Note *Even if the AC10 Autopilot Computer is capable of driving the unit almost to its full power, the AC20 version will have the necessary extra power when the unit is operating to its extremes.*

2 CONSTRUCTION

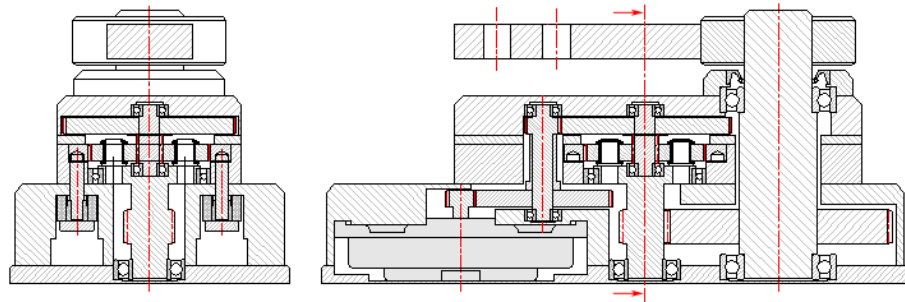

This assembly drawing shows a cross section of the direct drive. The drive can be separated in 5 main parts: The electric motor, the two step spur gearbox, the planetary gearbox, the electro-magnetic clutch and the final spur reduction gearbox. The Simrad direct drive has multiple advantages over existing integrated drive units. These advantages will be explained per section of the drive:

2.1 Electric Motor

The flat wound electric motor (pancake motor) used in the Simrad direct drive is carefully selected for this application. Pancake motors have multiple advantages over normal electric DC motors:

- A large flat wound rotor to achieve a high starting torque and an immediate response to the autopilot speed control signal.
- A motor efficiency of 72,5% to achieve a minimal power consumption and maximal mechanical power output (compared to max. 50% efficiency of a normal DC motor).
- Compact main dimensions compared to achievable output.
- Aluminum motor housing in stead of sheet steel plate to avoid corrosion.

2.2 Planetary gearbox

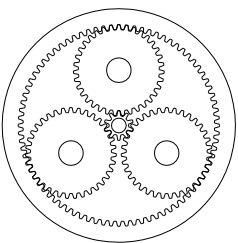

To achieve a correct rudder travel speed (hard over time) the electric motor has to be reduced in speed with a factor 750:1. Some autopilot drive producers use a worm reduction box, but the efficiency is extremely low as the gears rub each other. The Simrad direct drive uses a combination of a planetary gearbox and spur gear sets (one small gear and one big gear). The planetary gearbox has following advantages:

- The highest possible efficiency compared to any other gearbox.
- All forces are equally spread over 3 gear teeth in stead of one allowing a much compacter and stronger solution.
- The forces and torques from the motor to the output shaft remain in the center line of the drive unit, resulting in a higher efficiency and extremely reduces the loads on the housing and other internal parts.

2.3 Electro magnetic clutch

On the moment the mechanical steering system on the yacht is manually operated, the autopilot drive has to be disconnected from the steering system. This is achieved with the unique and patented electro-magnetic engagement clutch, controlled automatically by the autopilot computer. The solution is based on two electrically operated spring loaded clutch pins that engage and disengage the outer gear ring of the planetary gear step. This solution has multiple advantages over the existing friction plate clutches:

- Less friction to back drive the unit.
- Lower power consumption (1.2 Amp. at 12 Volt). When the clutch is not powered, it is disengaged.
- The clutch doesn't wear in time.
- More compact than any friction clutch.
- When the autopilot is switched off, the helmsman is not suddenly confronted with the full rudder torque, but has to put load on the wheel to equalize the forces so the clutch can disengage, making the manual take over much safer.

3 INSTALLATION

3.1 Mechanical mounting

The direct drive drives the rudder via a draglink to the existing tiller lever or quadrant or via a separate tiller lever. The length of the draglink and a separate tiller lever (if necessary) have to be specified when ordering. See the Direct Drive Specification Form (page 23) for available draglink lengths and tiller levers. The draglink part numbers are listed on page 22.

The drive can be mounted behind or next to the rudderstock, driving the rudder directly or in front of the pedestal driving the rudder via the pedestal.

The direct drive comes as standard with a 16 mm pin 165 mm from the center of the output lever. The pin can be moved to the 130 mm position from the center, but must be secured with Loctite.

The direct drive uses “wide angle geometry”. The result of this is a 130° travel of the output lever and a 72° travel of the tiller lever(see Figure 3-2). To achieve an equal travel of the drive at port and starboard, the center point of the output lever needs an offset to the rudderstock centre. The offset depends on the used lever centers. Following table shows the correct offset distances:

Operating centers in mm valid for 72° (2x36°) rudder travel.		
Output center	Offset distance	Tiller center
130	106	200
165	127	250

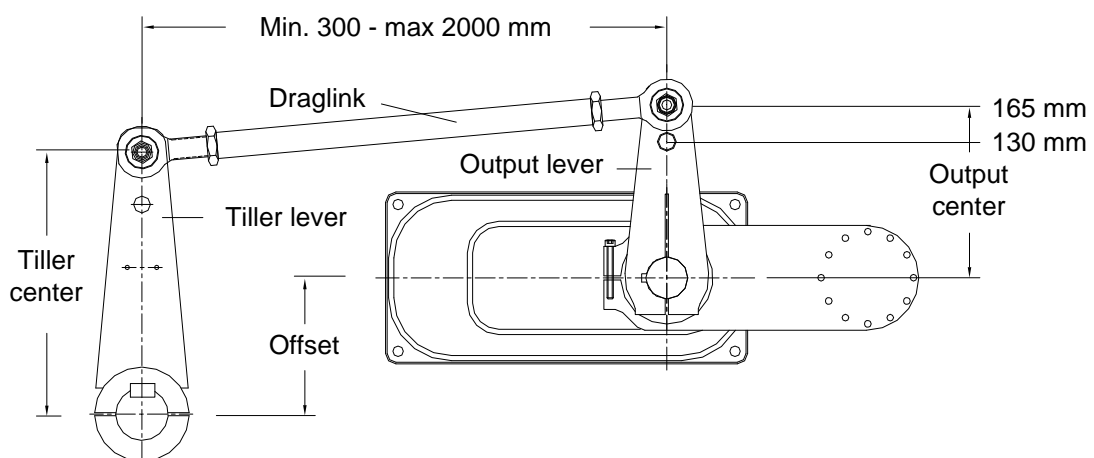

Figure 3-1 Mechanical mounting

A good installation check is to make sure that all end position points for the output lever and the tiller lever are in one line.

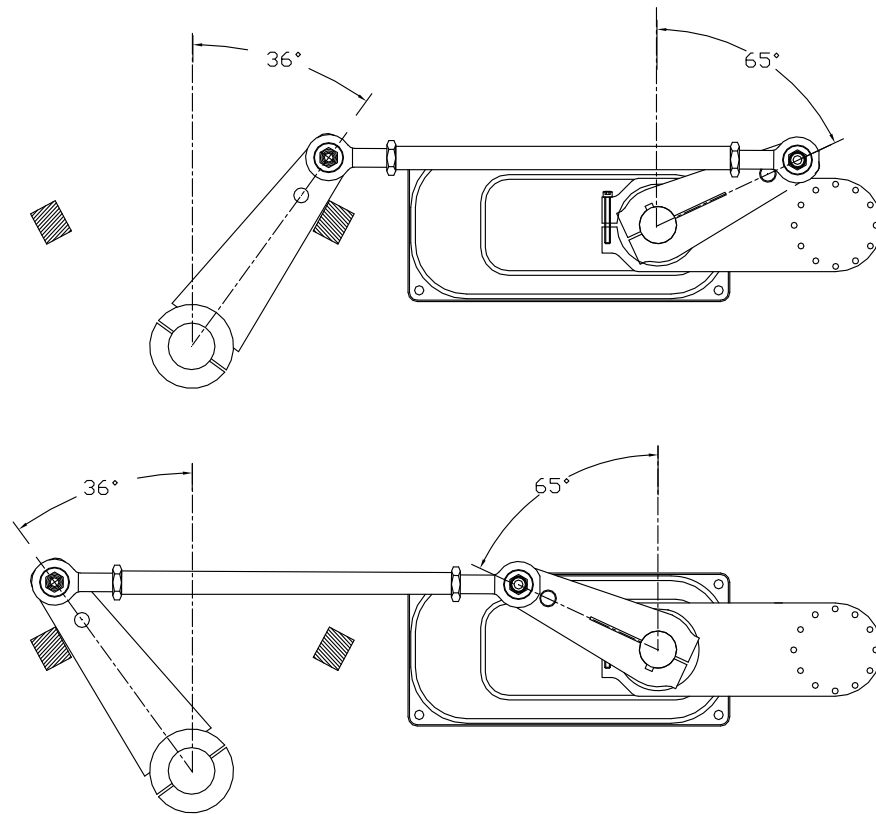

Figure 3-2 Travel of tiller lever and output lever

Reducing noise and vibrations

The vibrations from the autopilot drive motor and gears are often amplified multiple times by the deck or hull. This noise can be dramatically decreased by using the special bolts, rubber washers and bushes one can find in the bag supplied with the drive unit. When mounted like in the below illustration, the vibrations will be limited to the absolute minimum and a smooth and silent installation is guaranteed.

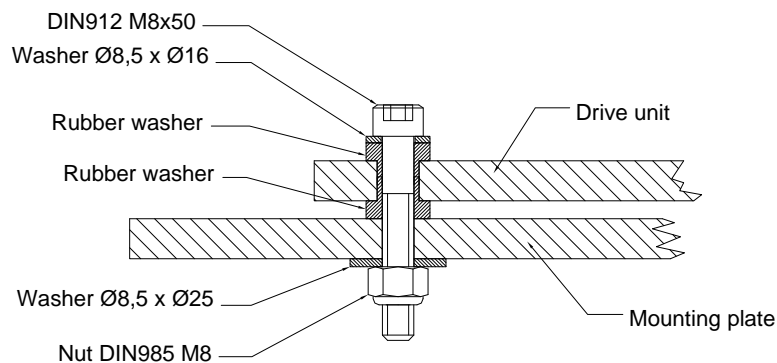

Figure 3-3 Reducing vibrations

Feedback unit mounting

Attached to the direct drive is a mounting bracket for the rudder feedback unit. The feedback unit and transmission link with mounting screws are supplied with the direct drive.

- Set the rudder to amidships position.
- Clamp the feedback bracket to the direct drive with a 90° angle to the output lever.
- Set the feedback transmitter lever to center position by means of the alignment marks.
- Attach the feedback unit to the bracket by using the supplied screws. With the rudder in amidships position make sure the transmitter lever and the output lever is in parallel and pointing in the same direction.
- Attach one end of the transmission link to the output lever.
- Attached the other end to the transmitter lever slot and make sure the link is in parallel with the mounting plate.

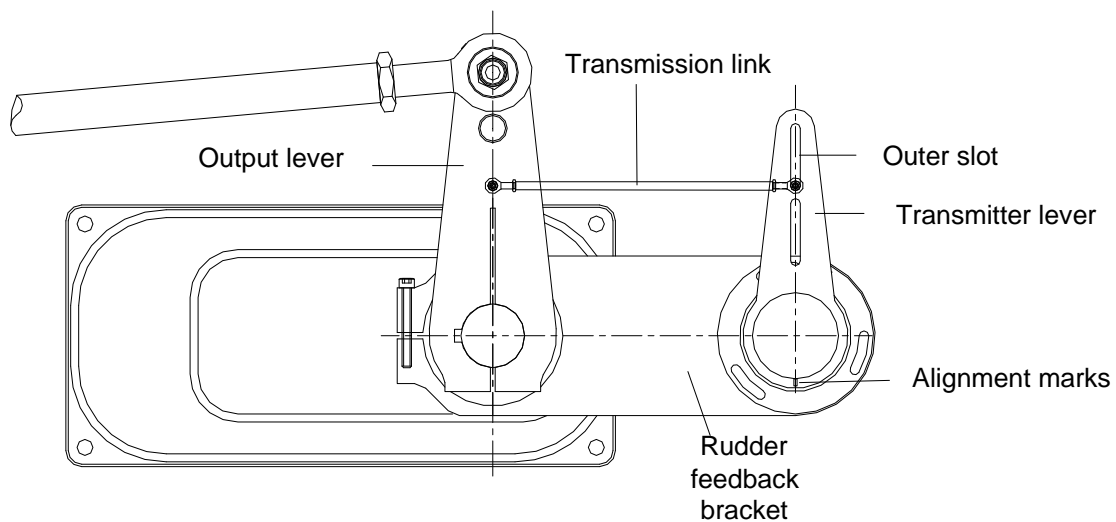
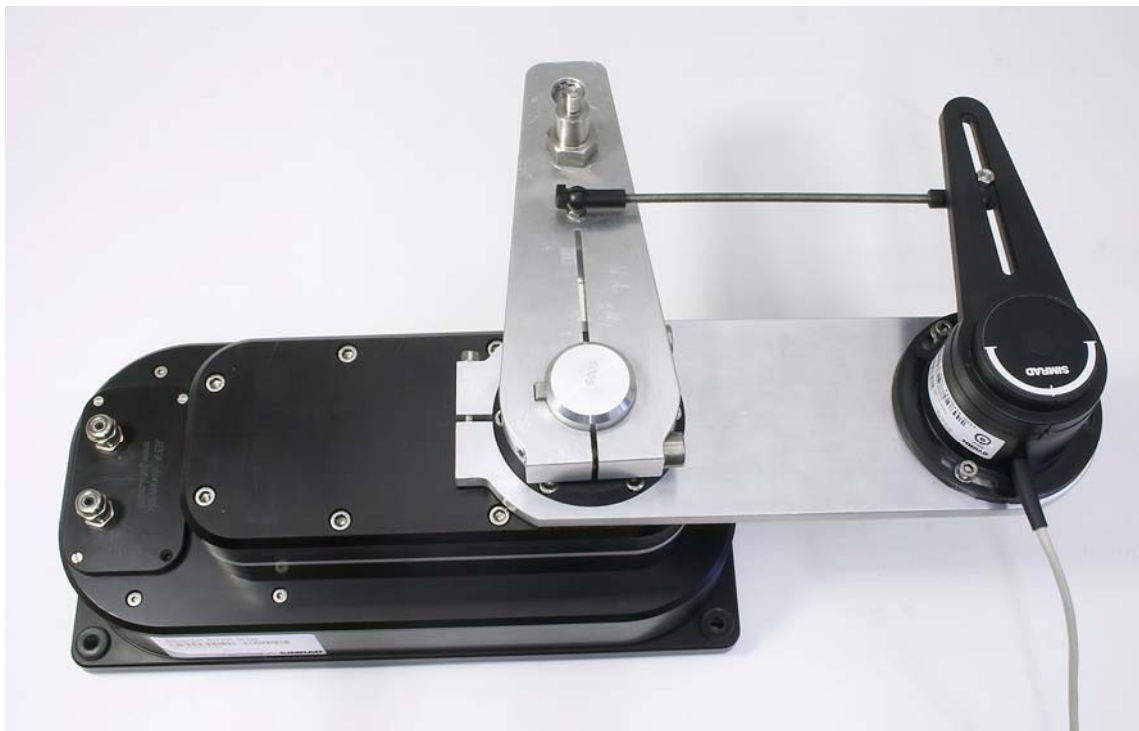

Figure 3-4 Feedback unit mounting

Examples of DD15 Mounting



Direct drive in combination with rack and pinion system

In principle the installation in combination with a rack and pinion system is the same as the standard installation except for the fact that the complete setup is rotated with the steering offset angle β .

First install the rack and pinion system with the correct geometry, put the rudder amidships and find the line perpendicular to the tiller lever center line. Put the drive on a parallel line with an offset distance as in below table. Rotate the drive lever to the same offset angle as the steering system offset angle β and mount the draglink.

Operating centers in mm valid for 72° (2x36°) rudder travel.		
Output center	Offset distance	Tiller center
130	106	200
165	127	250

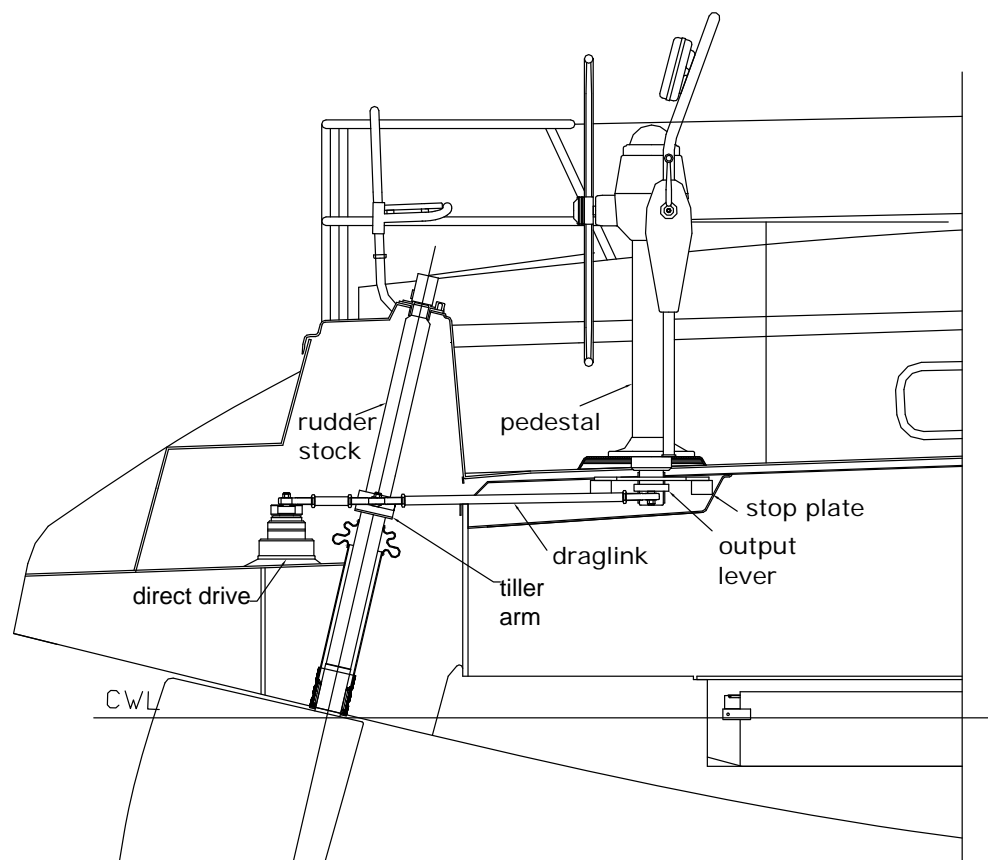

Figure 3-5 Drive unit in combination with rack and pinion system - side view

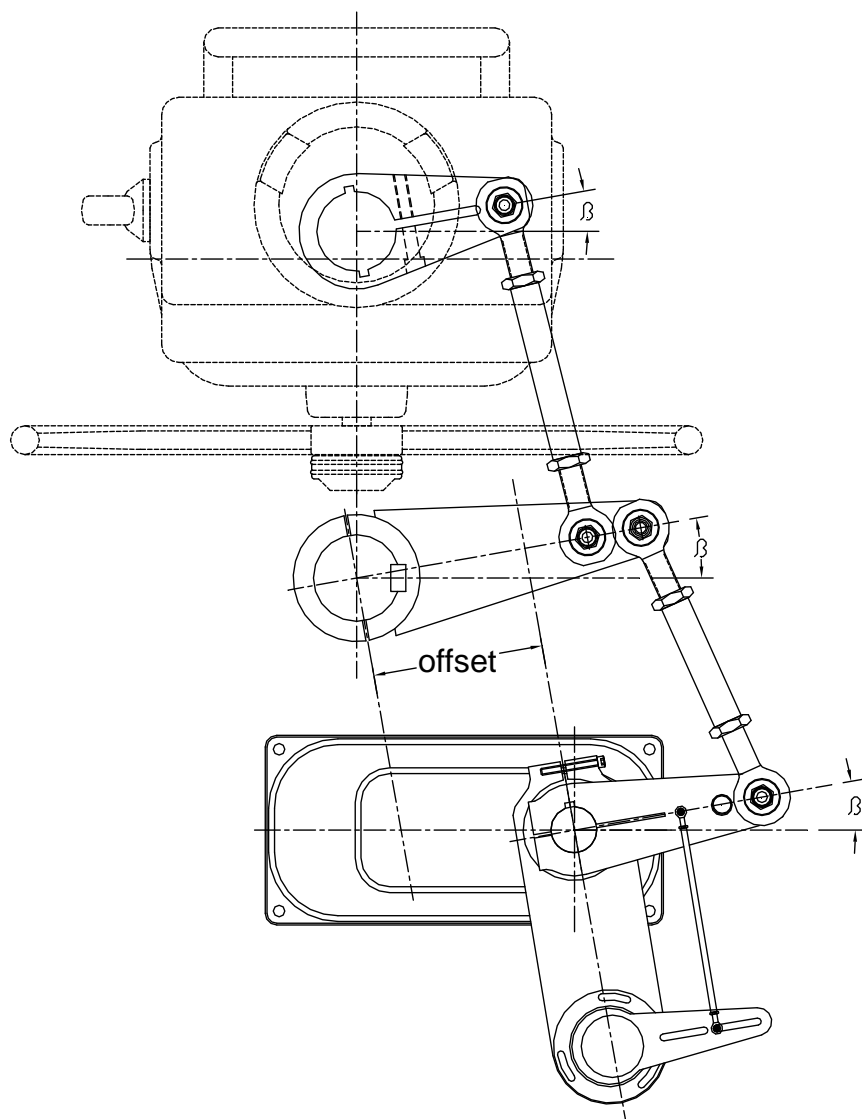

Figure 3-6 Drive unit in combination with rack and pinion system – top view

Direct drive in front of pedestal

When sufficient space around the rudder shaft isn't available, the direct drive can be setup to drive the rudder via the pedestal.

An extra extended output lever with 165 mm centers can be fitted to the pedestal down-shaft to be driven by the direct drive.

The lever geometry between the drive and pedestal is a parallelogram of 165 mm. The pedestal offset angle has to be respected, so the whole parallelogram is rotated around the pedestal center with the offset angle.

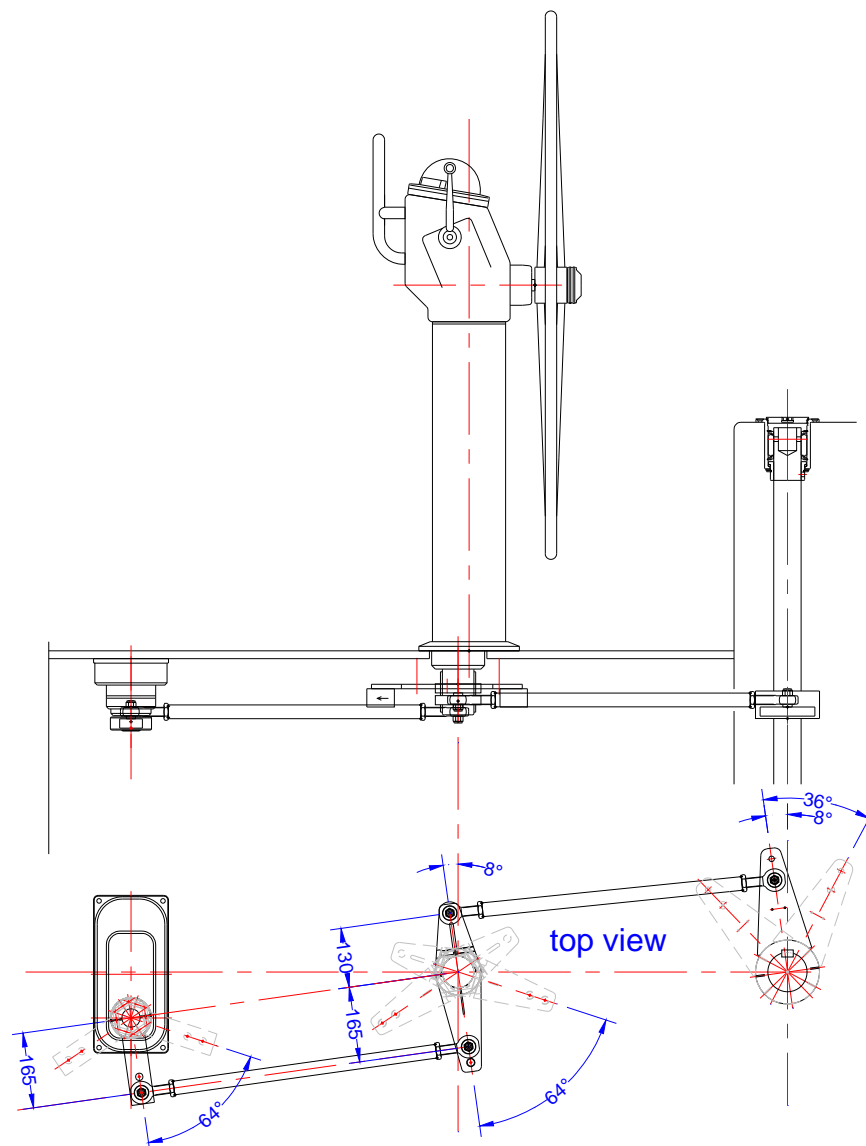

Figure 3-7 Drive unit in front of pedestal

3.2 Electrical connections

The connection of the Simrad direct drive to the autopilot computer is quite simple. The two 0.75 mm² red and black wires for the clutch have to be connected to the plus and minus of the autopilot clutch Drive Engage terminals. This will make sure that when the autopilot user engages the autopilot on the control unit, the clutch will engage and allow the autopilot motor to drive the steering system. The two heavy 2 mm² red and black wires have to be connected to the Solenoid – Motor terminals.

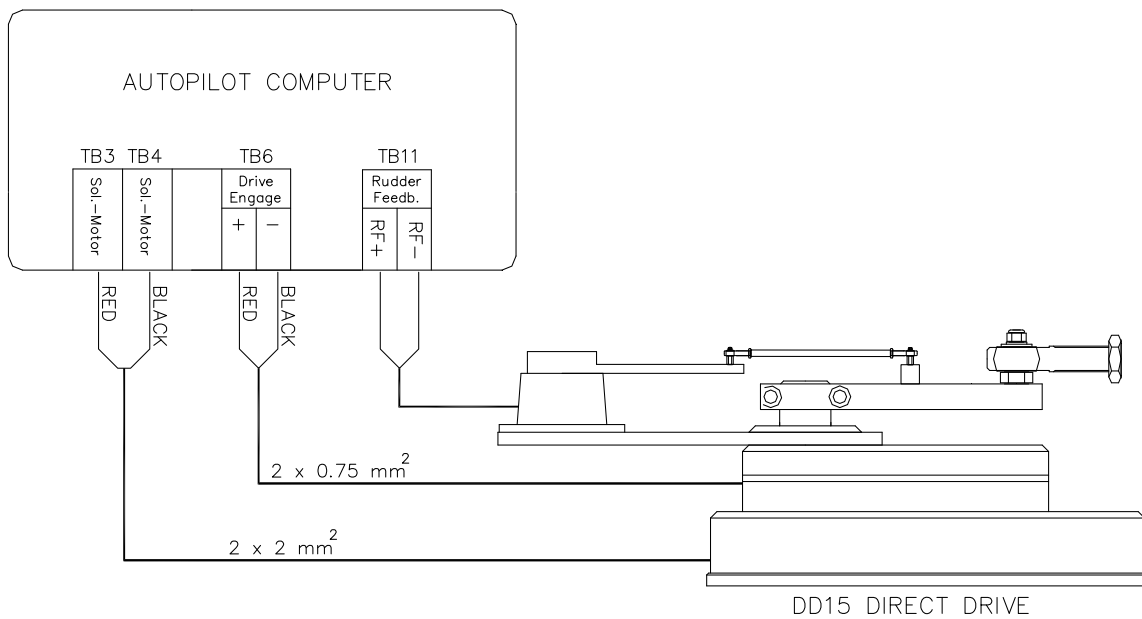

Figure 3-8 Autopilot connection

3.3 Test the system

Before you can test the system, make sure following things are correct:

- Solid rudder stops should be fitted limiting the rudder travel to an equal travel of 36 degrees from amidships to port and starboard.
- Make sure all bolted parts (tiller pins, rose joints, draglinks, tiller arm, feedback, transmission link, etc) are firmly tightened and will not come loose even when exposed to heavy vibrations. Use Loctite when necessary.
- Move the complete system from port to starboard making sure the rose joints don't hit the output lever and tiller lever.
- Make sure the drive output lever rotates equally approximately 65 degrees to both sides and there is no risk for the output lever to pass "over dead centre" so it can't return to the initial position any more, blocking the system.

Refer to the autopilot manual and perform the rudder calibration and test.

Note

Even if the ratio between the output lever of the drive unit and the rudder tiller is not linear, follow the instructions as written.

If the drive doesn't react to the electronics, test the drive by bypassing the electronics: Connect a plus and minus wire to the battery or fuse box and first connect the clutch, one should hear a click when connecting and disconnecting. With the clutch under power, connect power for a short time to the motor cables. The system should get in motion now. Don't connect the cables too long as the drive will try to continue, even when the rudder stops are reached, with potential damage to the structure. If motion is detected, one can rule out the drive causing the malfunction.

4 MAINTENANCE

The direct drive is “greased for life”, so it should not be opened. No maintenance is required except for periodic checks of all bolted connections. As the rudder system, the steering system and the autopilot drive are exposed to heavy vibrations (mainly by cruising on motor), all bolted connections should be yearly checked. The only parts that could wear in time are the ball joints in the draglink. These are easily exchangeable and available from Simrad.

5 TECHNICAL SPECIFICATIONS

Dimensions:.....	See <i>Figure 5-1</i>
Weight:.....	12 Kg (26.5 lb.)
Motor voltage:.....	12V
Clutch voltage:.....	12V
Average power consumption:.....	2 Amps
Output torque:.....	150 Kgm

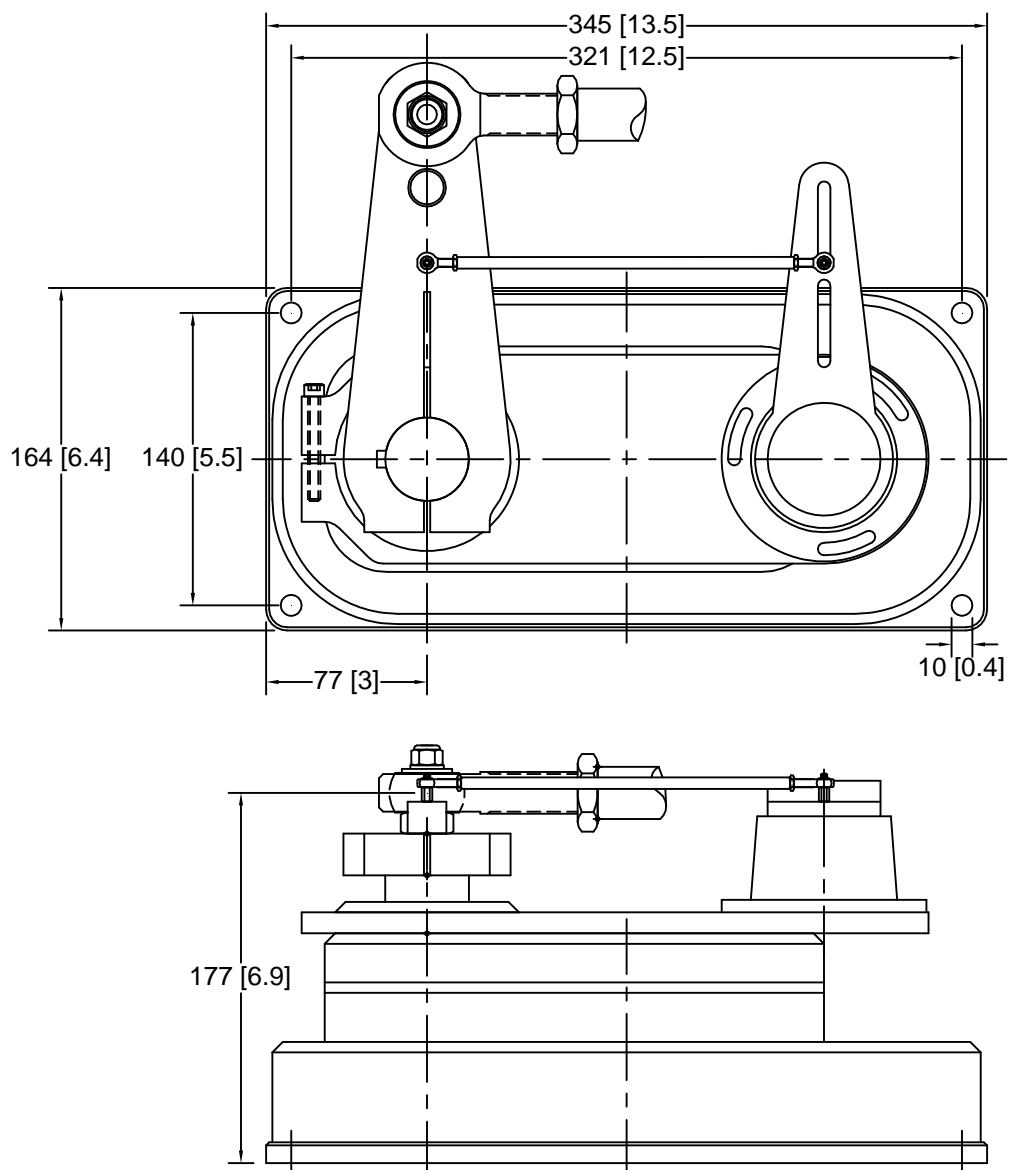

Figure 5-1 DD15 Dimensional drawing

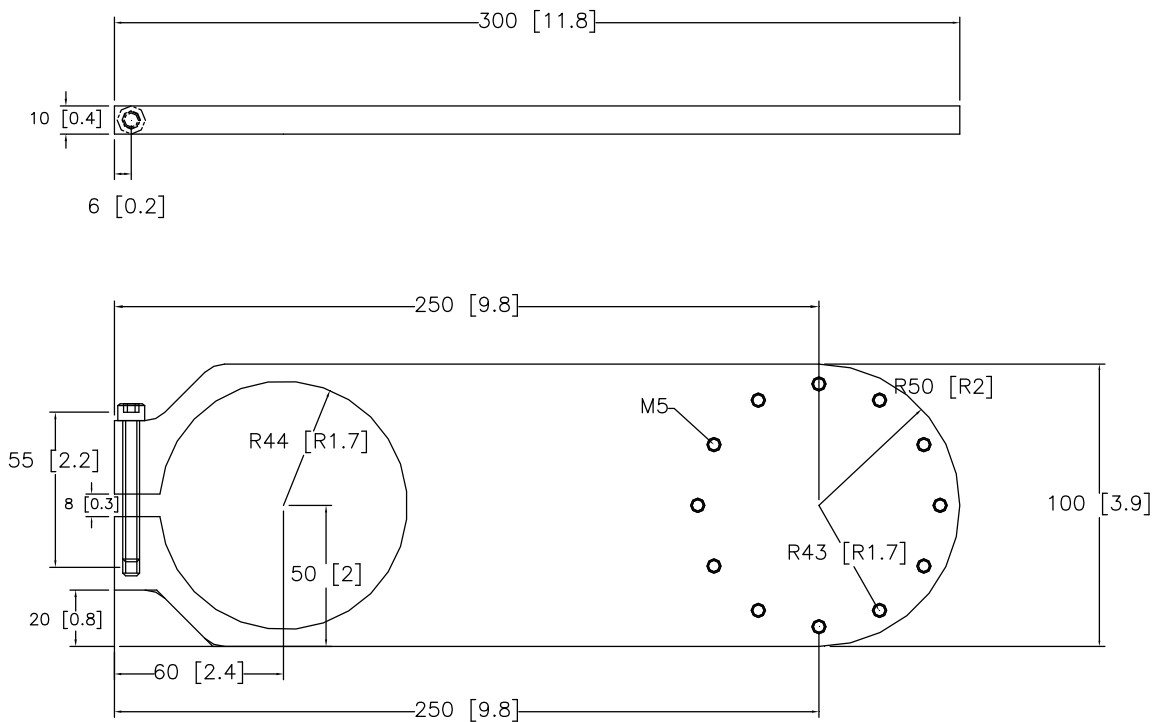

Figure 5-2 Rudder feedback bracket - Dimensions

Draglinks

44172088	Draglink DL3040 (300 [11,8"] - 400 [15,7"] mm)
44172096	Draglink DL2030 (200 [7,9"] - 300 [11,8"] mm)
44172104	Draglink DL4050 (400 [15,7"] - 500 [19,7"] mm)

Spare Parts

20193744	RF300 Rudder Feedback
20193769	Transmission link
	Draglink ball joint

DIRECT DRIVE SPECIFICATION FORM

Version 1.2

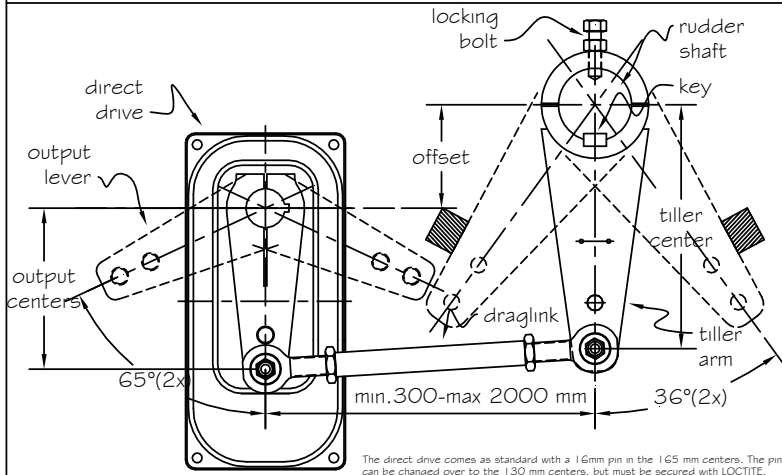

Direct drive type I operating centres in mm valid for 72° (2x36°) rudder travel.

output centers	offset distance	tiller centers
130	106	200
165 (standard)	127	250

specify draglink length (please cross the appropriate box)

200-300mm (DL2030)	
300-400mm (DL3040)	
400-500mm (DL4050)	
500-600mm (DL5060)	

custom length |mm

The direct drive comes as standard with a 16mm pin in the 165 mm centers. The pin can be changed over to the 130 mm centers, but must be secured with LOCTITE.

specification of tiller arm

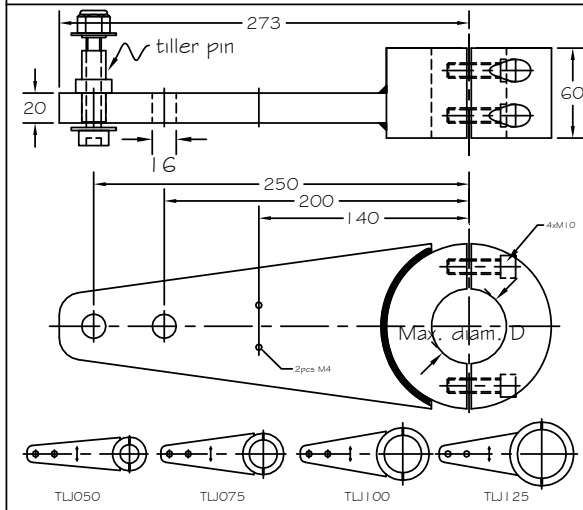

bore diameter = mm

please select the tiller arm by crossing the correct box

bore diam.	tiller arm	cross box
- 50 mm	TLJ050	
51-75mm	TLJ075	
76-100mm	TLJ100	
101-125mm	TLJ125	

to include a tiller pin please cross below box

include TLJPIN 16	
-------------------	--

specification of tiller arm locking mechanism

	if a key is present, specify dimensions		if no key is present, cross below box for locking bolts	
	key width b =			include 2 off M10 locking bolts
	key height h =			
	key angle a =			
	no keyway			

special requirements / comments

DD15 Direct Drive manual EN, Doc.no.20222303, Rev.A



SIMRAD

Master the Elements