



Operation Manual

superwind sw 350

Table of Contents:		Page
1.	General information and references	4
1.1	Labelling	4
1.2	Range of application	4
2.	Safety instructions	5
2.1	Potential sources of danger	5
2.1.1	Mechanical dangers	5
2.1.2	Electrical dangers	5
2.1.3	Dangers when mounting	6
3.	Technical characteristics, required space	7
3.1	Required space	7
3.2	Technical data	7
3.3	Functional description / special features	8
4.	Preparations for assembly	9
4.1	Packing list	9
4.2	Tools	10
4.3	Accessories	10
5.	Electrical components and electrical connection	10
5.1	General information	10
5.2	Wiring diagrams	11
5.2.1	Wiring diagram without charge regulator	11
5.2.2	Wiring diagram with charge regulator CR 30 W	11
5.2.3	Wiring diagram with charge regulator marine CRM	12
5.3	System components	12
5.3.1	Wires	11
5.3.2	Battery	13
5.3.3	Charge regulator	14
5.3.4	Fuses	14
5.3.5	Stop switch	15
5.4	Earthing	15
6.	Wind generator assembly	16
6.1	Precautions	16
6.2	Mast mounting	16
6.2.1	Mounting on a standard mast	16
6.2.2	Mounting on other masts	18
6.2.3	Mounting on a 1 ½ "-tube	19
6.3	Wind vane	20
6.4	Rotor assembly	20
6.4.1	Fastening the rotor blades to the hub	20
6.4.2	Mounting the hub to the generator shaft	22
7.	Commissioning	23
7.1	Check list	23
8.	Operation	24
8.1	Safety instructions	24
8.2	RUN and STOP	25
8.3	Power control	23
8.4	Overspeed protection	25
8.5	Annual power production	26
9.	Inspections, maintenance	27
9.1	Periodic inspections	27
9.1.1	Rotor blades	27
9.1.2	Bolted connections	27

9.1.3	Bearings, seals	27
9.1.4	Carbon brushes	27
9.1.5	Corrosion protection	28
9.1.6	Mast	28
9.1.7	Electrical system	28
9.2	Maintenance	28
10.	Trouble shooting	29
10.1	Wind generator does not start	29
10.2	No power output	29
10.3	Unsufficient power output	30
10.4	Battery is not fully charged	30
10.5	Checking the open circuit voltage	30
11.	Repairs, spare parts	31
11.1	Repairs	31
11.2	Spare parts list	31
12.	Warranty	32

Notices:

This information is believed to be correct and reliable. However, superwind GmbH assumes no responsibility for inaccuracies or omissions. The user of this information and product assumes full responsibility and risk.

All specifications are subject to change without notice.

Thank you for purchasing a **superwind 350**.

The **superwind 350** is a wind generator of highest quality and will reliably generate power for many years. However, reliable operation not only will depend on product quality but also on accurate assembling and proper wiring. Please read this manual carefully before you start the installation. Please also keep in mind our safety instructions and warning notices. Our main concern is with your safety.

1. General information and references

1.1 Labelling

This manual refers to the wind generator **superwind 350**

Manufacturer: superwind GmbH
Bonnstrasse 18
D-50321 Brühl
Germany
Tel.: +49 / 2232 / 577357
Fax.: +49 / 2232 / 577368
e-Mail: power@superwind.com
Internet: www.superwind.com

You will find the label with the serial number and the nominal voltage of your **superwind** at the yaw shaft (see drawing).

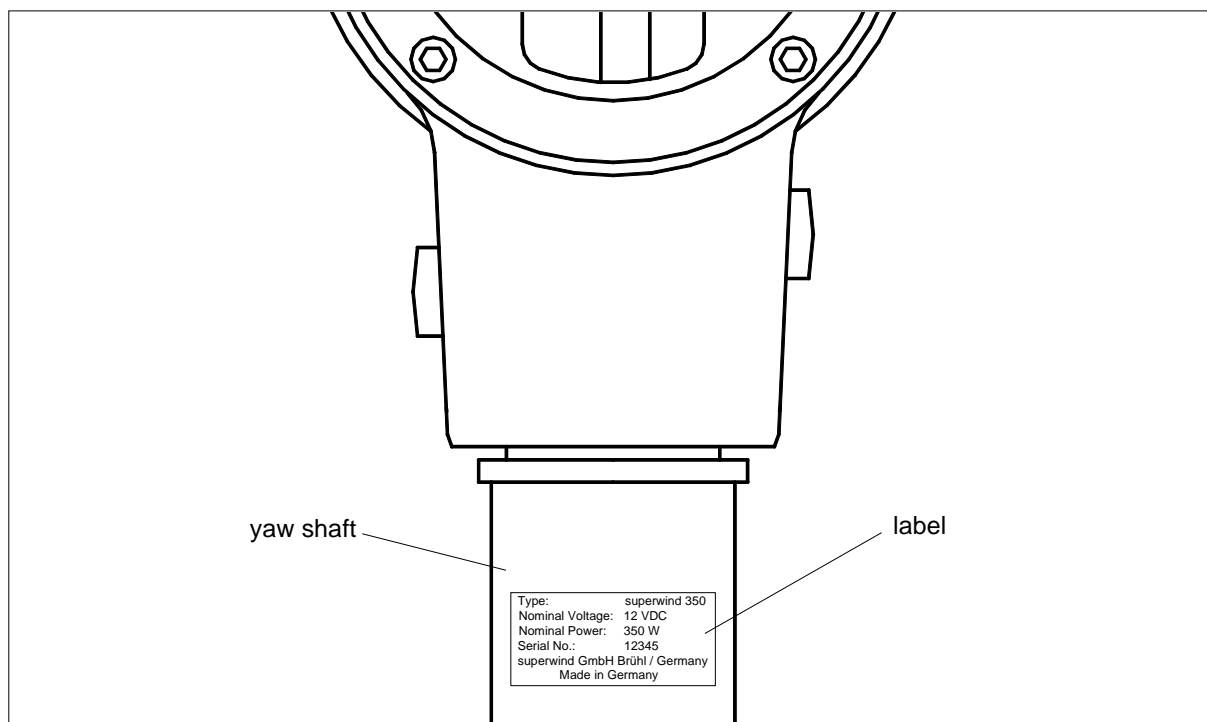

1.2 Range of application

The electric power generated by the **superwind** charges batteries and can directly be used for 12 VDC or 24 VDC-appliances (depending on the system voltage). AC-appliances are supplied via an optional inverter. There is a wide range of high quality 12 VDC or 24 VDC equipment available like energy saving lamps, refrigerators, deep-freezers, water pumps, ventilators, consumer electronics, TV, radio and navigation equipment, etc.

Ideal fields of application for example are sailing yachts, campers, summer cottages, mountain shelters, as well as industrial applications, like navigational aids, traffic management systems, environmental

monitoring stations or transmitters. For rural electrification the **superwind** supplies basic power to families, schools, small health care centres etc.

The combination with solar arrays is without problems. At many places, energy supplies from sun and wind complement each other. That is why the **superwind** is used in wind/solar hybrid systems to optimise the availability of power (at minimised battery capacity).

2. Safety instructions

Please carefully study this manual before starting assembly and installation. The information provided is to ensure your safety during mounting, operation and in case of trouble. If you have any additional questions please contact your dealer, a superwind service partner or the manufacturer.

2.1 Potential sources of danger

Wind turbines in general – including small wind generators like the **superwind** – are electrical machines and thus potential sources of hazards.

2.1.1 Mechanical dangers

The main danger is the spinning rotor. The rotor blades are sharp and can cause very serious injuries even at very low speed.

WARNING: Never touch the running rotor.
Never try to stop the rotor by hand.
Do not mount the rotor at places where any persons can reach the area swept by the rotor.

The rotor blades are made of carbon fibre reinforced plastic. The material is extremely sturdy and enables your **superwind** to cope with heavy storms. However the material can break if any objects, e.g. ropes, battens falling down, branches etc. get into the running rotor. The fragments of the blades are sharp and can be thrown off the rotor at very high speed.

WARNING: Avoid any objects touching the running rotor.

For aerodynamic reasons the rotor blades' trailing edges are very thin and sharp. Unpacking the parts you should be careful, in order to avoid injuries.

2.1.2 Electrical dangers

The generator can produce dangerous open circuit voltages up to 52 VDC (12 V version) and 105 VDC (24 V version) at no-load operation if the electrical connection to the battery or the consumers would be interrupted. This open circuit voltage will be reached at a wind speed of approx. 35 m/s.

The charging current reaches up to 30 Ampere DC (12 V version) or 15 Ampere DC (24 V version). The cabling, all electrical components and connectors must be suitable for 40 Ampere (12 V version) and 20 Ampere (24 V version). For correct dimensioning refer to Section 5.3.

WARNING: Cables with insufficiently dimensioned cross sections can heat up extremely and cause electrical fire.

In order to protect the cabling, fuses must be installed as close to the battery as possible. For details see Section 5.3.

The battery must never be short-circuited. There is serious danger of setting the battery and the cabling on fire. The battery would be destroyed furthermore and acid and gases would be released.

WARNING: You must be extremely cautious never to short-circuit the battery.

Charging lead-acid batteries produces inflammable hydrogen gas. Unsealed lead-acid batteries have vent holes releasing hydrogen which forms detonating gas with the ambient air. A small spark e.g. of an electrical switch can detonate the explosive gas mixture. For explosion prevention therefore always provide sufficient ventilation.

WARNING: Never install the batteries at places with danger of spark formation.
Provide sufficient ventilation at all times.

The dump loads (power resistors) of the optional charge regulators can become very hot. For fire protection they must not be mounted on inflammable surfaces or close to inflammable materials.

WARNING: Never install the power resistors on inflammable surfaces.

2.1.3 Dangers when mounting

These instructions also apply for potential disassembling, checks or other work carried out on your wind generator.

Only use mast and support designs capable safely to withstand the loads of your wind generator. The mast not only has to withstand your wind generator's weight and mass moment of inertia (e.g. on a sailing yacht) but also the considerable thrust caused by high wind speed. Details see Sections 3.2 and 6.1.

Work on the mast or on your wind generator only at a calm and windless day.

Do not step under hanging loads and also prevent other persons from staying underneath e.g. a tilted mast.

Make sure that during all work your batteries are disconnected from the system.

Prevent your wind generator from unintended starting. For this short-circuit the two generator lines (caution: disconnect the battery beforehand!) or tie one of the rotor blades to the mast (if accessible).

WARNING: Never approach the running rotor.

3. Technical characteristics, required space

3.1 Required space

(see drawing)

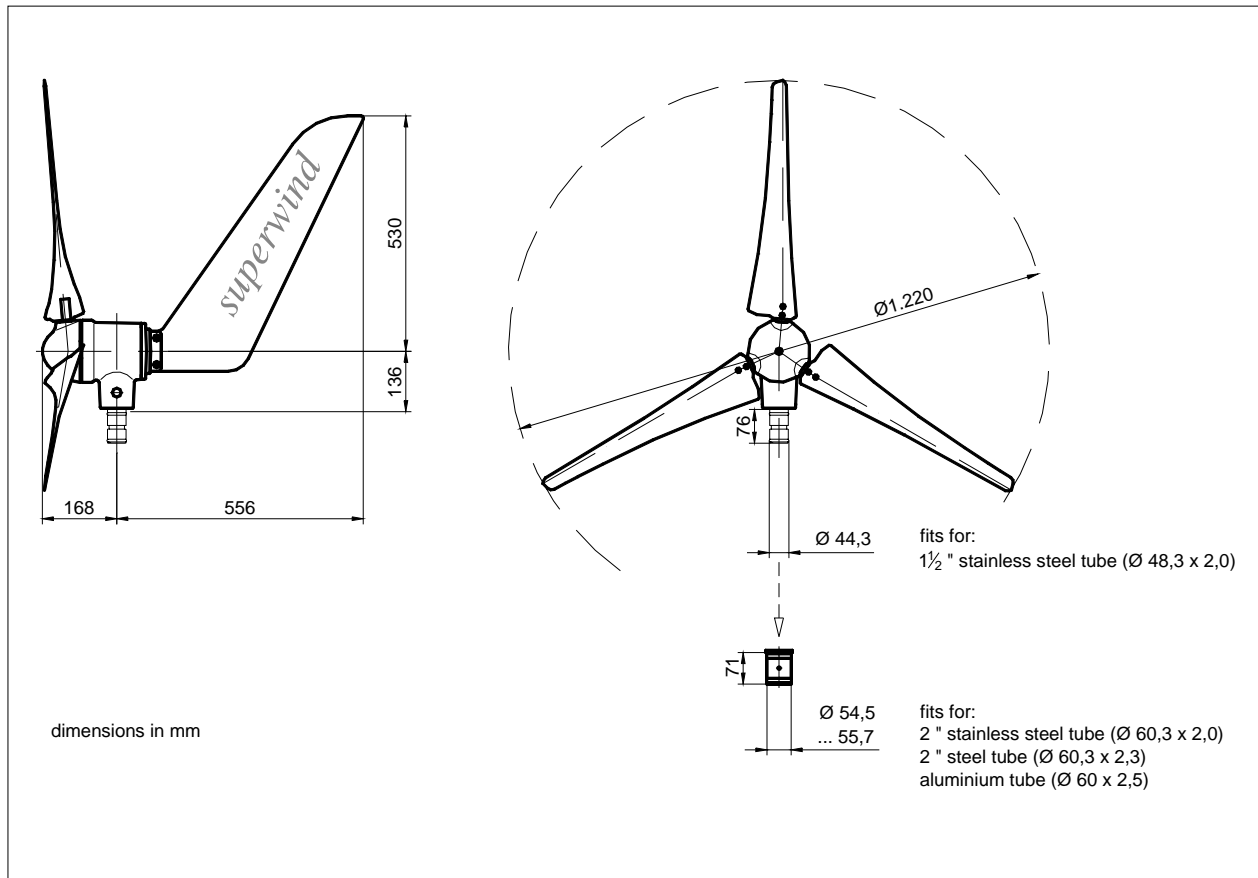

3.2 Technical data

nominal power	350 W
nominal wind speed	12,5 m/s
cut in wind speed	3,5 m/s
cut off wind speed	none
rotor diameter	1,20 m
number of blades	3
blade material	carbon fibre reinforced plastics
rotor speed	500 – 1300 rpm
generator	permanent magnet, 3-phase with rectifier Neodymium magnets
nominal voltage	12 V DC or 24 V DC
speed regulation	rotor blade pitch
power regulation	rotor blade pitch
brake	generator short-circuit
weight	11,5 kg
rotor thrust (operation)	70 N
rotor thrust (extreme wind speed)	220 N

3.3 Functional description / special features

The **superwind**, like all other wind turbines, uses a part of the kinetic energy of the wind and converts it into electricity. The power is approximately proportional to the cube of the wind speed, i.e. doubling the wind speed results to eight times higher power output. With the wind speed varying this means that only relatively little energy can be generated from a moderate breeze. On the other hand a heavy storm contains such a high quantity of energy that the wind generator must be protected against overstressing and damage. Designing the **superwind** special technologies have been developed in order to achieve optimum power output for a wide wind speed range as well as maximum safety at storm conditions.

a) The rotor blades were developed using modern computerized calculation and simulation methods. The airfoil had been wind tunnel tested and was specifically developed for small size rotors.

Relatively broad rotor blades combined with their special pitch angle produce a high start-up torque enabling the rotor to start at only 3.5 m/s wind speed. Annotation: Optimum start-up performance will be reached after a certain running-in period of the bearings and their seals. Using the **superwind** for battery charging please do not mistake the rotor start-up for the start of charging. The wind speed required to start charging depends on the battery's state of charge and might be slightly higher than the rotor start-up wind speed.

b) The basic innovation of **superwind** is its novel aerodynamic rotor control system. Similarly to large wind turbines it adjusts the pitch angle of the rotor blades. The mechanical controller is fully integrated into the hub and works without expensive electrical or hydraulic components. Instead, the controller is actuated by forces arising at operation of the wind turbine itself. The forces are effected by the geometric and kinematic lay-out of the rotor and controller mechanism.

Aerodynamic forces act as control variable to adjust the rotor blades for power regulation above the nominal wind speed. Centrifugal forces are the second control variable for the rotor blade adjustment. By the special arrangement of both force components, the controller limits the rotor speed even at extreme wind velocities automatically, and protects the wind turbine from over speed, even at no-load operation. As a result the controller limits the mechanical loads at high wind speed significantly and guarantees smooth operation under all weather conditions.

4. Preparations for assembly

4.1 Packing list

Please check your delivery for completeness and transport damage.

Packing list:

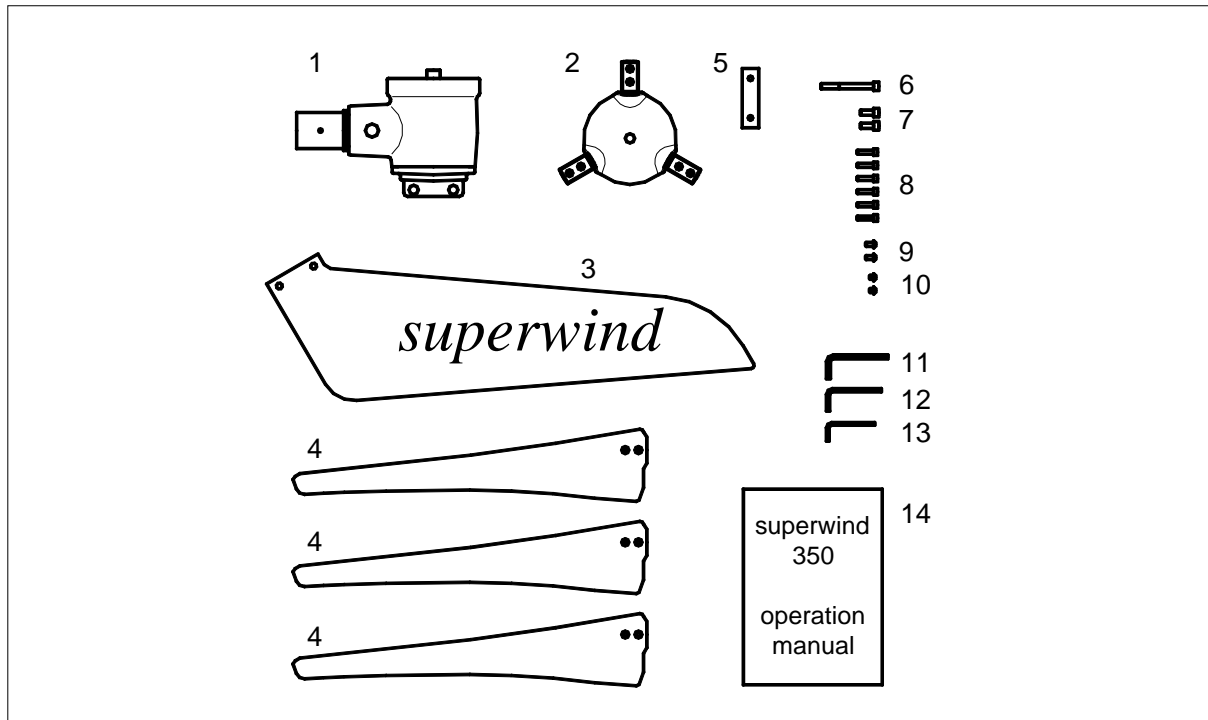

1	pcs	generator		Pos.	1
1	pcs	hub		Pos.	2
1	pcs	wind vane		Pos.	3
3	pcs	rotor blade		Pos.	4
1	pcs	wind vane mounting plate		Pos.	5
1	pcs	socket cap screw	M8 x 80	Pos.	6
2	pcs	socket cap screw	M8 x 20	Pos.	7
6	pcs	socket cap screw	M6 x 25 (TUFLOK)	Pos.	8
2	pcs	hexagon socket button head screw	M6 x 12	Pos.	9
2	pcs	hexagon socket button head screw	M6 x 6	Pos.	10
1	pcs	allen key	6 mm	Pos.	11
1	pcs	allen key	5 mm	Pos.	12
1	pcs	allen key	4 mm	Pos.	13
1	pcs	operation manual		Pos.	14

NOTE: For aerodynamic reasons the rotor blades' trailing edges are very thin and sharp. When unpacking the parts you should be careful, in order to avoid injuries.

4.2 Tools

For installation of your **superwind** a set of allen keys is supplied. It is recommended to prepare some additional tools as follows:

screw drivers
set of spanners
wire strippers
wire crimpers
heat shrink or electrical tape
multimeter

For correct tightening of the screws a torque wrench is recommended.

Tools for the mast installation are not listed here. See respective instructions.

4.3 Accessories

mast-sets:

mast-set for yachts
mast-set for land installation / guyed tubular mast 6 m (other heights on request)
mast-set for land installation / self supporting tubular mast 7,5 m

electrical components:

for land applications:	charge regulator CR 30 W incl. power resistors
for yacht applications:	charge regulator marine CRM incl. power resistors
fuses	40 Ampere, slow-blow
fuse holder	
stop-switch	
ammeter	

5. Electrical components and electrical connection

5.1 General information

Always abide by the acknowledged rules of technology and the rules for accident prevention when working on your **superwind** or the electrical system.

Take care that works on the electrical system like installation, maintenance and repair is carried out by qualified persons only. These persons must also have studied the instructions before given in this manual.

NOTE: After careful planning first the electrical components should be installed at their respective places. The electrical connection should be made in a second step.

NOTE: Make sure that the batteries are disconnected until installation is complete.

5.2 Wiring diagrams

5.2.1 Wiring diagram without charge regulator (stop switch required)

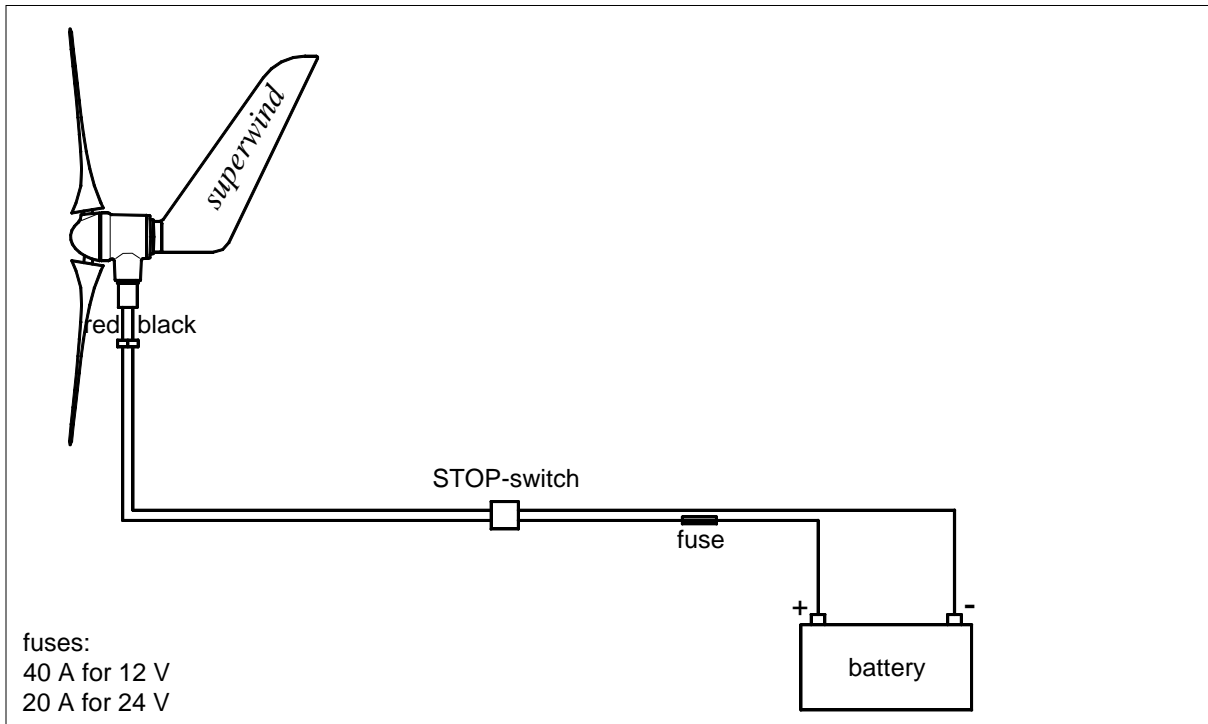

5.2.2 Wiring diagram with charge regulator CR 30 W

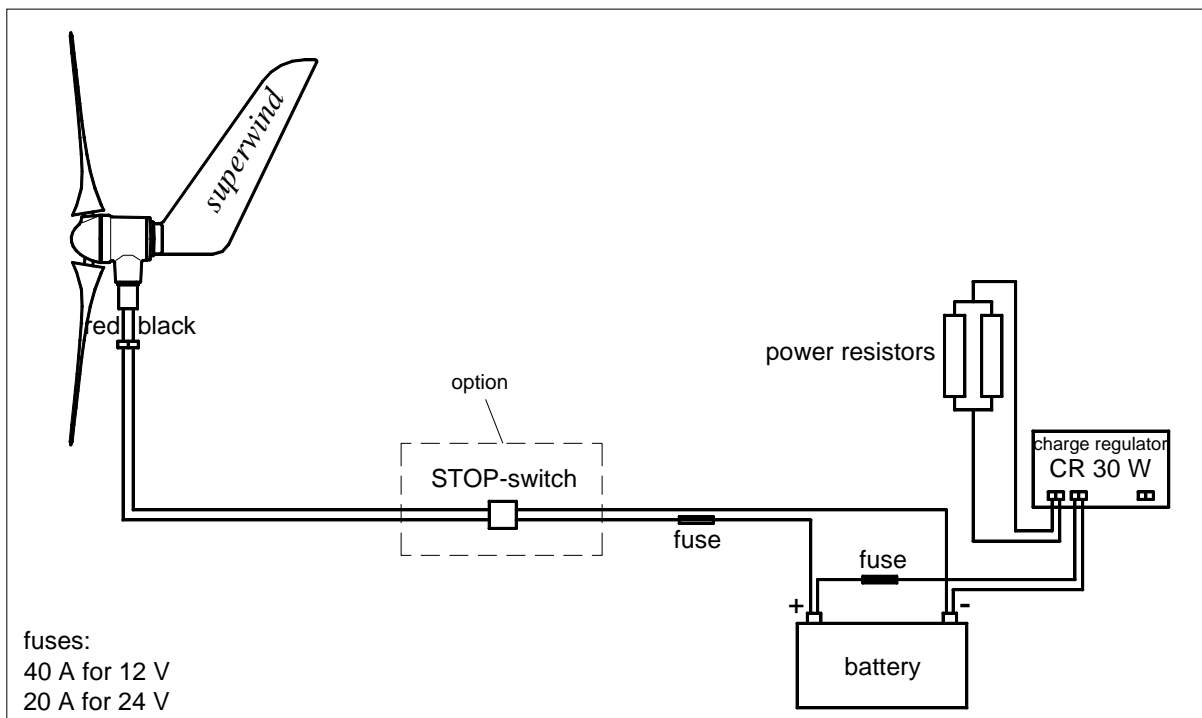

5.2.3 Wiring diagram with charge regulator marine CRM

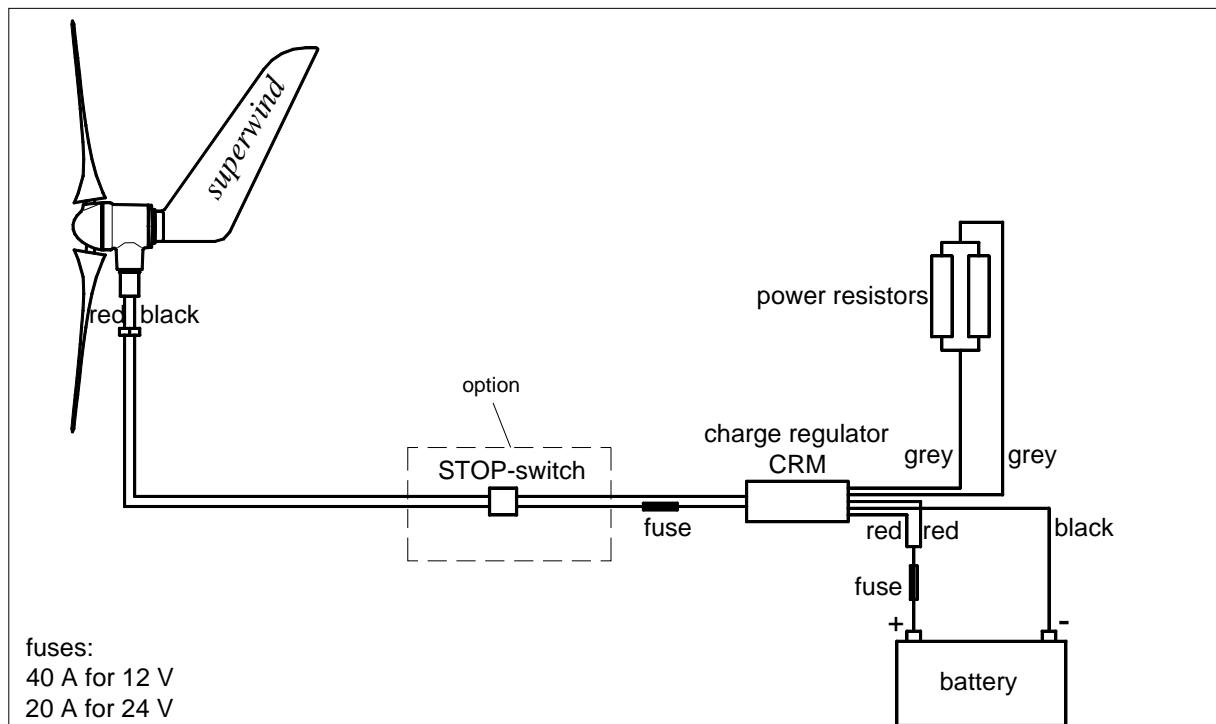

For more wiring options for yachts (several battery banks etc.) refer to the CRM installation manual.

5.3 System components

5.3.1 Wires

The cross sections of the wires to be used depend on their length and the rated voltage of your wind generator. After you decided where to set up the mast measure the distance from the mast head to the battery and then select the minimum cross section required on the basis of the following tables. In order to keep the losses of power in the lines as small as possible, you should not use lines with under-sized cross sections.

For the 12 Volt version applies:

distance from mast head to the battery	Up to 10,6 m	10,7 – 17,6 m	17,7 – 28,2 m	28,3 – 44,1 m	44,2 – 68,1 m	68,1m – 110 m
minimum cross section recommended per cable	6 mm ²	10 mm ²	16 mm ²	25 mm ²	35 mm ²	50 mm ²

For the 24 Volt version applies:

distance from mast head to the battery	up to 10,6 m	10,7 – 17,6 m	17,7 – 28,2 m	28,3 – 42,4 m	42,3 – 70,6 m	70,7 – 112,9 m
minimum cross section recommended per cable	2,5 mm ²	4 mm ²	6 mm ²	10 mm ²	16 mm ²	25 mm ²

WARNING: Cables with insufficiently dimensioned cross sections can heat up extremely and cause electrical fire.

For applications on board a boat or at offshore locations, cables with tinned braids are recommended, in order to prevent corrosion by salty air. If the cable is to be laid into the ground, a special ground cable must be used, and/or it must be led through a tube. In any case an ultraviolet resistant cable should be used, so that it is protected against environmental influences. Same applies to the isolation (heat shrink sleeves, insulating tape) at the junction points. For protection of the cable against chafing through the hole at the bottom of the mast must be properly deburred. If necessary pull a piece of rubber tube over the cables.

For connecting to the terminals the cable ends are to be stripped and suitable wire end ferrules or lugs must be crimped.

Depending on the mast length and the cross section the cable in the mast might be quite heavy. If the cable hanging in the mast weighs more than 5 kg, a strain relief must be attached in the mast cap, so that the internal junction point at the slip rings of your **superwind** will not be damaged.

Always pay attention to the correct polarity of the lines. Connecting to the batteries with interchanged polarity will destroy the electric rectifier of your **superwind**. In general you should mark all line ends by POSITIVE(+) and NEGATIVE (-), in order to prevent errors with the connection.

Marking of the connecting cables at the **superwind**:

POSITIVE (+) :	RED
NEGATIVE (-) :	BLACK

WARNING: The internal electric rectifier of the **superwind** will be destroyed by connecting with interchanged polarity. (loss of warranty!)

5.3.2 Battery

The most common application of the **superwind** is charging batteries. For special applications it is possible to operate the system without charge regulator. This would require however the continuous monitoring of the state of charge of the batteries by the operator and a stop switch for shutting down the **superwind** in case of fully charged batteries. We therefore generally recommend to install a suitable charge regulator. The charge regulator allows operating the **superwind** completely unsupervised and automatically; the batteries are charged optimally and protected against overcharging and benefit from a substantially longer life span.

When selecting the batteries pay attention to the correct rated voltage (12 V or 24 V). The rated voltage of your **superwind** is specified on the type label.

Lead acid batteries are most commonly used. The charge regulators recommended in the accessory list are suitable for all types of batteries. We recommend batteries for stationary use. Solar batteries are well suitable, because they have a long life span. They are usually maintenance-free and better survive occasional deep discharge. Car batteries are less suitable because they wear out very fast by cyclic operation, which probably will be the normal case for your system.

Another important criterion for battery selection is the capacity, expressed in ampere-hours (Ah). This value represents the quantity of storable energy. The required capacity depends on your individual situation (wind location, consumption structure, combination with other generators like PV etc.). Your battery dealer surely will assist you selecting the suitable battery.

When selecting the place of installation for the battery refer to the instructions of the battery manufacturer.

Charging lead-acid batteries produces inflammable hydrogen gas. Unsealed lead-acid batteries have vent holes releasing hydrogen, which forms detonating gas with the ambient air. A small spark e.g. of an electrical switch can detonate the explosive gas mixture. For explosion prevention therefore always provide sufficient ventilation.

WARNING: Never install the batteries at places with danger of spark formation. Provide sufficient ventilation at any time.

Batteries store a large quantity of energy, which suddenly is discharged in the case of a short-circuit. This can destroy the battery (emission of battery acid and gas), can set the battery and the cabling on fire and therefore must be avoided in all cases. For this reason the battery terminals may be only connected after all work on the electric system has been completed.

WARNING: Never short-circuit the battery.

NOTE: The battery terminals may be connected only after all work on the electric system has been completed.

For protection against too high currents and or short-circuit, **fuses** must be installed in the positive (+) wires to the battery. See the connection diagram in Section 5.2 and the references in Section 5.3.5. Since blowing a fuse or releasing an automatic circuit breaker can cause an electrical spark, these may not be installed in the same area as the battery.

Act with extreme caution while handling corrosive battery acid, refilling of distilled water or performing other maintenance on the batteries. Follow the instructions of the battery manufacturer and wear protective clothing and suitable eye protection.

WARNING: Act with extreme caution while handling corrosive battery acid.
Wear protective clothing and suitable eye protection.

5.3.3 Charge regulator

We recommend to install the charge regulators CR30W or CRM (for yachts). These regulators are adapted optimally to the **superwind** 350 and ensure effective charging of the batteries. The charge regulator CR 30 W adapts to the system voltage of 12 V or 24 V automatically. The charge regulator CRM is particularly suitable for yachts and is available in versions for 12 V and 24 V.

Before installing the charge regulator please read the respective operating instructions. Also follow the instructions concerning the point of installation. The charge regulator should be placed close to the battery as it detects their ambient temperature for optimum performance.

The resistance of the lines between the charge regulator and the battery affects the charging voltage detected by the regulator. Therefore the lines must be as short as possible (max. 1 meter). The charge regulators are not protected against interchanged polarity of the lines and would be damaged.

WARNING: Do not interchange the polarity of the cables.

If you want to use another charge regulator than described here, make sure that it is a shunt-regulator. Series controllers as often used in photovoltaic systems are unsuitable, since they interrupt the electric circuit for voltage regulation and thus the wind generator would run in no-load operation. Furthermore the charge regulator must be laid out for currents of at least 30 A (12 V version) or 15 A (24 V version).

5.3.4 Fuses

To protect the battery against short-circuit fuses must be installed in the positive line between the wind generator and the battery and in the positive line between the battery and charge regulator. The fuses are of 40 ampere slow-blow type (12 V-system) or 20 ampere slow-blow type (24 V-system) or appropriate automatic circuit breakers.

The fuses must be placed as close to the battery as possible, however not with it in the same compartment. Unsealed lead-acid batteries have vent holes releasing hydrogen which forms detonating gas with the ambient air. A spark when blowing the fuse (or releasing an automatic circuit breaker) can detonate the explosive gas mixture.

5.3.5 Stop switch

A stop switch (option) is not obligatory if a charge regulator has been installed. The stop switch is used to shut down the wind generator if it is not to be operated or to prevent starting of the rotor when working on it.

When using the superwind on a boat or a sailing yacht the stop switch is strongly recommended to shut the wind turbine down in heavy weather at sea. Spray and waves, parts detached from the rig or from the sails etc. could touch the rotor. Furthermore in such situations the restricted mobility on board increases the risk of accidentally touching the running rotor.

If you run the system without charge regulator, a stop switch is obligatory. In this case the state of charge must be continuously supervised by the operator and terminated when the battery is fully charged. The stop switch disconnects the *superwind* from the battery and simultaneously shuts down the rotor. The stop switch must be installed in the line between the wind generator and the battery (see connection diagram in Section 5.2) as close to the wind generator as possible. In this line between wind generator and stop switch fuses or circuit breakers must not be installed.

The stop switch has two positions:

- a) RUN
The positive line from the generator is connected to the battery.
The negative line from the generator is connected to the battery.
- b) STOP
The positive line and the negative line from the wind generator are short-circuited (generator short circuit brakes the rotor).
The positive and the negative lines from the battery are both open and disconnected from the wind generator.

For further information concerning the connection of the stop switch refer to the respective installation manual.

WARNING: Do not use a stop switch from an other manufacturer. The switch must be of such type of construction that in no case the battery is short-circuited when switching.

5.4 Earthing

In order to protect your system against damage by lightning or over voltage, you should earth it adequately. The design of the earthing system depends on the local conditions, like place of installation, type of soil, groundwater table or a earthing bus already existing. If you are in doubt, consult an electrician close-by. He knows the local conditions and regulations.

When installing the *superwind* on a yacht we recommend to connect its mast or support to the ship's earthing system.

6. Wind generator assembly

6.1 Precautions

Before you start installing your wind generator please keep in mind the potential dangers and act with caution.

Only use a mast and support construction capable safely to withstand the loads of your wind generator. The mast not only has to withstand the weight of the wind generator and its mass moment of inertia (e.g. on a sailing yacht) but also a considerable thrust caused by high wind speed. The maximum thrust by wind at operation will be approx. 70 N. In an extreme gust (wind speed of 49 m/s) the thrust can rise up to 220 N.

Only work on the mast or on your wind generator on a calm and windless day.

Do not step under hanging loads and also prevent other persons from standing underneath e.g. a tilted mast.

Make sure that during all work your batteries are disconnected from the system.

Prevent your wind generator from unintended starting. For connect the two generator cables together (caution: disconnect the battery before!) or tie one of the rotor blades to the mast (if accessible).

WARNING: Do not approach the running rotor.
Never try to stop the rotor by hand.
Do not install the wind generator at places where the rotor area could be approached by persons.

6.2 Mast mounting

Before your superwind is finally installed on the mast or support, the electric cables must be led through the mast tube and be connected to the generator with correct polarity (also see Section 5.3).

NOTE: The following applies to any kind of mast or support:
Before assembling the wind generator make sure that from the mast top to a point 650 mm below there are no out-standing fittings or ropes which could obstruct the rotor. This is important because the rotor controller pitches the blades at high wind velocities and by this their distance from the mast will be reduced.

6.2.1 Mounting on a standard mast

The yaw shaft of your *superwind* fits for various sizes of mast tubes:

<u>description</u>	<u>outer-Ø</u>	<u>thickness</u>	<u>inner-Ø</u>	<u>material</u>
2 "-tube	60,3 mm	2,3 mm	55,7 mm	steel, welded
2 "-tube	60,3 mm	2,0 mm	56,3 mm	stainless steel, welded
aluminium tube	60,0 mm	2,5 mm	55,0 mm	aluminium, seamless
1 ½ "-tube (*)	48,3 mm	2,0 mm	44,3 mm	steel, welded

(*) see Section 6.2.3

With welded tubes pay attention that the welding seam does not obstruct the insertion of the yaw shaft. If necessary, an out-standing seam must be smoothed with a round file or the like.

Preparations at the mast head:

- Deburr the end of the tube carefully (inside and outside)
- File off the welding seam if necessary.
- Drill the two holes $\varnothing 7$ mm .

Insert the yaw shaft of your superwind until stop and align the drilled holes of the mast with the tap holes of the yaw shaft's plastic bushing. Screw down the two hexagon socket button head screws for axial fixation.

Drawing:

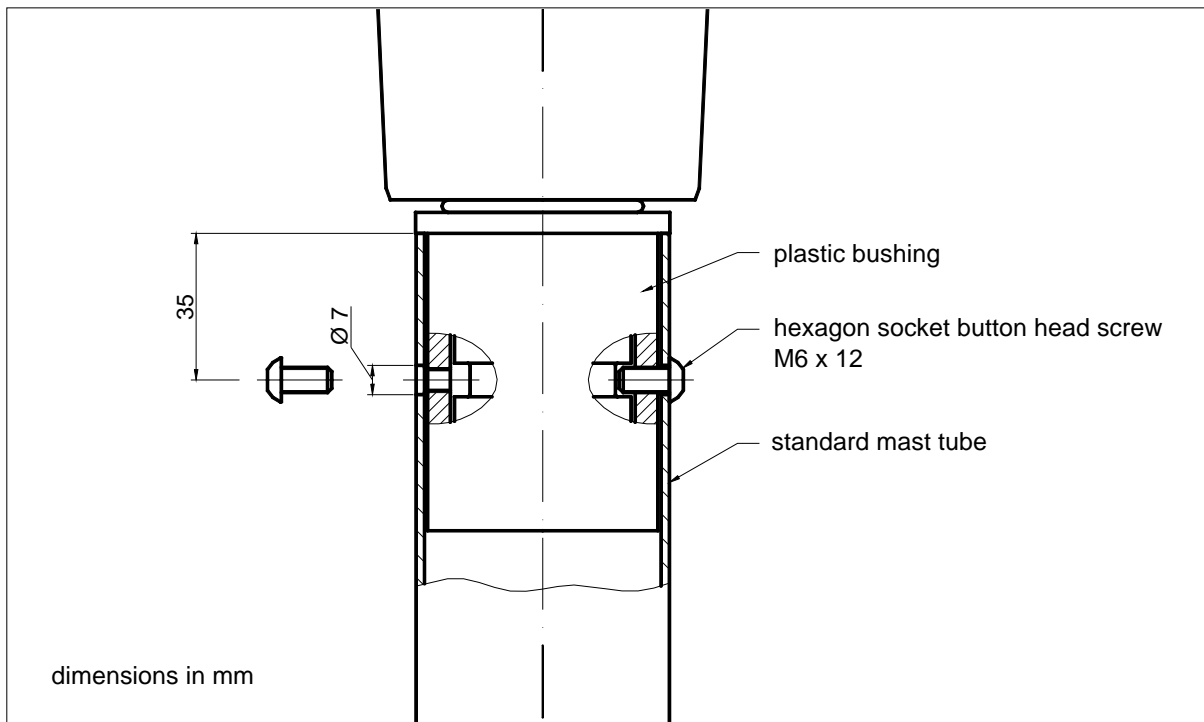

6.2.2 Mounting on other masts

As the *superwind's* yaw shaft is inserted into the mast tube the inner diameter must be appropriate. The outer diameter may be not greater than 70 mm, so that there is sufficient space between the mast and rotor blades. There also must be no out-standing fittings or ropes which could obstruct the rotor.

Drawing:

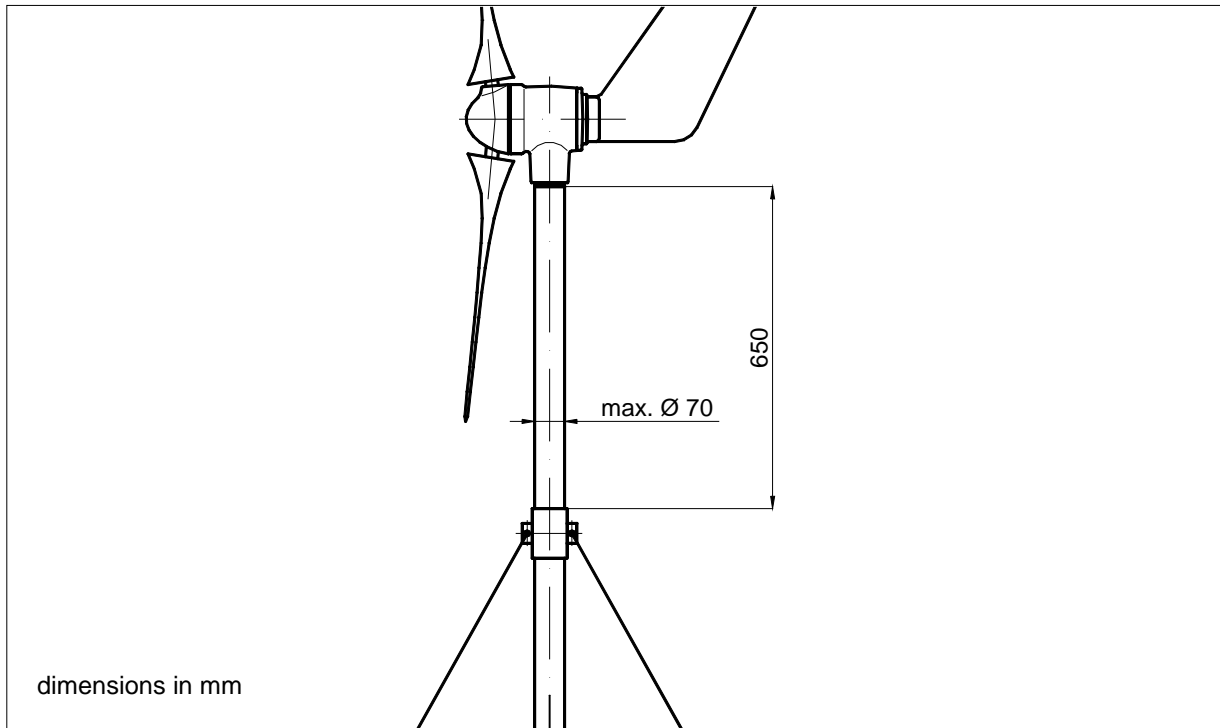

Preparations at the mast head:

- Deburr the end of the tube carefully (inside and outside)
- File off the welding seam if necessary.
- Drill the two holes $\varnothing 7$ mm .

Depending on the size of your tube the two hexagon socket button head screws M6 x 12 provided for axial fixation may be too short. In this case appropriate screws must be used. The screws however should not be too long and must not shut the inner aluminium part of the yaw shaft. Otherwise the vibration and impact sound absorber would be without effect.

6.2.3 Mounting on a 1 1/2 " tube

(*) Occasionally some sailing yachts have an existing 1 1/2 " mast which has been used for an other type of wind generator before. This tube also fits for the **superwind** if the inner diameter is not smaller than 44.0 mm.

Preparations at the mast head:

Deburr the end of the tube carefully (inside and outside)

File off the welding seam if necessary.

Drill the two holes \varnothing 5 mm and tap M 6. The distance from the mast head to the holes must be exactly 40 mm.

Drawing:

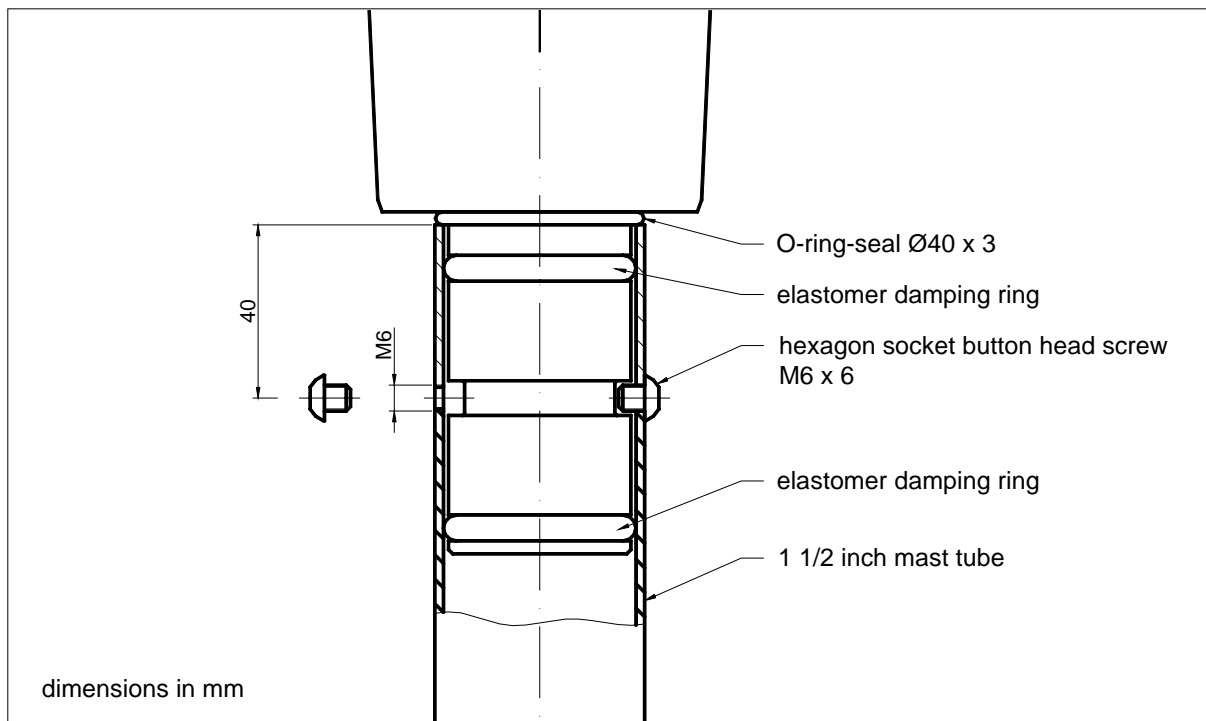

Remove the yaw shaft's plastic bushing and leave the two elastomer damping rings and the O-ring seal \varnothing 40 x 3 at their position. After lubricating the damping rings and the inside of the tube with Vaseline insert the yaw shaft into the tube. Screw in the two hexagon socket button head screws M6 x 6 provided for axial fixation. The screws should only protrude into the yaw shaft's slot but not touching it. That way you will benefit from your **superwind's** vibration and impact sound absorber, too.

6.3 Wind vane

The wind vane is fastened to the rear cover of the generator. Insert the wind vane and the mounting sheet into the groove. From the back-view the mounting sheet must be on the right side. Now insert the two socket cap screws M8 x 20 and screw them down firmly.

Drawing:

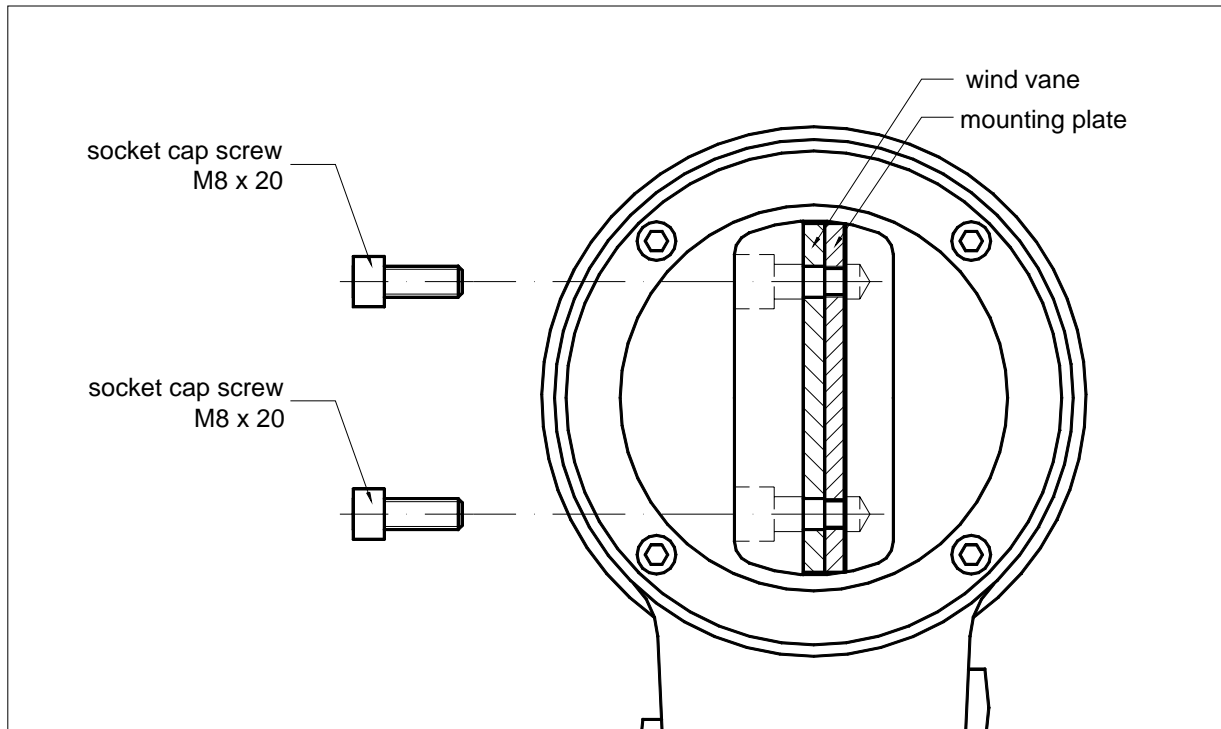

6.4 Rotor assembly

There are two methods to assemble the rotor of your **superwind**:

- a) first the hub is fixed to the generator shaft and the rotor blades are fixed to the hub later.
- b) the rotor blades are fixed to the hub first and after that the completed rotor is fixed to the generator.

We recommend method b), since it is in most cases easier, first to pre-mount the rotor completely at a convenient place and afterwards to take it to the wind generator.

6.4.1 Fastening the rotor blades to the hub

NOTE: For aerodynamic reasons the rotor blades' trailing edges are very thin and sharp. When unpacking the parts you should be careful, in order to avoid injuries.

The rotor blades were arranged at the factory, to sets with three rotor blades of same mass. Therefore the rotor blades can be fixed to the hub in arbitrary order. It is not permissible however to mount rotor blades from different sets to the hub since then the rotor could be out of balance. This also applies in the case of a damaged single rotor blade. It is obligatory always to exchange the entire rotor blade set.

The accurate position of the rotor blades at the hub is ensured by a special fitting. The flattenings of the axles sticking out of the hub have two cylindrical counter bores each. The rotor blades have rectangular recesses with two cylindrical tenons, which fit into the cylindrical counter bores of the axle with light force.

Drawing:

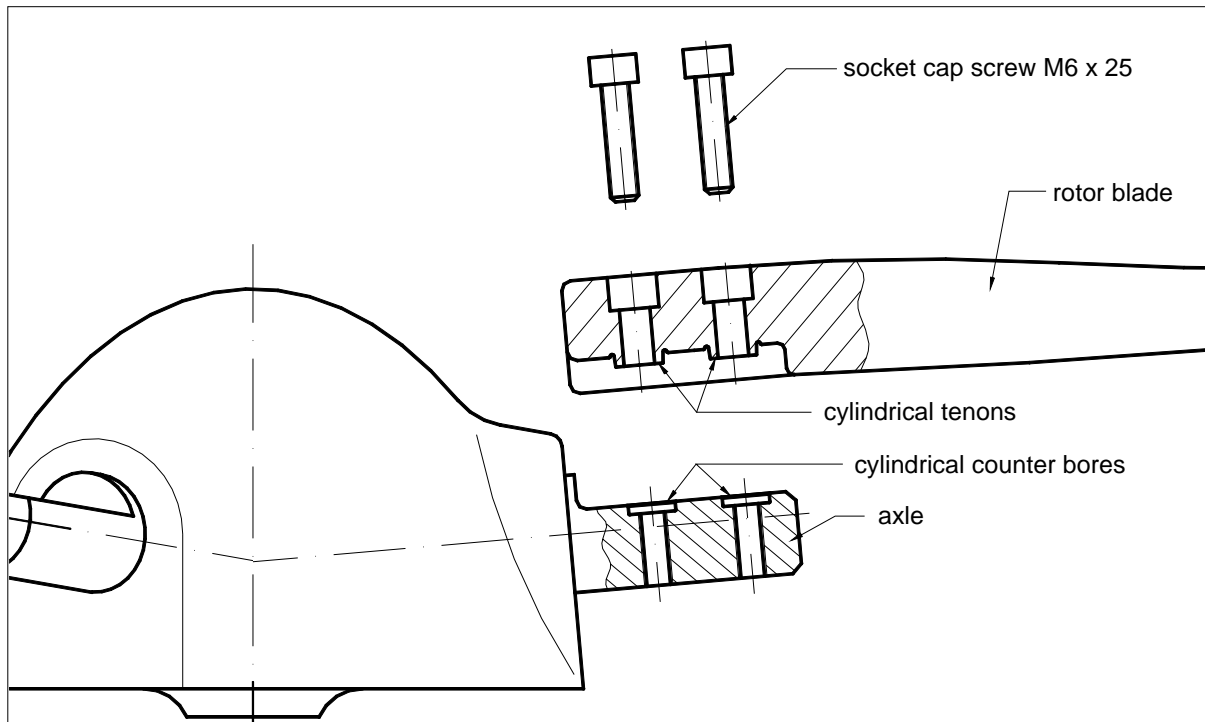

The rotor blades are fixed by two socket cap screws M6 x 25, which are TUFLOK-coated to prevent loosening at operation. When screwing in you will sense a slight drag torque due to the coating.

Place the hub with the flat side on a soft surface. The flattenings of the three axles thus point upward transversely. Now attach the first rotor blade with its rectangular recess to one of the axles that way that its both cylindrical tenons fit into the associated counter bores of the axle with light pressure. Do not use too much force, because the fits could be damaged. If you are sure, that both tenons are inserted correctly to the counter bores, screw in the two socket cap screws M6 x 25. If mounting the blade the first time we recommend to screw in the screws alternately (a half turn each) until the tenons are completely pressed into the counter bores.

When the rotor blade is attached to the axle correctly do not just tighten the screws, since excessive tightening for one time could damage the blade material. For the correct initial tension, a torque of 4.5 Nm is required. If you don't have a suitable torque wrench the following method is recommended:

Check if the contact surfaces of the blade and the axle fit properly by screwing the screws somewhat in and out. When the screw feels tight, it indicates that the screw head presses on the rotor blade. Screw down from now on exactly another quarter turn in order to adjust the correct initial tension.

Mount the two other rotor blades the same way.

NOTE: Make sure, that the blades's tenons are correctly inserted into the axles' counter bores
Do not use force.
Do not overturn the screws.

6.4.2 Mounting the hub to the generator shaft

NOTE: Prevent your wind generator from unintended starting. For this connect the two generator cables together (caution: disconnect the batteries beforehand!) or tie one of the rotor blades to the mast (if accessible).

When the rotor has been assembled take it to the generator. Hold the rotor at the hub only, since the sharp edges of the rotor blades could cause injuries. This way you will also avoid unnecessary loads on the blades when carrying.

Slide the rotor on the generator shaft carefully. In doing so take care not to push the generator shaft into the housing of the generator unit. Insert the socket cap screw M8 x 80 through the hub and tighten it until you can not feel any axial play. Now tighten the screw at 35 Nm.

Drawing:

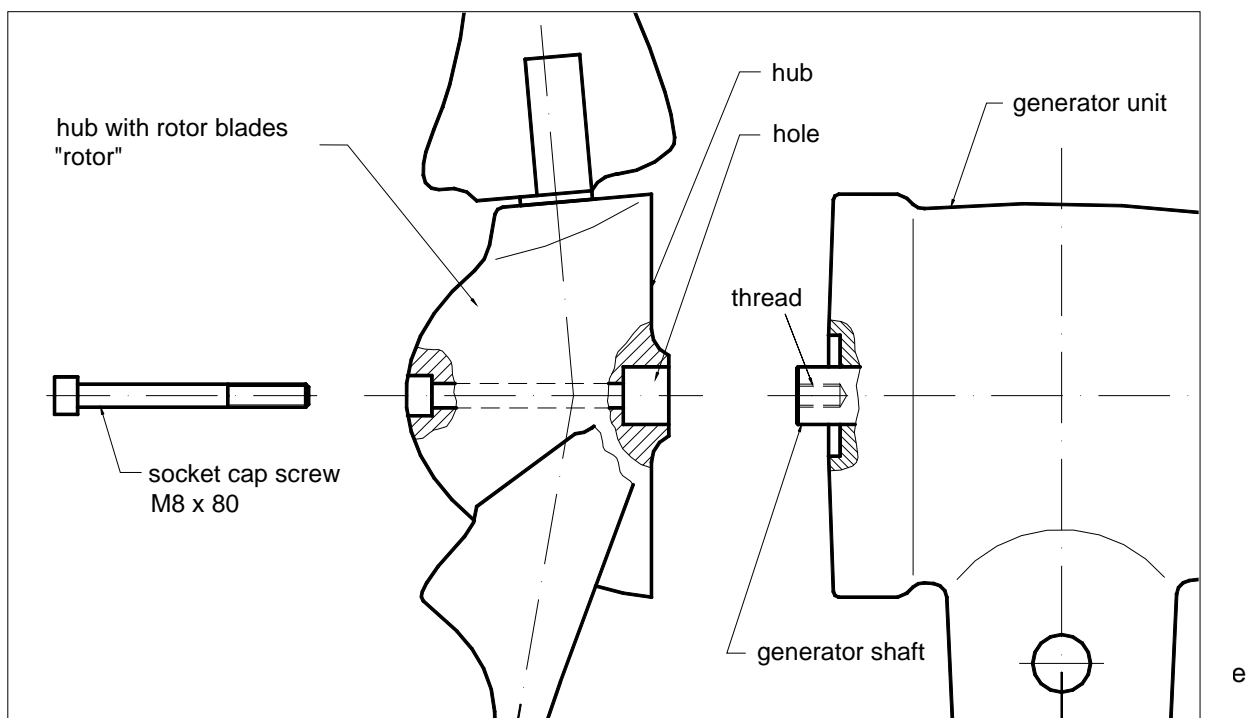

7. Commissioning

Before initial operation check the correct installation of you new **superwind** with the check list.

7.1 Check List

done		also see
<input checked="" type="checkbox"/>		Section:
<u>Mast:</u>		
assembled and erected in accordance to the respective manuals. Bolts, joints, anchors and braces checked. Mast vertically adjusted.		
<u>Earthing / lightning protection:</u>		
mast / support grounded		5.4
earth wire connected to the grounding bus		5.4
		5.4
<u>Electrical system:</u>		
batteries correctly installed and acid level o.k.		5.3.2
charge regulator correctly fixed and connected		5.3.3
power resistors correctly fixed and connected. Installation point provides adequate heat dissipation		5.3.3
fuse holders fixed and connected		5.3.4
fuses 40 A (12 V system) or 20 A (24 V system) prepared		
stop switch (option) correctly installed and connected		5.3.5
Ammeter (option) correctly installed and connected		
Cabling in accordance to wiring diagram and correctly connected		5.2
Correct polarity of all cables and connections		5.3.1
<u>Wind Generator:</u>		
Cables connected with correct polarity		5.2
strain relief for cables provided (if necessary)		5.3.1
Yaw shaft correctly inserted and fixed by screws		6.2
Wind vane correctly fastened with mounting sheet , screws tightened		6.3
Rotor blades correctly fastened		6.4.1
Rotor blade screws tightened at 4.5 Nm		6.4.1
Hub mounted on the generator shaft and tightened at 35 Nm		6.4.2

After the installation work has been carried out correctly and everything has been checked, now disconnect the generator lines from each other and connect them with correct polarity to the battery. Insert the fuses and if you have a stop switch put it into RUN position. Now your new **superwind** is ready for operation.

CONGRATULATIONS !

8. Operation

8.1 Safety instructions

Do not run your **superwind** unless you have definitely made sure that no persons can touch the running rotor.

Do not run your superwind without electrical load. (e.g. no load connected at all or battery fully charged without charge regulator connected).

8.2 RUN and STOP

Your **superwind** is designed for unattended automatic operation in all weather conditions. Nevertheless there might be situations you would like to stop it. For that purpose use the stop switch recommended. For wiring see Section 5.3.5.

In RUN position the wind generator supplies power to the battery and to the consumers connected. Switching into STOP position, the wind generator will be disconnected from the battery and the generator leads will be short-circuited simultaneously. The generator short circuit shuts down the rotor. At high wind speed the rotor will not slow down completely but will continue running at very low revs.

WARNING: Never try to stop the running rotor by hand. Even slowed down by the stop switch the slowly running rotor can cause serious injuries.

If there is no stop switch wired, the only way to slow down your **superwind** is to disconnect the generator from the battery, and to connect the generator leads to each other. Be careful and definitely avoid short-circuiting the battery.

8.3 Power control

As described in Section 3.3 the *superwind* is equipped with a unique aerodynamic rotor control system. The special safety feature is represented by the fact that the power absorbed from the flowing air is directly regulated at the point of impact, namely the rotor blades. Thus the entire mechanical structure and the generator is protected against overload. The power control is working perfectly provided that the generator will be loaded corresponding to its nominal power. Adequate loads are electrical consumers such as the batteries to be charged, or the charge regulator.

Function:

The rotor blades are pivoted and can adjust their pitch angle to leeward. Below the nominal wind speed the controller keeps the pitch angle in normal position. Above the nominal wind speed the rotor control system adjusts the blade pitch exactly to the specific angle that keeps the power output constant.

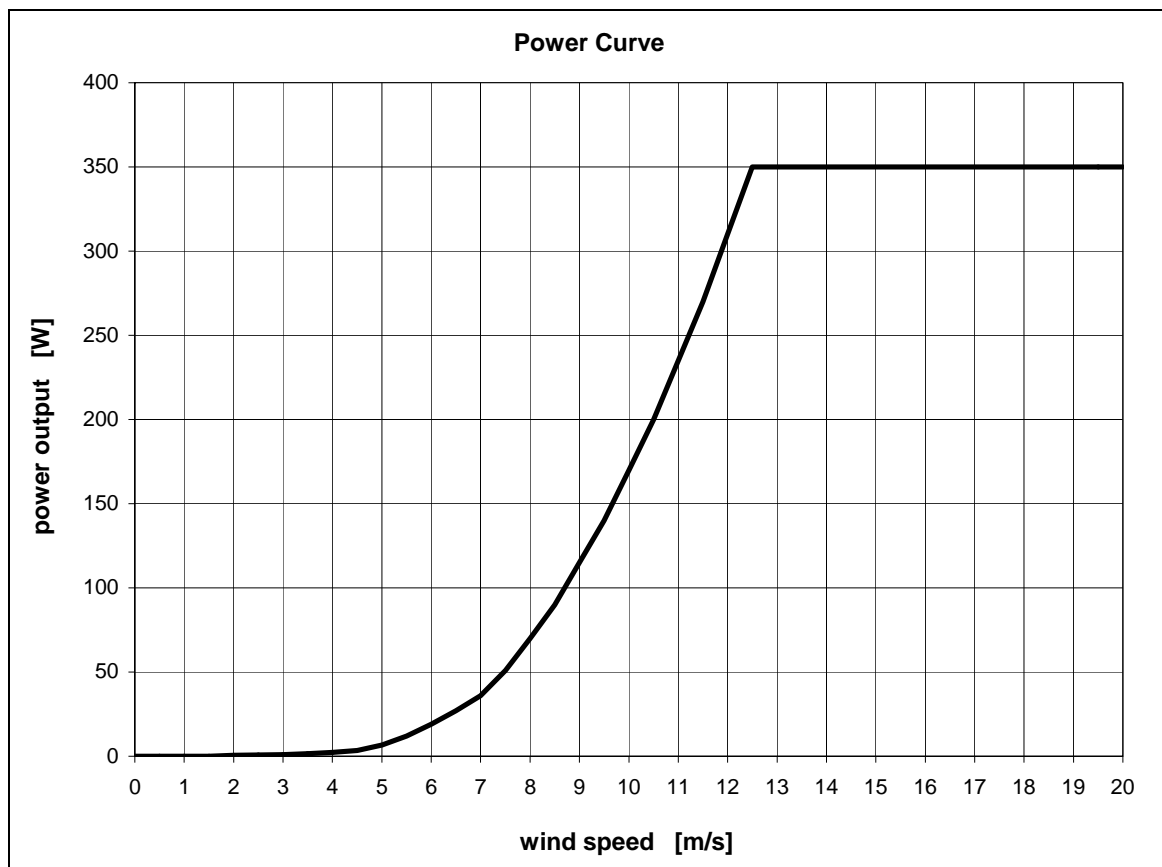

8.4 Overspeed Protection

Furthermore the *superwind* is the only small wind generator equipped with a rotor control system which includes an overspeed controller. The overspeed controller works at all wind speeds even without electrical loads. Although it is not a normal operation mode, load throw-off could occur under certain conditions e.g. with blown fuses, malfunction of the charge regulator or electrical failures caused by overvoltage or lightning strike.

Function:

The rotor control system responds to both, aerodynamical and centrifugal forces affecting the rotor blades. Due to the special geometric rotor blade layout and the matched rotor controller mechanism the rotor at no-load operation first accelerates to an increased idle-speed. The idle-speed will be kept on a nearly constant level, only slightly speeding up if the wind speed would increase further on. That way at no-load operation the rotor control system provides extra safety against high centrifugal forces and guarantees a very high level of safety.

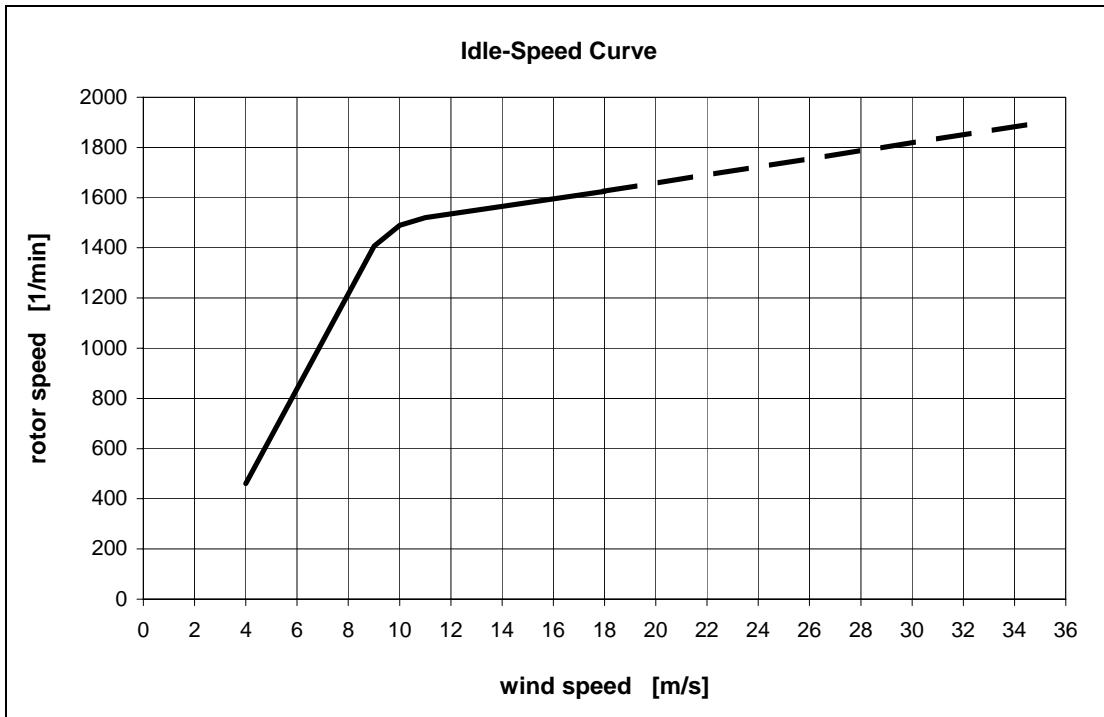

8.5 Annual power production

The electrical power is the product of voltage and current. It depends on the generator speed and the load connected (i.e. the electric resistance of the consumers).

The producible power is determined by the wind conditions at your site. The annual power production is the amount of power your wind generator can produce at a specific annual mean wind speed. The diagram shows the annual power production versus Rayleigh distributed annual mean wind speeds.

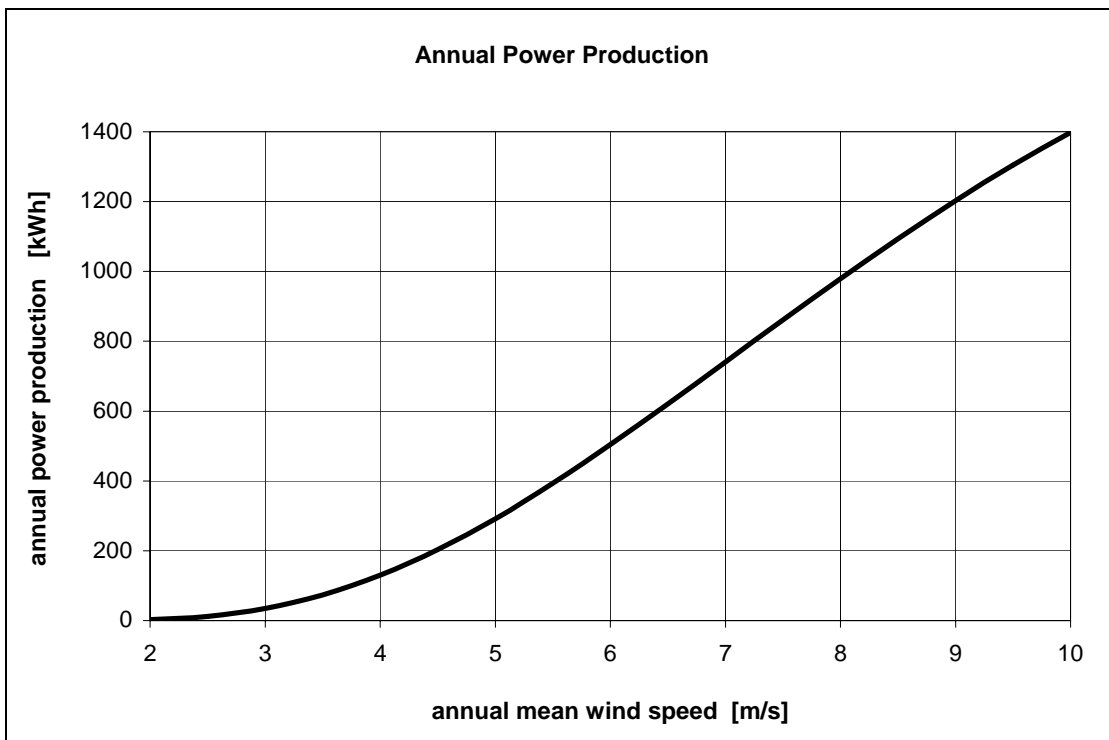

9. Inspections, maintenance

9.1 Periodic inspections

Your **superwind** has been designed to run for years without maintenance, but simple periodic inspections are required for reliability and safety.

Before performing any inspection disconnect the **superwind** from the batteries and shut down the rotor as described in Section 8.2.

WARNING: Do not approach the running rotor.
Never try to stop the rotor by hand.

Only work on the mast or on your wind generator on a calm and windless day.

Do not step under hanging loads and also prevent other persons from standing underneath e.g. a tilted mast.

The inspections described below should be performed every 12 month.

9.1.1 Rotor blades

Check the rotor blades for damage (e.g. cracks, broken edges, unusual discolouring etc.). If you see any damage, your **superwind** must be put out of operation and the complete rotor blade set has to be replaced. It is not permissible to mount rotor blades from different sets to the hub, since then the rotor could be out of balance.

Dirt on the blades spoils the airfoil performance and reduces the power output. If necessary clean the blades with a sponge using only soap and water. Do not use abrasive or chemical cleaners.

9.1.2 Bolted connections

Check all accessible bolted connections making sure they are tightened at the correct torque. This applies especially to the bolts of the rotor blades, the hub and the wind vane. Also check the bolts securing the yaw shaft. Refer to Section 6.

9.1.3 Bearings, Seals

The generator bearings and the yaw shaft bearings are sealed and lifetime lubricated. Check the bearings for smooth running, clearance and leak tightness. Defective bearings must be replaced at an authorized service station.

9.1.4 Carbon Brushes

Check the carbon brushes for wear and unusual loss of contact material. Unscrew the two black cylindrical screw caps (see drawing below) and pull out the carbon brushes. Worn or damaged carbon brushes must be exchanged. Before you screw on the caps again, also check the O-ring seals.

Drawing:

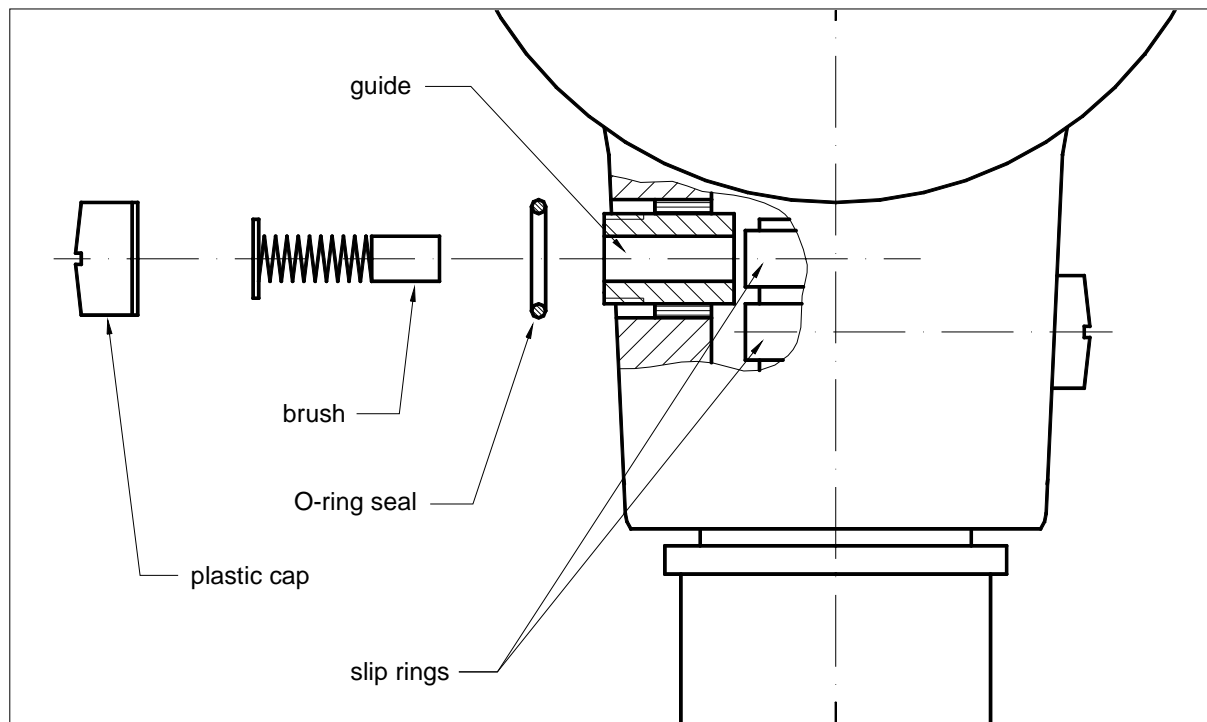

9.1.5 Corrosion protection

All housings, as well as the wind vane are made of a sea water-proof aluminum alloy and are additionally protected by a powder coating. This coating however only can adhere optimally to the housing surface, if it is not damaged. Therefore check for damage and touch up the coating with suitable lacquer .

All steel parts e.g. ball bearings, shafts, axles and bolts are made of stainless steel and need no special corrosion protection.

9.1.6 Mast

Check your mast or support. Refer to the respective instruction.

9.1.7 Electrical system

Inspections of the electrical system shall only be performed by qualified persons. Before performing any inspection make sure that all lines are safe and that the wind generator cannot start unintentionally.

Check all electrical connections making sure that they are tight and free from corrosion. Particularly pay regard to the battery terminals, since these especially are prone to corrosion. If corroded clean and cover them with battery terminal grease.

Check the battery fluid level and add distilled water when necessary. Refer to the instructions of the battery manufacturer.

9.2 Maintenance

There is no special maintenance required. The periodic inspection however shall be performed every 12 month.

10. Trouble shooting

If problems occur after installation of your new **superwind** you probably can solve most of them following the trouble shooting list.

At all times be aware of electrical and mechanical hazards:

WARNING: Do not approach the running rotor.
Never try to stop the rotor by hand.

WARNING: Be careful when doing work on the electrical system, since most of the lines are live.

WARNING: Never short-circuit the batteries.

Useful tools for trouble shooting are a multimeter (voltage, current, electrical resistance) and an anemometer (wind speed).

10.1 Wind generator does not start

possible source of errors	test	solution
not enough wind	measure wind speed	wait for more wind. Annotation: start-up wind speed 3,5 m/s (during running-in period slightly higher)
stop switch in STOP position		switch to RUN
wrong connection of the stop switch	check stop switch and connection	connect correctly
debris between generator housing and hub	find the debris	remove the hub from the generator shaft and eliminate debris
generator shaft is stiff	turn generator shaft by hand. (for this test the generator must not be short-circuited)	repair by authorized service station
yaw bearing is stiff, wind generator does not follow the wind direction	move by hand	repair by authorized service station

10.2 No power output

possible source of errors	test	solution
not enough wind	measure wind speed	wait for more wind Annotation: Charging possibly will start only with 4,5 to 5,5 m/s. (depending on the battery's state of charge)
current linkage is interrupted	check the cabling	replace defective line or devices
fuse is blown	check the fuse	replace the fuse
carbon brushes are without contact	check the carbon brushes and the springs	replace the carbon brushes
build-in rectifier is defective	no increased torque sensible when generator cables have been short-circuited.	repair by authorized service station

10.3 Uninsufficient power output

possible source of errors	test	solution
bad electrical connection	measure the electric resistance of the cabling and devices	replace defective lines or devices, clean connectors and terminals
cable resistance too high	check the cable cross sections and cable lengths	use cables with higher cross sections

10.4 Battery is not fully charged

possible source of errors	test	solution
battery is too old or defective	check fluid level	fill up with distilled water, replace defective battery
fuse is blown	check the fuse(s)	replace the fuse
charge regulator is not connected correctly	check connection referring to the wiring diagram	connect the charge regulator correctly
charge regulator defective	for trouble shooting see respective manual	repair by authorized service station

10.5 Checking the open circuit voltage

A simple test, in order to detect an internal defect of the generator, is measuring the open circuit voltage. Disconnect the cables from the generator and connect a voltmeter to the positive and negative line. To avoid injuries dismantle the rotor blades beforehand. Now turn the hub by hand. Count the revolutions within a certain period (e.g. 30 revs within 10 seconds = 180 rpm). Watch the voltage. The voltage and the speed should correspond to the following diagram:

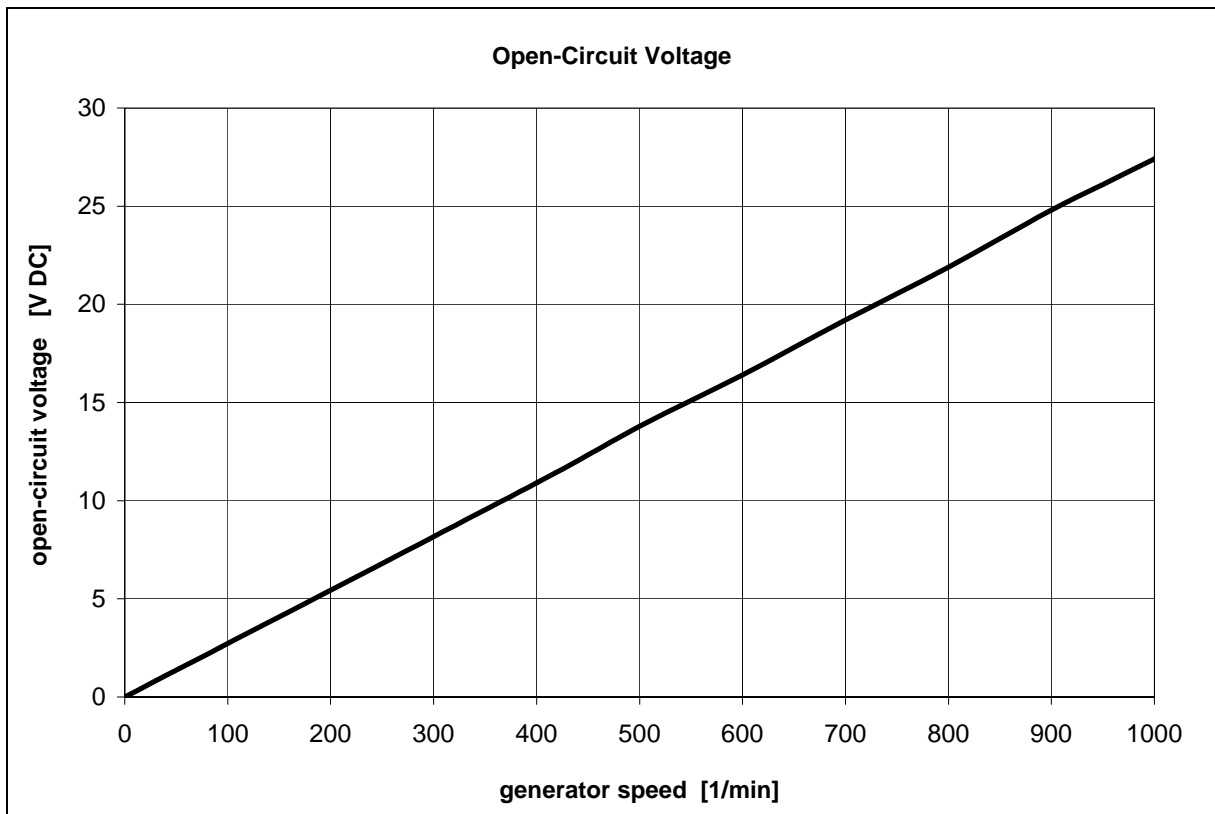

11. Repairs, spare parts

11.1 Repairs

If your *superwind* should be defective you may replace all parts accessible from the outside by yourself (e.g. rotor blades, carbon brushes, damping rings). In case of any other defects please consult your dealer, an authorized service partner or the manufacturer.

WARNING: Do not open the hub housing. The hub is a safety relevant component. For repair special know-how and special tools are required. To ensure safe operation, repairs of the hub may only be performed by authorized service partners or by the manufacturer.

11.2 Spare parts list

- set of rotor blades
- socket cap screw M6 x 25 TUFLOK
- carbon brush
- carbon brush screw cap
- rectifier (incl. capacitors)
- generator bearing front
- generator bearing rear
- hexagon socket button head screw M6 x 6
- hexagon socket button head screw M6 x 12
- socket cap screw M8 x 80
- damping ring 40 x 3

12. Warranty

superwind GmbH warrants this product to be in good working order during the warranty period. In the event that the product is found to be defective within the warranty period repair service will be provided free of charge by superwind GmbH or an authorised service partner.

Free repair service may be obtained only against presentation of the warranty card together with the original invoice issued to the customer by the retailer. The warranty card must state the purchaser's name, the retailer's name and address, the serial number and the date of purchase of the product. superwind GmbH reserves the right to refuse warranty service if this information is not complete or has been removed or changed after the original purchase of the product by the purchaser from the retailer.

Warranty period

The warranty is valid for three years from the date of purchase by the purchaser, as evidenced by the above mentioned documents.

To obtain warranty service

Warranty service is available at superwind GmbH and superwind authorized service partners. Any costs of secure transportation of the product to and from superwind GmbH / superwind authorized service partners will be borne by the customer.

Limitations

superwind GmbH does not warrant the following:

- Periodic check-ups, maintenance and repair or replacement of parts due to normal wear and tear.
- Defects caused by modifications carried out without superwind's approval.
- Defects caused by improper use, handling or operation, in particular defects caused by improper installation and installation on inadequate masts or support structures.
To obtain warranty service the purchaser has to provide evidence that the product has been installed on adequate masts or support structures.
- Accidents or disasters or any cause beyond the control of superwind GmbH, including but not limited to lightning, flooding, fire etc.
- Costs for disassembly and reassembly of the product to enable shipment for warranty reasons.

Others

superwind GmbH reserves the right to decide whether the product or parts of it shall be repaired or replaced instead. In case neither repair nor replacement could be performed by superwind GmbH the purchaser solely will be entitled to cancel the purchase.

This warranty does not affect the purchaser's statutory rights under applicable national legislation in force, nor the purchaser's right against the retailer arising from the sales / purchase contract. In the absence of applicable national legislation this warranty will be the purchaser's sole and exclusive remedy, and superwind GmbH shall not be liable for any incidental or consequential damages for breach of any expressed or implied warranty of this product.

Besides apply the

GENERAL CONDITIONS FOR THE SUPPLY OF PRODUCTS AND SERVICES OF THE ELECTRICAL AND ELECTRONICS INDUSTRY

superwind

superwind GmbH
Bonnstrasse 18
D-50321 Brühl / Germany

Tel. + 49-2232-577357

Fax + 49-2232-577368

e-mail: power@superwind.com

web-site: www.superwind.com