

Vetus[®]

Installatie instructies
Installation instructions
Installationsvorschriften
Instructions d'installation
Instrucciones de instalación
Istruzioni per l'installazione

| | |
|-------------------|----|
| NEDERLANDS | 2 |
| ENGLISH | 4 |
| DEUTSCH | 6 |
| FRANÇAIS | 8 |
| ESPAÑOL | 10 |
| ITALIANO | 12 |

Flexibele schroefaskoppeling

Flexible propeller shaft coupling

Flexible Schraubenwellenkupplung

Accouplement flexible d'arbre porte-hélice

Acoplamiento flexible del árbol porta-hélice

Giunto di accoppiamento flessibile dell'albero dell'elica

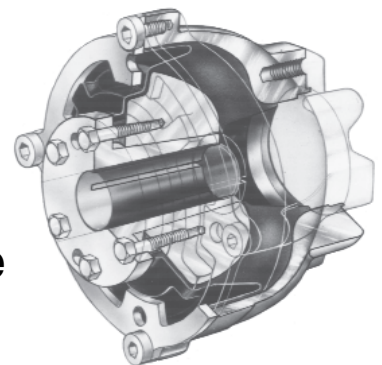

Uniflex

Opstelling

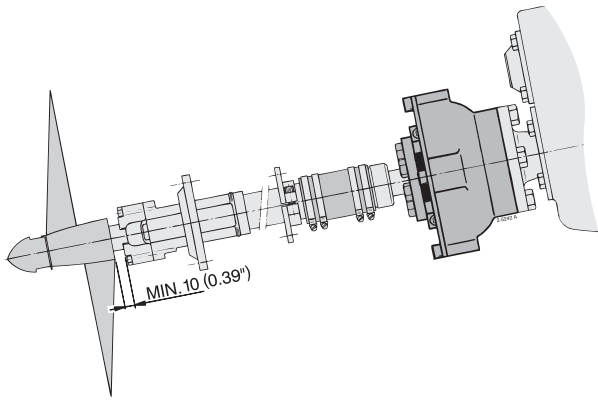

In verband met de axiale beweging van de schroefas moet er tussen het buitenlager en de naaf van de schepsschroef een minimale vrije ruimte zijn. ◀

Stuwkracht

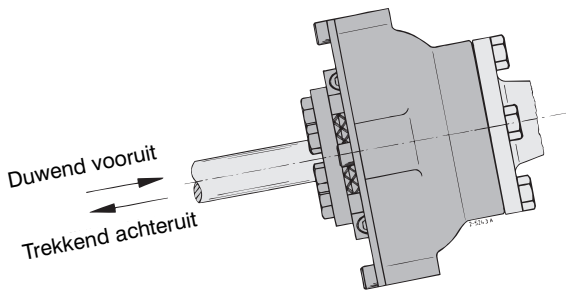

N.B. Bij vooruit varen moet het rubberdeel worden ingedrukt. ◀

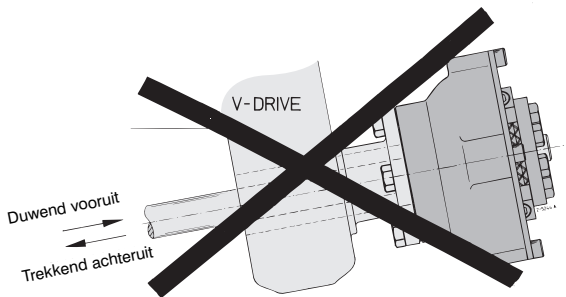

Toepassing van de Uniflex in combinatie met een V-drive keer-koppeling is niet toegestaan! ◀

Afwijkende (grotere) schroefas diameter

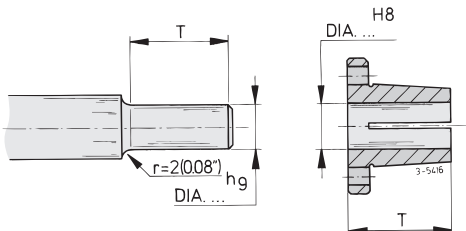

Verklein de schroefas diameter over de lengte van de klembus (afmeting 'T') naar afmeting 'd' van de koppeling, zie 'Hoofdafmetingen'. Radius 'r' minimaal 2 mm. ◀

Uitlijnfout

De maximaal toelaatbare uitlijnfout van de schroefas is 2°. ◀

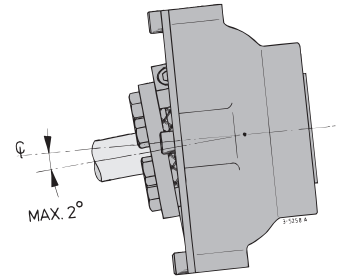

Montage algemeen

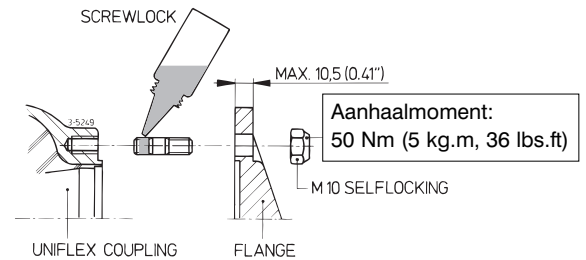
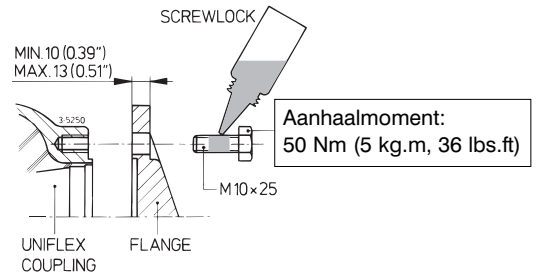

Om een betrouwbaar functionerende koppeling te verkrijgen dienen alle bouten en moeren met de opgegeven momenten te worden aangebracht. Gebruik hiervoor een momentsleutel; het 'op gevoel' aantrekken leidt niet tot bevredigende resultaten. ◀

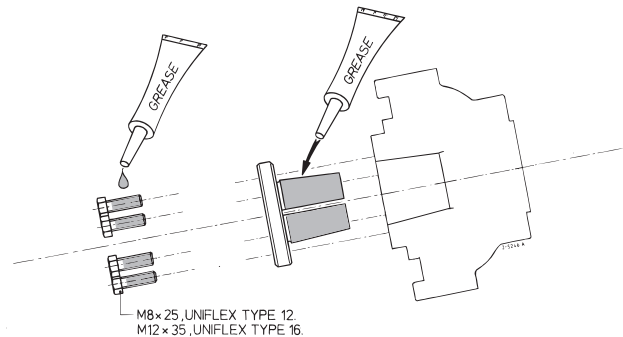
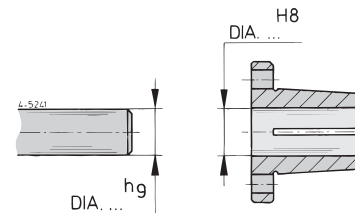

Vet de buitenzijde van de klemconus en de bouten in. ◀

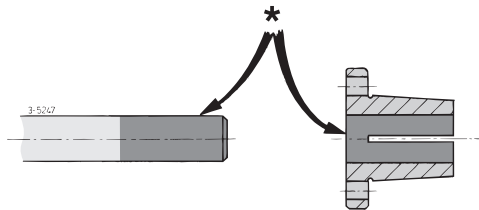

Om slip tussen de klemnaaf en de schroefas te voorkomen dienen deze vrij van vet en vuil (*) te zijn. ◀

Zorg er voor dat de rubberdelen niet worden aangetast door oplosmiddelen. ◀

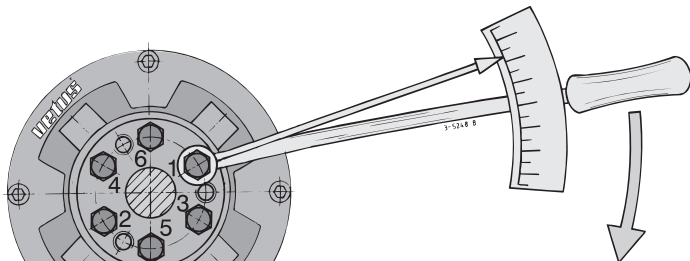
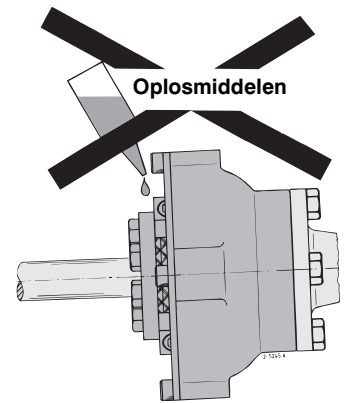

Aanhaalmoment:
Uniflex 12, M8x25: 25 Nm (2,5 kg.m, 18 lbs.ft)
Uniflex 16, M12x35: 90 Nm (9,0 kg.m, 52 lbs.ft)

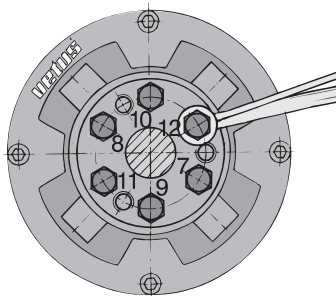

De nummers geven de volgorde aan waarin de bouten moeten worden aangetrokken. Haal, indien noodzakelijk, alle bouten nogmaals aan. ◀

Demontage

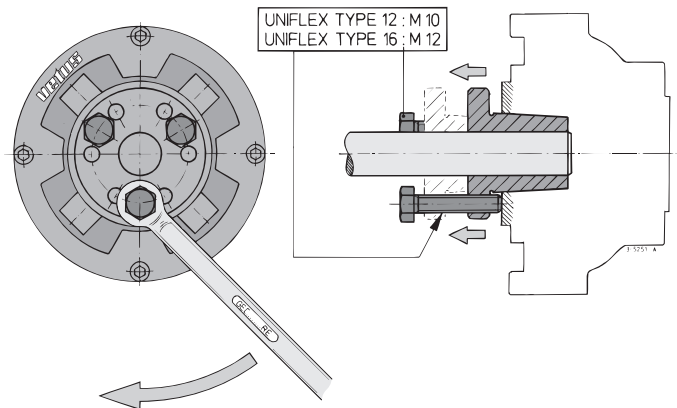

Technische gegevens

| Uniflex | : | 12 | 16 |
|--------------------------------|-----------------|--|---|
| Gewicht | : | 2,8 kg | 6,9 kg |
| Max. koppel volg. DIN6270B | : | 200 N.m | 400 N.m |
| Max. koppel volg. DIN6270A | : | 175 N.m | 350 N.m |
| Max. vermogen volg. DIN6270B * | : | 2,1 kW/100 min ⁻¹ | 4,2 kW/100 min ⁻¹ |
| Max. vermogen volg. DIN6270A * | : | 1,8 kW/100 min ⁻¹ | 3,6 kW/100 min ⁻¹ |
| Massatraagheidsmoment | J | 399 · 10 ⁻⁵ kg.m ² | 1723 · 10 ⁻⁵ kg.m ² |
| | GD ² | 0,016 kgf.m ² | 0,069 kgf.m ² |
| Dyn. torsiestijfheid | : | 900 N.m/rad | 1900 N.m/rad |
| Axiale trekstijfheid | : | 1,7 kN/mm | 1,9 kN/mm |
| Axiale drukstijfheid | : | 2,8 kN/mm | 5,3 kN/mm |
| Max. toerental bij | 2° ** | 1500 min ⁻¹ | 1500 min ⁻¹ |
| | 0° | 4500 min ⁻¹ | 3500 min ⁻¹ |

* Max. vermogen $M_{max} = M_{max} \cdot 2 \cdot \pi \cdot n$ (M_{max} is het max. koppel en n het toerental)

** Maximale hoekverplaatsing voor beide types Uniflex is 2°.

Mounting

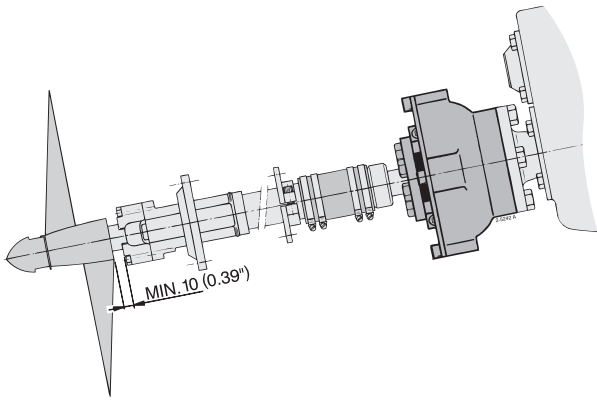

In connection with the axial movement of the propeller shaft a minimum free space between outer bearing and propeller hub is required. ◀

Propeller-thrust

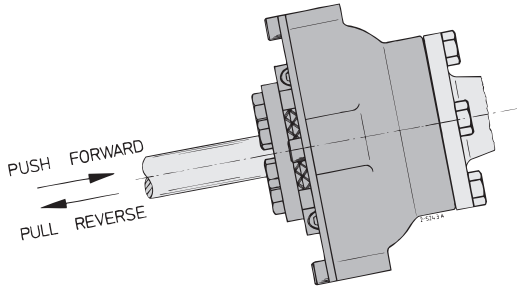

N.B. When sailing in forward direction the rubber part must be compressed. ◀

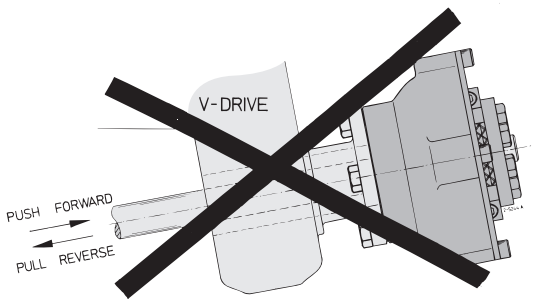

Using the Uniflex in combination with a V-drive type gearbox is not allowed! ◀

Over-size (larger) propeller shaft diameter

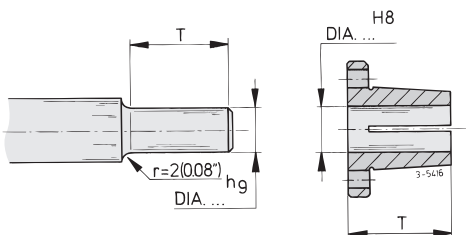

Reduce the propeller shaft diameter for the taper length (dimension 'A') to the given dimension 'd' of the coupling, see 'Overall dimensions'. Radius 'r' minimal 2 mm (0.08"). ◀

Misalignment

The maximum allowable misalignment of the propeller shaft is 2°. ◀

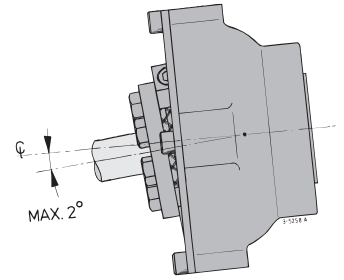

General assembly

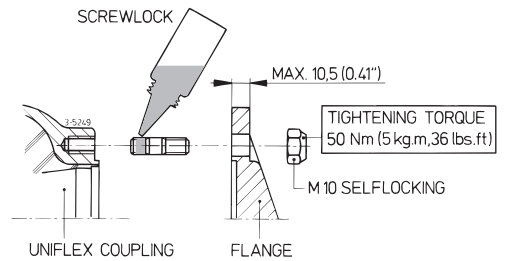
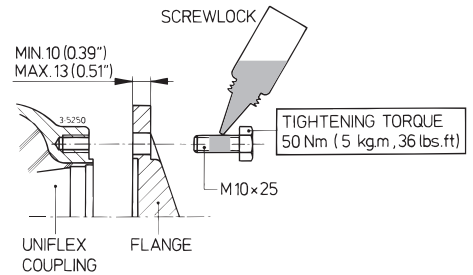

To achieve a reliably operating coupling all the bolts and nuts must be tightened with the torques given. Use a torque wrench; tightening it 'in the blind' will not lead to satisfying results. ◀

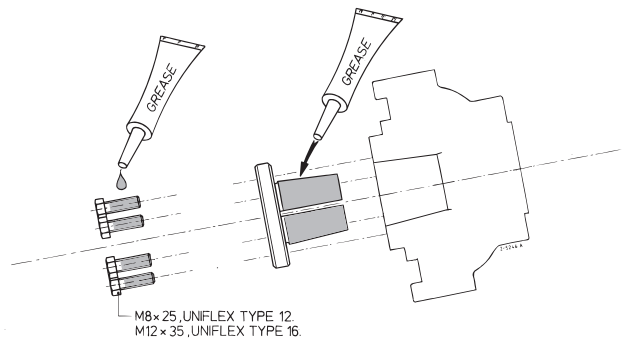
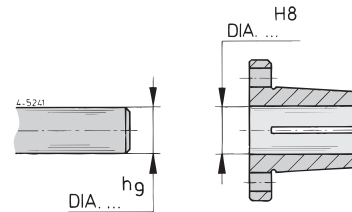

Grease the outside of the taper and the bolts. ◀

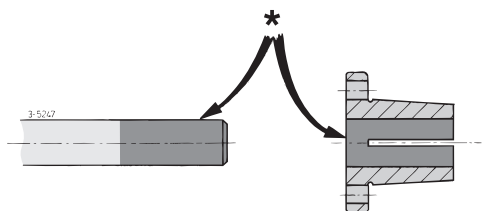

To prevent slipping between the clamping-joint and the propeller shaft, they must be free of grease and dirt (*). ◀

Take care that the rubber parts are not affected by solvents. ◀

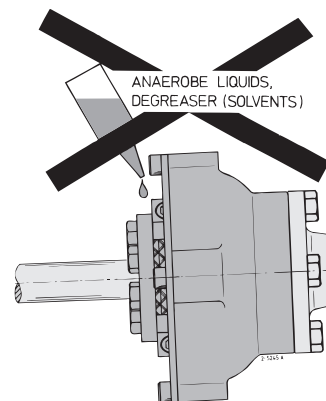

Disassembling

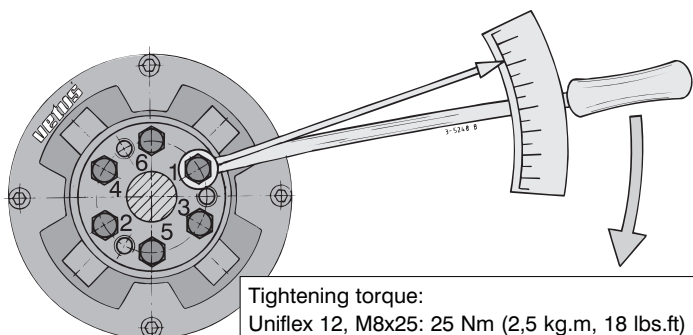
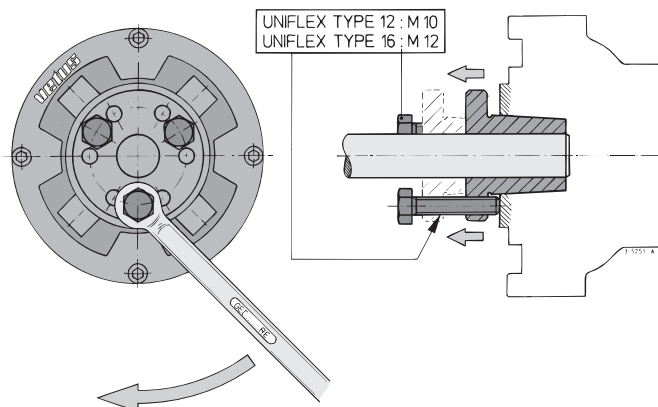

Tightening torque:
Uniflex 12, M8x25: 25 Nm (2,5 kg.m, 18 lbs.ft)
Uniflex 16, M12x35: 90 Nm (9,0 kg.m, 52 lbs.ft)

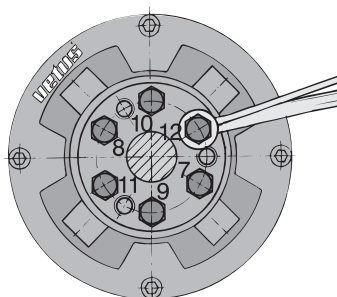

The numbers indicate the sequence in which the bolts have to be tightened.
If necessary, tighten the bolts again. ◀

Technical data

| Uniflex | | 12 | | 16 | |
|--------------------------|-----------------|--|-------------------|---|-------------------|
| | | | | | |
| Weight | : | 2,8 kg | 6.2 lbs | 6,9 kg | 15.2 lbs |
| Max. torque to DIN6270B | : | 200 N.m | 144.6 lbs.ft | 400 N.m | 289.3 lbs.ft |
| Max. torque to DIN6270A | : | 175 N.m | 126.5 lbs.ft | 350 N.m | 253.1 lbs.ft |
| Max. power to DIN6270B * | : | 2,1 kW/100 min ⁻¹ | 2.8 hp/100 RPM | 4,2 kW/100 min ⁻¹ | 5.6 hp/100 RPM |
| Max. power to DIN6270A * | : | 1,8 kW/100 min ⁻¹ | 2.5 hp/100 RPM | 3,6 kW/100 min ⁻¹ | 5 hp/100 RPM |
| Mass moment of inertia | J | 399 . 10 ⁻⁵ kg.m ² | | 1723 . 10 ⁻⁵ kg.m ² | |
| | GD ² | 0,016 kgf.m ² | | 0,069 kgf.m ² | |
| Dyn. torsional stiffness | : | 900 N.m/rad | 8.63 °/100 lbs.ft | 1900 N.m/rad | 4.09 °/100 lbs.ft |
| Axial pull stiffness | : | 1,7 kN/mm | 0.0105 "/100 lbs | 1,9 kN/mm | 0.0094 "/100 lbs |
| Axial push stiffness | : | 2,8 kN/mm | 0.0064 "/100 lbs | 5,3 kN/mm | 0.0034 "/100 lbs |
| Max. rpm at | 2° ** | 1500 min ⁻¹ | 1500 RPM | 1500 min ⁻¹ | 1500 RPM |
| | 0° | 4500 min ⁻¹ | 4500 RPM | 3500 min ⁻¹ | 3500 RPM |

* Max. Power $P_{max} = M_{max} \cdot 2 \cdot \pi \cdot n$ (M_{max} is the max. torque and n the RPM)

** Maximum angular displacement for both Uniflex models is 2°.

Aufstellung

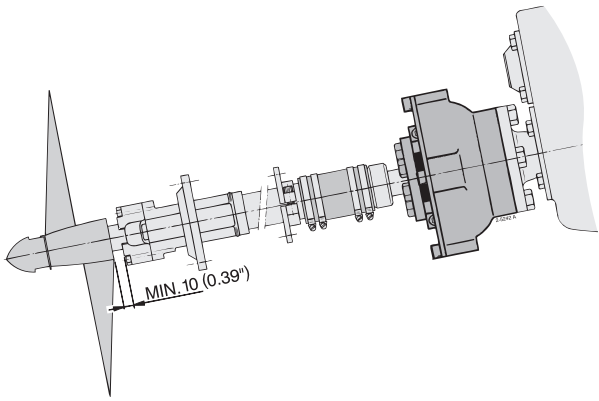

Aufgrund der Achsialbewegung der Schraubenwelle muß zwischen dem äußeren Wellenlager und der Nabe der Schiffsschraube ein minimaler freier Raum sein. ◀

Schubkraft

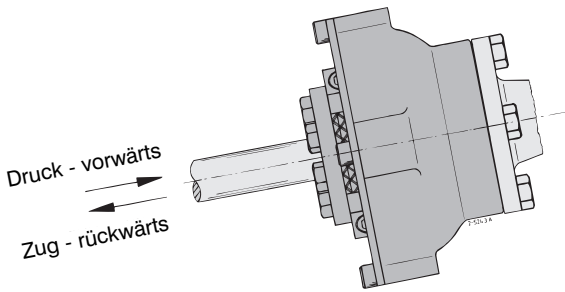

Achtung: Beim Vorwärtsfahren soll das Gummitteil zusammengedrückt werden. ◀

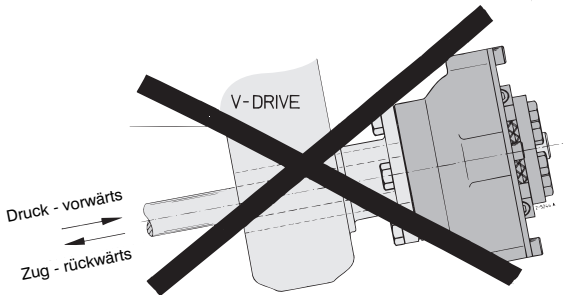

Der Einsatz der Uniflex in Kombination mit einem Vdrive-Wendegertriebe ist nicht gestattet! ◀

Abweichender (größerer) durchmesser der schraubenwelle

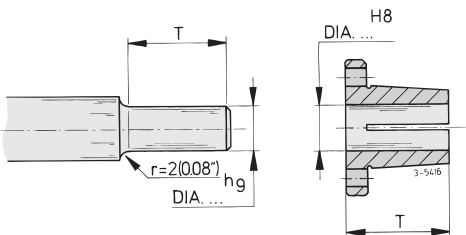

Den Durchmesser der Schraubenwelle über die Länge der Klemmbuchse (Maß 'A') auf Maß 'd' der Kupplung verkleinern, siehe 'Hauptabmessungen'. Radius 'r' sollte mindestens 2 mm betragen. ◀

Versatz

Der max. zulässiger Versatz der Schraubenwelle beträgt 2°. ◀

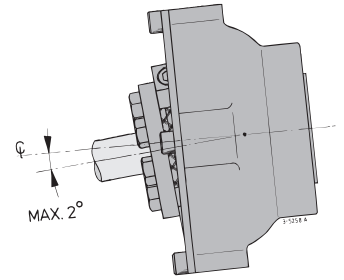

Montage allgemein

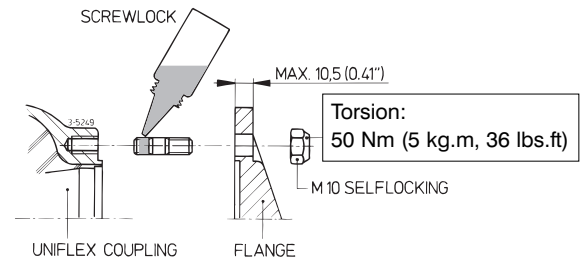
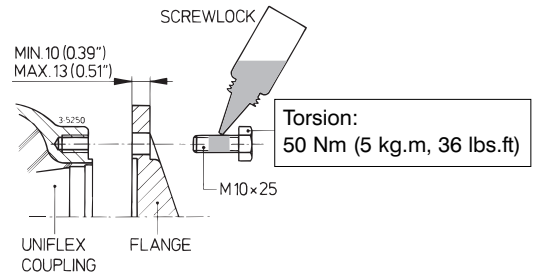

Damit eine zuverlässig funktionierende Kupplung erreicht wird, sollten alle Bolzen und Muttern nach den angegebenen Drehmomenten angezogen werden. Verwenden Sie dazu einen Drehmomentschlüssel; das 'Anziehen nach Gefühl' führt nicht zu befriedigenden Ergebnissen. ◀

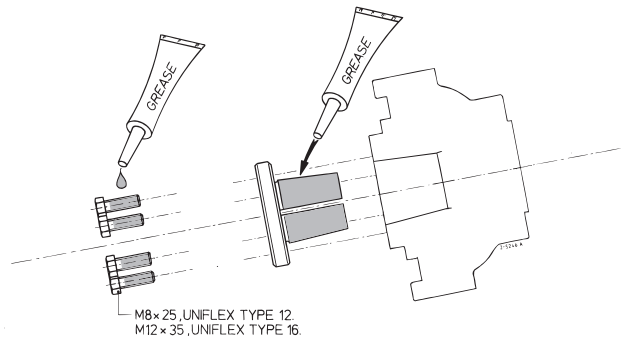
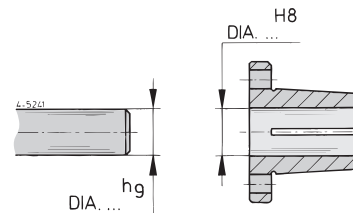

Fetten Sie die Außenseite der Klemmbuchse und der Bolzen ein. ◀

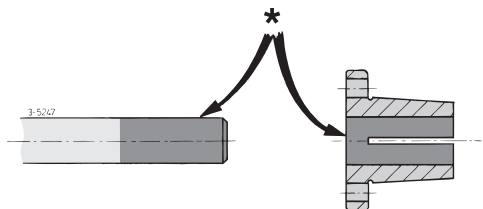

Um Schlupf zwischen Klemmnabe und Schraubenwelle zu verhindern, müssen diese schmutz- und fettfrei (*) sein. ◀

Sorgen Sie dafür, daß die Gummitteile nicht von Lösungsmitteln angegriffen werden. ◀

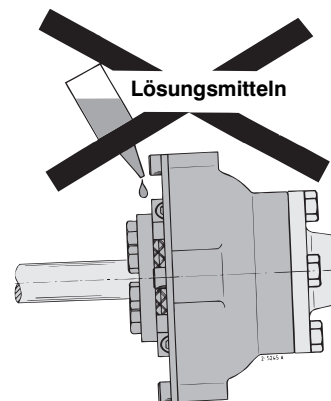

Ausbauen

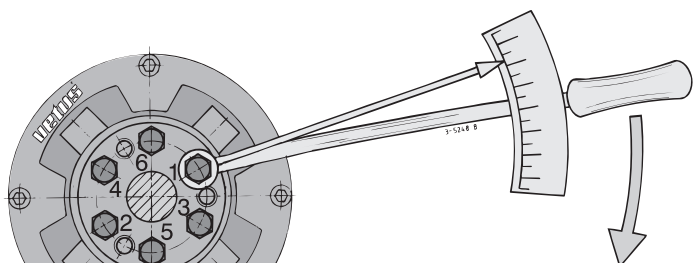

Torsion:
Uniflex 12, M8x25: 25 Nm (2,5 kg.m, 18 lbs.ft)
Uniflex 16, M12x35: 90 Nm (9,0 kg.m, 52 lbs.ft)

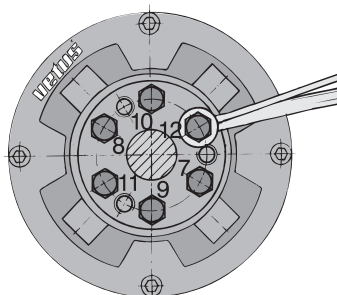

Die Nummern geben die Reihenfolge an, in die Bolzen angezogen werden müssen. Wenn nötig, alle Bolzen nochmals nachziehen. ◀

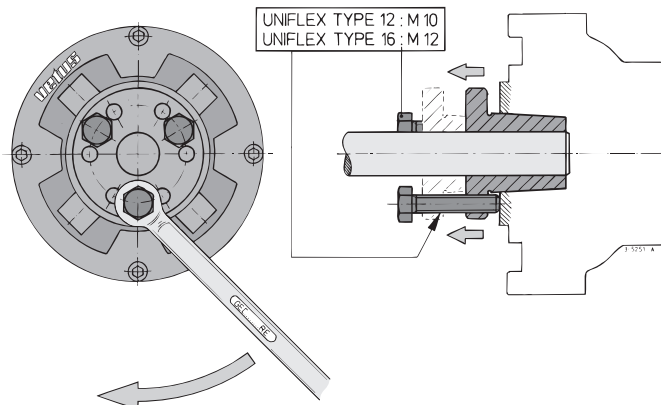

Technische Daten

| Uniflex | : | 12 | 16 |
|-------------------------------|-----------------|--|---|
| Gewicht | : | 2,8 kg | 6,9 kg |
| Max. Drehmoment gem. DIN6270B | : | 200 N.m | 400 N.m |
| | | 20 kgf.m | 40 kgf.m |
| Max. Drehmoment gem. DIN6270A | : | 175 N.m | 350 N.m |
| | | 17,5 kgf.m | 35 kgf.m |
| Max. Leistung gem. DIN6270B * | : | 2,1 kW/100 min ⁻¹ | 4,2 kW/100 min ⁻¹ |
| | | 2.8 hp/100 RPM | 5.6 hp/100 RPM |
| Max. Leistung gem. DIN6270A * | : | 1,8 kW/100 min ⁻¹ | 3,6 kW/100 min ⁻¹ |
| | | 2.5 hp/100 RPM | 5 hp/100 RPM |
| Massenträgheitsmoment | J | 399 · 10 ⁻⁵ kg.m ² | 1723 · 10 ⁻⁵ kg.m ² |
| | GD ² | 0,016 kgf.m ² | 0,069 kgf.m ² |
| Dyn. Drehsteifigkeit | : | 900 N.m/rad | 1900 N.m/rad |
| | | 6,37 °/100 N.m | 3,02 °/100 N.m |
| Axiale steifigkeit zug | : | 1,7 kN/mm | 1,9 kN/mm |
| | | 170 kgf/mm | 190 kgf/mm |
| Axiale steifigkeit druck | : | 2,8 kN/mm | 5,3 kN/mm |
| | | 280 kgf/mm | 530 kgf/mm |
| Max. Drehzahl bei | 2° ** | 1500 min ⁻¹ | 1500 min ⁻¹ |
| | 0° | 4500 min ⁻¹ | 3500 min ⁻¹ |
| | | 1500 RPM | 1500 RPM |
| | | 4500 RPM | 3500 RPM |

* Max. Leistung $P_{max} = M_{max} \cdot 2 \cdot \pi \cdot n$ (M_{max} ist das max. Drehmoment und n die Drehzahl)

** Maximale Winkelverschiebung für beide Typen Uniflex ist 2°.

Montage

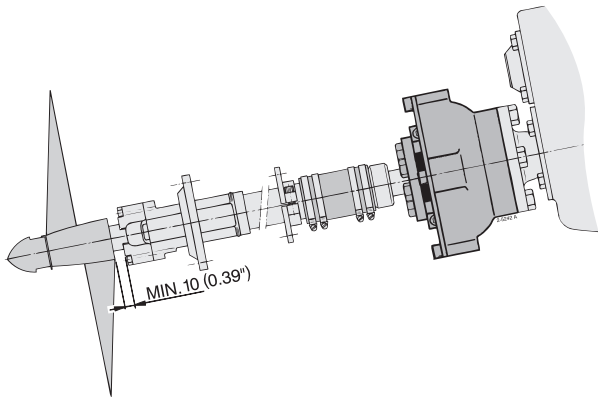

Etant donné le mouvement axial de l'arbre porte-hélice, il est nécessaire de laisser un espace libre minimum entre le support extérieur et le moyeu de l'hélice. ◀

Force de propulsion

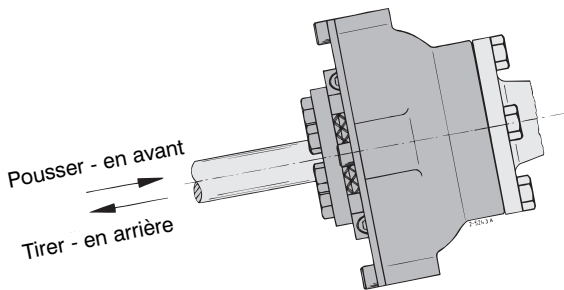

N.B. Lors de la marche avant, la partie caoutchouc doit être comprimée. ◀

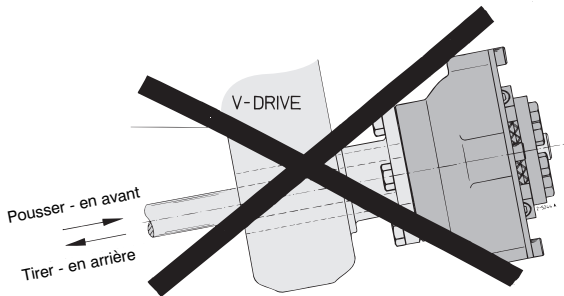

Il est interdit d'utiliser le Uniflex en combinaison avec un inverseur à entraînement en V ! ◀

Autre diamètre (plus grand) de l'arbre porte-hélice

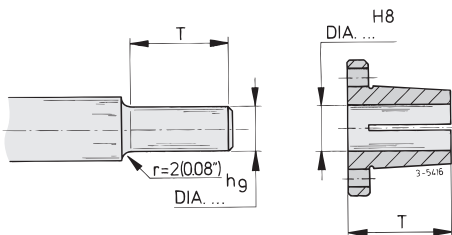

Réduire, sur la longueur de la bague de serrage (dimension 'A'), le diamètre de l'arbre porte-hélice à la dimension 'd' du couplage. Voir les 'dimensions principales'. Rayon 'r' minimum 2 mm. ◀

Desalignement

Le désalignement maximum autorisé de l'arbre porte-hélice est de 2°. ◀

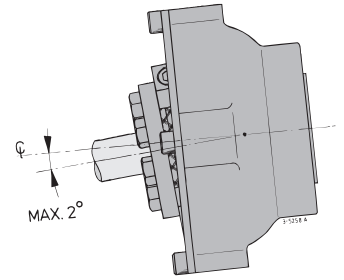

Assemblage generalites

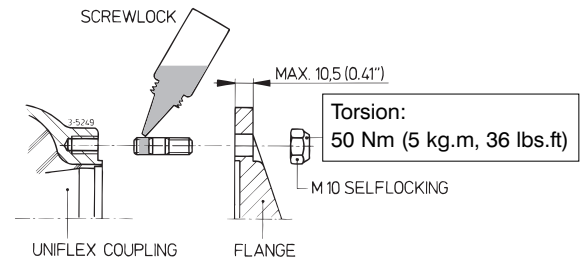
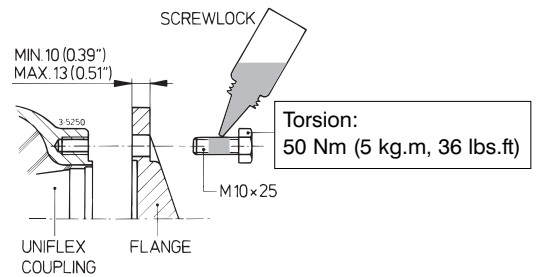

Pour obtenir un accouplement au fonctionnement fiable, il est nécessaire de serrer tous les boulons et écrous selon les moments indiqués. Utiliser pour cela une clef dynamométrique; un serrage approximatif ne donne pas de résultats satisfaisants. ◀

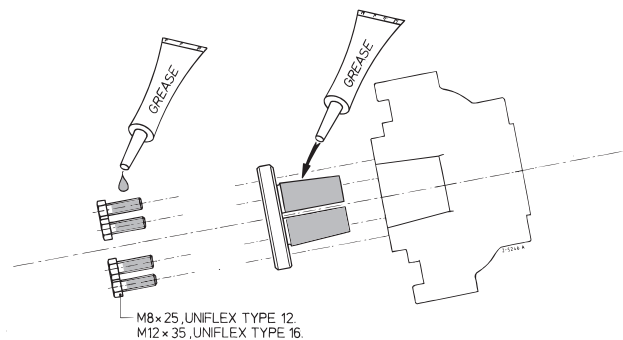
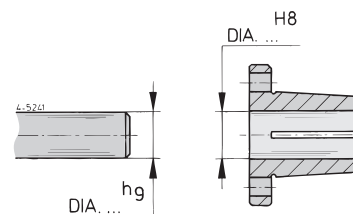

Graisser la partie extérieure du cône de serrage et des boulons. ◀

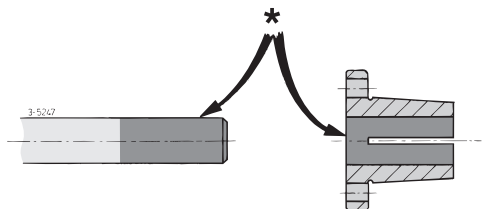

Pour éviter tout glissement entre le moyeu de serrage et l'arbre porte-hélice, veiller à ce que ceux-ci soient exempts de graisse et de saleté (*). ◀

Veiller à ce que les parties caoutchouc ne soient pas attaquées par des solvants. ◀

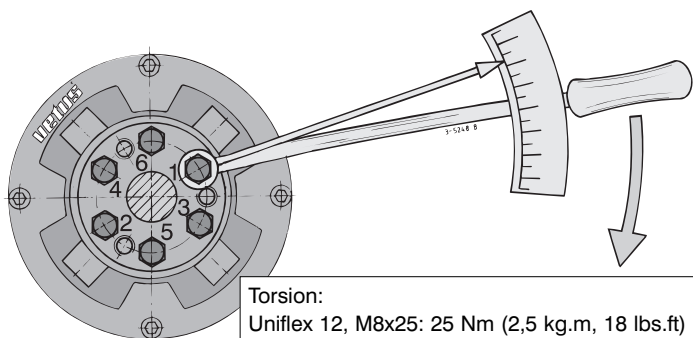
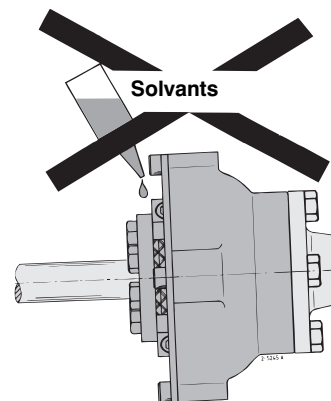

Torsion:
Uniflex 12, M8x25: 25 Nm (2,5 kg.m, 18 lbs.ft)
Uniflex 16, M12x35: 90 Nm (9,0 kg.m, 52 lbs.ft)

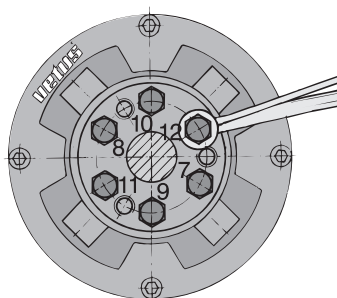

Les numéros indiquent l'ordre dans lequel les boulons doivent être serrés.
Serrer encore une fois tous les boulons si nécessaire. ◀

Demontage

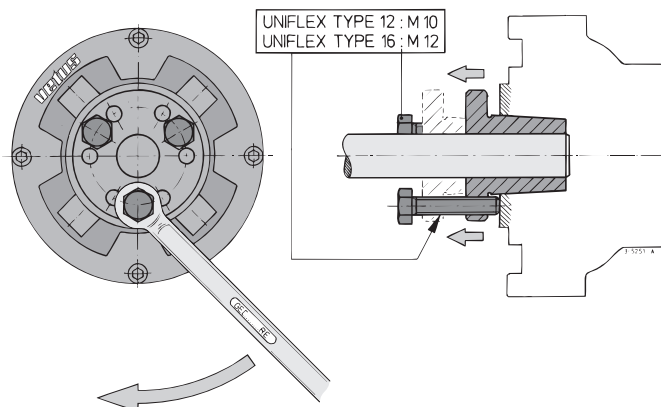

Specifications techniques

| Uniflex | : | 12 | 16 |
|---------------------------------|-----------------|--|---|
| Poids | : | 2,8 kg | 6,9 kg |
| Couple max. selon DIN6270B | : | 200 N.m | 400 N.m |
| | | 20 kgf.m | 40 kgf.m |
| Couple max. selon DIN6270A | : | 175 N.m | 350 N.m |
| | | 17,5 kgf.m | 35 kgf.m |
| Puissance max. selon DIN6270B * | : | 2,1 kW/100 min ⁻¹ | 4,2 kW/100 min ⁻¹ |
| | | 2.8 hp/100 RPM | 5.6 hp/100 RPM |
| Puissance max. selon DIN6270A * | : | 1,8 kW/100 min ⁻¹ | 3,6 kW/100 min ⁻¹ |
| | | 2.5 hp/100 RPM | 5 hp/100 RPM |
| Moment d'inertie | J | 399 . 10 ⁻⁵ kg.m ² | 1723 . 10 ⁻⁵ kg.m ² |
| | GD ² | 0,016 kgf.m ² | 0,069 kgf.m ² |
| Rigidite dyn. a la torsion | : | 900 N.m/rad | 1900 N.m/rad |
| | | 6,37 °/100 N.m | 3,02 °/100 N.m |
| Rigidite axiale de tracción | : | 1,7 kN/mm | 1,9 kN/mm |
| | | 170 kgf/mm | 190 kgf/mm |
| Rigidite axiale de compresión | : | 2,8 kN/mm | 5,3 kN/mm |
| | | 280 kgf/mm | 530 kgf/mm |
| Nombre de tours max. á | 2° ** | 1500 min ⁻¹ | 1500 min ⁻¹ |
| | 0° | 4500 min ⁻¹ | 3500 min ⁻¹ |
| | | 1500 RPM | 1500 RPM |
| | | 4500 RPM | 3500 RPM |

* Puissance max. $P_{max} = M_{max} \cdot 2 \cdot \pi \cdot n$ (M_{max} est le couple max. et n le nombre de tours)

** Le déplacement angulaire maximum pour les deux types Uniflex est de 2°.

Montaje

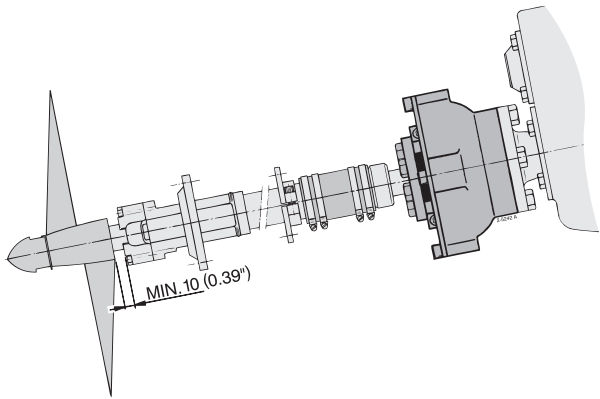

Dado el movimiento axial del árbol porta-hélice, es necesario dejar un espacio libre mínimo entre el soporte exterior y el cubo de hélice. ◀

Fuerza de propulsión

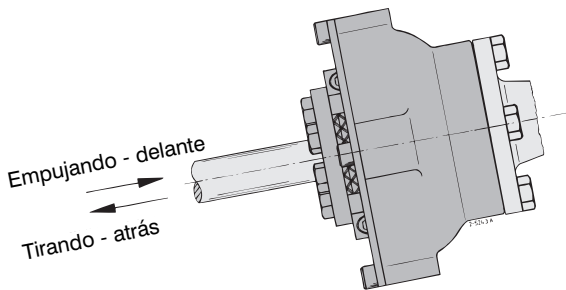

Nota: ¡Navegando hacia delante la parte de caucho se debe comprimir! ◀

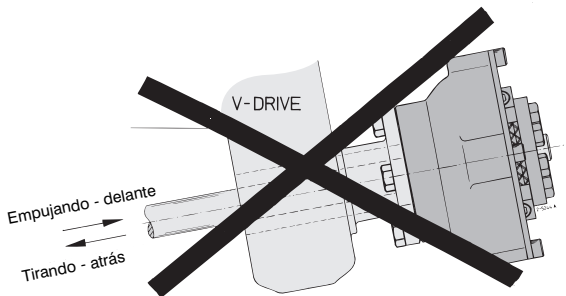

¡No se permite aplicar el Uniflex en combinación con la caja de velocidades del tipo de transmisión en V! ◀

Otro diámetro (mayor) del árbol porta-hélice

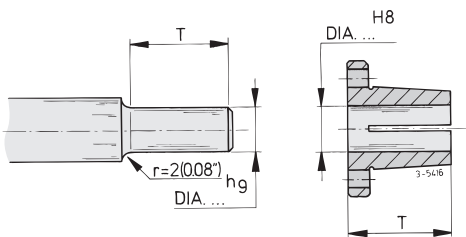

Redúzcase el diámetro del árbol porta-hélice a lo largo del cono (dimensión 'A') hacia dimensión 'd' del acoplamiento, véanse las 'Dimensiones Principales'. El radio 'r' será de 2 mm como mínimo. ◀

Mal alineamiento

Se admite un mal alineamiento máximo de 2° del árbol porta-hélice. ◀

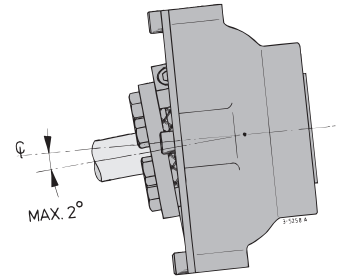

Montaje en general

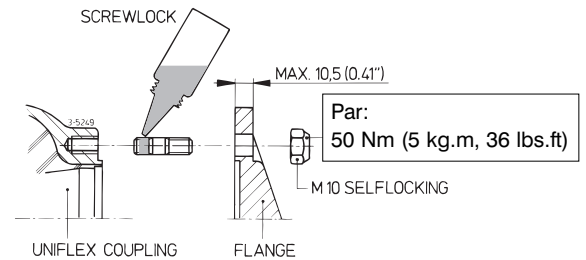
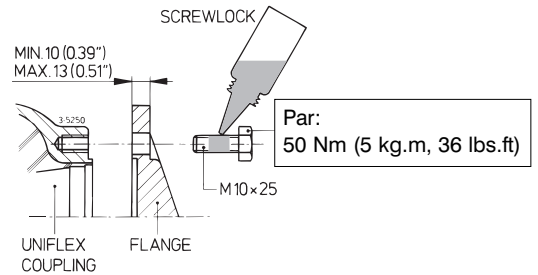

Para obtener una acoplamiento de funcionamiento fiable se apretarán todos los tornillos y tuercas según los pares indicados. Utilizar para ello una llave de torsión; apretar 'a tuestas' no dará resultados satisfactorios. ◀

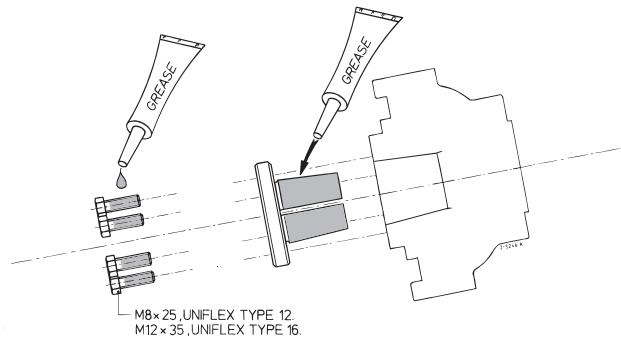
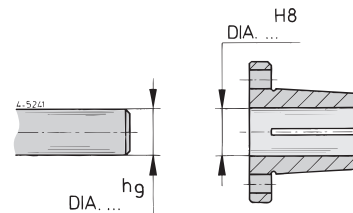

Engrase el exterior del cono de sujeción y de los tornillos. ◀

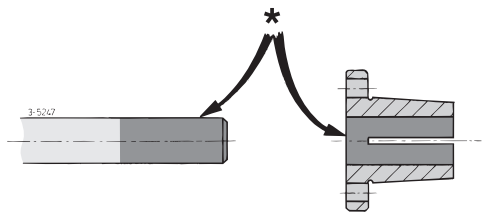

Para evitar holgura entre el cubo de sujeción y el eje de hélice, los mismos han de estar sin grasa y suciedad (*). ◀

Asegurar que las partes de caucho no sean afectadas por disolventes. ◀

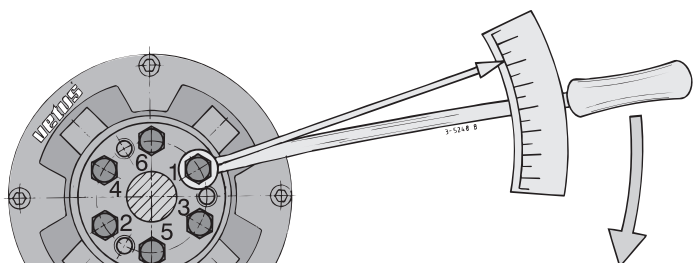
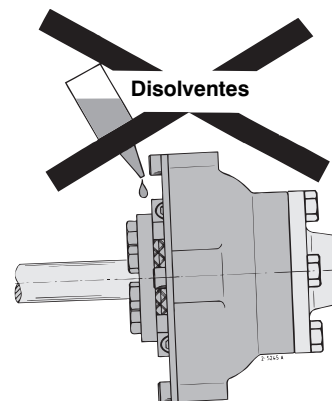

Par:
Uniflex 12, M8x25: 25 Nm (2,5 kg.m, 18 lbs.ft)
Uniflex 16, M12x35: 90 Nm (9,0 kg.m, 52 lbs.ft)

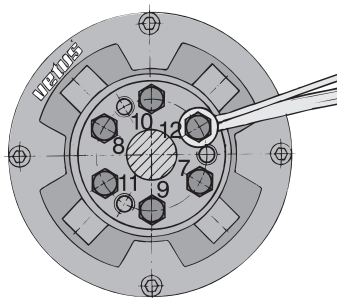

Los números indican el orden de apriete de los tornillos. Si fuera necesario, vuelva a apretar todos los tornillos. ◀

Desmontaje

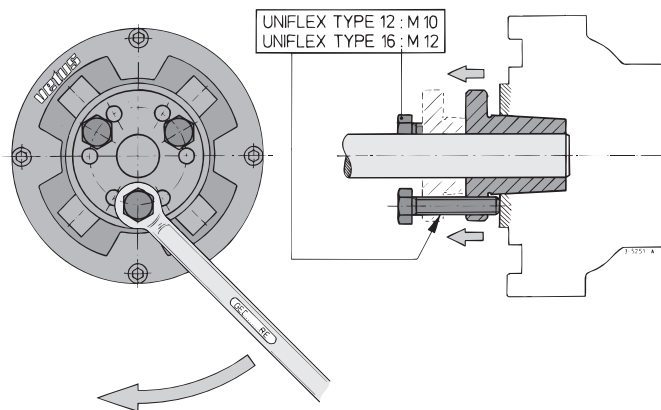

Especificaciones técnicas

| Uniflex | : | 12 | 16 |
|---------------------------------------|-----------------|---|---|
| Peso | : | 2,8 kg | 6,9 kg |
| Pár máximo según DIN6270B | : | 200 N.m 20 kgf.m | 400 N.m 40 kgf.m |
| Pár máximo según DIN6270A | : | 175 N.m 17,5 kgf.m | 350 N.m 35 kgf.m |
| Potencia máxima según DIN6270B * | : | 2,1 kW/100 min ⁻¹ 2.8 hp/100 RPM | 4,2 kW/100 min ⁻¹ 5.6 hp/100 RPM |
| Potencia máxima según DIN6270A * | : | 1,8 kW/100 min ⁻¹ 2.5 hp/100 RPM | 3,6 kW/100 min ⁻¹ 5 hp/100 RPM |
| Momento de inercia | J | 399 . 10 ⁻⁵ kg.m ² | 1723 . 10 ⁻⁵ kg.m ² |
| | GD ² | 0,016 kgf.m ² | 0,069 kgf.m ² |
| Rigidez dyn. de torsión | : | 900 N.m/rad 6,37 °/100 N.m | 1900 N.m/rad 3,02 °/100 N.m |
| Rigidite axiale a la traction | : | 1,7 kN/mm 170 kgf/mm | 1,9 kN/mm 190 kgf/mm |
| Rigidite axiale a la compression | : | 2,8 kN/mm 280 kgf/mm | 5,3 kN/mm 530 kgf/mm |
| Número de revoluciones máx. con 2° ** | : | 1500 min ⁻¹ 1500 RPM | 1500 min ⁻¹ 1500 RPM |
| | 0° | 4500 min ⁻¹ 4500 RPM | 3500 min ⁻¹ 3500 RPM |

* Potencia máxima: $P_{max} = M_{max} \cdot 2 \cdot P \cdot n$ (siendo 'M_{max}' el par máximo y 'n' el número de revoluciones)

** El desplazamiento máximo de ángulo para ambos tipos de Uniflex es de 2°.

Montaggio

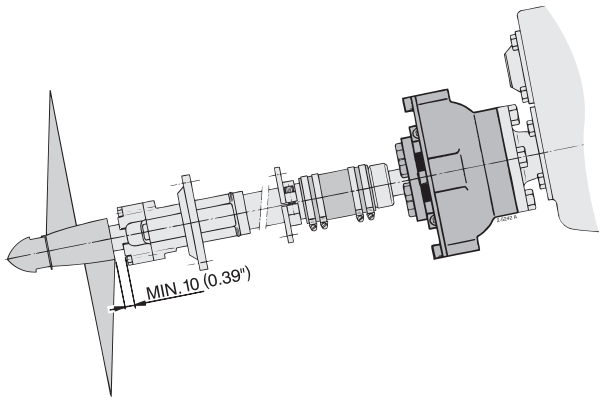

Tenendo conto del movimento assiale dell'albero dell'elica, è necessario lasciare uno spazio libero minimo fra la sospensione esterna e il mozzo dell'elica. ◀

Forza di propulsione

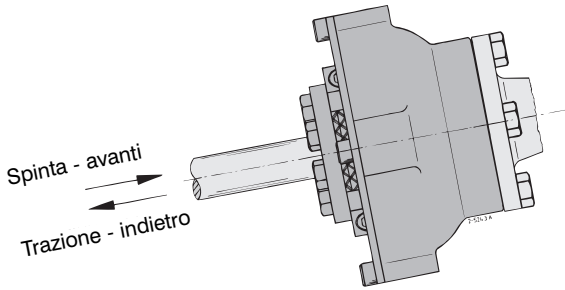

N.B. Durante la marcia in avanti la parte in gomma deve essere premuta! ◀

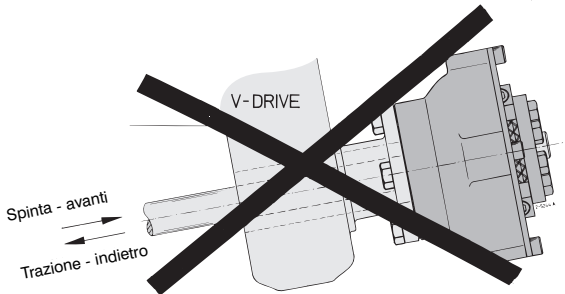

L'uso del Uniflex in combinazione con una trasmissione tipo V-drive non è permesso! ◀

Diametro diverso (più grande) dell'albero dell'elica

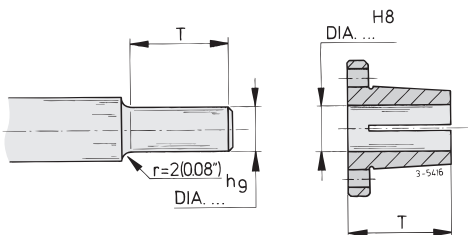

Ridurre il diametro dell'albero dell'elica sulla lunghezza del fermo (dimensione 'A') fino a raggiungere la dimensione 'd' dell'accoppiamento, vedi 'Dimensioni Principali'. Raggio 'r' minimo 2 mm. ◀

Errore di allineamento

L'errore di allineamento massimo consentito dell'albero dell'elica è di 2°. ◀

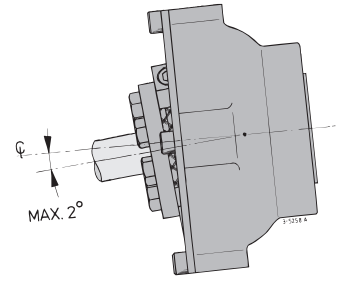

Montaggio, generalità

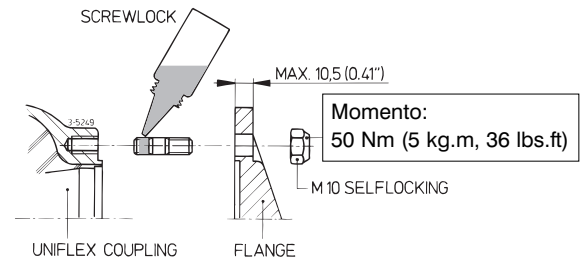
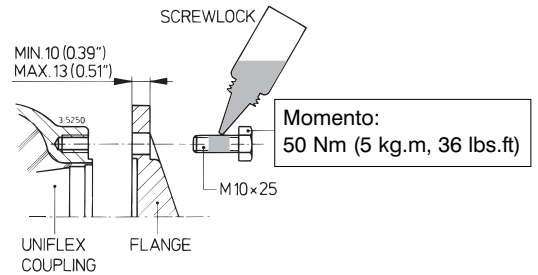

Per ottenere un giunto di accoppiamento che funzioni in modo affidabile, tutti i bulloni e tutti i dadi devono essere avvitati con il momento indicato. A questo scopo utilizzare una chiave dinamometrica; avvitando in modo approssimativo non si ottengono risultati soddisfacenti. ◀

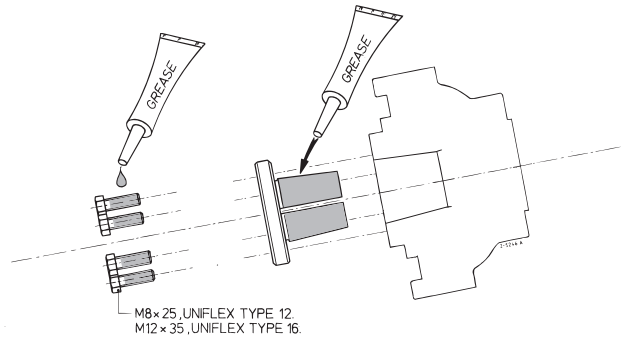
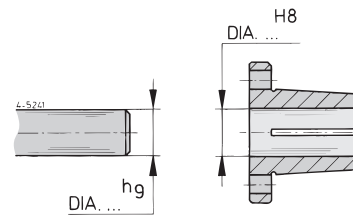

Lubrificare la superficie esterna del cono di bloccaggio e dei bulloni. ◀

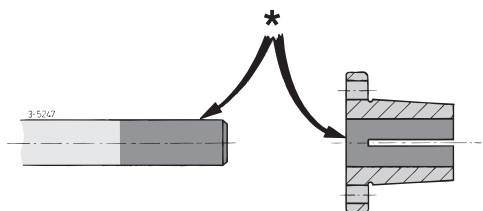

Il mozzo e l'albero dell'elica devono essere privi di grasso e sporco (*), onde evitare che slittino tra loro. ◀

Assicurarsi che le parti in gomma non vengano corrose dai solventi. ◀

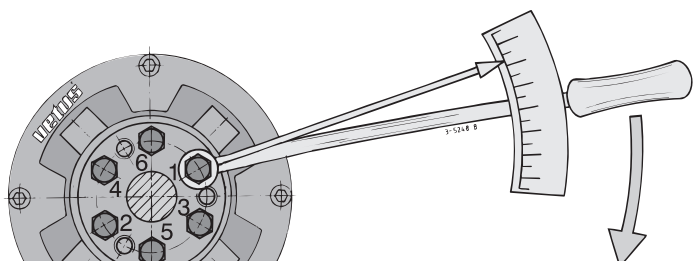
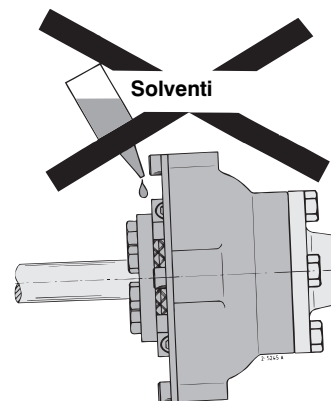

Momento:
Uniflex 12, M8x25: 25 Nm (2,5 kg.m, 18 lbs.ft)
Uniflex 16, M12x35: 90 Nm (9,0 kg.m, 52 lbs.ft)

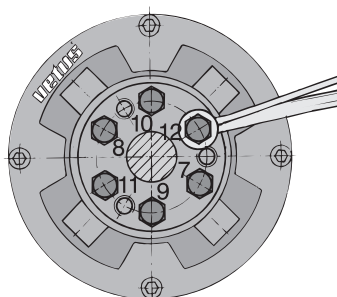

I numeri indicano la sequenza di serraggio dei bulloni. Se necessario, serrare tutti i bulloni una seconda volta. ◀

Smontaggio

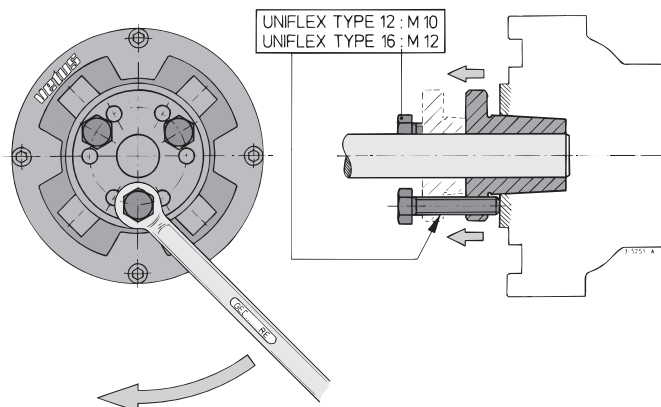

Dati tecnici

| Uniflex | : | 12 | 16 |
|------------------------------------|-----------------|--|---|
| Peso | : | 2,8 kg | 6,9 kg |
| Momento max. secondo DIN6270B | : | 200 N.m | 400 N.m |
| | | 20 kgf.m | 40 kgf.m |
| Momento max. secondo DIN6270A | : | 175 N.m | 350 N.m |
| | | 17,5 kgf.m | 35 kgf.m |
| Potenza max. secondo DIN6270B * | : | 2,1 kW/100 min ⁻¹ | 4,2 kW/100 min ⁻¹ |
| | | 2.8 hp/100 RPM | 5.6 hp/100 RPM |
| Potenza max. secondo DIN6270A * | : | 1,8 kW/100 min ⁻¹ | 3,6 kW/100 min ⁻¹ |
| | | 2.5 hp/100 RPM | 5 hp/100 RPM |
| Momento d'inerzia | J | 399 . 10 ⁻⁵ kg.m ² | 1723 . 10 ⁻⁵ kg.m ² |
| | GD ² | 0,016 kgf.m ² | 0,069 kgf.m ² |
| Rigidità torsionale din. | : | 900 N.m/rad | 1900 N.m/rad |
| | | 6,37 °/100 N.m | 3,02 °/100 N.m |
| Rigidità assiale alla trazione | : | 1,7 kN/mm | 1,9 kN/mm |
| | | 170 kgf/mm | 190 kgf/mm |
| Rigidità assiale alla compressione | : | 2,8 kN/mm | 5,3 kN/mm |
| | | 280 kgf/mm | 530 kgf/mm |
| Numero max. di giri a | 2° ** | 1500 min ⁻¹ | 1500 min ⁻¹ |
| | 0° | 4500 min ⁻¹ | 3500 min ⁻¹ |
| | | 1500 RPM | 1500 RPM |
| | | 4500 RPM | 3500 RPM |

* Potenze massima: $P_{max} = M_{max} \cdot 2 \cdot P \cdot n$ (dove M_{max} indica la coppia massima ed 'n' il numero di giri)

** Lo spostamento angolare massimo per entrambi i modelli Uniflex è 2°

Hoofdafmetingen

Hauptabmessungen

Dimensiones principales

Overall dimensions

Dimensions principales

Dimensioni principali

UNIFLEX12

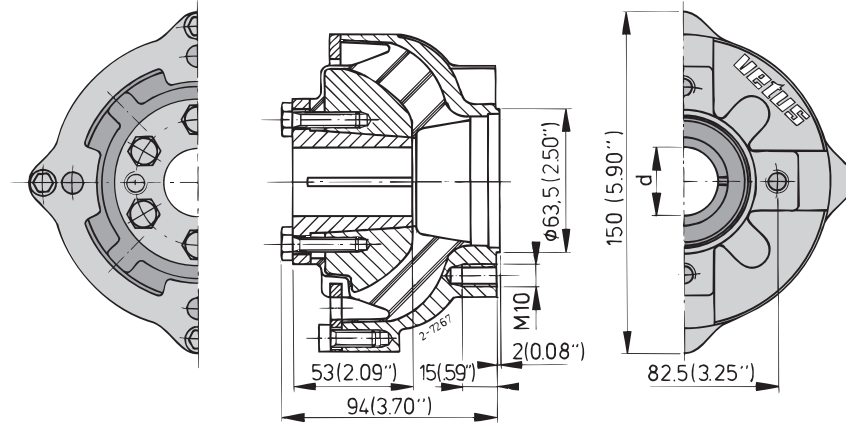

| d |
|-------|
| 20 mm |
| 25 mm |
| 30 mm |

UNIFLEX16

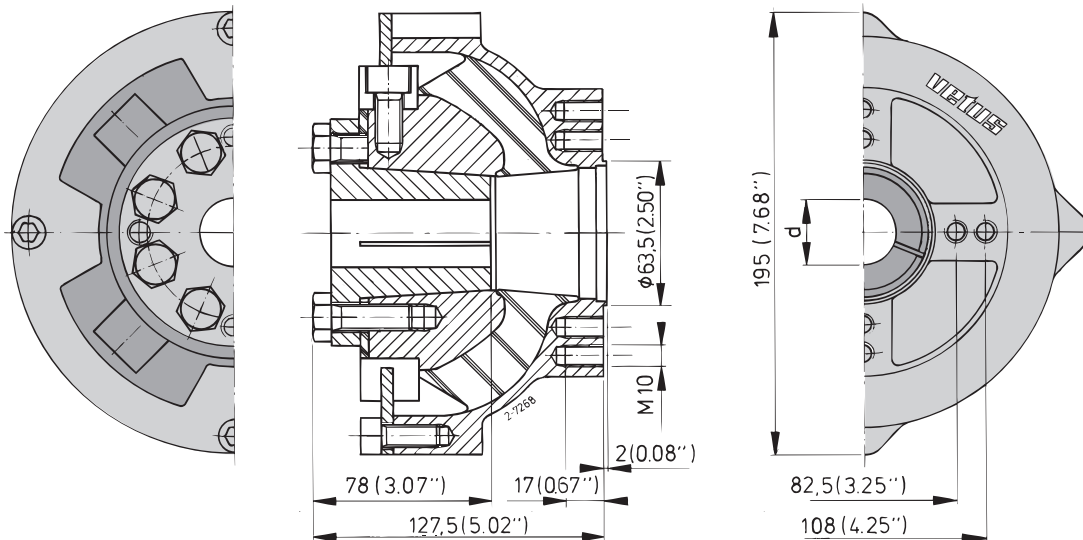

| d |
|-------|
| 30 mm |
| 35 mm |
| 40 mm |

Verloopflenzen

Zwischenflanschen

Bridas de adaptación

Adapter flanges

Brides d'adaptation

Flange di adattamento

FLANGE1

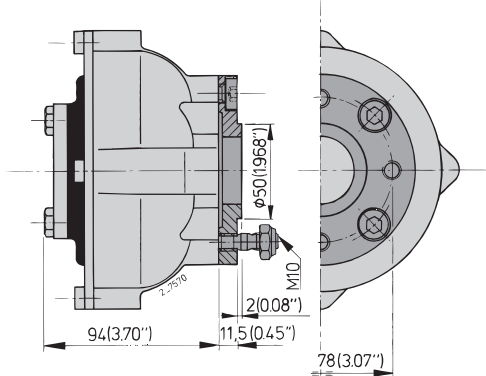

- KANZAKI KC30
 KC45
 KC100
- YANMAR KM2C
 KM2P
 KM3A
 KM3P

FLANGE2

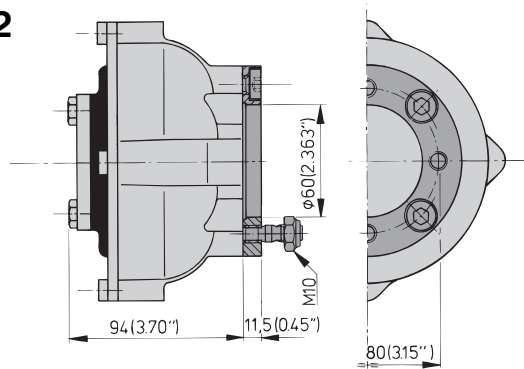

- VOLVO MS10A MS10L
 MS15A MS15L
 MS25A MS25L

FLANGE2A

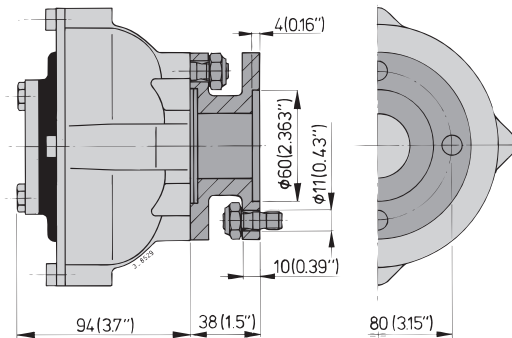

- VOLVO MS
 MSB
 MS2

FLANGE3

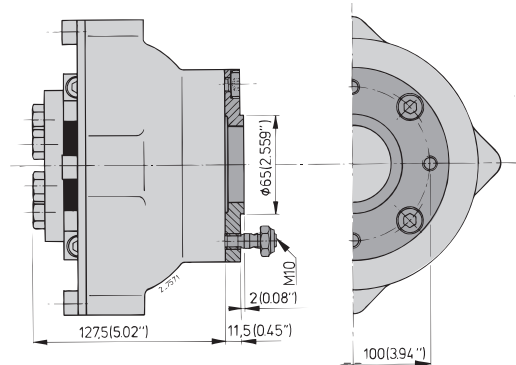

- KANZAKI KC180
- YANMAR KM4A
 KM4A1
 KMH4A
 KBW20-1
 KBW21

vetus den ouden n.v.

FOKKERSTRAAT 571 - 3125 BD SCHIEDAM - HOLLAND - TEL.: +31 10 4377700 - TELEX: 23470
TELEFAX: +31 10 4372673 - 4621286 - E-MAIL: sales@vetus.nl - INTERNET: <http://www.vetus.nl>

Printed in the Netherlands

3.0203 I.UNIFL 01-91 Rev. 01-94, 11-00, 12-02, 08-04