



**USER MANUAL
INSTALLATION MANUAL**

Isolation transformers

**ITR000702000
Isolation Transformer 7000 W 230V/32A**

Victron Energy B.V.
The Netherlands
General phone: +31 (0)36 535 97 00
Customer support desk: +31 (0)36 535 97 77
General and Service fax: +31 (0)36 531 16 66
Sales fax: +31 (0)36 535 97 40
E-mail: sales@victronenergy.com
Internet site: <http://www.victronenergy.com>

Table of contents

- 1. Important safety instructions**
 - 1.1. General safety precautions
 - 1.2. Safety: Installation
- 2. Installation**
 - 2.1. Connection
 - 2.2. Input earth connection
 - 2.3. Output neutral grounding
- 3. Operation**
 - 3.1. Thermal circuit breaker
 - 3.2. Temperature protection
 - 3.3. Inrush current limiter
- 4. Specifications**

1. Important safety instructions



Warning!

Before installing or using this product, please read and save the safety instructions below.

1.1. General safety precautions

- 1.1.1. Do not expose the isolation transformer to water, mist, snow, spray, or dust.
- 1.1.2. Do not use the product where there is a risk of gas or dust explosions. This product is not ignition protected.
- 1.1.3. Use the product in accordance with specifications as stated in paragraph 4.
- 1.1.4. Do not open the enclosure if the product is still connected to a source of electrical power.

1.2. Safety: Installation

- 1.2.1. Connections and safety features must be according to the locally applicable regulations.
- 1.2.2. This is a Safety Class 1 product (supplied with a protective grounding terminal). Uninterruptible protective grounding must be provided.
- 1.2.3. Use electric cables of the appropriate size.
- 1.2.4. Install the isolation transformer in a well ventilated area.
- 1.2.5. Keep a clear space of 10 cm around the product for ventilation.
- 1.2.6. For safety purposes, the product should be installed in a heat-resistant environment. Avoid the presence of e.g. chemicals, synthetic components, curtains or other textiles in the immediate vicinity of the product.

2. Installation



Warning!
Shock hazard. Do not work on the isolation transformer or the electrical system if still connected to an electrical power source.

2.1. Connection (see fig. 1)

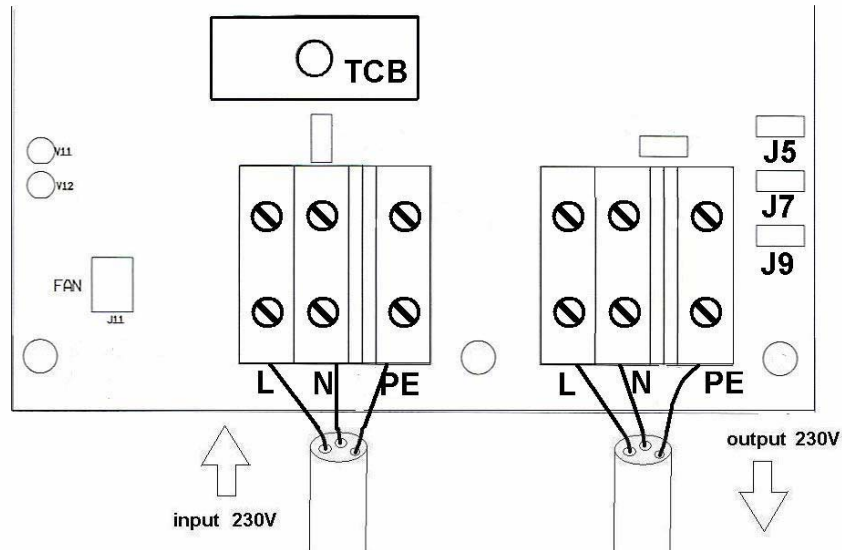

Figure 1: Input and output terminals

- 2.1.1. Pass the shore-side cable through the left side cable gland, at the bottom of the cabinet.
Pass the AC-output cable through the right side cable gland.
- 2.1.2. Connect the shore cable to the terminals indicated with "INPUT".
Connect the green/yellow wire to PE.
Connect the brown wire to L and connect the blue wire to N.

- 2.1.3. Connect the load to the terminals indicated with "OUTPUT".
Connect the green/yellow wire to PE.
Connect the brown wire to L and connect the blue wire to N.
- 2.1.4. Connect the enclosure to ground (= all the metal parts in the boat). This is achieved by establishing a ground connection to the M4 stud on the bottom of the enclosure.
- 2.1.5. Use the following minimal cable cross sections:

230/240 V	6 mm ²	AWG 10
-----------	-------------------	--------

2.2. Input earth connection (fig. 2)

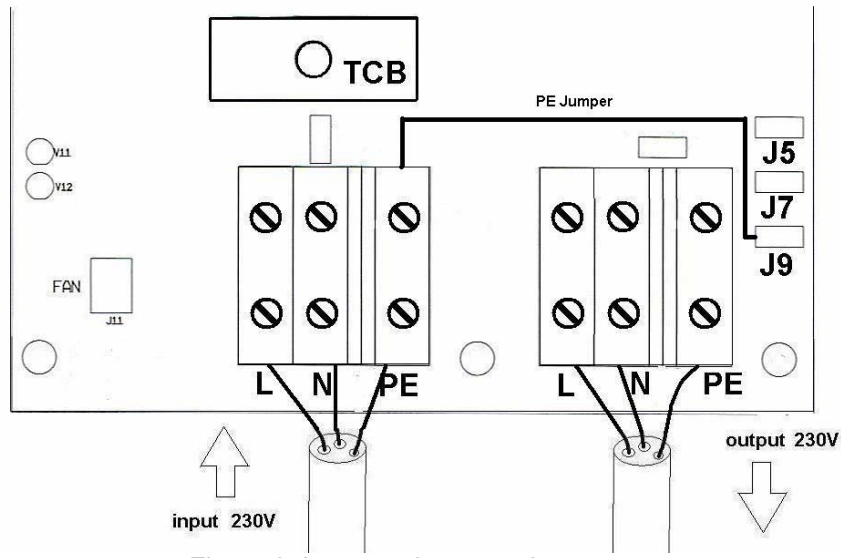

Figure 2: Input earth connection

- If the boat is on shore (winter period or maintenance), the PE conductor in the boat must be connected directly to the input PE, for safety reasons. This is achieved by connecting a PE jumper coming from the input PE terminal to male push-on connector J9 (jumper shown in black in fig. 2). This jumper is provided with the transformer.
- If the boat is floating, remove the PE jumper. Now input and output are isolated from each other.

2.3. Output neutral grounding (fig. 3)

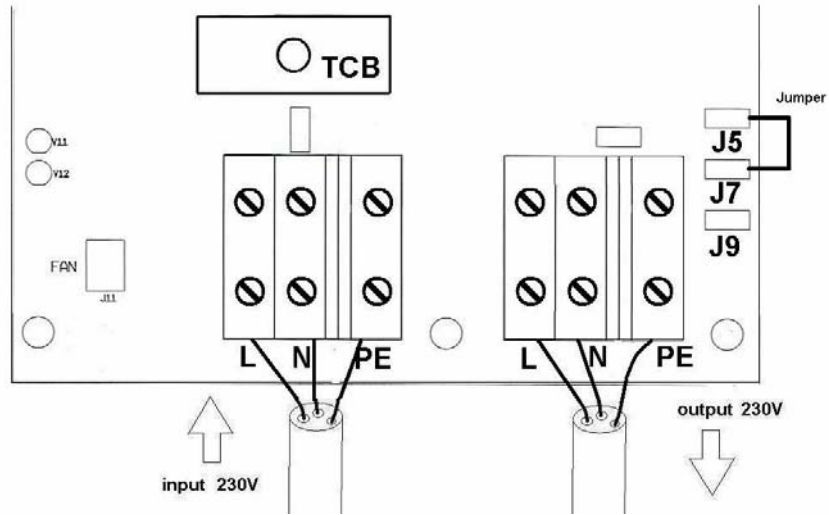

Figure 3: Output neutral grounding

A Residual Current Device (RCD) or Ground Fault Circuit Interrupter (GFCI) must be installed in the output cable of the isolation transformer. For this RCD to operate correctly, the output neutral must be connected to ground (= all the metal parts in the boat). This is achieved by placing a jumper on male push-on connectors J5, J7 (see fig. 3), and by grounding the enclosure of the isolation transformer.

(The output of the isolation transformer is floating when the jumper between J5, J7 is removed)

3. Operation

3.1. Thermal circuit breaker

The isolation transformer is fitted with an automatic circuit breaker. This circuit breaker will switch off the isolation transformer in case of overload or short-circuit.

3.2. Temperature protection

The isolation transformer is fan cooled. The fan is temperature controlled.

The isolation transformer will switch off in case of overheating.

3.3. Inrush current limiter

The inrush current limiter prevents upstream circuit breakers or fuses from tripping when switching on the isolation transformer.

4. Specifications

Isolation transformer	7000 Watt
Input and output voltage	230 / 240 V
Frequency	50/60Hz
Rating	32 A
Soft start	Yes
Ambient temperature	-20°C to 40°C
Humidity	Max 95%, non condensing
Transformer type	Toroidal (low noise, low weight)
Enclosure	Aluminium
Input thermal circuit breaker	yes
Protection category	IP21
Safety	EN 60076
Weight	24 kg
Dimensions (h x w x d)	362x258x218 mm