



INSTRUCTION MANUAL

VHF MARINE TRANSCEIVER
IC-M90E

Icom Inc.



IN CASE OF EMERGENCY

If your vessel requires assistance, contact other vessels and the Coast Guard by sending a distress call on Channel 16.

○ **USING CHANNEL 16**

DISTRESS CALL PROCEDURE

1. "MAYDAY MAYDAY MAYDAY."
2. "THIS IS" (name of vessel)
3. Your call sign or other indication of the vessel.
4. "LOCATED AT" (your position)
5. The nature of the distress and assistance required.
6. Any other information which might facilitate the rescue.

RECOMMENDATION

CLEAN THE TRANSCEIVER THOROUGHLY WITH FRESH WATER after exposure to saltwater, and dry it before operation. Otherwise, the transceiver's keys, switches and controllers may become inoperable due to salt crystallization.

NOTE: DO NOT remove the battery pack when cleaning the transceiver thoroughly with fresh water. Water may enter into the transceiver, and damage it.

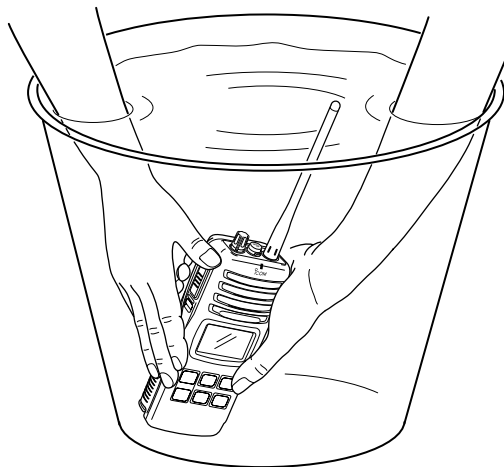

FOREWORD

Thank you for purchasing this Icom radio. The IC-M90E VHF MARINE TRANSCEIVER is designed and built with Icom's state of the art technology and craftsmanship. With proper care this product should provide you with years of trouble-free operation.

IMPORTANT

READ ALL INSTRUCTIONS carefully and completely before using the transceiver.

SAVE THIS INSTRUCTION MANUAL—This instruction manual contains important operating instructions for the IC-M90E.

EXPLICIT DEFINITIONS

WORD	DEFINITION
 WARNING	Personal injury, fire hazard or electric shock may occur.
CAUTION	Equipment damage may occur.
NOTE	If disregarded, inconvenience only. No risk of personal injury, fire or electric shock.

FEATURES

Waterproof construction

Built tough to withstand the punishing marine environment, the IC-M90E meets IPX7 waterproof specification while using BP-223 (option), BP-224 (option) or BP-225. In addition to, the speaker grill adopts a new structure which drains water or seawater easily.

Dualwatch and tri-watch functions

Convenient functions which allow you to monitor the distress channel (Ch 16) while receiving one other channel of your choice (dualwatch), or while receiving one other channel of your choice and the call channel (tri-watch). See p. 14 for details.

Large, easy-to-read LCD

With dimensions of 19(H) × 35(W) mm, the IC-M90E's function display is easy to read and shows operating conditions at a glance. Backlighting and contrast can be adjusted to suit your preferences.

Simple operation

6 large buttons on the front panel provide user-friendly operation. The independent volume and channel buttons are located on the front panel for convenient one-handed operation.

PRECAUTION

⚠ WARNING! NEVER connect the transceiver to an AC outlet. This may pose a fire hazard or result in an electric shock.

⚠ WARNING! NEVER hold the transceiver so that the antenna is closer than 2.5 cm from exposed parts of the body, especially the face or eyes, while transmitting. The transceiver will perform best if the microphone is 5 to 10 cm away from the lips and the transceiver is vertical.

NEVER connect the transceiver to a power source other than the BP-225, BP-224 or BP-223. Such a connection will ruin the transceiver.

AVOID using or placing the transceiver in direct sunlight or in areas with temperatures below -15°C or above $+55^{\circ}\text{C}$: MARINE, -25°C or above $+55^{\circ}\text{C}$: PMR.

KEEP the transceiver out of the reach of children.

KEEP the transceiver at least 0.9 meters away from your vessel's magnetic navigation compass.

MAKE SURE the flexible antenna and battery pack are securely attached to the transceiver, and that the antenna and battery pack are dry before attachment. Exposing the inside of the transceiver to water will result in serious damage to the transceiver.

BE CAREFUL! The IC-M90E employs waterproof construction, which corresponds to IPX7 waterproof specification (1 m depth for 30 min.). However, once the transceiver has been dropped, waterproofing cannot be guaranteed due to the fact that the transceiver may be cracked, or the waterproof seal damaged, etc.

Icom, Icom Inc. and the ICOM logo are registered trademarks of Icom Incorporated (Japan) in the United States, the United Kingdom, Germany, France, Spain, Russia and/or other countries.

TABLE OF CONTENTS

IN CASE OF EMERGENCY	i	6 DUALWATCH/TRI-WATCH	14
RECOMMENDATION	i	■ Description	14
FOREWORD	ii	■ Operation	14
IMPORTANT	ii	7 LAND (PMR) CHANNEL OPERATION	15
EXPLICIT DEFINITIONS	ii	■ LAND (PMR) channel group	15
FEATURES	ii	■ CTCSS and DTCS display	15
PRECAUTION	iii	■ VOX function	15
TABLE OF CONTENTS	iv	8 SET MODE	16–21
1 OPERATING RULES	1	■ SET mode programming	16
2 SUPPLIED ACCESSORIES AND ATTACHMENTS	2–3	■ SET mode items	17
■ Supplied accessories	2	9 BATTERY CHARGING	22–25
■ Attachments	2	■ Battery charging	22
3 PANEL DESCRIPTION	4–6	■ Battery cautions	22
■ Front, top and side panels	4	■ Optional battery case	23
■ Function display	5	■ Optional battery chargers	24
4 BASIC OPERATION	7–11	10 OPTIONAL SWIVEL BELT CLIP	26
■ Channel selection	7	■ MB-86 contents	26
■ Receiving and transmitting	9	■ Attachment	26
■ Call channel programming	10	■ Detachment	26
■ Lock function	10	11 OPTIONAL SPEAKER-MICROPHONE	27
■ Signal strength indicator	10	■ HM-125 descriptions	27
■ Monitor function	10	■ Attachment	27
■ Adjusting the squelch level	11	12 TROUBLESHOOTING	28
■ Backlighting function	11	13 VHF MARINE CHANNEL LIST	29
■ Voice scrambler operation	11	14 SPECIFICATIONS	30
5 SCAN OPERATION	12–13	15 OPTIONS	31
■ Scan types	12	16 QUICK REFERENCE	32
■ Setting tag channels	13	17 ABOUT DOC	34
■ Starting a scan	13		



◇ Priorities

- Read all rules and regulations pertaining to priorities and keep an up-to-date copy handy. Safety and distress calls take priority over all others.
- You must monitor Channel 16 when you are not operating on another channel.
- False or fraudulent distress calls are prohibited under law.

◇ Privacy

- Information overheard but not intended for you cannot lawfully be used in any way.
- Indecent or profane language is prohibited.

◇ Radio licenses

(1) SHIP STATION LICENSE

When your craft is equipped with a VHF FM transceiver, you must have a current radio station license before using the transceiver. It is unlawful to operate a ship station which is not licensed.

Inquire through your dealer or the appropriate government agency for a Ship-Radiotelephone license. This license includes the call sign which is your craft's identification for radio purposes.

(2) OPERATOR'S LICENSE

A restricted Radiotelephone Operator Permit is the license most often held by small vessel radio operators when a radio is not required for safety purposes.

The Restricted Radiotelephone Operator Permit must be posted near the transceiver or be kept with the operator. Only a licensed radio operator may operate a transceiver.

However, non-licensed individuals may talk over a transceiver if a licensed operator starts, supervises, ends the call and makes the necessary log entries.

A current copy of the applicable government rules and regulations is only required to be on hand for vessels in which a radio telephone is compulsory. However, even if you are not required to have these on hand it is your responsibility to be thoroughly acquainted with all pertinent rules and regulations.

■ Supplied accessories

The following accessories are supplied:	Qty.
• Handstrap	1
• Belt clip (MB-103)	1
• Ni-Cd battery pack (BP-225)	1
• Battery charger (BC-158)*	1
• Screws for the BC-158 (M3.5 × 20)*	2
• AC adapter (BC-147E)*	1
• Flexible antenna (FA-S59V)	1

*Not supplied with some version.

■ Attachments

◇ Flexible antenna

Connect the supplied flexible antenna to the antenna connector.

CAUTION: Transmitting without an antenna may damage the transceiver.

NEVER HOLD by the antenna when carrying the transceiver.

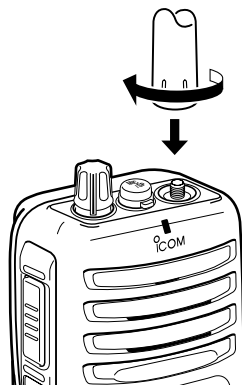

◇ Handstrap

Pass the handstrap through the loop on the top of the transceiver as illustrated at right. Facilitates carrying.

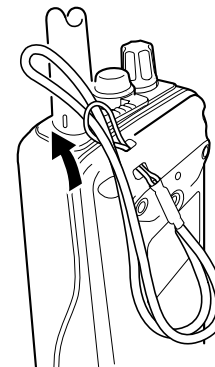

◇ Belt clip

Attach the belt clip to the transceiver as illustrated below.

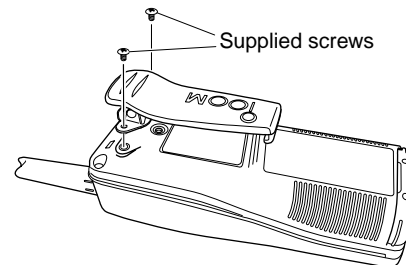

1
2

2 SUPPLIED ACCESSORIES AND ATTACHMENTS

◆ Battery pack

To remove the battery pack:

Turn the screw counterclockwise, then pull the battery pack in the direction of the arrow as shown below.

To attach the battery pack:

Insert the battery pack in the IC-M90E completely, then turn the screw clockwise.

NEVER remove or insert the battery pack when the transceiver is wet or soiled. This may result water or dust getting into the transceiver/battery pack and may result in the transceiver being damaged.

NOTE: When the lock screw does not easily (feels tight), check to ensure the battery pack is sufficiently inserted to the transceiver. **DO NOT** bang or cause high impact to the battery pack, as this may damage the battery pack/or the transceiver.

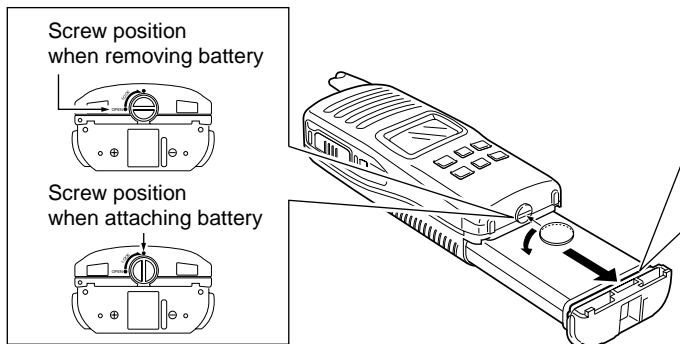

NOTE: When removing or attaching the battery pack, use a coin or flat-blade screwdriver to loosen or tighten the bottom screw.

CAUTION!: When attaching or removing a battery pack, make sure the rubber seal is set in the groove of the battery pack correctly. If the seal is not neatly in the groove it may be damaged when attaching the battery pack. If the seal is damaged, waterproofing is not guaranteed.

NOTE: When attaching a battery pack, make sure dust or else does not adhere to the rubber seal. If dust or else is on the seal when attaching a battery pack, the water resistant may be reduced. Make sure both the rubber seal (purple) is set to the groove correctly and dust or else does not adhere to it.

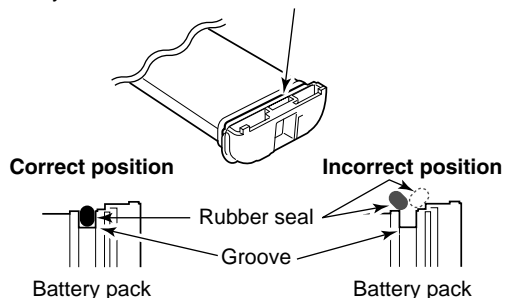

■ Front, top and side panels

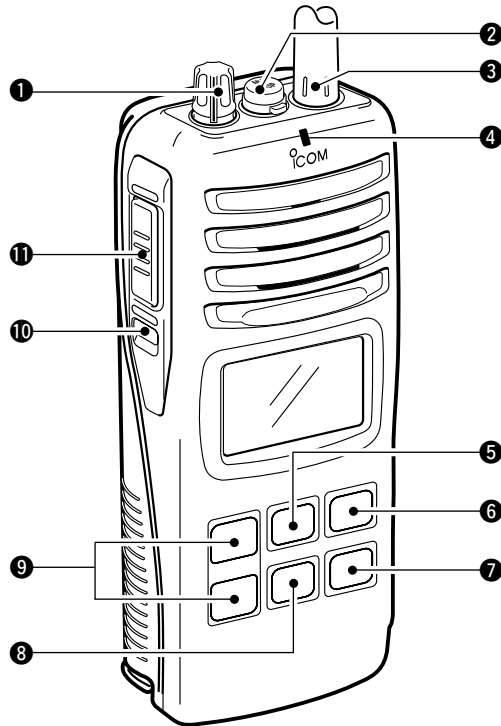

1 VOLUME CONTROL [VOL]

Turns power ON and adjusts the audio level.

2 MICROPHONE CONNECTOR [MIC/SP]

Connects the optional external microphone.

NOTE: Attach the [MIC/SP] cap when the optional speaker-microphone is not used.

3 ANTENNA CONNECTOR

Connects the supplied antenna.

4 TRANSMIT/RECEIVE INDICATOR

Lights green while receiving a signal or when the squelch is open; lights red while transmitting; lights orange while the VOX function is used.

5 DIAL/CHANNEL GROUP KEY [DIAL]

- Selects one of 3 regular channels in sequence when pushed for 1 sec. (pgs. 8, 15)
- U.S.A.*¹ (or ATIS*²), International and LAND (PMR) channels are available.

*¹U.K. version only.

*²German version only.

- Push to return to the condition before selecting the channel when the priority channel or the call channel is selected.

6 SCAN KEY [SCAN•DUAL]

- Starts and stops normal or priority scan when pushed. (pgs. 12, 13)
- Enters watch mode when pushed for 1 sec. (p. 14)

3 PANEL DESCRIPTION

7 TRANSMIT POWER/LOCK KEY [Hi/Lo]

- Selects high, middle or low power when pushed. (p. 9)
- Toggles the lock function ON/OFF when pushed for 1 sec. (p. 10)

8 CHANNEL 16 KEY [16•C]

- Selects Channel 16 when pushed. (p. 7)
- Selects call channel when pushed for 1 sec. (p. 7)
- Enters call channel write mode when the call channel is selected and this key is pushed for 3 sec. (p. 10)

9 CHANNEL UP/DOWN SWITCHES [▲]/[▼]

- Selects an operating channel. (pgs. 7–9)
- Selects the SET mode condition of the item. (p. 16)
- Selects the SET mode item when pushed with [SQL•MONI]. (p. 16)
- Checks tag channels or changes scanning direction during scan. (p. 13)

10 SQUELCH SWITCH [SQL•MONI]

- Push this switch, then adjust the squelch level with [▲]/[▼]. (p. 11)
- Manually opens the squelch for monitoring the channel while pushed and held. (p. 10)
- While pushing this switch, turn power ON to enter the SET mode. (p. 16)
- Selects the SET mode item. (p. 16)

11 PTT SWITCH [PTT]

Push and hold to transmit; release to receive.

■ Function display

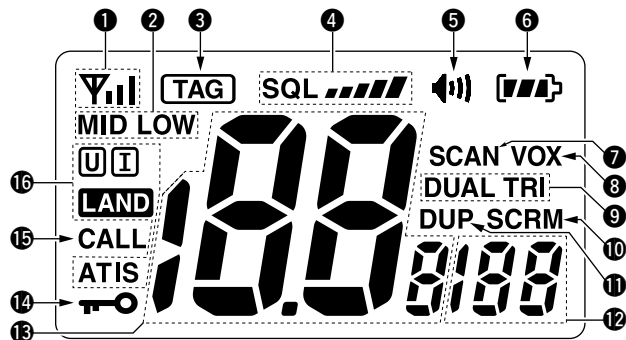

1 SIGNAL STRENGTH INDICATOR (pgs. 10, 20)

Shows the relative signal strength while receiving signals.

2 TRANSMIT POWER INDICATOR

- “LOW” appears when low power is selected.
- “MID” appears when middle power is selected.
- No indication appears when high power is selected.

3 TAG CHANNEL INDICATOR (p. 13)

Appears when tag channel is selected.

4 SQUELCH LEVEL INDICATOR (p. 11)

Shows the squelch level.

5 MONITOR INDICATOR (p. 10)
Appears when the monitor function is activated.

6 BATTERY INDICATOR
Indicates remaining battery power.

Indication				
Battery level	Full	Middle	Charging required	No battery

blinks when the battery is over charged.

blinks when the battery is exhaustion.

7 SCAN INDICATOR (p. 13)
“SCAN” blinks during scan.

8 VOX INDICATOR (p. 15)
“VOX” appears when the VOX function is used.

9 DUALWATCH/TRI-WATCH INDICATORS (p. 14)
“DUAL” blinks during dualwatch; “TRI” blinks during tri-watch.

10 SCRAMBLER INDICATOR
Appears when the optional voice scrambler is activated.
(pgs. 11, 20)

11 DUPLEX INDICATOR
Appears when a duplex channel is selected.

12 SUB CHANNEL READOUT

- Indicates Channel 16 during priority scan or dualwatch. (p. 14)
- Indicates the SET mode items while in the SET mode. (p. 16)

13 CHANNEL NUMBER READOUT

- Indicates the selected operating channel number.
- In SET mode, indicates the selected condition.

14 LOCK INDICATOR
Appears when the lock function is activated.

15 CALL CHANNEL INDICATOR
Appears when the call channel is selected.

16 CHANNEL GROUP INDICATOR
“” appears when International; “” appears when U.S.A. (U.K. version only); “” appears when LAND (PMR) channel group is selected. “ATIS” appears when the channel group in which ATIS function is activated (German version only).

■ Channel selection

IMPORTANT! Prior to using the transceiver for the first time, the battery pack must be fully charged for optimum life and operation. To avoid damage to the battery pack or charger, turn the power OFF while charging.

◇ Channel 16

Channel 16 (Distress channel) is used for establishing initial contact with another station and for emergency communications. Channel 16 is automatically monitored during both dualwatch and tri-watch. While standing by, you must monitor Channel 16.

- ① Push [16•C] to select Channel 16.
- ② Push [DIAL] to return to the condition before selecting Channel 16, or push [▲]/[▼] to select the operating channel.

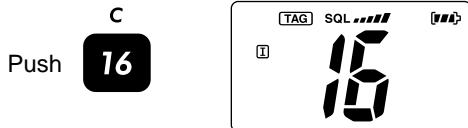

◇ Call channel

Each regular channel group has separate call channels. In addition, the call channel is monitored during tri-watch. The call channels can be re-programmed (p. 10) and may be used to store your most often used channel in each channel group for quick recall.

- ① Push [16•C] for 1 sec. to select the call channel.
 - “CALL” and the call channel number appear.
 - Call channel can be re-programmed. See the “Call channel programming” on p. 10 for details.
- ② Push [DIAL] to return to the condition before selecting the call channel, or push [▲]/[▼] to select the operating channel.

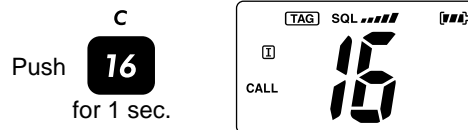

NOTE: Channel 16 is default setting.
(Depending on version)

◇ International, U.S.A.*1 and ATIS*2 channels

The IC-M90E has 57*3 International, 59 U.S.A.*1 and 57 ATIS*2 channels. You must select the proper channels for the operating area.

*3International channel numbers are depended on versions.

- ① Push [DIAL] to select the regular channel.
- ② Push [▲]/[▼] to select a channel.
 - “DUP” appears for duplex channels.
- ③ To change the channel group, push [DIAL] for 1 sec.
 - International, U.S.A*1 and ATIS*2 channels can be selected in sequence. Depending on the setting, LAND (PMR) channel can be selected. See the “LAND (PMR) CHANNEL OPERATION” on p. 15 for details.

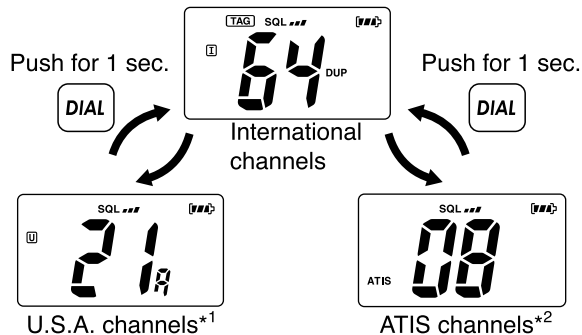

*1U.K. version only.

*2German version only.

4 BASIC OPERATION

■ Receiving and transmitting

CAUTION: Transmitting without an antenna may damage the transceiver.

- ① Rotate [VOL] clockwise to turn power ON.
- ② Set the volume and squelch level.
 - ➡ Push [SQL•MONI], and push [▼] to open the squelch.
 - ➡ Push [SQL•MONI] to stop “SQL” indicator blinking, then rotate [VOL] to set the volume level.
 - ➡ Push [SQL•MONI], and push [▲]/[▼] to set the squelch level.
- ③ Push [▲]/[▼] to select the desired channel.
 - When receiving a signal, the [TRANSMIT/RECEIVE] indicator lights green while audio is emitted from the speaker.
 - Further adjustment of [VOL] may be necessary at this point.
- ④ Push [Hi/Lo•] to select the output power if necessary.
 - “LOW” appears when low power is selected; “MID” appears when middle power is selected; no indication when high power is selected.
 - Choose low power to conserve battery power, choose high power for longer distance communications.
- ⑤ Push and hold [PTT] to transmit, then speak into the microphone.
 - The [TRANSMIT/RECEIVE] indicator lights red while transmitting.
 - Channel 70 cannot be used for transmission.
- ⑥ Release [PTT] to receive.

IMPORTANT: To maximize the readability of your transmitted signal, pause a few sec. after pushing [PTT], hold the microphone 5 to 10 cm from your mouth and speak into the microphone at a normal voice level.

NOTE: The transceiver has a power save function to conserve the battery power. The power save function activates automatically when no signal is received for 5 sec.

To prevent accidental prolonged transmission, etc., the IC-M90E has a time-out-timer function. This timer cuts a transmission OFF after 5 min. of continuous transmission.

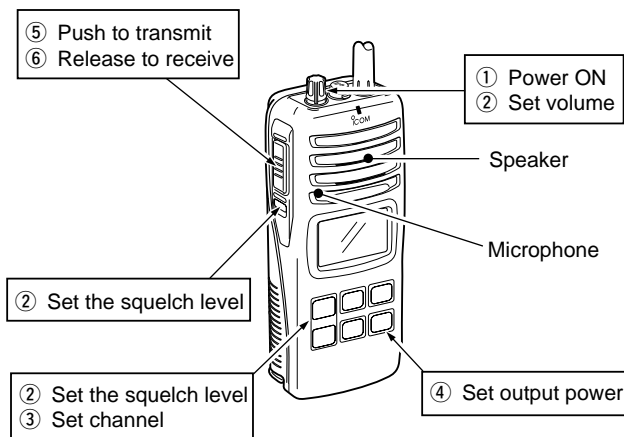

Call channel programming

The call channel key is used to select the default channel, however, you can program your most often-used channel in each channel group for quick recall.

- 1 Push [DIAL] for 1 sec. several times to select the desired channel group (INT, USA*1, ATIS*2) to be programmed.



*1U.K version only, *2German version only

- 2 Push [16•C] for 1 sec. to select the call channel.
 - “CALL” and the call channel number appear.



- 3 Push [16•C] again for 3 sec. (until a long beep changes to 2 short beeps) to enter call channel programming condition.

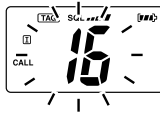

- Call channel number to be programmed flashes.

- 4 Push [▲]/[▼] to select the desired channel.



- 5 Push [16•C] to program the displayed channel as the call channel.
 - The call channel number stop flashing.

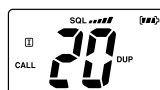

Lock function

This function electronically locks all keys (except for [PTT], [SQL•MONI] and [Hi/Lo•]) to prevent accidental channel changes and function access.

- Push [Hi/Lo•] for 1 sec. to turn the lock function ON and OFF.

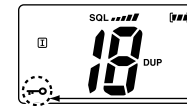

Appears while the lock function is used.

Signal strength indicator

The received signal strength level is indicated by number of bars as below.

This indicator can be hidden by using the SET mode (p. 20) if desired.

Indication	▾▾▾▾	▾▾▾	▾▾	▾
Signal strength	Strong	Middle	Weak	No signal or very weak

Monitor function

The monitor function releases the noise squelch mute manually. This function is convenient when receiving a weak signal, or when adjusting the volume level, etc.

- Push [SQL•MONI] for 1 sec. and keep holding to activate the monitor function.
 - “” appears and audio is emitted.

4 BASIC OPERATION

■ Adjusting the squelch level

To adjust the IC-M90E's squelch level, use the [▲]/[▼] keys as described below. In order to receive signals properly, as well as for the scan to function effectively, the squelch must be adjusted to the proper level.

- ① Push [SQL•MONI], then adjust the squelch level with [▲]/[▼].
 - "SQL" indicator starts blinking.
 - There are 11 squelch levels to choose from: OP is completely open; 10 is tight squelch; 1 is loose squelch level.
- ② Push [SQL•MONI] again to return to normal condition.
 - When no switch is pushed for 5 sec., the transceiver returns to normal condition.

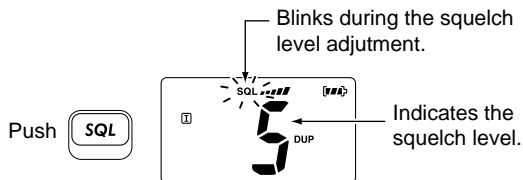

■ Backlighting function

This function is convenient for nighttime operation. The backlighting brightness can be adjusted in the SET mode. (p. 18)

- ➡ Push any key except [PTT] to turn the backlighting ON.
 - The backlighting is automatically turned OFF after 5 sec. of inactivity.

■ Voice scrambler operation

◇ Activating the scrambler

The voice scrambler provides private communications. In order to receive or send scrambled transmissions, you must activate the scrambler function first.

- ① Select an operating channel except Channel 16 or 70.
- ② While pushing and holding [SQL•MONI], push [SCAN•DUAL].
 - "SCRM" appears.
- ③ To turn the scrambler function OFF, repeat step ②.
 - "SCRM" disappears.

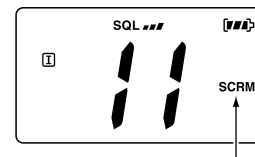

Appears when the voice scrambler function is in use.

◇ Programming scramble codes

32 scrambler codes (1 to 32) are available for voice scrambler operation. Set the code in the SET mode. In order to understand each other, all transceivers in your group must have the same scrambler code. See p. 20 for "Scrambler code" setting details.

■ Scan types

Scanning is an efficient way to quickly locate signals over a wide frequency range. The transceiver has a priority scan setting and normal scan setting.

In addition, the "Auto scan" function is available for scanning. This function can be activated simultaneously, depending on the settings on the SET mode. (p. 17)

Set the tag channels (scanned channel) before scanning. Clear those tag channels which are not needed or inconveniently stop scanning, such as digital communications.

/// Choose priority or normal scan on the SET mode. (p. 17)

4

5

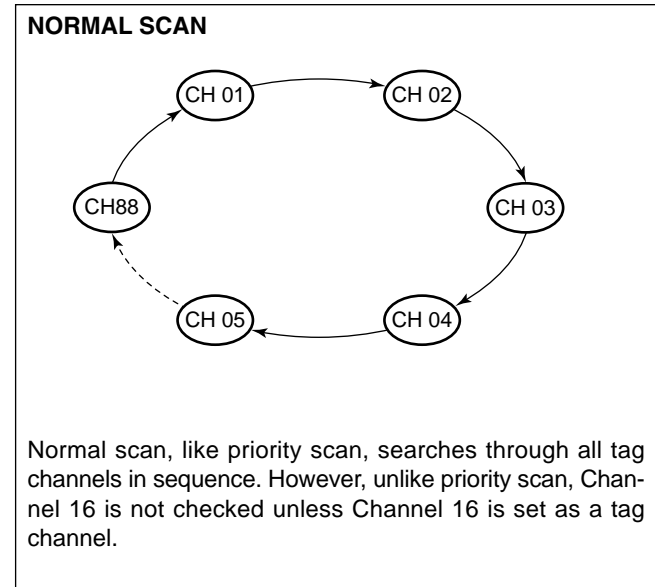
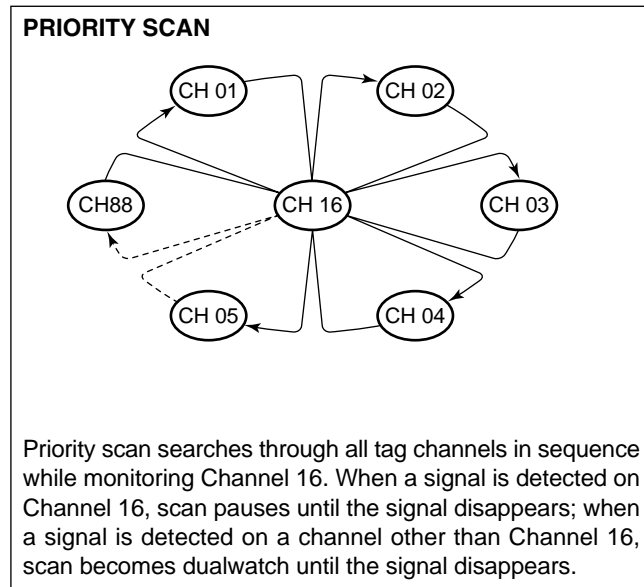

5 SCAN OPERATION

■ Setting tag channels

For more efficient scanning, add desired channels as tag channels or clear the tag for unwanted channels.

Non-tag channels will be skipped during scanning. Tag channels can be assigned to each channel group (INT, USA*¹, ATIS*²) independently.

- ① Select the desired channel group (INT, USA*¹, ATIS*²) by pushing [DIAL] for 1 sec., if desired.
*¹U.K. version only, *²German version only
- ② Select the desired channel to set as a tag channel.
- ③ Push both [▲] and [▼] for 1 sec. to set the displayed channel as a tag channel.
 - “[TAG]” appears in the function display.
- ④ To cancel the tag channel setting, push both [▲] and [▼] for 1 sec.
 - “[TAG]” disappears.

✓ Clearing all tag channels in the selected channel group

While pushing and holding both [▲] and [▼], turn power ON to clear all tag channels in the channel group.

■ Starting a scan

Set the priority scan function, scan resume timer and auto scan function in advance, using the SET mode. (p. 17)

- ① Select the desired channel group (INT, USA*¹, ATIS*²) by pushing [DIAL] for 1 sec., if desired.
*¹U.K. version only, *²German version only
- ② Push [SCAN•DUAL] to start priority or normal scan.
 - “SCAN” blinks in the function display.
 - “16” appears on the sub channel readout during priority scan.
 - When a signal is received, scan pauses until the signal disappears or resumes after pausing 5 sec. according to scan resume timer setting. (Channel 16 is still monitored during priority scan.)
 - Push [▲]/[▼] to check the scanning tag channels, change the scanning direction or resume the scan manually.
- ③ To stop the scan, push [SCAN•DUAL].
 - “SCAN” disappears.
 - Pushing [PTT], [16•C] or [DIAL] also stops the scan.

[Example]: Starting a normal scan.

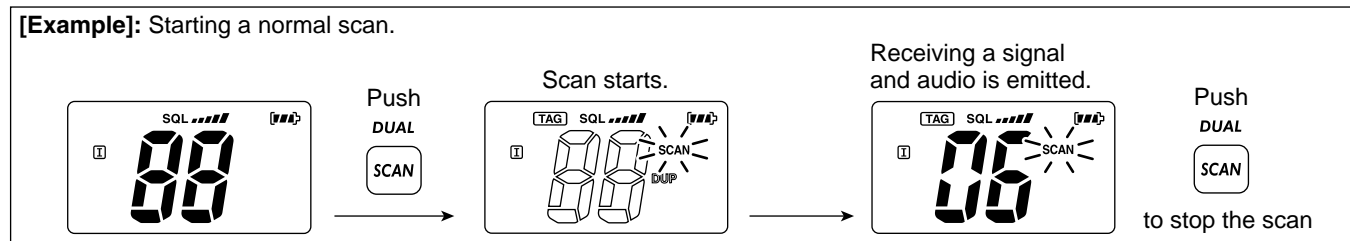

■ Description

Dualwatch monitors Channel 16 while you are receiving another channel; tri-watch monitors Channel 16 and the call channel while receiving another channel.

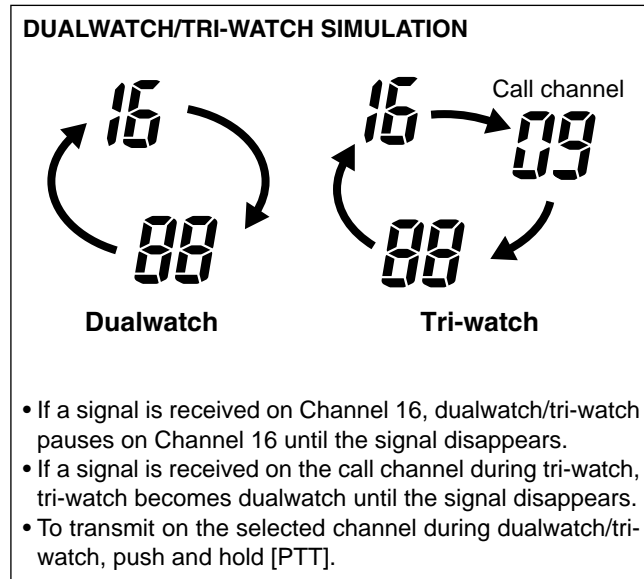

■ Operation

- ① Select the desired operating channel.
- ② Push [SCAN•DUAL] for 1 sec. to start dualwatch or tri-watch (depending on the SET mode setting).
 - “DUAL” blinks during dualwatch; “TRI” blinks during tri-watch.
 - A beep tone sounds when a signal is received on Channel 16.
 - Tri-watch becomes dualwatch when receiving a signal on the call channel.
- ③ To cancel dualwatch/tri-watch, push [SCAN•DUAL] again.

[Example]: Operating tri-watch on INT channel 07.

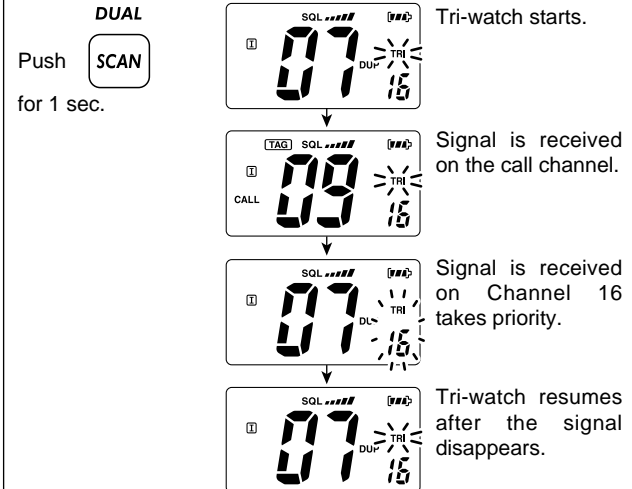

■ LAND (PMR) channel group

A max. of 100 PMR channels (allocated 146.000 to 174.000 MHz) can be programmed into the LAND channel group for simple communication with PMR transceivers in the VHF band.

Moreover, any of the marine channels in the USA*¹, INT and ATIS*² channel groups can be programmed.

The default setting of the LAND channel group is the same as that of the INT channel group. Ask your local Icom dealer for the LAND channel group setting and PMR frequency programming details.

*¹U.K. version only, *²German version only

- ① Push [DIAL] to select a regular channel.
- ② To change the channel group, push [DIAL] for 1 sec. several times.
 - “LAND” appears when LAND channel group is selected.
- ③ Push [▲]/[▼] to select a channel.
 - “DUP” appears for duplex channels.

Push for 1 sec.
several times.

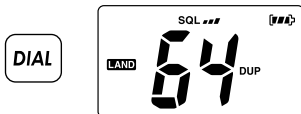

/// **NOTE:** The default settings (e.g. call channel programming) of the LAND channel group are same as the International and U.S.A. channels. Refer to the appropriate pages for details.

■ CTCSS and DTCS display

When DTCS or CTCSS is set in the selected channel, the sub channel readout displays as below.

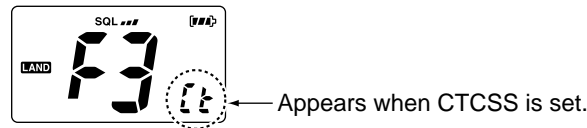
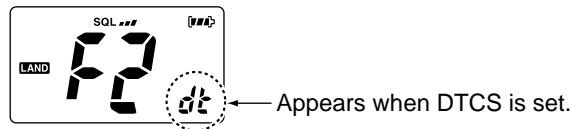

■ VOX function

The VOX function (voice operated transmission) starts transmission without pushing [PTT] when you speak into the microphone; then automatically returns to receive when you stop speaking (hands-free operation becomes possible).

/// **NOTE:** An optional headset and headset adapter is required for the VOX operation.

- ➔ Push and hold [SQL•MONI], then push [Hi/Lo•] to turn the VOX function ON/OFF while connecting the optional headset and headset adapter to [MIC/SP] connector.
 - “VOX” appears on the LCD while the VOX function turns ON.
 - The “VOX gain” and “VOX delay” can be set in the SET mode. (p. 21)

■ SET mode programming

SET mode is used to change the condition of 16 transceiver functions: beep tone function, priority scan function, scan resume timer, auto scan function, dual/tri-watch function, monitor switch action, backlighting function, LCD contrast selection, auto power save function, self check function, battery voltage indicator, signal strength indicator, squelch sensitivity, scrambler code, VOX gain and VOX delay.

◇ SET mode operation

- ① Turn power OFF.
- ② While pushing [SQL•MONI], turn power ON to enter the SET mode.
 - "bp" (Beep tone function setting) appears.
- ③ Push [SQL•MONI] or [SQL•MONI] and [▲]/[▼] to select the desired item, if necessary.
- ④ Push [▲]/[▼] to select the desired condition of the item.
- ⑤ Push [16•C] to exit the SET mode.

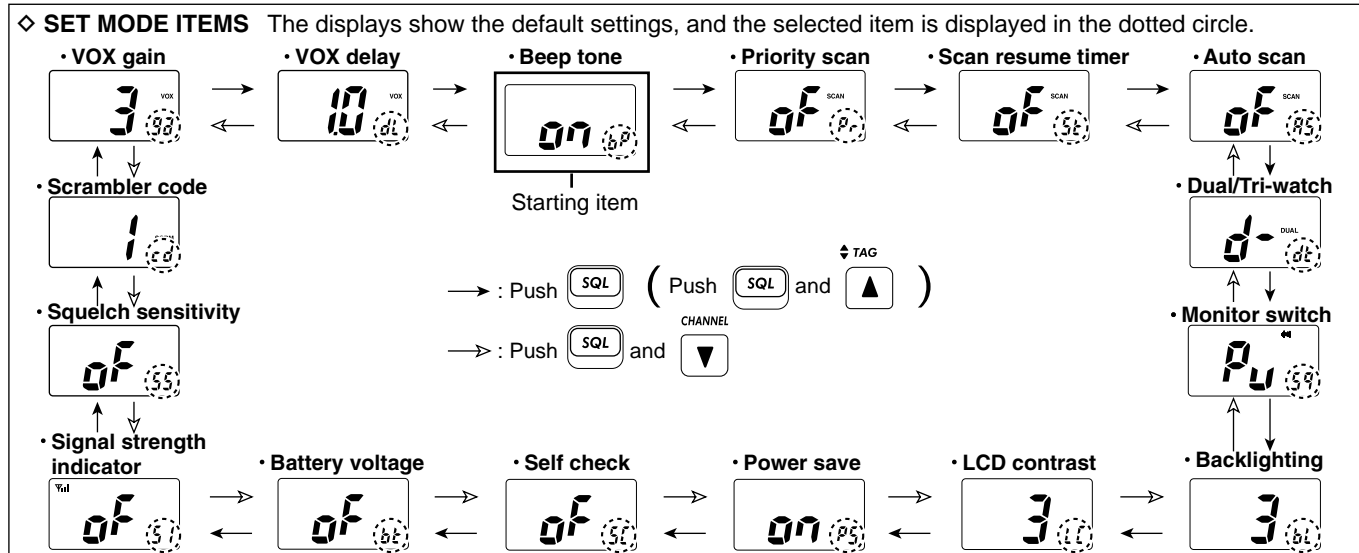

■ SET mode items

◇ Beep tone function “bP”

You can select silent operation by turning the beep tones OFF, or you can have 2 types of confirmation beeps sound at the push of a key. When “ON” is selected, a fixed beep (Pi) sounds, and when “US” is selected, the preset beeps (e.g. do, re, mi) sound.

- Beep tone synchronizes with the volume level.
- The beeps sound during call channel programming even if this function is turned OFF.

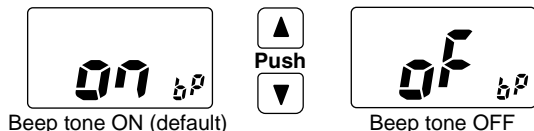

◇ Priority scan function “Pr”

The transceiver has 2 scan types—normal (OFF) and priority (ON) scans. Normal scan searches all tag channels in the selected channel group. Priority scan searches all tag channels in sequence while monitoring Channel 16.

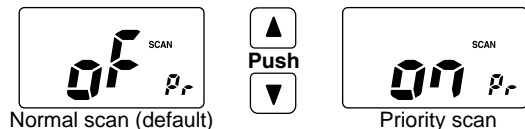

◇ Scan resume timer “St”

The scan resume timer can be set as a pause (OFF) or timer scan (ON). When OFF is selected, the scan pauses until a received signal disappears. When ON is selected, the scan pauses for 5 sec. after receiving a signal and then resumes even if the signal has been received.

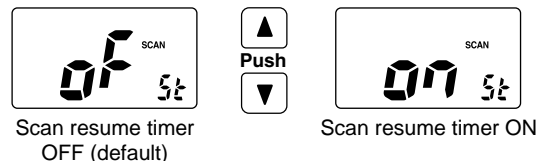

◇ Auto scan function “AS”

The Auto scan function starts the desired scan automatically when no signal is received, and no operation is performed for 30 sec.

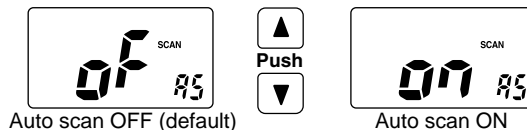

◇ **Dual/Tri-watch function “dt”**

This item selects dual or tri-watch as desired. See p. 14 for details.

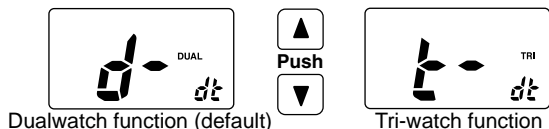

◇ **Monitor switch action “Sq”**

The monitor switch action cuts off the squelch function temporarily. This switch action contains PUSH (Pu) or HOLD (Ho) settings as shown below.

- PU (PUSH): After pushing [SQL•MONI] for 1 sec., the squelch opens and emits audio. The squelch is held open while continuously pushing and holding [SQL•MONI]. (default)
- HO (HOLD): After pushing [SQL•MONI] for 1 sec., the squelch opens and emits audio even [SQL•MONI] is released. To close the squelch, push any switch.

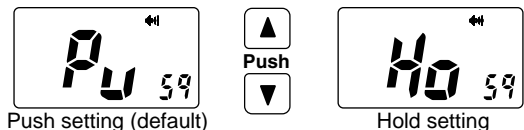

◇ **Backlighting function “bL”**

This function is convenient for nighttime operation. The backlighting brightness can be adjusted from OFF, 1 (dark)–3 (bright); 3 (default). Select 1–3 to turn this function ON.

- The automatic backlighting turns the backlighting ON when any key except for [PTT] is pushed.
- The backlighting is automatically turned OFF after 5 sec. of inactivity.

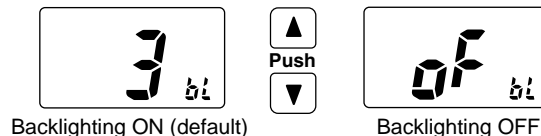

◇ **LCD contrast selection “LC”**

The contrast of the LCD can be adjusted from 4 levels.

- 1 (bright)–4 (dark); 3 (default)

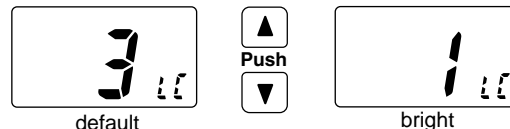

8 SET MODE

◇ Auto power save function “PS”

The auto power save function reduces current drain by deactivating the receiver circuit for preset intervals.

- ON : The power save function is turned ON. The power save function will activate when no signal is received, and no operation is performed for 5 sec.
- OFF: The power save function is turned OFF.

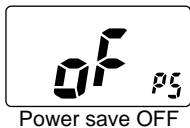
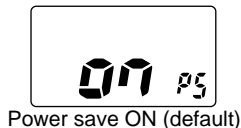

◇ Self check function “SC”

The self check function checks the transceiver conditions by itself, and informs you in case a problem is found. Self check automatically and quickly runs through its diagnostic steps each time the radio is turned ON. Afterwards, the radio switches to normal operation mode.

- Temperature : Outside of -35°C to $+73^{\circ}\text{C}$ (approx.)
- Connected battery voltage

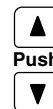
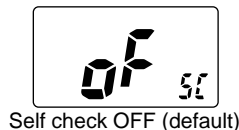

When error messages as shown below are displayed, see troubleshooting for advice. (p. 28)



Temperature error



Battery voltage error

◇ **Battery voltage indicator “bt”**

This function controls display or non-display settings of the connected battery pack’s voltage when the power is ON.

- The voltage of the connected battery pack is displayed for 2 sec. after power is turned ON.



Battery voltage indication OFF (default)

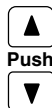

Battery voltage indication ON

◇ **Signal strength indicator “SI”**

The signal strength indicator displays received signal strength as “S-meter.” This function is convenient to check the signal strength visually.

- The strength is displayed at 4 steps.
- The antenna mark and 3 bars appear when receiving strong signals.
- The antenna mark only appears when receiving no signal.



Signal strength indication OFF (default)



Signal strength indication ON

◇ **Squelch sensitivity function “SS”**

When this function is turned ON, blocking against noise is improved. Therefore the squelch is not easily affected by noise.



Squelch sensitivity OFF (default)



Squelch sensitivity ON

◇ **Scrambler code “cd”**

There are 32 codes (1 to 32) available for programming. In order to understand each other, all transceivers in your group must share the same scrambler code.

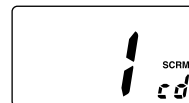

Scrambler code 1 (default)

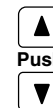

Scrambler code 32

8 SET MODE

◇ VOX gain “ga”

Adjusts the VOX gain (from 1 to 6) to level when speaking with the optional headset.

- Setting the VOX gain to 1 increases the sensitivity.
- Setting the VOX gain to 6 reduces the sensitivity.



VOX gain 3 (default)



VOX gain 6

◇ VOX delay “dL”

Sets the VOX delay timer (0.5 to 3.0 sec. in 0.5 sec. steps) that keeps on transmitting after you stop speaking.

- Setting the VOX delay to 0.5 (0.5 sec.) is a short VOX delay.
- Setting the VOX delay to 3.0 (3.0 sec.) is a long VOX delay.



VOX delay 1.0 (default)



VOX delay 3.0

SET MODE LIST

Function	Indication	Switch
Beep tone function	“bP”	OFF/ON*/US
Priority scan function	“Pr”	OFF*/ON
Scan resume timer	“St”	OFF*/ON
Auto scan function	“AS”	OFF*/ON
Dual/Tri-watch function	“dt”	Dual*/Tri
Monitor switch action	“Sq”	Push*//Hold
Backlighting function	“bL”	OFF/1/2/3*
LCD contrast selection	“LC”	1/2/3*/4
Auto power save function	“PS”	OFF/ON*
Self check function	“SC”	OFF*/ON
Battery voltage indicator	“bt”	OFF*/ON
Signal strength indicator	“SI”	OFF*/ON
Squelch sensitivity	“SS”	OFF*/ON
Scrambler code	“cd”	1*/2/· · /31/32
VOX gain	“ga”	1/2/3*/4/5/6
VOX delay	“dL”	0.5/1.0*/1.5/2.0/2.5/3.0

*default setting

■ Battery charging

Prior to using the transceiver for the first time, the battery pack must be fully charged for optimum life and operation.

CAUTION: To avoid damage to the transceiver, turn the power OFF while charging.

- Recommended temperature range for charging: +10°C to +40°C
- Use the specified chargers (BC-158, BC-119N and BC-121N). **NEVER** use another manufacture's charger.
- Use the supplied AC adapter for the BC-158. **NEVER** use another manufacture's adapters.

Turn the transceiver OFF when charging an attached battery pack. Otherwise, the battery pack may not become full-charging or may not charge properly.

■ Battery cautions

CAUTION! NEVER insert battery pack/transceiver (with the battery pack attached) with wet or soiled into the charger. This may result in corrosion of the charger terminals or damage to the charger. The charger is not waterproof and water can easily get into it.

NEVER incinerate used battery packs. Internal battery gas may cause an explosion.

NEVER immerse battery pack in water. If the battery pack becomes wet, be sure to wipe it dry immediately (particularly the battery terminals BEFORE attaching it to the transceiver).

NEVER short terminals of the battery pack. Also, current may flow into nearby metal objects, such as a necklace, etc. Those may cause burn, electric shock or fire. Therefore, be careful when carrying in a pocket, backpack or handbag, and when placing the radio near metal objects.

If your battery pack seems to have no capacity even after being charged, completely discharge it by leaving the power ON overnight. Then, fully charge the battery pack again. If the battery still do not retain a charge (or very little), new battery pack must be replaced.

9 BATTERY CHARGING

◇ Charging connections

- ① Attach the BC-158 to a flat surface, such as a desk or cabin, etc., if desired.
- ② Connect the AC adapter as shown below.
- ③ Insert the battery pack with/without the transceiver into the charger.
 - The charge indicator lights green.
- ④ Charge the battery pack approx. 12 hours, depending on the remaining power condition.

DO NOT charge BP-225 more than 18 hours. Otherwise, BP-225 will be damaged. BP-225 must be charged for 12–18 hours only.

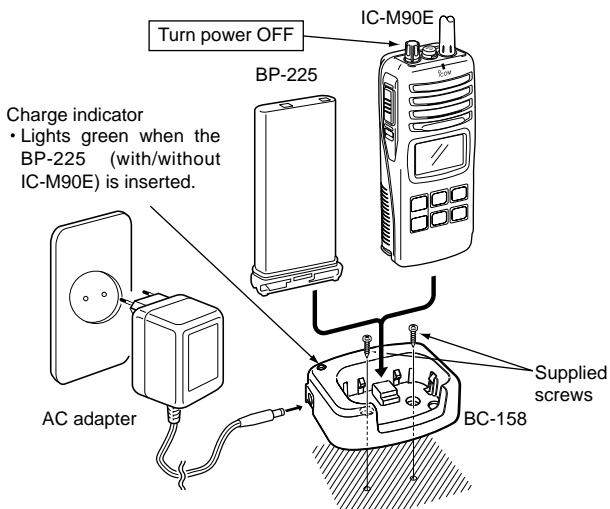

■ Optional battery case

When using a battery case attached to the transceiver, install 6 × AA(LR6) size Alkaline batteries as illustrated below.

- ① Remove the battery case from the transceiver.
- ② Install 6 × AA(LR6) size Alkaline batteries.
 - Be sure to observe the correct polarity.

CAUTION:

- When installing batteries, make sure they are all the same brand, type and capacity. Also, do not mix new and old batteries together.
- Keep battery contacts clean. It's a good idea to clean battery terminals once a week.

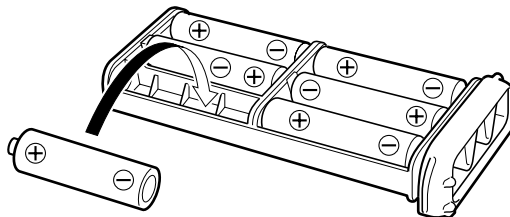

■ Optional battery chargers

◇ AD-109 installation

- ① Connect the 10-pins connector of the charger to the AD-109 desktop charger adapter's plug.

/// **NOTE:** The 3-pins connector is not used.

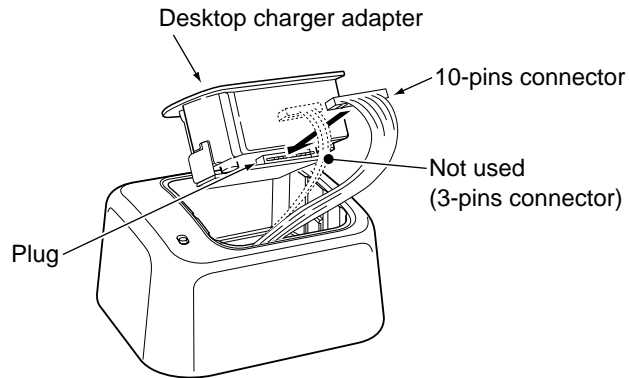

- ② Install the adapter into the charger in the direction of the arrow, then screw supplied 2 screws to fix the charger adapter with the charger.

/// **NOTE: BE CAREFUL** not to catch the unused 3-pins plug between the charger and the charger adapter.

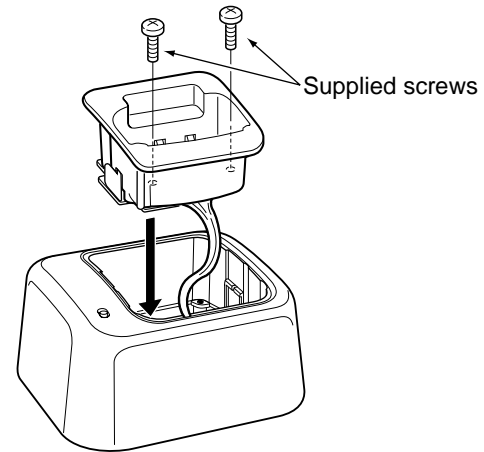

9 BATTERY CHARGING

◇ Rapid charging with the BC-119N+AD-109

The optional BC-119N provides rapid charging of battery packs. The following are additionally required.

- AD-109 charger adapter
- An AC adapter (BC-145E)* or the DC power cable (OPC-515L/CP-17L).

*Not supplied with some version.

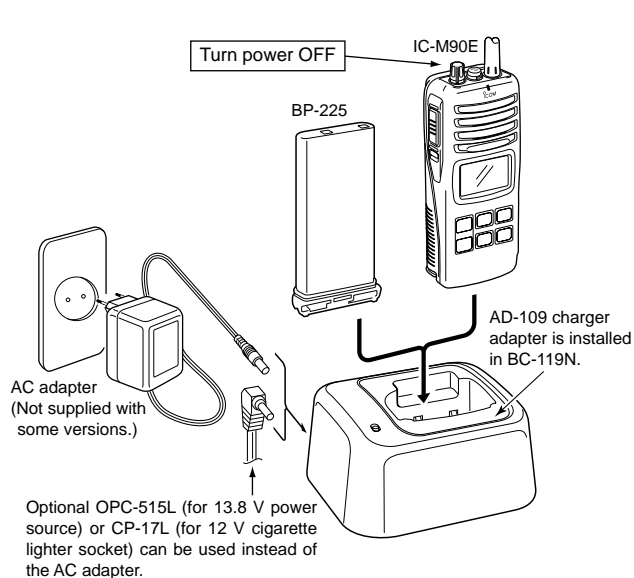

◇ Rapid charging with the BC-121N+AD-109

The optional BC-121N allows up to 6 battery packs to be charged simultaneously. The following are additionally required.

- Six AD-109 charger adapters
- An AC adapter (BC-124) or the DC power cable (OPC-656)

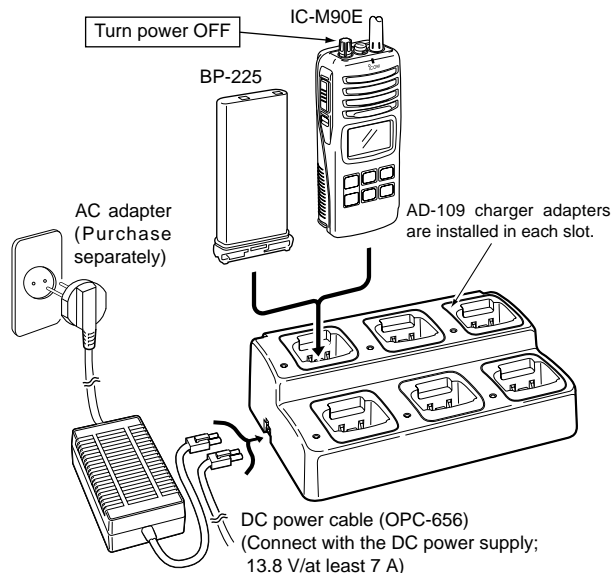

■ MB-86 contents

	Qty.
Belt clip	1
Base clip	1
Supplied screws	2

■ Attachment

- ① Screw the base clip to the back of the transceiver using the two screws (supplied), as shown below.

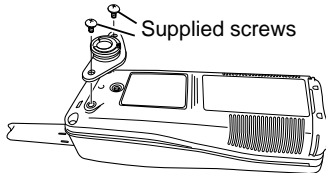

- ② Clip the belt clip over your belt and insert the transceiver.

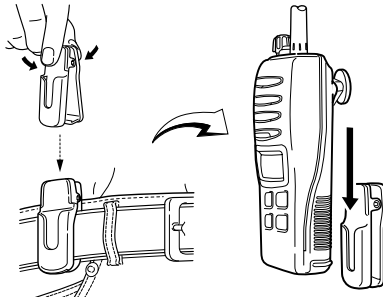

- ③ Once the transceiver is locked in place, it swivels as illustrated below.

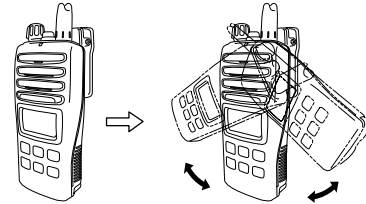

■ Detachment

- Turn the transceiver upside down in the direction of the arrow and pull out from the belt clip.

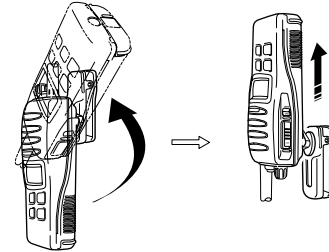

⚠ CAUTION!
HOLD THE TRANSCEIVER TIGHTLY, WHEN HANGING OR DETACHING THE TRANSCEIVER FROM THE BELT CLIP.

Otherwise the transceiver may not be attached to the belt clip or swivelled properly if the transceiver is accidentally dropped and the base clip is scratched or damaged.

■ HM-125 descriptions

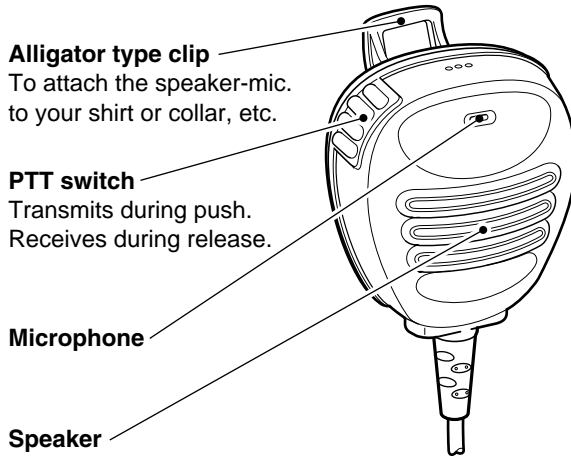

NEVER immerse the connector in water without connecting with the transceiver. If the connector becomes wet, be sure to dry **BEFORE** attaching it to the transceiver.

NOTE: The microphone is located at the top of the speaker-microphone, as shown in the diagram above. To maximize the readability of your transmitted signal (voice), hold the microphone approx. 2.5 cm from your mouth, and speak in a normal voice level.

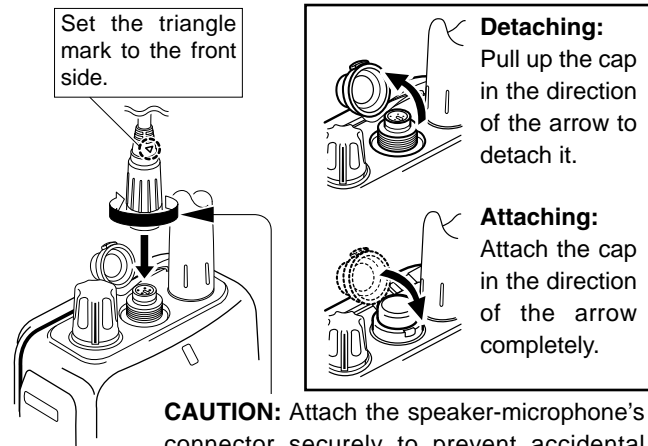

■ Attachment

Insert the speaker-mic connector onto the [MIC/SP] connector and carefully screw it tight, as shown in the diagram below. Be careful not to cross thread the connection.



CAUTION: Attach the speaker-microphone's connector securely to prevent accidental dropping, or water intrusion in the connector.

IMPORTANT: KEEP the transceiver's [MIC/SP] connector cap attached when the speaker-microphone is not in use. Water will not get into the transceiver even if the cover is not attached, however, the terminals (pins) will become rusty, or the transceiver will function abnormally if the connector has become wet.

PROBLEM	POSSIBLE CAUSE	SOLUTION	REF.
The transceiver does not turn ON.	<ul style="list-style-type: none"> The battery is exhausted. Bad connection to the battery pack. 	<ul style="list-style-type: none"> Recharge the battery pack. Check the connection to the transceiver. 	pgs. 23, 25 p. 3
No sound from the speaker.	<ul style="list-style-type: none"> Squelch level is too deep. Volume level is too low. Speaker has been exposed to water. Water has entered to [MIC/SP] connector. 	<ul style="list-style-type: none"> Set squelch to the threshold point. Rotate [VOL] to set a suitable level. Drain water from the speaker. Dry [MIC/SP] connector. 	p. 11 p. 9 — —
Transmitting is impossible, or high power can not be selected.	<ul style="list-style-type: none"> Lock function is activated. The battery is exhausted. The battery is over charged. 	<ul style="list-style-type: none"> Push [Hi/Lo•] for 1 sec. to cancel the function. Recharge the battery pack. Verify the battery voltage is correct. 	p. 10 pgs. 23, 25 —
The displayed channel cannot be changed.	<ul style="list-style-type: none"> Lock function is activated. 	<ul style="list-style-type: none"> Push [Hi/Lo•] for 1 sec. to cancel the function. 	p. 10
Scan does not start.	<ul style="list-style-type: none"> “TAG” channels are not programmed. 	<ul style="list-style-type: none"> Set the desired channels as “TAG” channels. 	p. 13
No beeps.	<ul style="list-style-type: none"> Beep tones are turned OFF. 	<ul style="list-style-type: none"> Set the beep tones to ON (Fix Beep/User Beep) in the SET mode. 	p. 17
Self check error. (Temperature)	<ul style="list-style-type: none"> The temperature is outside of -35°C to $+73^{\circ}\text{C}$ (approx) 	<ul style="list-style-type: none"> Leave the transceiver at room temperature for a while. Turn the power ON to check if the internal temperature has returned to normal. 	—
Self check error. (Battery voltage)	<ul style="list-style-type: none"> The connected battery pack’s voltage is more than 11 V. 	<ul style="list-style-type: none"> Verify the battery voltage is correct. 	—
Transmitting continuously while not speaking when using VOX function.	<ul style="list-style-type: none"> Ambient noise is too loud. 	<ul style="list-style-type: none"> Remove the headset cable. Set the VOX gain to dulling. 	— p. 21

13 VHF MARINE CHANNEL LIST

• International channels

CH	Frequency (MHz)		CH	Frequency (MHz)		CH	Frequency (MHz)		CH	Frequency (MHz)		CH	Frequency (MHz)		CH	Frequency (MHz)	
	Transmit	Receive		Transmit	Receive		Transmit	Receive		Transmit	Receive		Transmit	Receive		Transmit	Receive
01	156.050	160.650	11	156.550	156.550	21	157.050	161.650	62	156.125	160.725	72	156.625	156.625	82	157.125	161.725
02	156.100	160.700	12	156.600	156.600	22	157.100	161.700	63	156.175	160.775	73	156.675	156.675	83	157.175	161.775
03	156.150	160.750	13	156.650	156.650	23	157.150	161.750	64	156.225	160.825	74	156.725	156.725	84	157.225	161.825
04	156.200	160.800	14	156.700	156.700	24	157.200	161.800	65	156.275	160.875	75	156.775	156.775	85	157.275	161.875
05	156.250	160.850	15	156.750	156.750	25	157.250	161.850	66	156.325	160.925	76	156.825	156.825	86	157.325	161.925
06	156.300	156.300	16	156.800	156.800	26	157.300	161.900	67	156.375	156.375	77	156.875	156.875	87	157.375	157.375
07	156.350	160.950	17	156.850	156.850	27	157.350	161.950	68	156.425	156.425	78	156.925	161.525	88	157.425	157.425
08	156.400	156.400	18	156.900	161.500	28	157.400	162.000	69	156.475	156.475	79	156.975	161.575			
09	156.450	156.450	19	156.950	161.550	60	156.025	160.625	70	Rx only	156.525	80	157.025	161.625			
10	156.500	156.500	20	157.000	161.600	61	156.075	160.675	71	156.575	156.575	81	157.075	161.675			

• USA channels (for U.K. version only)

CH	Frequency (MHz)		CH	Frequency (MHz)		CH	Frequency (MHz)		CH	Frequency (MHz)		CH	Frequency (MHz)		CH	Frequency (MHz)	
	Transmit	Receive		Transmit	Receive		Transmit	Receive		Transmit	Receive		Transmit	Receive		Transmit	Receive
01A	156.050	156.050	12	156.600	156.600	22A	157.100	157.100	64A	156.225	156.225	77	156.875	156.875	86	157.325	161.925
--	---	---	13	156.650	156.650	23A	157.150	157.150	65A	156.275	156.275	78A	156.925	156.925	86A	157.325	157.325
03A	156.150	156.150	14	156.700	156.700	24	157.200	161.800	66A	156.325	156.325	79A	156.975	156.975	87	157.375	161.975
--	---	---	15	156.750	156.750	25	157.250	161.850	67	156.375	156.375	80A	157.025	157.025	87A	157.375	157.375
05A	156.250	156.250	16	156.800	156.800	26	157.300	161.900	68	156.425	156.425	81A	157.075	157.075	88	157.425	162.025
06	156.300	156.300	17	156.850	156.850	27	157.350	161.950	69	156.475	156.475	82A	157.125	157.125	88A	157.425	157.425
07A	156.350	156.350	18A	156.900	156.900	28	157.400	162.000	70	Rx only	156.525	83A	157.175	157.175	P4*	161.425	161.425
08	156.400	156.400	19A	156.950	156.950	37A*	157.850	157.850	71	156.575	156.575	84	157.225	161.825			
09	156.450	156.450	20	157.000	161.600	61A	156.075	156.075	72	156.625	156.625	84A	157.225	157.225			
10	156.500	156.500	20A	157.000	157.000	--	---	---	73	156.675	156.675	85	157.275	161.875			
11	156.550	156.550	21A	157.050	157.050	63A	156.175	156.175	74	156.725	156.725	85A	157.275	157.275			

*UK marine channels: M1=37A (157.850 MHz), M2=P4 (161.425 MHz) for U.K. version only.

GENERAL

- Frequency coverage
 - [Marine] TX : 156.000–161.450 MHz
 - RX : 156.000–163.425 MHz
 - [PMR] TX/RX : 146.000–174.000 MHz
- Mode
 - [Marine] : 16K0G3E (Wide)
 - [PMR] : 16K0F3E (Wide)* / 8K50F3E (Narrow)
 - *Germany version is 14K0F3E.
- Number of programmable ch. : 100 channels
- Power supply requirement : Battery packs (BP-223, BP-224 or BP-225 only)
- Current drain (approx.)
 - (at 7.2 V DC)
 - TX High (5 W) 1.6 A
 - TX Mid. (3 W) 1.2 A
 - TX Low (1 W) 0.7 A
 - TX Low (0.5 W) 0.6 A
 - RX Max audio 200 mA
- Frequency stability : ±1.5 kHz (–25°C to +55°C)
- Operating temperature range
 - [Marine] : –15°C to +55°C
 - [PMR] : –25°C to +55°C
- Antenna impedance : 50 Ω
- Dimensions : 65(W) × 145(H) × 44(D) mm
- (Projections not included)
- Weight (with BP-225) : Approx. 410 g

TRANSMITTER

- Output power (at 7.2 V DC) :
 - 5 W (Hi), 3 W (Middle) and 1 W (Low)
 - 1 W (Hi), 0.5 W (Low) for Germany version marine operation.
- Modulation system : Variable reactance frequency modulation
- Microphone impedance : 2 kΩ
- Max. frequency deviation
 - [Marine] : ±5 kHz (Wide)
 - [PMR] : ±5 kHz (Wide)* / ±2.5 kHz (Narrow)
 - *Germany ver. is ±4 kHz.

- Adjacent channel power
 - [Marine] : 70 dB
 - [PMR] : 70 dB (Wide), 60 dB (Narrow)
- Spurious emissions : 0.25 μW (less than 2 GHz)
- 1.0 μW (more than 2 GHz)
- Audio harmonics distortion : 10 % at 60 % deviation
- Residual modulation
 - [Marine] : 40 dB
 - [PMR] : 40 dB (Wide), 34 dB (Narrow)
- Limiting charact of modulation : 60–100% of max. deviation

RECEIVER

- Receive system : Double-conversion superheterodyne
- Intermediate frequency : 1st: 31.05 MHz, 2nd 450 kHz
- Sensitivity (at 20 dB SINAD)
 - [Marine] : –2 dBμ EMF (typical)
 - [PMR] : –4 dBμ EMF (typical)
- Squelch sensitivity : –6 dBμ EMF (typical) (at threshold)
- Intermodulation rejection ratio
 - [Marine] : 68 dB
 - [PMR] : 65 dB
- Spurious response rejection ratio : 70 dB
- Adjacent channel selectivity
 - [Marine] : 70 dB
 - [PMR] : 70 dB (Wide), 60 dB (Narrow)
- Audio output power
 - [Marine] : 0.2 W at 10% distortion with an 8 Ω load
 - [PMR] : 0.35 W at 10% distortion with an 8 Ω load
- Hum and noise
 - [Marine] : 40 dB
 - [PMR] : 40 dB (Wide), 34 dB (Narrow)

All stated specifications are subject to change without notice or obligation.

15 OPTIONS

◇ BATTERY CASE AND PACK

- **BP-225** NI-Cd BATTERY PACK
7.2 V/1100 mAh Ni-Cd battery pack.
- **BP-224** NI-Cd BATTERY PACK
7.2 V/750 mAh Ni-Cd battery pack.
- **BP-223** BATTERY CASE
Battery case for 6 × AA (LR6) Alkaline cells.

◇ CHARGERS

- **BC-119N** DESKTOP CHARGER + **AD-109** CHARGER ADAPTER
+ **BC-145E** AC ADAPTER
For rapid charging of battery packs. An AC adapter is supplied with the charger depending on versions. Charging time: approx. 2.2 to 2.8 hours (BP-225).
- **BC-121N** MULTI-CHARGER + **AD-109** CHARGER ADAPTER (6 pcs.)
+ **BC-124** AC ADAPTER
For rapid charging of up to 6 battery packs (six AD-109's are required) simultaneously. An AC adapter should be purchased separately. Charging time: approx. 2.2 to 2.8 hours (BP-225).
- **BC-158** DESKTOP CHARGER + **BC-147E** AC ADAPTER
Used for regular charging of battery pack. The same as supplied with the transceiver. Charging time: approx. 12 hours (BP-225).

◇ BELT CLIPS

- **MB-103** BELT CLIP
The same as supplied with the transceiver.
- **MB-86** SWIVEL BELT CLIP
Belt clip for swivel type.
- **MB-96F/96N** BELT HANGER
 - ➔ MB-96F: Attaches with the supplied belt clip (Not swivel type).
 - ➔ MB-96N: Belt hanger for swivel type.

◇ DC CABLES

- **CP-17L** CIGARETTE LIGHTER CABLE
Charges the battery pack through a 12 V cigarette lighter socket. (For BC-119N)
- **OPC-515L/OPC-656** DC POWER CABLES
Charges the battery pack using 13.8 V power source instead of the AC adapter.
OPC-515L: For BC-119N
OPC-656 : For BC-121N

◇ OTHER OPTIONS

- **HM-125** SPEAKER-MICROPHONE
Full sized waterproof (IPX7; 1m/30 min.) speaker-microphone. Includes an alligator clip to attach the speaker mic to your shirt, collar, etc.
- **HS-94/HS-95/HS-97** HEADSET + **OPC-1392** HEADSET ADAPTER
HS-94: Ear-piece type
HS-95: Neck-arm type
HS-97: Throat microphone

Different versions of this radio use different options. Ask your authorized dealer for details.

QUICK REFERENCE

16

Important operating instructions are summed up on this and the following page.

By cutting along the line and folding on the dotted line, it will become a card sized operating guide which can easily be carried in a card case or wallet.

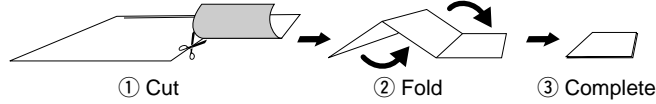

ICOM OPERATION GUIDE IC-M90E

■ IN CASE OF EMERGENCY

○ USING CHANNEL 16

DISTRESS CALL PROCEDURE

1. "MAYDAY MAYDAY MAYDAY."
2. "THIS IS (name of vessel)"
3. Your call sign or other indication of the vessel.
4. "LOCATED AT (your position)"
5. The nature of the distress and assistance required.
6. Any other information which might facilitate the rescue.

←CUT HERE→

■ CHANNEL SELECTION (pgs. 7, 8, 10)

• Channel 16 (p. 7)



• Call channel (p. 7)



• International/USA/ATIS and LAND channels (p. 8)

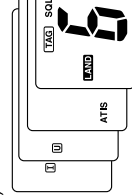

• Call channel programming (p. 10)

- ① Push [16•C] for 1 sec. to select the call channel.
- ② Push [16•C] for 3 sec. (until long beep changes to 2 short beeps)
- ③ Push [▲/▼] to select the desired channel.
- ④ Push [16•C] to program the displayed channel as the call channel.

■ **SET MODE** (pgs. 16–21)

- ① While pushing [SQL • MONI], turn power ON.
- ② Push [SQL•MONI] again to select an item.

Refer to pgs. 16-21 for set mode item.
- ③ Push [▲/▼] to select the desired condition.
- ④ Push [16•C] to return to regular operating mode.

■ **DUALWATCH/TRI-WATCH** (p. 14)

- ① Select dual or tri-watch in the SET mode (p. 18).
- ② Push [▲/▼] to select the desired channel.
- ③ Push [SCAN • DUAL] for 1 sec. to start dualwatch or tri-watch (depending on SET mode).
- ④ To cancel dualwatch/tri-watch, push [SCAN•DUAL] again.

■ **TAG CHANNELS** (p. 13)

- ① Push [▲/▼] to select the desired channel.
- ② Push [▲/▼] for 1 sec. to change the TAG setting ON and OFF.

■ **LOCK FUNCTION** (p. 10)

Push [H/L/0 • 

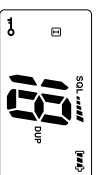

■ **SQUELCH LEVEL** (p. 11)

Push [SQL • MONI], then adjust the squelch level with [▲/▼].

■ **MONITOR FUNCTION** (p. 10)

- ① Select monitor switch action in SET mode (p. 18).
- ② Push [SQL•MONI] for 1sec. to activate the monitor function.



■ **SCAN** (pgs. 12, 13)

Push [SCAN • DUAL] to start/stop scanning.

CE CE Versions of the IC-M90E which display the “CE” symbol on the serial number seal, comply with the essential requirements of the European Radio and Telecommunication Terminal Directive 1999/5/EC.



This warning symbol indicates that this equipment operates in non-harmonised frequency bands and/or may be subject to licensing conditions in the country of use. Be sure to check that you have the correct version of this radio or the correct programming of this radio, to comply with national licensing requirement.

	DECLARATION OF CONFORMITY
<p>We Icom Inc. Japan 1-1-32, Kamiminami, Hirano-ku Osaka 547-0003, Japan</p> <p>Declare on our sole responsibility that this equipment complies the essential requirements of the Radio and Telecommunications Terminal Equipment Directive, 1999/5/EC, and that any applicable Essential Test Suite measurements have been performed.</p> <p>Kind of equipment: <u>VHF MARINE TRANSCEIVER</u></p> <p>Type-designation: <u>IC-M90E</u> PMR: 146-174 MHz 12.5 kHz/ 20 kHz/ 25 kHz</p> <p>Version (where applicable): This compliances is based on conformity with the following harmonised standards, specifications or documents: i) <u>EN 301 178-2 V1.1.1 (2000-8)</u> ii) <u>EN 60945 1997</u> iii) <u>EN 60950 August 1992, A11 1997</u> iv) <u>EN 300 698-2 V1.1.1 (2000-8)</u> v) <u>EN 301 489-1 V1.3.1 (2001-9)</u> vi) <u>EN 301 489-5 (2000-8)</u> vii) <u>EN 300 086-2 (2001-3)</u></p>	<p>CE0560 </p> <p><u>Düsseldorf 29th Oct. 2004</u> Place and date of issue</p> <p>Icom (Europe) GmbH Himmelgeister straÙe 100 D-40225 Düsseldorf</p> <p>Authorized representative name <u>H. Ikegami</u> General Manager</p> <p> Signature</p> <p style="text-align: center;">Icom Inc.</p>

Count on us!

< Intended Country of Use >

- GER FRA ESP SWE
 AUT NED POR DEN
 GBR BEL ITA FIN
 IRL LUX GRE SUI
 NOR